



MORENO VALLEY  
WHERE DREAMS SOAR

# CITY OF MORENO VALLEY STANDARD PLANS

2022 EDITION  
(WITH UPDATES NOVEMBER 2023)



A handwritten signature in black ink, appearing to read "Melissa Walker".

MELISSA WALKER, PE  
*Public Works Director / City Engineer*

City of Moreno Valley  
14177 Frederick Street, P.O. Box 88005, Moreno Valley, CA 92552-0805 - (951) 413-3100

## BY WAY OF EXPLANATION

*The original Edition of the City of Moreno Valley Standard Plans, approved in 1994, marked the culmination of years of efforts by city staff working in cooperation with organizations such as the American Public Works Association (APWA), the Riverside County Flood Control & Water Conservation District, the Southern California Edison Company, the Gas Company, Verizon, and Eastern Municipal Water District as well as private members of the construction industry.*

*Since the original 1994 Edition, subsequent editions have been released over the years to include changes reflecting current industry standards and to maintain minimum acceptable standards for quality design and construction work in the City. The City of Moreno Valley Standard Plans are to be maintained as "living" documents as required by Resolution No. 2008-11 approved by the City Council.*

*These Standard Plans answer the need for uniform design and construction standards and benefit both the general public and private contracting industry by eliminating conflicts and confusion, lowering construction costs, and encouraging more competitive bidding by contractors. These standard plans include designs prepared by various City Departments and standards from other agencies with or without modifications.*

*These standard plans are intended for use on City construction projects and on Private Development projects in the City. Any other standards different than these City of Moreno Valley Standard Plans must have prior approval from the Public Works Director/City Engineer.*

*The standard plans are named with a four digit alpha designation (identifying it as a Moreno Valley city standard plan and identifying the standard plan section), followed by the standard plan number, and ending with a revision number suffix.*

Moreno Valley,  
Street Improvement

Revision  
Number

**MVSI-105A-0**

Standard Plan  
Number

*The standard plans are organized and grouped in sections which correspond to the sections in the APWA's standard plans (e.g. Section 1: Street Improvements, Section 2: Sewers and Sanitation, etc.)*

*This 2022 Edition Standard Plans is effective as of the date signed and approved by the Public Works Director/City Engineer.*



# City of Moreno Valley

## Standard Plans Index - 2022 Edition

---

### **SECTION 1: Street Improvements**

#### General

MVSI-010A-0	<i>Acronyms and Abbreviations</i>
MVSI-010B-0	<i>Drafting Standards and Topo Symbols</i>
MVSI-010C-0	<i>Drafting Standards and Topo Symbols</i>
MVSI-010D-0	<i>Drafting Standards and Topo Symbols</i>

#### Street Sections

MVSI-100A-3	<i>Street Classification and Cross Section Design Standards</i>
MVSI-100B-1	<i>Street Classification and Cross Section Design Standards Notes</i>
MVSI-101A-1	<i>Divided Major Arterial</i>
MVSI-101B-1	<i>Alternate Divided Major Arterial</i>
MVSI-102A-1	<i>Modified Divided Major Arterial</i>
MVSI-102B-1	<i>Alternate Modified Divided Major Arterial</i>
MVSI-103A-1	<i>4-Lane Divided Arterial</i>
MVSI-103B-1	<i>Alternate Divided Arterial</i>
MVSI-103C-1	<i>6-Lane Divided Arterial</i>
MVSI-103D-0	<i>Mixed-Use Boulevard</i>
MVSI-104A-1	<i>Arterial</i>
MVSI-104B-1	<i>Alternate Arterial</i>
MVSI-104C-1	<i>Sunnymead Boulevard (Frederick Street to Graham Street)</i>
MVSI-104D-1	<i>Sunnymead Boulevard (Graham Street to Heacock Street) (Indian Street to Perris Boulevard)</i>
MVSI-104E-1	<i>Sunnymead Boulevard (Heacock Street to Indian Street)</i>
MVSI-105A-2	<i>Minor Arterial</i>
MVSI-105B-1	<i>Alternate Minor Arterial</i>
MVSI-105C-1	<i>Pigeon Pass Road</i>
MVSI-106A-1	<i>Industrial Collector</i>
MVSI-106B-0	<i>Collector</i>
MVSI-106C-0	<i>Neighborhood Collector</i>
MVSI-107A-0	<i>Local Street</i>
MVSI-107B-0	<i>Modified Local Street</i>
MVSI-107C-0	<i>Rural Street</i>
MVSI-107D-0	<i>All Weather Transportation Surface</i>
MVSI-108A-0	<i>Hillside Residential Street</i>
MVSI-108B-0	<i>Hillside Collector Street</i>
MVSI-109A-0	<i>Local and Collector Street Bridge</i>
MVSI-109B-0	<i>Minor Arterial Bridge</i>
MVSI-109C-0	<i>Arterial Bridge</i>
MVSI-110-0	<i>Two-Way Bike Path on Separate Right-of-Way</i>

#### Sidewalks, Driveways, and Ramps

MVSI-111A-0	<i>Residential Driveway Approach (For Right-Of-Way Width behind Curb of 10' or More)</i>
-------------	--

# City of Moreno Valley

## Standard Plans Index - 2022 Edition

---

**SECTION 1:      Street Improvements (Continued)**

MVSI-111B-0	<i>Residential Driveway Approach (For Confined Right-Of-Way)</i>
MVSI-111C-1	<i>Residential Driveway Approach (For Confined Right-Of-Way)</i>
MVSI-112A-0	<i>Commercial Driveway Approach: Type 1</i>
MVSI-112B-0	<i>Commercial Driveway Approach: Type 2</i>
MVSI-112C-0	<i>Commercial Driveway Approach: Type 3</i>
MVSI-112D-0	<i>Commercial Driveway Approach: Type 4</i>
MVSI-113-0	<i>Alley Approach</i>
MVSI-114A-2	<i>Access Ramp: Type 1</i>
MVSI-114B-2	<i>Access Ramp: Type 2</i>
MVSI-114C-2	<i>Detectable Warning Surface Details and Notes</i>
MVSI-114D-0	<i>Access Ramp – Alternate Type 2 (Confined Space)</i>
MVSI-115A-0	<i>Sidewalk</i>
MVSI-115B-0	<i>Curb Separated Sidewalk</i>
MVSI-115C-0	<i>Meandering Sidewalk</i>
MVSI-115D-0	<i>Sidewalk Placement around Obstructions</i>
MVSI-116A-0	<i>News Rack Installation and Placement</i>
MVSI-116B-0	<i>News Rack Installation Notes</i>
MVSI-117A-0	<i>Single Post Mailbox Installation</i>
MVSI-117B-0	<i>Multiple Mailbox Installation for New Sidewalk</i>
MVSI-118A-0	<i>Tree Well: Type 1</i>
MVSI-118B-0	<i>Tree Well: Type 2</i>
MVSI-118C-0	<i>Tree Well: Type 3</i>
MVSI-118D-0	<i>Tree Well: Type 4</i>
MVSI-118E-0	<i>Tree Well Notes</i>
MVSI-119-0	<i>Parkway Improvement Spacing</i>

Curb and Gutter

MVSI-120A-0	<i>Type 6 Integral Curb and Gutter</i>
MVSI-120B-0	<i>Type 8 Integral Curb and Gutter</i>
MVSI-121A-0	<i>Type 6A Curb</i>
MVSI-121B-0	<i>Type 8A Curb</i>
MVSI-122-0	<i>Type D-1 Curb</i>
MVSI-123-0	<i>Type C Rolled Curb</i>
MVSI-124-0	<i>Asphalt Concrete Curb</i>
MVSI-125-0	<i>Curb Transition</i>
MVSI-126-0	<i>Curb Address Painting</i>
MVSI-127-1	<i>Cross Gutter and Spandrel</i>

Pavement

MVSI-130-0	<i>Pavement Edge Taper</i>
MVSI-131-0	<i>Join Existing Pavement Detail</i>
MVSI-132A-2	<i>Perpendicular Trench Backfill and Roadway Repair</i>

# City of Moreno Valley

## Standard Plans Index - 2022 Edition

---

### **SECTION 1: Street Improvements (Continued)**

<i>MVSI-132B-3</i>	<i>Parallel Trench Backfill and Roadway Repair</i>
<i>MVSI-132C-3</i>	<i>Trench Backfill and Roadway Repair Notes</i>
<i>MVSI-132D-1</i>	<i>Utility Pothole or Pavement Core Repair</i>
<i>MVSI-132E-2</i>	<i>Water Line (Up to 12" Dia) Trench Backfill and Roadway Repair</i>
<i>MVSI-132F-2</i>	<i>Water Line (Larger than 12" Dia) Trench Backfill and Roadway</i>
<i>MVSI-132G-0</i>	<i>Repair Micro-Trenching and Join Existing Pavement Detail</i>
<i>MVSI-133-0</i>	<i>Recessed Trench Plate Detail</i>
<i>MVSI-134A-0</i>	<i>Speed Hump Detail and Placement</i>
<i>MVSI-134B-0</i>	<i>Speed Hump Installation Notes</i>
<i>MVSI-135-0</i>	<i>Speed Table</i>
<i>MVSI-136A-0</i>	<i>Speed Cushion Detail 36</i>
<i>MVSI-136B-0</i>	<i>Speed Cushion Detail 40</i>
<i>MVSI-136C-0</i>	<i>Speed Cushion Detail 44</i>
<i>MVSI-136D-0</i>	<i>Speed Cushion Notes</i>

#### Median

<i>MVSI-140-0</i>	<i>Emergency Vehicle Median Access</i>
<i>MVSI-141A-0</i>	<i>Median Landscape Meandering Design</i>
<i>MVSI-141B-0</i>	<i>Median Landscape Meandering Design Notes</i>
<i>MVSI-142A-1</i>	<i>Median Hardscape Meandering Design</i>
<i>MVSI-142B-1</i>	<i>Median Hardscape Meandering Design Notes</i>
<i>MVSI-143-0</i>	<i>Median Taper</i>
<i>MVSI-144-0</i>	<i>Median Flare</i>
<i>MVSI-145-0</i>	<i>Restricted Left Turn Median Opening</i>
<i>MVSI-146-0</i>	<i>Aligned Opposite Driveways Restricted Left Turn Median</i>
<i>MVSI-147A-0</i>	<i>Manhole / Curb Conflict with Median Access</i>
<i>MVSI-147B-0</i>	<i>Manhole / Curb Conflict with Median Access</i>

#### Parkway and Residential Yard Drain

<i>MVSI-150A-0</i>	<i>Parkway Culvert</i>
<i>MVSI-150B-0</i>	<i>Parkway Culvert Details and Notes</i>
<i>MVSI-151A-0</i>	<i>Sidewalk Outlet Structure</i>
<i>MVSI-151B-0</i>	<i>Sidewalk Outlet Structure Notes</i>
<i>MVSI-152-1</i>	<i>Curb Drain: Residential</i>
<i>MVSI-153A-1</i>	<i>Typical Lot Drainage and Residential Yard Drain</i>
<i>MVSI-153B-0</i>	<i>Residential Yard Drain – B1 Typical Area Drain</i>
<i>MVSI-153C-0</i>	<i>Residential Yard Drain – B2 Typical Drain Downspout Inlet Detail</i>

#### Design and Construction Policies and Guidelines

<i>MVSI-160A-1</i>	<i>Design Policy</i>
<i>MVSI-160B-1</i>	<i>Design Policy</i>
<i>MVSI-160C-1</i>	<i>Roadway Design Requirements</i>
<i>MVSI-161-0</i>	<i>Bus Turnout</i>
<i>MVSI-162-0</i>	<i>Knuckle</i>
<i>MVSI-163A-0</i>	<i>Cul-de-Sac (Symmetrical)</i>
<i>MVSI-163B-0</i>	<i>Cul-de-Sac (Offset)</i>

# City of Moreno Valley

## Standard Plans Index - 2022 Edition

---

### **SECTION 1:      Street Improvements (Continued)**

<i>MVSI-164A-0</i>	<i>Intersection Sight Distance</i>
<i>MVSI-164B-0</i>	<i>Intersection Sight Distance</i>
<i>MVSI-164C-0</i>	<i>Intersection Sight Distance</i>
<i>MVSI-165-0</i>	<i>Property Line: Corner Cut-Back, Curb Return Radius</i>
<i>MVSI-166A-1</i>	<i>Standard General Notes (For Land Development Division)</i>
<i>MVSI-166B-2</i>	<i>Standard Street Improvement Notes (For Land Development Division)</i>
<i>MVSI-166C-2</i>	<i>Standard Grading Notes (For Land Development Division)</i>
<i>MVSI-166D-2</i>	<i>Standard Precise Grading Notes (For Land Development Division)</i>
<i>MVSI-167A-0</i>	<i>General Street Improvements Notes (For City Capital Improvement Projects)</i>
<i>MVSI-167B-0</i>	<i>General Street Improvements Notes (For City Capital Improvement Projects)</i>
<i>MVSI-168A-1</i>	<i>Standard Title Sheet (For Land Development Division)</i>
<i>MVSI-168B-1</i>	<i>Standard Title Sheet (For City Capital Improvement Projects)</i>

#### Monument

<i>MVSI-170A-1</i>	<i>Monument Cover</i>
<i>MVSI-170B-0</i>	<i>Survey Monument</i>
<i>MVSI-170C-0</i>	<i>Tie-out Standards</i>
<i>MVSI-170D-0</i>	<i>Street Centerline Monument</i>
<i>MVSI-170E-0</i>	<i>Monument Notes</i>

#### Utilities

<i>MVSI-180A-1</i>	<i>Normal Location of Underground Utilities</i>
<i>MVSI-180B-1</i>	<i>Location of Cable TV Ducts at Street Intersections</i>
<i>MVSI-181A-1</i>	<i>Communications Conduit in Parkway Separate Trench Detail</i>
<i>MVSI-181B-1</i>	<i>Communications Conduit in Sidewalk Separate Trench Detail</i>
<i>MVSI-181C-1</i>	<i>Communications Conduit in Pavement Separate Trench Detail</i>
<i>MVSI-181D-1</i>	<i>Typical Multi-Conduit Joint Trench Detail</i>
<i>MVSI-182-1</i>	<i>Telecommunications Trunk Conduit System and Pull Box Layout Detail</i>
<i>MVSI-183-1</i>	<i>Telecommunications Distribution and Service Lateral Conduit System</i>
<i>MVSI-184A-1</i>	<i>Telecommunications Residential Units</i>
<i>MVSI-184B-1</i>	<i>Telecommunications Residential Units</i>
<i>MVSI-185A-1</i>	<i>Telecommunication Technical Provisions</i>
<i>MVSI-185B-1</i>	<i>Telecommunication Technical Provisions</i>
<i>MVSI-185C-1</i>	<i>Telecommunication Technical Provisions</i>
<i>MVSI-185D-1</i>	<i>Telecommunication Technical Provisions</i>
<i>MVSI-186-1</i>	<i>Citywide Communication Conduits</i>



# City of Moreno Valley

## Standard Plans Index - 2022 Edition

---

### **SECTION 2: Sewers and Sanitation**

**Note:** *All Eastern Municipal Water District Standards are adopted in this Section.*

### **SECTION 3: Flood and Erosion Control**

#### General

MVFE-300A-0	Catch Basin
MVFE-300B-0	Catch Basin Notes
MVFE-300C-0	Catch Basin Opening Detail
MVFE-300D-0	Catch Basin Face Plate and Protection Bar Detail
MVFE-300E-0	Catch Basin Manhole Frame and Cover
MVFE-300F-0	Catch Basin Reinforcement

#### Manholes and Structures

MVFE-320A-0	Manhole
MVFE-320B-0	Manhole Notes
MVFE-320C-0	Manhole Shaft for Cast Pipe
MVFE-321A-0	Manhole Frame and Cover
MVFE-321B-0	Manhole Frame and Cover Notes
MVFE-340-0	Concrete Collar for Pipe 24 through 36 Inches

#### Water Quality and Erosion Control

MVFE-350-0	NPDES Notes
MVFE-351A-0	Erosion Control Notes (Rough Grading Phase)
MVFE-351B-0	Erosion Control Notes (Precise Grading Phase)
MVFE-351C-0	Erosion Control Notes (Straw-Bale Barriers)
MVFE-351D-0	Erosion Control Notes
MVFE-351E-0	Construction Driveway Desilting Basin
MVFE-351F-0	Temporary Access Ramp and Check Dam Detail
MVFE-352-0	Semi-Pervious Straw Bale Sediment Barrier
MVFE-353-0	Temporary Desilting Measures at Catch Basin
MVFE-354-0	Stabilized Construction Exit Sediment Removal
MVFE-355-0	Silt Fence Detail
MVFE-356-0	Desilting Basin

**Note:** *All other Riverside County Flood Control and Water Conservation District Standards which are not specifically included are adopted in this Section. The use of APWA's Flood Control and Storm Drain Facilities Standards must have prior approval from the Public Works Director/City Engineer.*

# City of Moreno Valley

## Standard Plans Index - 2022 Edition

---

### **SECTION 4: Street Light and Traffic**

#### Street Light

MVLT-400A-3	<i>Residential and Collector Lighting</i>
MVLT-400B-2	<i>Arterial Highway Lighting (Wireless Equipment Capable)</i>
MVLT-400C-0	<i>Arterial Highway Lighting</i>

#### Traffic

MVLT-410A-0	<i>Street Name Sign</i>
MVLT-410B-0	<i>Street Name Sign Abbreviations</i>
MVLT-410C-1	<i>Street Name Sign Specifications</i>
MVLT-410D-0	<i>Street Name Sign Placement</i>
MVLT-410E-0	<i>Street Name Sign Location</i>
MVLT-411A-0	<i>Internally Illuminated Street Name Sign</i>
MVLT-411B-1	<i>Internally Illuminated Street Name Sign Specifications</i>
MVLT-411C-1	<i>Internally / Retrofit Illuminated Street Name Sign Specifications</i>
MVLT-411D-0	<i>Mounting Assembly – Illuminated Street Name Sign Specifications</i>
MVLT-411E-0	<i>Structural Support for Various Luminaires on Type 1-A Pole</i>
MVLT-412-0	<i>Stop Sign Installation</i>
MVLT-413-0	<i>Marbelite Sign Installation</i>
MVLT-414A-0	<i>Sign Post Installation</i>
MVLT-414B-1	<i>Sign Post Installation Notes</i>
MVLT-414C-0	<i>Sign Post Block Out</i>
MVLT-415A-0	<i>Project Sign (Road Work)</i>
MVLT-415B-0	<i>Project Sign (Other Agencies)</i>
MVLT-415C-0	<i>Project Sign (Project Completion)</i>
MVLT-416A-0	<i>End of Road Treatment</i>
MVLT-416B-0	<i>End of Road Treatment Details</i>
MVLT-417-0	<i>Object Markers</i>
MVLT-418A-0	<i>Delineators</i>
MVLT-418B-0	<i>Delineator Placement</i>
MVLT-419-0	<i>Median Nose Treatment</i>
MVLT-420-0	<i>Street Pole Banner</i>
MVLT-430A-1	<i>Street Striping &amp; Pavement Legend Standards &amp; Specifications</i>
MVLT-430B-0	<i>Street Striping &amp; Pavement Legend Standards &amp; Specifications</i>
MVLT-430C-0	<i>Street Striping &amp; Pavement Legend Standards &amp; Specifications</i>
MVLT-431-1	<i>Stop Bar Legend Placement</i>
MVLT-432-1	<i>Crosswalk Location</i>
MVLT-433-0	<i>Continental Crosswalk and Advance Limit Line Placement</i>
MVLT-440A-0	<i>“Blue Dot” Type 1 Marker Placement Notes</i>
MVLT-440B-0	<i>“Blue Dot” Type 1 Marker Placement Street Intersection &amp; Cul-de-Sac</i>
MVLT-440C-0	<i>“Blue Dot” Type 1 Marker Placement - Divided Street &amp; Street with Turn Lane</i>
MVLT-450A-0	<i>Traffic Induction Loops (Decorative Crosswalk)</i>
MVLT-450B-0	<i>Traffic Induction Loops (Thermoplastic Crosswalk)</i>

# City of Moreno Valley

## Standard Plans Index - 2022 Edition

---

### **SECTION 4: Street Light and Traffic (Continued)**

MVLТ-450C-0	<i>Traffic Induction Loops Wiring Details</i>
MVLТ-460-0	<i>Type 333 Controller Cabinet Foundation Detail</i>
MVLТ-461-0	<i>Dual Meter Traffic Signal Service Foundation</i>

**Note:** *Various State's Standards for Street Light and Traffic may be used subject to review and approval from the Public Works Director/City Engineer.*

### **SECTION 5: Landscaping and Irrigation Systems**

#### Landscaping

MVLІ-500A-0	<i>Palm Tree Planting (Special Districts)</i>
MVLІ-500B-1	<i>Palm Tree Planting (Parks &amp; CS)</i>
MVLІ-501A-0	<i>Container Planting (Special Districts)</i>
MVLІ-501B-1	<i>Container Planting (Shrub Beds) (Parks &amp; CS)</i>
MVLІ-501C-0	<i>Container Planting on Slope (Special Districts)</i>
MVLІ-501D-1	<i>Container Planting on Slope (Parks &amp; CS)</i>
MVLІ-502-1	<i>Native Shrub Planting/On Slope Shrub Planting (Parks &amp; CS)</i>
MVLІ-503A-0	<i>Vine Detail: Non-Adhering Type (Special Districts)</i>
MVLІ-503B-0	<i>Vine Detail: Adhering Type (Parks &amp; CS)</i>
MVLІ-504-0	<i>Tree Spacing Requirements (Special Districts)</i>
MVLІ-505A-0	<i>Shrub/Groundcover Spacing (Special Districts)</i>
MVLІ-505B-0	<i>Shrub/Groundcover Spacing (Parks &amp; CS)</i>
MVLІ-510A-0	<i>Tree Guying Detail - 36" Box or Larger (Special Districts)</i>
MVLІ-510B-1	<i>Tree Guying Detail - 36" Box or Larger (Parks &amp; CS)</i>
MVLІ-511A-0	<i>Typical Double Stake Tree (15 Gal. - 24" Box) (Special Districts)</i>
MVLІ-511B-1	<i>Typical Double Stake Tree (Parks &amp; CS)</i>
MVLІ-511C-1	<i>Steel Double Stake Tree (Parks &amp; CS)</i>
MVLІ-511D-0	<i>Double Stake Tree on Slope (Special Districts)</i>
MVLІ-511E-1	<i>Double Stake Tree on Slope (Parks &amp; CS)</i>
MVLІ-512A-0	<i>Triple Stake Tree (Special Districts)</i>
MVLІ-512B-1	<i>Triple Stake Tree (Parks &amp; CS)</i>
MVLІ-512C-0	<i>Triple Stake Tree on Slope (Special Districts)</i>
MVLІ-512D-1	<i>Triple Stake Tree on Slope (Parks &amp; CS)</i>
MVLІ-520A-0	<i>Mulch Installation (Special Districts)</i>
MVLІ-520B-0	<i>Bark Installation (Parks &amp; CS)</i>
MVLІ-521-0	<i>2" x 4" Redwood Header (Special Districts)</i>
MVLІ-522A-0	<i>6" Wide Concrete Mow Curb (Special Districts)</i>
MVLІ-522B-0	<i>6" Wide Concrete Mow Curb (Parks &amp; CS)</i>
MVLІ-522C-0	<i>12" Wide Concrete Mow Curb (Parks &amp; CS)</i>
MVLІ-523A-0	<i>Erosion Control Netting (Landscaping) (Special Districts)</i>
MVLІ-523B-0	<i>Erosion Control Netting (Landscaping) (Parks &amp; CS)</i>
MVLІ-524A-0	<i>Linear Root Barrier (Special Districts)</i>
MVLІ-524B-0	<i>Linear Root Barrier (Parks &amp; CS)</i>

# City of Moreno Valley

## Standard Plans Index - 2022 Edition

---

### **SECTION 5:      Landscaping and Irrigation Systems (Continued)**

#### Irrigation

MVLI-530-0	CCU Radio Link Antenna & Enclosure Detail (Special Districts)
MVLI-531A-0	Controller / Satellite Enclosure Detail (Special Districts)
MVLI-531B-0	Smart Controller Enclosure Detail (Parks & CS)
MVLI-532-0	CCU Enclosure Detail (Special Districts)
MVLI-533-0	External Ground Rod Assembly Detail (Special Districts)
MVLI-534-0	LEIT XRC Irrigation Controller (Parks & CS)
MVLI-535-0	Multiple Controllers Using One ET Gage (Parks & CS)
MVLI-536-0	Typical Transient Protection Installation (Parks & CS)
MVLI-537-0	Vandal Resistant ET Gage Enclosure (Parks & CS)
MVLI-538-0	Irrigation Controller Grounding Instruction (Parks & CS)
MVLI-539-0	Irrigation Controller Enclosure Installation Detail (Parks & CS)
MVLI-540A-0	Flow Sensor Assembly Detail (Special Districts)
MVLI-540B-0	Flow Sensor Assembly Detail (Parks & CS)
MVLI-540C-0	FMBX Flow Meter Installation (Parks & CS)
MVLI-541-0	Rain Gauge / Weather Sensor Installation Detail (Parks & CS)
MVLI-542A-0	Telemetry Pull-Box Assembly Detail (Special Districts)
MVLI-542B-0	Telemetry Pull-Box Assembly Detail (Parks & CS)
MVLI-543A-0	Master Valve Assembly Detail (Special Districts)
MVLI-543B-0	Master Valve Assembly Detail (Parks & CS)
MVLI-543C-0	Master Valve and Flow Meter Installation (Parks & CS)
MVLI-544A-0	Toe Nipple Assembly (Special Districts)
MVLI-544B-0	Toe Nipple Assembly (Parks & CS)
MVLI-545A-0	Irrigation Wire Connector (Special Districts)
MVLI-545B-0	Irrigation Wire Connector (Parks & CS)
MVLI-545C-0	Irrigation Control Wire Notes (Parks & CS)
MVLI-546-0	Irrigation Booster Pump Detail (Special Districts)
MVLI-547A-0	Reduced Pressure Backflow Preventer (Special Districts)
MVLI-547B-1	Backflow Preventer (Parks and CS)
MVLI-548A-0	Backflow Preventer Enclosure (Special Districts)
MVLI-548B-0	Single Backflow Cover (Parks and CS)
MVLI-548C-0	Double Backflow Cover (Parks and CS)
MVLI-550A-0	Pressure Reducing Valve (Special Districts)
MVLI-550B-0	Pressure Reducing Valve (Parks & CS)
MVLI-551A-0	Ball Valve/Gate Valve - 3" Or Smaller (Special Districts)
MVLI-551B-0	Ball Valve/Gate Valve - 3" Or Smaller (Parks & CS)
MVLI-552A-0	Remote Control Valve with Union (Special Districts)
MVLI-552B-0	Remote Control Valve Detail (Parks and CS)
MVLI-553A-0	Remote Control Valve for Drip Systems (Special Districts)
MVLI-553B-0	Remote Control Valve Detail for Drip Systems (Parks & CS)
MVLI-554A-0	Quick Coupling Valve (Special Districts)
MVLI-554B-0	Quick Coupling Ball Valve (Parks & CS)
MVLI-555A-0	Air Vacuum Relief Valve (Special Districts)
MVLI-555B-0	Air Vacuum Relief Valve (Parks & CS)



# City of Moreno Valley

## Standard Plans Index - 2022 Edition

---

**SECTION 5:      Landscaping and Irrigation Systems (Continued)**

MVLI-556A-0	<i>Irrigation Stub-Out Box (Special Districts)</i>
MVLI-556B-0	<i>Irrigation Stub-Out Box (Parks &amp; CS)</i>
MVLI-560A-0	<i>Landscape Trench Detail (Special Districts)</i>
MVLI-560B-0	<i>Trench Detail (Parks &amp; CS)</i>
MVLI-561A-0	<i>Sleeving Detail (Special Districts)</i>
MVLI-561B-0	<i>Sleeving Detail (Parks &amp; CS)</i>
MVLI-562-0	<i>Median and Parkway Irrigation Line Installation (Special Districts)</i>
MVLI-563A-0	<i>Deep Well Tree Irrigation (Special Districts)</i>
MVLI-563B-0	<i>Deep Well Tree Irrigation (Parks &amp; CS)</i>
MVLI-564-0	<i>Drip Emitter Installation (Special Districts)</i>
MVLI-565-0	<i>Tree Well Sump (Parks &amp; CS)</i>
MVLI-566-0	<i>Rainbird RWS-BCG02 Root Watering System (Parks &amp; CS)</i>
MVLI-570A-0	<i>6" Pop-up Spray Head (Special Districts)</i>
MVLI-570B-0	<i>12" Pop-up Spray Head (Special Districts)</i>
MVLI-570C-0	<i>6" or 12" Pop-up Spray Head (Parks &amp; CS)</i>
MVLI-571A-0	<i>Pop-up Rotary Head (Special Districts)</i>
MVLI-571B-0	<i>Pop-up Rotary Head (Parks &amp; CS)</i>
MVLI-572-0	<i>Rotor Installation on Fixed Riser (Special Districts)</i>
MVLI-573-0	<i>Rainbird 1800 Sam PRS Pop Up Spray Head (Parks &amp; CS)</i>
MVLI-574A-0	<i>Dripperline (With Integrated Check Valves) Center Feed Layout (Special Districts)</i>
MVLI-574B-0	<i>Dripperline (With Integrated Check Valves) Center Feed Layout (Parks &amp; CS)</i>
MVLI-574C-0	<i>Dripperline (Recycled Water Systems) Center Feed Layout (Special Districts)</i>
MVLI-574D-0	<i>Dripperline (Recycled Water Systems) Center Feed Layout (Parks &amp; CS)</i>
MVLI-574E-0	<i>PVC Pipe with Swing-Joint Connection to Dripperline (Special Districts)</i>
MVLI-574F-0	<i>PVC Pipe with Swing-Joint Connection to Dripperline (Parks &amp; CS)</i>
MVLI-574G-0	<i>Manual Shut-Off / Flush Valve (For Dripperline) (Special Districts)</i>
MVLI-574H-1	<i>Manual Shut-Off / Flush Valve (For Dripperline) (Parks &amp; CS)</i>
MVLI-574I-0	<i>Automatic Flush Valve (For Dripperline) (Special Districts)</i>
MVLI-574J-0	<i>Automatic Flush Valve (For Dripperline) (Parks &amp; CS)</i>
MVLI-574K-0	<i>Air / Vacuum Relief Valve (For Dripperline) (Special Districts)</i>
MVLI-574L-1	<i>Air / Vacuum Relief Valve (For Dripperline) (Parks &amp; CS)</i>
MVLI-580A-0	<i>Thrust Blocks (Special Districts)</i>
MVLI-580B-0	<i>Thrust Blocks (Parks &amp; CS)</i>
MVLI-581-0	<i>Box Identification (Parks &amp; CS)</i>
MVLI-582-0	<i>Christy Tag (Parks &amp; CS)</i>

# City of Moreno Valley

## Standard Plans Index - 2022 Edition

---

### **SECTION 6:      General Facilities**

#### Parks Facilities

MVGF-600-0	<i>Parks and Community Services - General Notes</i>
MVGF-610A-1	<i>Multi-Use Trail</i>
MVGF-610B-0	<i>Multi-Use Trail</i>
MVGF-610C-0	<i>Multi-Use Trail</i>
MVGF-610D-0	<i>Multi-Use Trail</i>
MVGF-610E-0	<i>Multi-Use Feeder Trail</i>
MVGF-610F-0	<i>Multi-Use Trail</i>
MVGF-610G-0	<i>Multi-Use Trail</i>
MVGF-610H-0	<i>Multi-Use Trail</i>
MVGF-610I-1	<i>Multi-Use Trail</i>
MVGF-610J-0	<i>Multi-Use Trail</i>
MVGF-610K-0	<i>Multi-Use Trail</i>
MVGF-610L-0	<i>Riding and Hiking Trails</i>
MVGF-610M-0	<i>Multi-Use Trail Specifications</i>
MVGF-610N-1	<i>Multi-Use Trail Specifications</i>
MVGF-611-0	<i>Concrete Walk / Slab / Approach Adjacent To Trail</i>
MVGF-612-0	<i>Secondary Riding and Hiking</i>
MVGF-613A-0	<i>Trailhead Ingress / Egress Gate Detail</i>
MVGF-613B-0	<i>Single Trail Access Gate</i>
MVGF-613C-0	<i>Double Trail Access Gate</i>
MVGF-613D-0	<i>Double Trail Access Gate with Center Opening</i>
MVGF-613E-0	<i>EZ 55 Bracket with Post</i>
MVGF-614A-0	<i>24" x 24" Catch Basin</i>
MVGF-614B-0	<i>Typical Area Drain</i>
MVGF-615A-0	<i>Drinking Fountain Sump Drainage Detail</i>
MVGF-615B-0	<i>Drinking Fountain and Bottle Filler</i>
MVGF-616-0	<i>Cable Railing</i>
MVGF-617-0	<i>Hitching Rail</i>
MVGF-618A-0	<i>Electrical Pull Box for Parks</i>
MVGF-618B-0	<i>Trench Details for Conduit Installations in Parks</i>
MVGF-619-0	<i>Retaining Walls for Pad-Mounted Meter Enclosures</i>
MVGF-620A-0	<i>Graphic Plan, Two Sided Sign (96" L x 60" HT)</i>
MVGF-620B-0	<i>Construction Plan, Two Sided Sign (90" L x 60" HT)</i>
MVGF-620C-0	<i>Construction Plan, Sign Base (12" W x 102" L)</i>
MVGF-620D-0	<i>Installation Plan, Two Sided Sign (96" L x 60" HT)</i>
MVGF-621A-0	<i>Graphic Plan, One Sided Sign (96" L x 60" HT)</i>
MVGF-621B-0	<i>Construction Plan, One Sided Sign (96" L x 60" HT)</i>
MVGF-621C-0	<i>Construction Plan, Sign Base (12" W x 102" L)</i>
MVGF-621D-0	<i>Installation Plan, One Sided Sign (96" L x 60" HT)</i>
MVGF-622-0	<i>Horse Watering Station</i>
MVGF-623A-1	<i>Parking Lots</i>
MVGF-623B-0	<i>Join Existing Parking Lot Pavement Detail</i>

# City of Moreno Valley

## Standard Plans Index - 2022 Edition

---

**SECTION 6:      **General Facilities (Continued)****

<i>MVGF-623C-1</i>	<i>Concrete Pavement Joint</i>
<i>MVGF-623D-0</i>	<i>Parks Striping and Pavement Legend Standards &amp; Specifications</i>
<i>MVGF-623E-0</i>	<i>Type 6 Integral Curb and Gutter for Parks</i>
<i>MVGF-623F-0</i>	<i>Type 8A Curb for Parks</i>
<i>MVGF-623G-0</i>	<i>Type C Rolled Curb for Parks</i>
<i>MVGF-623H-0</i>	<i>Curb Separated Walkway for Parks</i>
<i>MVGF-623I-0</i>	<i>Walk Way Placement around Obstructions for Parks</i>
<i>MVGF-623J-0</i>	<i>Tree Well for Parks</i>
<i>MVGF-623K-0</i>	<i>Commercial Driveway Approach for Parks</i>
<i>MVGF-624A-0</i>	<i>Parks Facility Dedication Plaque</i>
<i>MVGF-624B-0</i>	<i>Parks Dedication Plaque Pedestal</i>
<i>MVGF-625A-0</i>	<i>Sign Post Installation in Parks</i>
<i>NVGF-625B-0</i>	<i>Parks Sign Post Installation Notes</i>
<i>MVGF-626-0</i>	<i>Concrete Light Pole Base</i>
<i>MVGF-627A-0</i>	<i>Pole Base Fixture Footing For Parks</i>
<i>MVGF-627B-0</i>	<i>Light Pole With Above Grade Pole Base</i>

Fences and Gates

<i>MVGF-640-0</i>	<i>3-Rail PVC Fence</i>
<i>MVGF-641-0</i>	<i>Park Projects Chain Link Fence and Gates</i>
<i>MVGF-642-0</i>	<i>Fire Access Gate</i>
<i>MVGF-643A-0</i>	<i>Steel Fence &amp; Gate</i>
<i>MVGF-643B-0</i>	<i>Steel Fence &amp; Gate for Cell Sites</i>
<i>MVGF-644-0</i>	<i>Modified Extended Detention Basin Fence &amp; Gate Detail Guide</i>

Retaining Wall

<i>MVGF-650A-0</i>	<i>Retaining Wall Notes for Electrical Facilities</i>
<i>MVGF-650B-0</i>	<i>Retaining Wall Sections for Electrical Facilities</i>

Waste Enclosure

<i>MVGF-660A-1</i>	<i>Dual Bin Covered Waste Enclosure For Parks Case A</i>
<i>MVGF-660B-1</i>	<i>Dual Bin Covered Waste Enclosure For Parks Case B</i>
<i>MVGF-660C-1</i>	<i>Dual Bin Covered Waste Enclosure For Parks Notes</i>
<i>MVGF-660D-1</i>	<i>Waste Enclosure Gate for Parks</i>
<i>MVGF-660E-1</i>	<i>Waste Enclosure Wall and Footing for Parks</i>
<i>MVGF-660F-1</i>	<i>Waste Enclosure Gate Hinge for Parks</i>

# City of Moreno Valley

## Standard Plans Index - 2022 Edition

---

### **SECTION 6:      General Facilities (Continued)**

#### Building Facilities

<i>MVGF-670A-0</i>	<i>Facility Dedication Plaque</i>
<i>MVGF-670B-0</i>	<i>Dedication Plaque Pedestal</i>

### **SECTION 7:      Electric Utility**

<i>MVEU-700-0</i>	<i>Title Sheet Base (for Electric Utility Division)</i>
<i>MVEU-701-0</i>	<i>Conduits &amp; Cable Call-Outs</i>
<i>MVEU-702-0</i>	<i>Structure &amp; Equipment Symbols</i>
<i>MVEU-703-1</i>	<i>Equipment Legends</i>
<i>MVEU-704-0</i>	<i>Vicinity &amp; Project Map</i>
<i>MVEU-705-0</i>	<i>Approved Status Stamp</i>
<i>MVEU-706A-0</i>	<i>Designer Declaration</i>
<i>MVEU-706B-0</i>	<i>Engineer's Notice to Contractor</i>
<i>MVEU-707A-0</i>	<i>Statement of Plan Review</i>
<i>MVEU-707B-0</i>	<i>Statement of Plan Review</i>
<i>MVEU-708-0</i>	<i>Design Information</i>
<i>MVEU-709-1</i>	<i>Dry Utilities Trench Section</i>
<i>MVEU-710A-0</i>	<i>Electrical Singleline Diagram Residential</i>
<i>MVEU-710B-0</i>	<i>Electrical Singleline Diagram Backbone</i>
<i>MVEU-711A-0</i>	<i>48" x 54" Pad for Pad Mounted &amp; Mini Pad Mounted Transformer</i>
<i>MVEU-711B-0</i>	<i>Mini Pad Mounted Transformer Cable Connections</i>
<i>MVEU-712-1</i>	<i>66" x 72" Pad for 75kVA - 300kVA Pad Mounted Transformers</i>
<i>MVEU-713-0</i>	<i>72" x 94" Pad for 75kVA - 500kVA Pad Mounted Transformers</i>
<i>MVEU-714-0</i>	<i>6' x 8'-6" Pad with Box for 75kVA-500kVA Pad Mounted Transformers</i>
<i>MVEU-715-0</i>	<i>8' x 10' Pad with Box for 750kVA-1000kVA Pad Mounted Transformers</i>
<i>MVEU-716-0</i>	<i>10' x 12' Pad with Box for 1500kVA - 2500kVA Pad Mounted Transformers</i>
<i>MVEU-717-0</i>	<i>72" x 94" Pad for Pad-Mounted Capacitors</i>
<i>MVEU-718-0</i>	<i>Pad Mounted Switch Enclosure Detail 5' x 10'-6" x 7'</i>
<i>MVEU-719-0</i>	<i>17" x 30" x 24" Pull Box for Service Connection</i>
<i>MVEU-720-0</i>	<i>10.5" x 17" x 24" Pull Box for Street Light Connection</i>
<i>MVEU-721-0</i>	<i>Precast Concrete Parkway Enclosure 2' x 3' x 5' and 3' x 5' x 5'</i>
<i>MVEU-722-0</i>	<i>Protective Barriers for Equipment and Structures Subject to Traffic Locations</i>
<i>MVEU-723-0</i>	<i>Retaining Walls for Pad-Mounted Switches and Transformers</i>
<i>MVEU-724A-2</i>	<i>Joint Trench Details for Conduit Installations</i>
<i>MVEU-724B-2</i>	<i>Electric Only Trench Details for Conduit Installations</i>
<i>MVEU-725-0</i>	<i>Surface Operable Enclosure 5' x 8.5' x 5'</i>
<i>MVEU-726-0</i>	<i>Vault 6' x 12' x 7'</i>
<i>MVEU-727A-0</i>	<i>Conduit Bank Requirements - Installation in a Bore</i>



# City of Moreno Valley

## Standard Plans Index - 2022 Edition

---

### **SECTION 7: Electric Utility (Continued)**

<i>MVEU-727B-0</i>	<i>Conduit Bank Requirements</i>
<i>MVEU-728A-0</i>	<i>Manhole 5' x 10.5' x 7'</i>
<i>MVEU-728B-0</i>	<i>Manhole 4' x 6.5' x 7'</i>
<i>MVEU-729A-0</i>	<i>Project Sign- Electrical Distribution Project</i>
<i>MVEU-729B-0</i>	<i>Project Completion Sign- Electrical Distribution Project</i>
<i>MVEU-730A-0</i>	<i>Vault 7' x 14' x 8'</i>
<i>MVEU-730B-0</i>	<i>Vault 7' x 18' x 8'</i>
<i>MVEU-730C-0</i>	<i>4' x 6' Pad w/ 2.5' x 4' Box for PMH-4 or PMH-5 Switchgear</i>
<i>MVEU-731-0</i>	<i>Support for Conduits on Bridges</i>
<i>MVEU-732A-0</i>	<i>Alternate Supports for Conduits on Bridges</i>
<i>MVEU-732B-0</i>	<i>Alternate Supports for Conduits on Bridges</i>
<i>MVEU-733-0</i>	<i>Expansion Joint for Plastic Conduit</i>

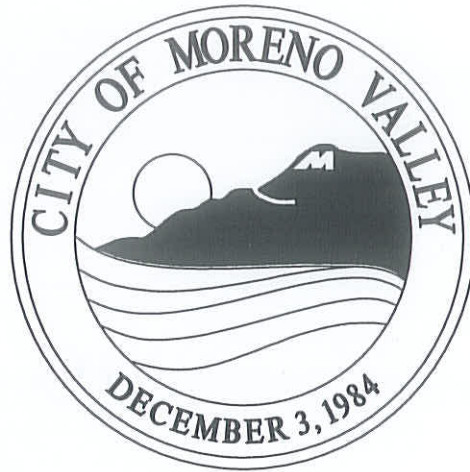

# **CITY OF MORENO VALLEY STANDARD PLANS**

## **SECTION 1**

### **STREET IMPROVEMENTS**

# City of Moreno Valley

## Standard Plans Index - 2022 Edition

---

### **SECTION 1: Street Improvements**

#### General

MVSI-010A-0	<i>Acronyms and Abbreviations</i>
MVSI-010B-0	<i>Drafting Standards and Topo Symbols</i>
MVSI-010C-0	<i>Drafting Standards and Topo Symbols</i>
MVSI-010D-0	<i>Drafting Standards and Topo Symbols</i>

#### Street Sections

MVSI-100A-3	<i>Street Classification and Cross Section Design Standards</i>
MVSI-100B-1	<i>Street Classification and Cross Section Design Standards Notes</i>
MVSI-101A-1	<i>Divided Major Arterial</i>
MVSI-101B-1	<i>Alternate Divided Major Arterial</i>
MVSI-102A-1	<i>Modified Divided Major Arterial</i>
MVSI-102B-1	<i>Alternate Modified Divided Major Arterial</i>
MVSI-103A-1	<i>4-Lane Divided Arterial</i>
MVSI-103B-1	<i>Alternate Divided Arterial</i>
MVSI-103C-1	<i>6-Lane Divided Arterial</i>
MVSI-103D-0	<i>Mixed-Use Boulevard</i>
MVSI-104A-1	<i>Arterial</i>
MVSI-104B-1	<i>Alternate Arterial</i>
MVSI-104C-1	<i>Sunnymead Boulevard (Frederick Street to Graham Street)</i>
MVSI-104D-1	<i>Sunnymead Boulevard (Graham Street to Heacock Street) (Indian Street to Perris Boulevard)</i>
MVSI-104E-1	<i>Sunnymead Boulevard (Heacock Street to Indian Street)</i>
MVSI-105A-2	<i>Minor Arterial</i>
MVSI-105B-1	<i>Alternate Minor Arterial</i>
MVSI-105C-1	<i>Pigeon Pass Road</i>
MVSI-106A-1	<i>Industrial Collector</i>
MVSI-106B-0	<i>Collector</i>
MVSI-106C-0	<i>Neighborhood Collector</i>
MVSI-107A-0	<i>Local Street</i>
MVSI-107B-0	<i>Modified Local Street</i>
MVSI-107C-0	<i>Rural Street</i>
MVSI-107D-0	<i>All Weather Transportation Surface</i>
MVSI-108A-0	<i>Hillside Residential Street</i>
MVSI-108B-0	<i>Hillside Collector Street</i>
MVSI-109A-0	<i>Local and Collector Street Bridge</i>
MVSI-109B-0	<i>Minor Arterial Bridge</i>
MVSI-109C-0	<i>Arterial Bridge</i>
MVSI-110-0	<i>Two-Way Bike Path on Separate Right-of-Way</i>

#### Sidewalks, Driveways, and Ramps

MVSI-111A-0	<i>Residential Driveway Approach (For Right-Of-Way Width behind Curb of 10' or More)</i>
-------------	--

# City of Moreno Valley

## Standard Plans Index - 2022 Edition

---

**SECTION 1:      Street Improvements (Continued)**

MVSI-111B-0	<i>Residential Driveway Approach (For Confined Right-Of-Way)</i>
MVSI-111C-1	<i>Residential Driveway Approach (For Confined Right-Of-Way)</i>
MVSI-112A-0	<i>Commercial Driveway Approach: Type 1</i>
MVSI-112B-0	<i>Commercial Driveway Approach: Type 2</i>
MVSI-112C-0	<i>Commercial Driveway Approach: Type 3</i>
MVSI-112D-0	<i>Commercial Driveway Approach: Type 4</i>
MVSI-113-0	<i>Alley Approach</i>
MVSI-114A-2	<i>Access Ramp: Type 1</i>
MVSI-114B-2	<i>Access Ramp: Type 2</i>
MVSI-114C-2	<i>Detectable Warning Surface Details and Notes</i>
MVSI-114D-0	<i>Access Ramp – Alternate Type 2 (Confined Space)</i>
MVSI-115A-0	<i>Sidewalk</i>
MVSI-115B-0	<i>Curb Separated Sidewalk</i>
MVSI-115C-0	<i>Meandering Sidewalk</i>
MVSI-115D-0	<i>Sidewalk Placement around Obstructions</i>
MVSI-116A-0	<i>News Rack Installation and Placement</i>
MVSI-116B-0	<i>News Rack Installation Notes</i>
MVSI-117A-0	<i>Single Post Mailbox Installation</i>
MVSI-117B-0	<i>Multiple Mailbox Installation for New Sidewalk</i>
MVSI-118A-0	<i>Tree Well: Type 1</i>
MVSI-118B-0	<i>Tree Well: Type 2</i>
MVSI-118C-0	<i>Tree Well: Type 3</i>
MVSI-118D-0	<i>Tree Well: Type 4</i>
MVSI-118E-0	<i>Tree Well Notes</i>
MVSI-119-0	<i>Parkway Improvement Spacing</i>

Curb and Gutter

MVSI-120A-0	<i>Type 6 Integral Curb and Gutter</i>
MVSI-120B-0	<i>Type 8 Integral Curb and Gutter</i>
MVSI-121A-0	<i>Type 6A Curb</i>
MVSI-121B-0	<i>Type 8A Curb</i>
MVSI-122-0	<i>Type D-1 Curb</i>
MVSI-123-0	<i>Type C Rolled Curb</i>
MVSI-124-0	<i>Asphalt Concrete Curb</i>
MVSI-125-0	<i>Curb Transition</i>
MVSI-126-0	<i>Curb Address Painting</i>
MVSI-127-1	<i>Cross Gutter and Spandrel</i>

Pavement

MVSI-130-0	<i>Pavement Edge Taper</i>
MVSI-131-0	<i>Join Existing Pavement Detail</i>
MVSI-132A-2	<i>Perpendicular Trench Backfill and Roadway Repair</i>



# City of Moreno Valley

## Standard Plans Index - 2022 Edition

---

### **SECTION 1: Street Improvements (Continued)**

<i>MVSI-132B-3</i>	<i>Parallel Trench Backfill and Roadway Repair</i>
<i>MVSI-132C-3</i>	<i>Trench Backfill and Roadway Repair Notes</i>
<i>MVSI-132D-1</i>	<i>Utility Pothole or Pavement Core Repair</i>
<i>MVSI-132E-2</i>	<i>Water Line (Up to 12" Dia) Trench Backfill and Roadway Repair</i>
<i>MVSI-132F-2</i>	<i>Water Line (Larger than 12" Dia) Trench Backfill and Roadway</i>
<i>MVSI-132G-0</i>	<i>Repair Micro-Trenching and Join Existing Pavement Detail</i>
<i>MVSI-133-0</i>	<i>Recessed Trench Plate Detail</i>
<i>MVSI-134A-0</i>	<i>Speed Hump Detail and Placement</i>
<i>MVSI-134B-0</i>	<i>Speed Hump Installation Notes</i>
<i>MVSI-135-0</i>	<i>Speed Table</i>
<i>MVSI-136A-0</i>	<i>Speed Cushion Detail 36</i>
<i>MVSI-136B-0</i>	<i>Speed Cushion Detail 40</i>
<i>MVSI-136C-0</i>	<i>Speed Cushion Detail 44</i>
<i>MVSI-136D-0</i>	<i>Speed Cushion Notes</i>

#### Median

<i>MVSI-140-0</i>	<i>Emergency Vehicle Median Access</i>
<i>MVSI-141A-0</i>	<i>Median Landscape Meandering Design</i>
<i>MVSI-141B-0</i>	<i>Median Landscape Meandering Design Notes</i>
<i>MVSI-142A-1</i>	<i>Median Hardscape Meandering Design</i>
<i>MVSI-142B-1</i>	<i>Median Hardscape Meandering Design Notes</i>
<i>MVSI-143-0</i>	<i>Median Taper</i>
<i>MVSI-144-0</i>	<i>Median Flare</i>
<i>MVSI-145-0</i>	<i>Restricted Left Turn Median Opening</i>
<i>MVSI-146-0</i>	<i>Aligned Opposite Driveways Restricted Left Turn Median</i>
<i>MVSI-147A-0</i>	<i>Manhole / Curb Conflict with Median Access</i>
<i>MVSI-147B-0</i>	<i>Manhole / Curb Conflict with Median Access</i>

#### Parkway and Residential Yard Drain

<i>MVSI-150A-0</i>	<i>Parkway Culvert</i>
<i>MVSI-150B-0</i>	<i>Parkway Culvert Details and Notes</i>
<i>MVSI-151A-0</i>	<i>Sidewalk Outlet Structure</i>
<i>MVSI-151B-0</i>	<i>Sidewalk Outlet Structure Notes</i>
<i>MVSI-152-1</i>	<i>Curb Drain: Residential</i>
<i>MVSI-153A-1</i>	<i>Typical Lot Drainage and Residential Yard Drain</i>
<i>MVSI-153B-0</i>	<i>Residential Yard Drain – B1 Typical Area Drain</i>
<i>MVSI-153C-0</i>	<i>Residential Yard Drain – B2 Typical Drain Downspout Inlet Detail</i>

#### Design and Construction Policies and Guidelines

<i>MVSI-160A-1</i>	<i>Design Policy</i>
<i>MVSI-160B-1</i>	<i>Design Policy</i>
<i>MVSI-160C-1</i>	<i>Roadway Design Requirements</i>
<i>MVSI-161-0</i>	<i>Bus Turnout</i>
<i>MVSI-162-0</i>	<i>Knuckle</i>
<i>MVSI-163A-0</i>	<i>Cul-de-Sac (Symmetrical)</i>
<i>MVSI-163B-0</i>	<i>Cul-de-Sac (Offset)</i>

# City of Moreno Valley

## Standard Plans Index - 2022 Edition

---

### **SECTION 1: Street Improvements (Continued)**

<i>MVSI-164A-0</i>	<i>Intersection Sight Distance</i>
<i>MVSI-164B-0</i>	<i>Intersection Sight Distance</i>
<i>MVSI-164C-0</i>	<i>Intersection Sight Distance</i>
<i>MVSI-165-0</i>	<i>Property Line: Corner Cut-Back, Curb Return Radius</i>
<i>MVSI-166A-1</i>	<i>Standard General Notes (For Land Development Division)</i>
<i>MVSI-166B-2</i>	<i>Standard Street Improvement Notes (For Land Development Division)</i>
<i>MVSI-166C-2</i>	<i>Standard Grading Notes (For Land Development Division)</i>
<i>MVSI-166D-2</i>	<i>Standard Precise Grading Notes (For Land Development Division)</i>
<i>MVSI-167A-0</i>	<i>General Street Improvements Notes (For City Capital Improvement Projects)</i>
<i>MVSI-167B-0</i>	<i>General Street Improvements Notes (For City Capital Improvement Projects)</i>
<i>MVSI-168A-1</i>	<i>Standard Title Sheet (For Land Development Division)</i>
<i>MVSI-168B-1</i>	<i>Standard Title Sheet (For City Capital Improvement Projects)</i>

#### Monument

<i>MVSI-170A-1</i>	<i>Monument Cover</i>
<i>MVSI-170B-0</i>	<i>Survey Monument</i>
<i>MVSI-170C-0</i>	<i>Tie-out Standards</i>
<i>MVSI-170D-0</i>	<i>Street Centerline Monument</i>
<i>MVSI-170E-0</i>	<i>Monument Notes</i>

#### Utilities

<i>MVSI-180A-1</i>	<i>Normal Location of Underground Utilities</i>
<i>MVSI-180B-1</i>	<i>Location of Cable TV Ducts at Street Intersections</i>
<i>MVSI-181A-1</i>	<i>Communications Conduit in Parkway Separate Trench Detail</i>
<i>MVSI-181B-1</i>	<i>Communications Conduit in Sidewalk Separate Trench Detail</i>
<i>MVSI-181C-1</i>	<i>Communications Conduit in Pavement Separate Trench Detail</i>
<i>MVSI-181D-1</i>	<i>Typical Multi-Conduit Joint Trench Detail</i>
<i>MVSI-182-1</i>	<i>Telecommunications Trunk Conduit System and Pull Box Layout Detail</i>
<i>MVSI-183-1</i>	<i>Telecommunications Distribution and Service Lateral Conduit System</i>
<i>MVSI-184A-1</i>	<i>Telecommunications Residential Units</i>
<i>MVSI-184B-1</i>	<i>Telecommunications Residential Units</i>
<i>MVSI-185A-1</i>	<i>Telecommunication Technical Provisions</i>
<i>MVSI-185B-1</i>	<i>Telecommunication Technical Provisions</i>
<i>MVSI-185C-1</i>	<i>Telecommunication Technical Provisions</i>
<i>MVSI-185D-1</i>	<i>Telecommunication Technical Provisions</i>
<i>MVSI-186-1</i>	<i>Citywide Communication Conduits</i>

2:1	Slope of two feet measured horizontally for every one foot measured vertically	Max	Maximum
&	And	M.B.	Map Book
@	At	MH	Manhole
%	Percent	Min	Minimum
AB	Aggregate Base	Mon	Monument
AC	Asphalt Concrete	MUTCD	Manual on Uniform Traffic Control Devices
A.C.P.	Asbestos Cement Pipe	N	North
BC	Begin Curve	No.	Number
BCR	Begin Curb Return	NTS	Not to Scale
Bit.	Bituminous	OC	On Center
Bldg.	Building	OG	Original Ground
BM	Bench Mark	PB	Pull Box
BOW	Back of Walk	PC	Point of Curvature
BVC	Begin Vertical Curve	PCC	Point of Compound Curve
CAB	Crush Aggregate Base	PI	Point of Intersection
CB	Catch Basin	PL, PL	Property Line
C-C	Center to Center	PP	Power Pole
CF	Curb Face	PRC	Point of Reverse Curve
C.I.	Cast Iron	PVC	Polyvinyl Chloride
C.M.P.	Corrugated Metal Pipe	PVI	Point of Vertical Intersection
CO	Cleanout	Pvmt	Pavement
Conc	Concrete	Qty	Quantity
Constr	Construct	R	Radius
C.U.P.	Conditional Use Permit	RCB	Reinforced Concrete Box
CL, CL	Center line	RCP	Reinforced Concrete Pipe
DA	Drive Approach	Rdwy	Roadway
Dia	Diameter	Ret	Retaining
DMH	Drop Manhole	R/S	Record of Survey
Dwy	Driveway	Rt.	Right
E	East	R/W, ROW	Right of Way
EC	End Curve	S	South, Sewer
ECR	End Curb Return	SD	Storm Drain
EL	Elevation	Sht	Sheet
EP, EOP	Edge of Pavement	SL	Street Light
ETW	Edge of Traveled Way	SMH	Sewer Manhole
EVC	End Vertical Curve	Spec	Specifications, Special
Ex, Exist	Existing	SS	Sanitary Sewer
F.B.	Field Book	Sta	Station
FG	Finished Grade	Std	Standard
FH	Fire Hydrant	Sdwb, S/W	Sidewalk
FL, FL	Flow Line	T	Tangent Length for Curve
FOW	Front of Walk	TB	Top of Berm
FS	Finished Surface	TC	Top of Curb
GB	Grade Break	TG	Top of Grade
G.L.	Ground Line	Tr.	Tract
G.P.	Grading Plan	TS	Traffic Signal
HGL	Hydraulic Grade Line	Typ	Typical
HP	High Point	VC	Vertical Curve
Inv	Invert	VCP	Vitrified Clay Pipe
IE	Invert Elevation	W	West or Width
L	Length or Length of Arc	WV	Water Valve
Lt.	Left		

NOT TO SCALE

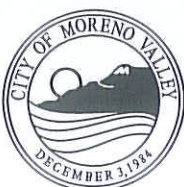

RECOMMENDED:  
  
 DIVISION MANAGER      DATE 1/21/14

APPROVED:  
  
 PUBLIC WORKS DIRECTOR / DATE 1/29/14  
 CITY ENGINEER















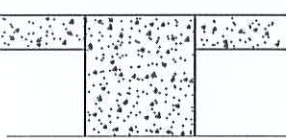

**CITY OF MORENO VALLEY**  
 PUBLIC WORKS DEPARTMENT - LAND DEVELOPMENT DIVISION

**ACRONYMS AND ABBREVIATIONS**

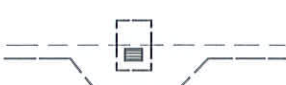

STANDARD PLAN

**MVSI-010A-0**

SHEET 1 OF 4

	CENTER LINE
	POINT OF INTERSECTION
	RIGHT OF WAY, PROPERTY LINE
	EXISTING CURB
	NEW CURB
	EXISTING CURB AND GUTTER
	NEW CURB AND GUTTER
	EXISTING SIDEWALK
	NEW CONCRETE SIDEWALK
	NEW CONCRETE DRIVEWAY
	NEW PAVEMENT
	NEW PAVEMENT TO BE OVERLAID OVER EXISTING PAVEMENT
	EXISTING REINFORCED CONCRETE PIPE OR STORM DRAIN
	EXISTING CORRUGATED METAL PIPE OR STORM DRAIN
	EXISTING CURB INLET
	EXISTING CURB INLET WITH GRATING
	NEW STORM DRAIN, CURB INLET AND GUTTER DEPRESSION

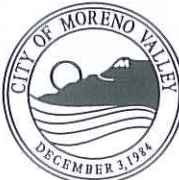

















NOT TO SCALE

	RECOMMENDED:  DIVISION MANAGER DATE: 1/29/14	<b>CITY OF MORENO VALLEY</b> PUBLIC WORKS DEPARTMENT - LAND DEVELOPMENT DIVISION  <b>DRAFTING STANDARDS          AND TOPO SYMBOLS</b>	STANDARD PLAN <b>MVSI-010B-0</b>
	APPROVED:  PUBLIC WORKS DIRECTOR / CITY ENGINEER DATE: 1/29/14		SHEET 2 OF 4





——— Δ" \* ——— UTILITY LINE ( Δ" = SIZE OF UTILITY LINE, \* = LISTED BELOW)

E = ELECTRICAL	S = SEWER
F = FUEL	SD = STORM DRAIN
FO = FIBER OPTICS	T = TELEPHONE
G = GAS	TV = TELEVISION CABLE
I = IRRIGATION	W = WATER
O = OIL	X = INDUSTRIAL WASTE

-  WATER METER
-  WATER VALVE
-  FIRE HYDRANT
-  TELEPHONE POLE
-  POLE ANCHOR
-  GUY POLE
-  TELEPHONE AND POWER ON SAME POLE
-  EXISTING STREET LIGHT
-  NEW STREET LIGHT
-  EXISTING TRAFFIC SIGNAL
-  EXISTING TRAFFIC SIGNAL DETECTOR
-  EXISTING TRAFFIC SIGNAL CONTROLLER
-  PULL BOX
-  NEW SIGN
-  NEW INFORMATIONAL SIGN
-  EXISTING STREET NAME SIGN
-  NEW STREET NAME SIGN
-  EXISTING HEDGE
-  SHRUB

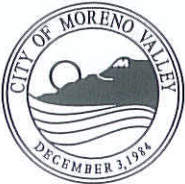
NOT TO SCALE

	RECOMMENDED:  DIVISION MANAGER	1/21/14 DATE	<b>CITY OF MORENO VALLEY</b> PUBLIC WORKS DEPARTMENT - LAND DEVELOPMENT DIVISION
	APPROVED:  PUBLIC WORKS DIRECTOR / CITY ENGINEER	1/29/14 DATE	<b>DRAFTING STANDARDS                  AND TOPO SYMBOLS</b>



EXISTING TREE



PROPOSED TREE



PALM TREE

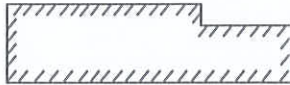

BUILDING



MONUMENT



EXISTING NATURAL FLOW LINE

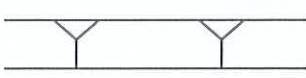

TOP OF SLOPE



TOE OF SLOPE



DIRECTION OF FLOW



FENCE

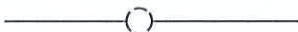

EXISTING MANHOLE



EXISTING SEWER CLEANOUT



NEW SANITARY SEWER AND MANHOLE



NEW SEWER CLEANOUT



NEW SANITARY SEWER MAIN WITH WYES AND LATERAL

**PROFILE SYMBOLS**

 EXISTING PAVEMENT PROFILE

 EXISTING CURB PROFILE

 EXISTING SIDEWALK PROFILE

 EXISTING GROUND PROFILE

 FINISHED CENTERLINE GRADE

 TOP OF CURB GRADE

 BACK OF SIDEWALK GRADE

 POINT OF INTERSECTION



NEW CULVERT OR  
STORM DRAIN AND  
CURB INLET



EXISTING SANITARY  
SEWER, MANHOLE  
AND CLEANOUT

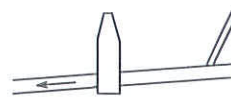

NEW SANITARY  
SEWER, MANHOLE  
AND CLEANOUT

NOT TO SCALE



RECOMMENDED:  
  
DIVISION MANAGER DATE 1/23/14

APPROVED:  
  
PUBLIC WORKS DIRECTOR / DATE  
CITY ENGINEER

**CITY OF MORENO VALLEY**  
PUBLIC WORKS DEPARTMENT - LAND DEVELOPMENT DIVISION

**DRAFTING STANDARDS  
AND TOPO SYMBOLS**

STANDARD PLAN  
**MVSI-010D-0**

SHEET 4 OF 4

# STREET CLASSIFICATION AND CROSS SECTION DESIGN STANDARDS

STANDARD CITY PLAN No	STREET CLASS	ROW/ CURB TO CURB (FT)	TYPICAL SECTION (PARKING, TRAVEL LANES & MEDIAN) (FT)	PARKWAY WIDTH (FT)	THRU LANES	LOS C CAPACITY (ADT)	TRAFFIC INDEX (TI) ▲▲	MIN BUS BAY WIDTH (FT)	MIN THICKNESS AC OVER CAB
MVSI-101A, MVSI-101B	DIVIDED MAJOR ARTERIAL	134/110 (RAISED MEDIAN)	8   12   12   14   18   14   12   12   8	12 **	6 ▲	45,000	10	10	.50/1.00 ▲▲▲
	ALT	142/110							
MVSI-102A, MVSI-102B	MODIFIED DIVIDED MAJOR ARTERIAL	120/102 (RAISED MEDIAN)	8   12   12   12   14   12   12   12   8	9 **	6 ▲	45,000	10	10	.50/1.00 ▲▲▲
	ALT	130/102							
MVSI-103A, MVSI-103B	4-LANE DIVIDED MAJOR ARTERIAL	110/86 (RAISED MEDIAN)	8   12   14   18   14   12   8	12 **	4 ▲	30,000	10	10	.50/1.00 ▲▲▲
	ALT	114/86							
MVSI-103C	6-LANE DIVIDED MAJOR ARTERIAL	110/86 (RAISED MEDIAN)	13   11   12   14   12   11   13	12	6	45,000	10	10	.50/1.00 ▲▲▲
MVSI-103D	MIXED-USE BOULEVARD	110/86 (RAISED MEDIAN)	12   12   12   14   12   12   12	12	6	45,000	10	10	.50/1.00 ▲▲▲
MVSI-104A, MVSI-104B	ARTERIAL	100/76	8   12   12   12   12   12   8	12 **	4 ▲	20,000	10	10	.50/1.00 ▲▲▲
	ALT	104/76	6   12   13   14   13   12   6			30,000			
MVSI-105A, MVSI-105B	MINOR ARTERIAL	88/64	8   12   12   12   12   12   8						
			6   11   10   10   10   11   6	12 **	4	20,000	9	10	.45/75 ▲▲▲
			7   10   10   10   10   10   7						
MVSI-105C	PIGEON PASS ROAD	98/74	6   13   12   12   12   13   6	12	4 ▲	20,000	9	10	.45/75 ▲▲▲
MVSI-106A	INDUSTRIAL COLLECTOR	78/56	10   12   12   12   10	11	2 ▲	10,000	10	10	.50/1.00 ▲▲▲
MVSI-106B	COLLECTOR	66/44	8   14   14   8	11	2	N/A	7	N/A	.30/50
MVSI-106C	NEIGHBORHOOD COLLECTOR	66/44	11   11   11   11	11	4	N/A	10	10	.50/1.00
MVSI-107A	LOCAL STREET	56/36	7   11   11   7	10	2	N/A	6	N/A	.30/50
MVSI-107B	MODIFIED LOCAL STREET	50/36	7   11   11   7	7	2	N/A	6	N/A	.30/50
MVSI-104C, MVSI-104D, MVSI-104E	SUNNYMEAD BOULEVARD	100/72	20   12   12   12   16	12/16	4	30,000	10	10	.50/1.00
		100/68	16   12   12   12   16	16	4	30,000	10	10	.50/1.00
		100/68	16   12   12   12   16	16	4	30,000	10	10	.50/1.00
			6   11   11   12   11   11   6						

NOT TO SCALE

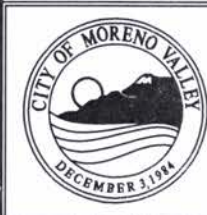

RECOMMENDED:  
*Wei Sun* 10/31/23  
 PRINCIPAL ENGINEER DATE  
 APPROVED:  
*[Signature]*  
 PUBLIC WORKS DIRECTOR/ DATE  
 CITY ENGINEER

## CITY OF MORENO VALLEY

PUBLIC WORKS DEPARTMENT - TRANSPORTATION ENGINEERING DIVISION

### STREET CLASSIFICATION AND CROSS SECTION DESIGN STANDARDS

STANDARD PLAN

### MVSI-100A-3

SHEET 1 OF 2

\* MAY BE USED FOR CUL-DE-SACS WITH LESS THAN 10 LOTS BUT WILL NOT BE CONSIDERED FOR NEW DEVELOPMENT PROJECTS.

\*\* PARKWAY WIDTH FOR ALTERNATE STREET CROSS SECTIONS ARE AS FOLLOWS:

- |  |      |
|--|------|
| 1. ALTERNATE DIVIDED MAJOR ARTERIAL          | 16FT |
| 2. ALTERNATE MODIFIED DIVIDED MAJOR ARTERIAL | 14FT |
| 3. ALTERNATE DIVIDED ARTERIAL                | 14FT |
| 4. ALTERNATE ARTERIAL                        | 14FT |
| 5. ALTERNATE MINOR ARTERIAL                  | 14FT |

\*\*\* ROW REQUIREMENTS SHALL BE BASED UPON AN ALIGNMENT STUDY AS APPROVED BY THE CITY ENGINEER. INCREASED WIDTH MAY BE REQUIRED TO ACCOMMODATE ADDITIONAL TURN LANES.

\*\*\*\* PAINTED MEDIAN.

\*\*\*\*\* RAISED MEDIAN, LOCATIONS DETERMINED ON A CASE-BY-CASE BASIS.

▲ LEFT TURN LANES OR POCKETS WITHOUT ELIMINATING PARKING.

▲▲ STREETS DESIGNATED AS TRUCK ROUTES SHALL HAVE A MINIMUM TI OF 12, SUBJECT TO CITY ENGINEER APPROVAL.

▲▲▲ STREETS DESIGNATED AS TRUCK ROUTES SHALL HAVE A MINIMUM THICKNESS AC OVER CAB OF 0.67/1.00' R-VALUE = 50 MAXIMUM

CASE A: WITH RIGHT TURN LANE

CASE B: WITH LEFT TURN LANE

**NOTES:**

1. PARKING MAY BE ELIMINATED ON SOME STREETS AND CLASS II BIKEWAYS STRIPED, SEE GENERAL PLAN.
2. PARKING MAY BE ELIMINATED AT INTERSECTION APPROACHES TO ACCOMMODATE TURN POCKETS.
3. ALL OF THE ABOVE LANE WIDTHS SHALL BE USED TO DESIGN STRIPING PLANS UNLESS OTHERWISE DIRECTED BY THE CITY ENGINEER.

NOT TO SCALE

	RECOMMENDED: <i>W. Sun</i> 2/1/2022 DIVISION MANAGER DATE	<b>CITY OF MORENO VALLEY</b> PUBLIC WORKS DEPARTMENT - TRANSPORTATION ENGINEERING DIVISION	STANDARD PLAN
	APPROVED: <i>[Signature]</i> 2/4/22 PUBLIC WORKS DIRECTOR / DATE CITY ENGINEER		<b>STREET CLASSIFICATION AND CROSS SECTION DESIGN STANDARDS NOTES</b>
			SHEET 2 OF 2



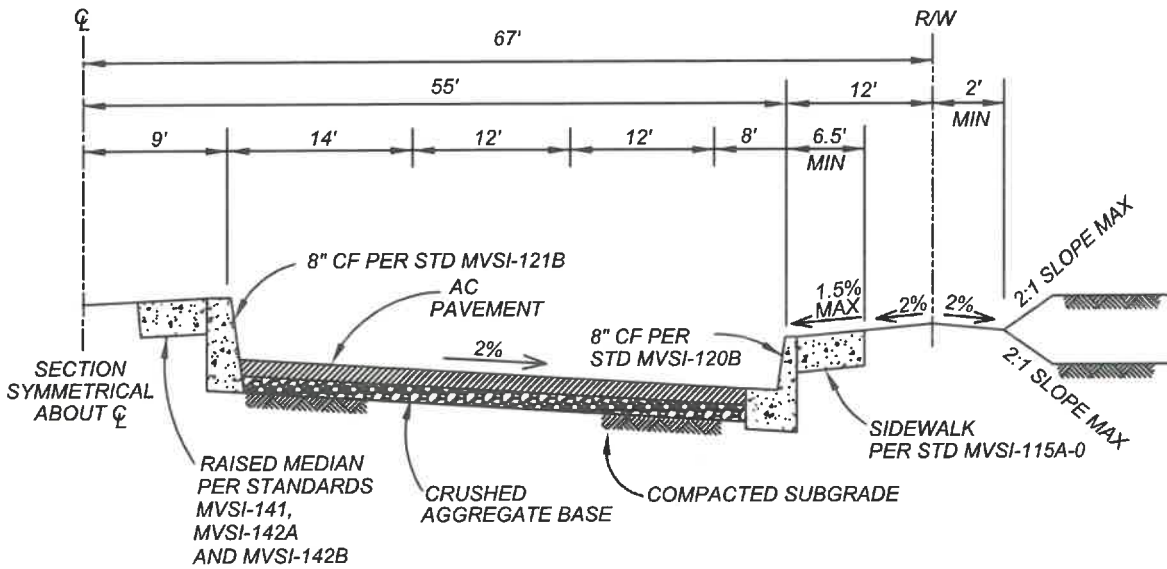

**TYPICAL SECTION**

**NOTES:**

- 1.) ADDITIONAL RIGHT-OF-WAY MAY BE REQUIRED WHEN AN ARTERIAL HIGHWAY COINCIDES WITH AN ADOPTED ROUTE FOR AN ADDITIONAL PUBLIC FACILITY (I.E., PEDESTRIAN, BICYCLE, OR EQUESTRIAN TRAIL), OR FOR A SCENIC HIGHWAY.
- 2.) THICKNESS OF PAVEMENT SECTION TO BE DETERMINED BY R-VALUE TESTING PER CALTRANS DESIGN METHOD TEST 301 WITH RECOMMENDED SAFETY FACTOR, MINIMUM 0.50' AC / 1.00' CAB\*. R-VALUE = 50 MAXIMUM. AC SHALL BE PLACED IN LIFTS, AND THICKNESS OF EACH LIFT SHALL NOT EXCEED 3".
- 3.) MINIMUM TI = 10, TRUCK ROUTES SHALL BE 12.
- 4.) HALF WIDTH STREETS SHALL BE CONSTRUCTED TO A WIDTH OF 1/2 STREET PLUS 23' WITH MEDIAN. \*\*

\* MINIMUM 0.67' AC / 1.00' CAB ON STREETS DESIGNATED AS TRUCK ROUTES

\*\* UNLESS OTHERWISE DIRECTED BY CITY ENGINEER

NOT TO SCALE



RECOMMENDED:  
*Wei Sun* 2/1/2022  
 DIVISION MANAGER DATE  
 APPROVED:  
*[Signature]* 2/1/22  
 PUBLIC WORKS DIRECTOR / DATE  
 CITY ENGINEER

**CITY OF MORENO VALLEY**

PUBLIC WORKS DEPARTMENT - TRANSPORTATION ENGINEERING DIVISION

**DIVIDED MAJOR ARTERIAL**

STANDARD PLAN

**MVSI-101A-1**

SHEET 1 OF 2

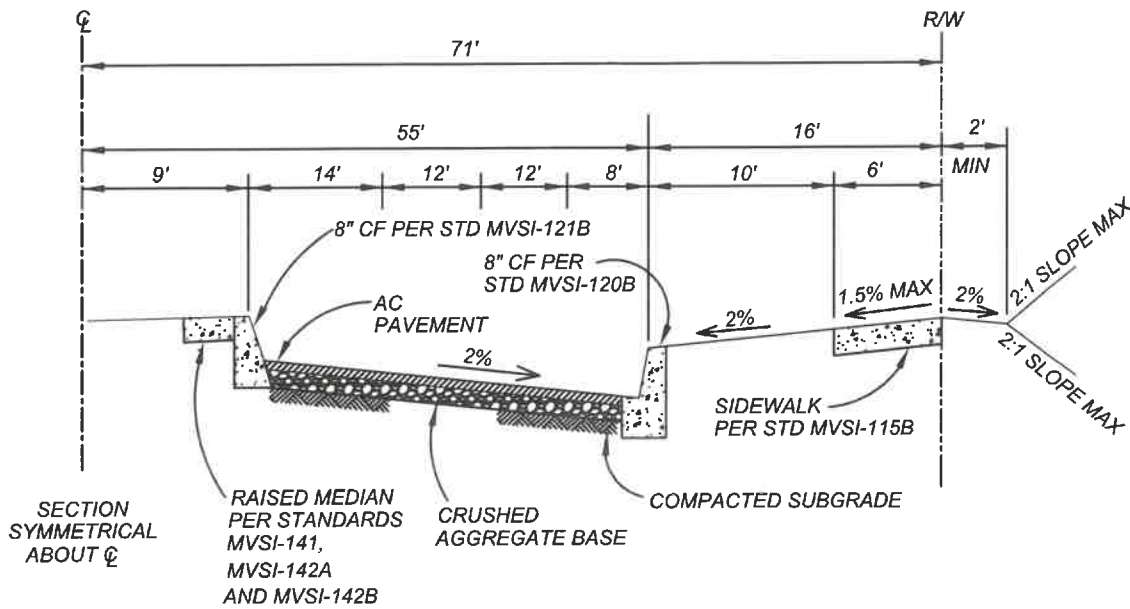

### TYPICAL SECTION

**NOTES:**

- 1.) ADDITIONAL RIGHT-OF-WAY MAY BE REQUIRED WHEN AN ARTERIAL HIGHWAY COINCIDES WITH AN ADOPTED ROUTE FOR AN ADDITIONAL PUBLIC FACILITY (I.E., PEDESTRIAN, BICYCLE, OR EQUESTRIAN TRAIL), OR FOR A SCENIC HIGHWAY.
- 2.) THICKNESS OF PAVEMENT SECTION TO BE DETERMINED BY R-VALUE TESTING PER CALTRANS DESIGN METHOD TEST 301 WITH RECOMMENDED SAFETY FACTOR, MINIMUM 0.50' AC / 1.00' CAB\*. R-VALUE = 50 MAXIMUM. AC SHALL BE PLACED IN LIFTS, AND THICKNESS OF EACH LIFT SHALL NOT EXCEED 3".
- 3.) MINIMUM TI = 10, TRUCK ROUTES SHALL BE 12.
- 4.) HALF WIDTH STREETS SHALL BE CONSTRUCTED TO A WIDTH OF 1/2 STREET PLUS 23' WITH MEDIAN.\*\*
- 5.) ALTERNATE DIVIDED MAJOR ARTERIAL IS TO BE USED IN THE FOLLOWING CIRCUMSTANCES:
  - a.) SPECIFIC PLANS OR OTHER LARGE RESIDENTIAL, INDUSTRIAL, OR COMMERCIAL DEVELOPMENTS WHERE ADDITIONAL RIGHT-OF-WAY CAN BE ACCOMMODATED OVER THE BREADTH OF A LARGE AREA, CAUSING LESS CONFLICT WITH MINIMUM LOT SIZE OR OTHER DEVELOPMENT REQUIREMENTS.
  - b.) WHERE CONFLICTS WITH UTILITIES EXIST (E.G., THE 30" HIGH PRESSURE GAS MAIN RUNNING ALONG THE NORTH SIDE OF COTTONWOOD AV; THE HIGHGROVE HIGH VOLTAGE TRANSMISSION LINE RUNNING DOWN PIGEON PASS RD/FREDERICK ST).
  - c.) WHERE PARKWAYS MUST BE EXPANDED TO ALLOW FOR ADDITIONAL PUBLIC FACILITIES.
  - d.) OTHER LOCATIONS AS APPROVED BY THE CITY ENGINEER.

\* MINIMUM 0.67' AC / 1.00' CAB ON STREETS DESIGNATED AS TRUCK ROUTES  
 \*\* UNLESS OTHERWISE DIRECTED BY CITY ENGINEER

NOT TO SCALE

	RECOMMENDED: <i>Wei Sun</i> 2/1/2022 DIVISION MANAGER DATE	<b>CITY OF MORENO VALLEY</b> PUBLIC WORKS DEPARTMENT - TRANSPORTATION ENGINEERING DIVISION	
	APPROVED: <i>[Signature]</i> 2/4/22 PUBLIC WORKS DIRECTOR / DATE CITY ENGINEER	<b>ALTERNATE DIVIDED MAJOR ARTERIAL</b>	

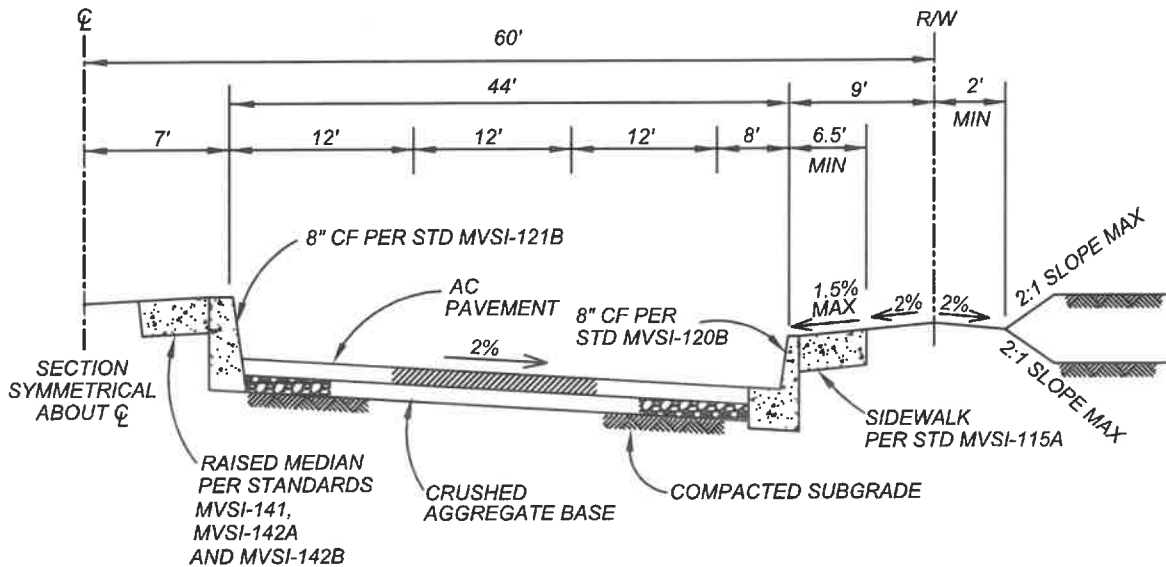

**TYPICAL SECTION**

**NOTES:**

- 1.) ADDITIONAL RIGHT-OF-WAY MAY BE REQUIRED WHEN AN ARTERIAL HIGHWAY COINCIDES WITH AN ADOPTED ROUTE FOR AN ADDITIONAL PUBLIC FACILITY (I.E., PEDESTRIAN, BICYCLE, OR EQUESTRIAN TRAIL), OR FOR A SCENIC HIGHWAY.
- 2.) THICKNESS OF PAVEMENT SECTION TO BE DETERMINED BY R-VALUE TESTING PER CALTRANS DESIGN METHOD TEST 301 WITH RECOMMENDED SAFETY FACTOR, MINIMUM 0.50' AC / 1.00' CAB\*. R-VALUE = 50 MAXIMUM. AC SHALL BE PLACED IN LIFT, AND THICKNESS OF EACH LIFT SHALL NOT EXCEED 3".
- 3.) MINIMUM TI = 10, TRUCK ROUTES SHALL BE 12.
- 4.) HALF WIDTH STREETS SHALL BE CONSTRUCTED TO A WIDTH OF 1/2 STREET WIDTH PLUS 21' WITH MEDIAN.

\* MINIMUM 0.67' AC / 1.00' CAB ON STREETS DESIGNATED AS TRUCK ROUTES

NOT TO SCALE



RECOMMENDED:  
*Wili San* 2/4/2022  
 DIVISION MANAGER DATE  
 APPROVED:  
*[Signature]* 2/4/22  
 PUBLIC WORKS DIRECTOR / DATE  
 CITY ENGINEER

**CITY OF MORENO VALLEY**  
 PUBLIC WORKS DEPARTMENT - TRANSPORTATION ENGINEERING DIVISION

**MODIFIED DIVIDED MAJOR  
 ARTERIAL**

STANDARD PLAN  
**MVSI-102A-1**  
 SHEET 1 OF 2

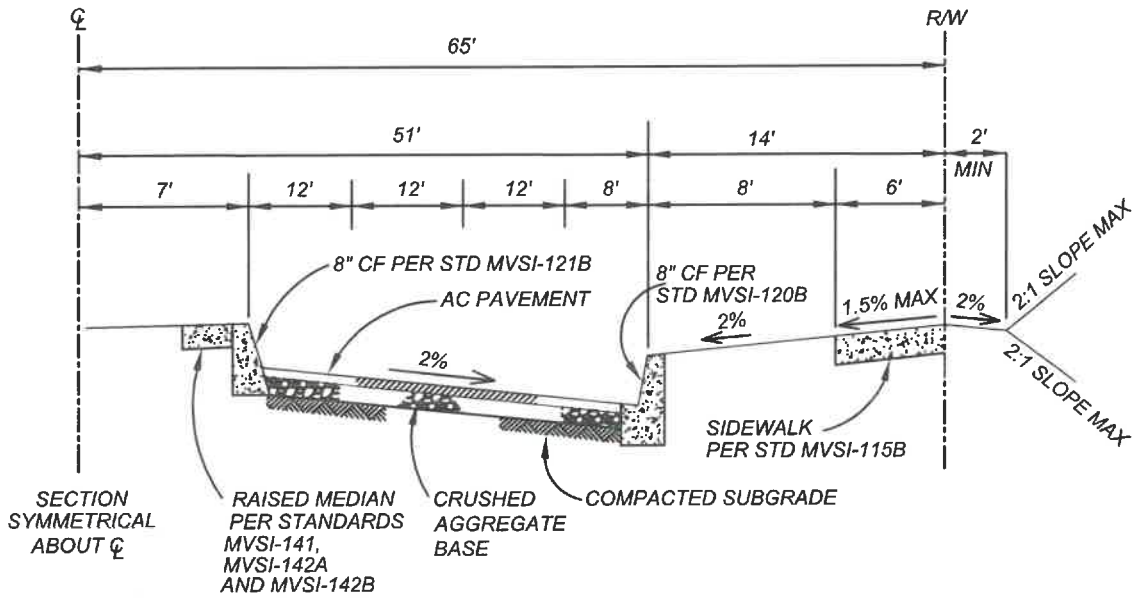

### TYPICAL SECTION

**NOTES:**

- 1.) ADDITIONAL RIGHT-OF-WAY MAY BE REQUIRED WHEN AN ARTERIAL HIGHWAY COINCIDES WITH AN ADOPTED ROUTE FOR AN ADDITIONAL PUBLIC FACILITY (I.E., PEDESTRIAN, BICYCLE, OR EQUESTRIAN TRAIL), OR FOR A SCENIC HIGHWAY.
- 2.) THICKNESS OF PAVEMENT SECTION TO BE DETERMINED BY R-VALUE TESTING PER CALTRANS DESIGN METHOD TEST 301 WITH RECOMMENDED SAFETY FACTOR, MINIMUM 0.50' AC / 1.00' CAB\*. R-VALUE = 50 MAXIMUM. AC SHALL BE PLACED IN LIFTS, AND THICKNESS OF EACH LIFT SHALL NOT EXCEED 3".
- 3.) MINIMUM TI = 10, TRUCK ROUTES SHALL BE 12.
- 4.) HALF WIDTH STREETS SHALL BE CONSTRUCTED TO A WIDTH OF 1/2 STREET WIDTH PLUS 21' WITH MEDIAN.
- 5.) ALTERNATE MODIFIED DIVIDED MAJOR ARTERIAL IS TO BE USED IN THE FOLLOWING CIRCUMSTANCES:
  - a.) SPECIFIC PLANS OR OTHER LARGE RESIDENTIAL, INDUSTRIAL, OR COMMERCIAL DEVELOPMENTS WHERE ADDITIONAL RIGHT-OF-WAY CAN BE ACCOMMODATED OVER THE BREADTH OF A LARGE AREA, CAUSING LESS CONFLICT WITH MINIMUM LOT SIZE OR OTHER DEVELOPMENT REQUIREMENTS.
  - b.) WHERE CONFLICTS WITH UTILITIES EXIST (E.G., THE 30" HIGH PRESSURE GAS MAIN RUNNING ALONG THE NORTH SIDE OF COTTONWOOD AV; THE HIGHGROVE HIGH VOLTAGE TRANSMISSION LINE RUNNING DOWN PIGEON PASS RD/FREDERICK ST).
  - c.) WHERE PARKWAYS MUST BE EXPANDED TO ALLOW FOR ADDITIONAL PUBLIC FACILITIES.
  - d.) OTHER LOCATIONS AS APPROVED BY THE CITY ENGINEER.

\* MINIMUM 0.67' AC / 1.00' CAB ON STREETS DESIGNATED AS TRUCK ROUTES

NOT TO SCALE



RECOMMENDED:  
*Wes Sun* 2/1/22  
 DIVISION MANAGER DATE  
 APPROVED:  
*[Signature]* 2/4/22  
 PUBLIC WORKS DIRECTOR / DATE  
 CITY ENGINEER

**CITY OF MORENO VALLEY**  
 PUBLIC WORKS DEPARTMENT - TRANSPORTATION ENGINEERING DIVISION

**ALTERNATE MODIFIED DIVIDED MAJOR ARTERIAL**

STANDARD PLAN  
**MVSI-102B-1**  
 SHEET 2 OF 2

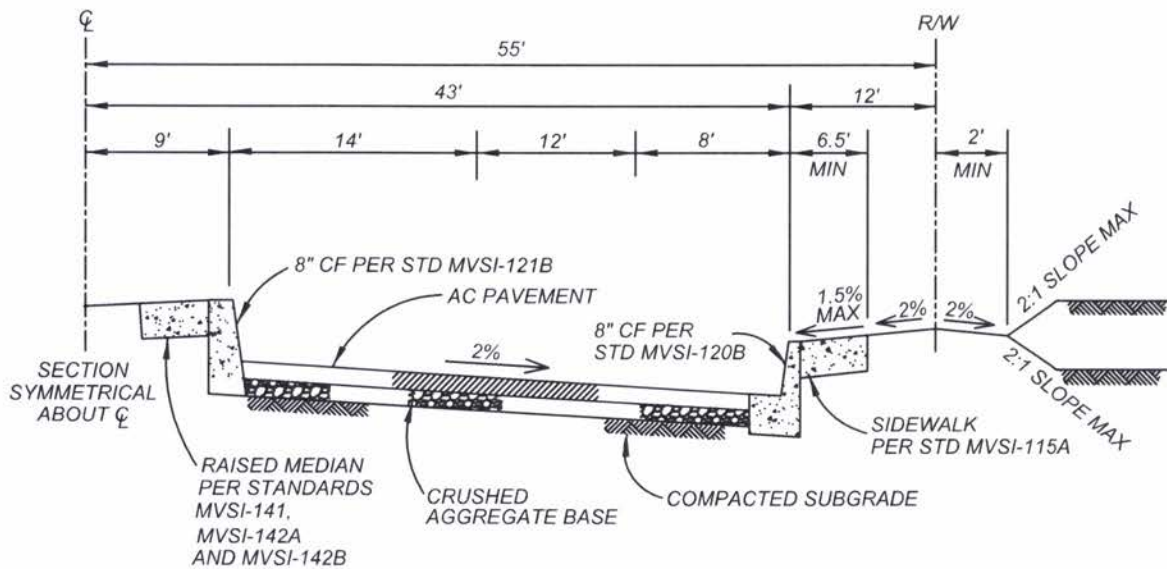

**TYPICAL SECTION**

**NOTES:**

- 1.) ADDITIONAL RIGHT-OF-WAY MAY BE REQUIRED WHEN AN ARTERIAL HIGHWAY COINCIDES WITH AN ADOPTED ROUTE FOR AN ADDITIONAL PUBLIC FACILITY (I.E., PEDESTRIAN, BICYCLE, OR EQUESTRIAN TRAIL), OR FOR A SCENIC HIGHWAY.
- 2.) THICKNESS OF PAVEMENT SECTION TO BE DETERMINED BY R-VALUE TESTING PER CALTRANS DESIGN METHOD TEST 301 WITH RECOMMENDED SAFETY FACTOR, MINIMUM 0.50' AC / 1.00' CAB\*. R-VALUE = 50 MAXIMUM. AC SHALL BE PLACED IN LIFTS, AND THICKNESS OF EACH LIFT SHALL NOT EXCEED 3".
- 3.) MINIMUM TI = 10, TRUCK ROUTES SHALL BE 12.
- 4.) HALF WIDTH STREETS SHALL BE CONSTRUCTED TO A WIDTH OF 1/2 STREET WIDTH PLUS 23' WITH MEDIAN.

\* MINIMUM 0.67' AC / 1.00' CAB ON STREETS DESIGNATED AS TRUCK ROUTES

NOT TO SCALE

	RECOMMENDED: <i>W. S. Smith</i> 10/31/23 PRINCIPAL ENGINEER      DATE	<b>CITY OF MORENO VALLEY</b> PUBLIC WORKS DEPARTMENT - TRANSPORTATION ENGINEERING DIVISION	
	APPROVED: <i>W. S. Smith</i> 10/31/23 PUBLIC WORKS DIRECTOR / DATE CITY ENGINEER	<b>4-LANE DIVIDED ARTERIAL</b>	



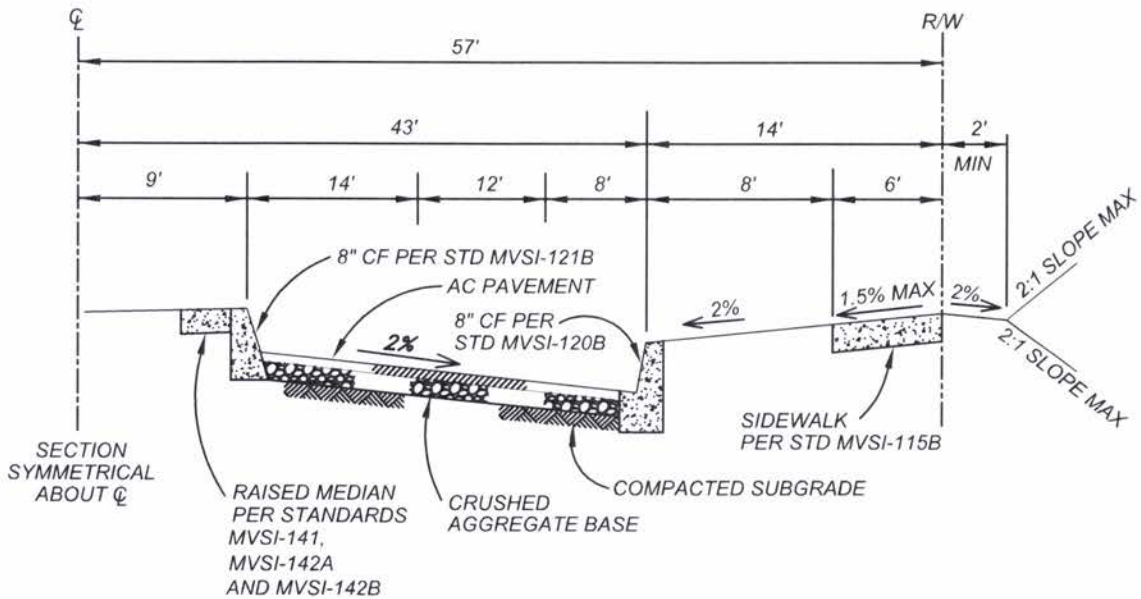

**TYPICAL SECTION**

**NOTES:**

- 1.) ADDITIONAL RIGHT-OF-WAY MAY BE REQUIRED WHEN AN ARTERIAL HIGHWAY COINCIDES WITH AN ADOPTED ROUTE FOR AN ADDITIONAL PUBLIC FACILITY (I.E., PEDESTRIAN, BICYCLE, OR EQUESTRIAN TRAIL), OR FOR A SCENIC HIGHWAY.
- 2.) THICKNESS OF PAVEMENT SECTION TO BE DETERMINED BY R-VALUE TESTING PER CALTRANS DESIGN METHOD TEST 301 WITH RECOMMENDED SAFETY FACTOR, MINIMUM 0.50' AC / 1.00' CAB\*. R-VALUE = 50 MAXIMUM. AC SHALL BE PLACED IN LIFTS, AND THICKNESS OF EACH LIFT SHALL NOT EXCEED 3".
- 3.) MINIMUM TI = 10, TRUCK ROUTES SHALL BE 12.
- 4.) HALF WIDTH STREETS SHALL BE CONSTRUCTED TO A WIDTH OF 1/2 STREET WIDTH PLUS 23' WITH MEDIAN.
- 5.) ALTERNATE DIVIDED ARTERIAL IS TO BE USED IN THE FOLLOWING CIRCUMSTANCES:
  - a.) SPECIFIC PLANS OR OTHER LARGE RESIDENTIAL, INDUSTRIAL, OR COMMERCIAL DEVELOPMENTS WHERE ADDITIONAL RIGHT-OF-WAY CAN BE ACCOMMODATED OVER THE BREADTH OF A LARGE AREA, CAUSING LESS CONFLICT WITH MINIMUM LOT SIZE OR OTHER DEVELOPMENT REQUIREMENTS.
  - b.) WHERE CONFLICTS WITH UTILITIES EXIST (E.G., THE 30" HIGH PRESSURE GAS MAIN RUNNING ALONG THE NORTH SIDE OF COTTONWOOD AV; THE HIGHGROVE HIGH VOLTAGE TRANSMISSION LINE RUNNING DOWN PIGEON PASS RD/FREDERICK ST).
  - c.) WHERE PARKWAYS MUST BE EXPANDED TO ALLOW FOR ADDITIONAL PUBLIC FACILITIES.
  - d.) OTHER LOCATIONS AS APPROVED BY THE CITY ENGINEER.

\* MINIMUM 0.67' AC / 1.00' CAB ON STREETS DESIGNATED AS TRUCK ROUTES

NOT TO SCALE

	RECOMMENDED: <i>We. Sim</i> 10/31/23 PRINCIPAL ENGINEER / DATE	<b>CITY OF MORENO VALLEY</b> PUBLIC WORKS DEPARTMENT - TRANSPORTATION ENGINEERING DIVISION	
	APPROVED: <i>[Signature]</i> 10/31/23 PUBLIC WORKS DIRECTOR / DATE CITY ENGINEER	<b>ALTERNATE DIVIDED ARTERIAL</b>	
SHEET 2 OF 4			

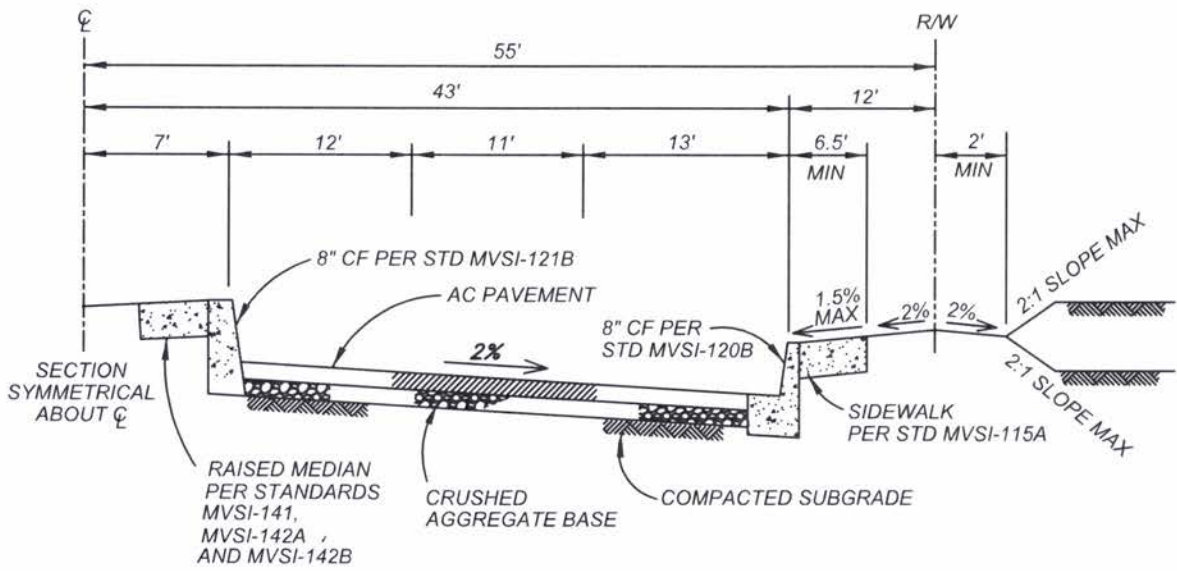

**TYPICAL SECTION**

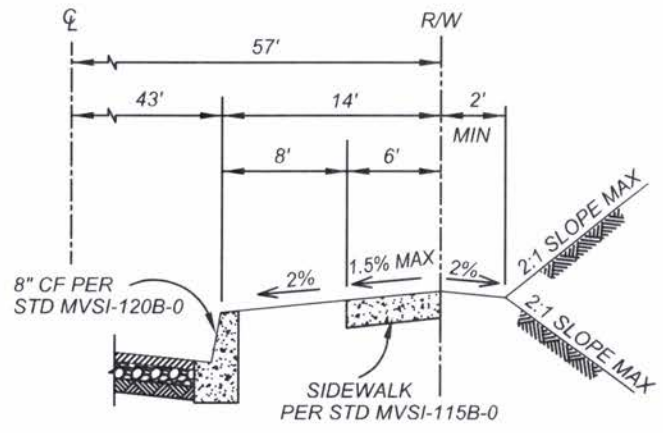

**ALTERNATE SECTION**

**NOTES:**

- 1.) ADDITIONAL RIGHT-OF-WAY MAY BE REQUIRED WHEN AN ARTERIAL HIGHWAY COINCIDES WITH AN ADOPTED ROUTE FOR AN ADDITIONAL PUBLIC FACILITY (I.E., PEDESTRIAN, BICYCLE, OR EQUESTRIAN TRAIL), OR FOR A SCENIC HIGHWAY.
- 2.) THICKNESS OF PAVEMENT SECTION TO BE DETERMINED BY R-VALUE TESTING PER CALTRANS DESIGN METHOD TEST 301 WITH RECOMMENDED SAFETY FACTOR, MINIMUM 0.50' AC / 1.00' CAB\*. R-VALUE = 50 MAXIMUM. AC SHALL BE PLACED IN LIFTS, AND THICKNESS OF EACH LIFT SHALL NOT EXCEED 3".
- 3.) MINIMUM TI = 10, TRUCK ROUTES SHALL BE 12.
- 4.) HALF WIDTH STREETS SHALL BE CONSTRUCTED TO A WIDTH OF 1/2 STREET WIDTH PLUS 19' WITH MEDIAN.

\* MINIMUM 0.67' AC / 1.00' CAB ON STREETS DESIGNATED AS TRUCK ROUTES

NOT TO SCALE

	RECOMMENDED: <i>W. S. Smith</i> 10/21/23 PRINCIPAL ENGINEER / DATE	<b>CITY OF MORENO VALLEY</b> PUBLIC WORKS DEPARTMENT - TRANSPORTATION ENGINEERING DIVISION
	APPROVED: <i>W. S. Smith</i> 10/31/23 PUBLIC WORKS DIRECTOR / DATE CITY ENGINEER	<b>6-LANE DIVIDED ARTERIAL</b>

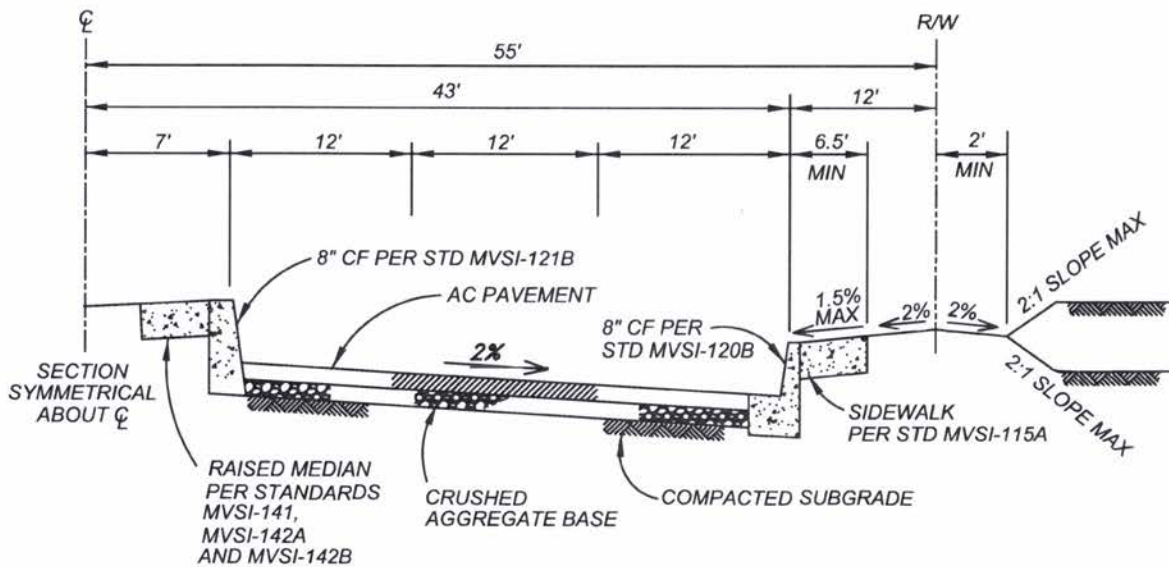

**TYPICAL SECTION**

**NOTES:**

- 1.) ADDITIONAL RIGHT-OF-WAY MAY BE REQUIRED WHEN AN ARTERIAL HIGHWAY COINCIDES WITH AN ADOPTED ROUTE FOR AN ADDITIONAL PUBLIC FACILITY (I.E., PEDESTRIAN, BICYCLE, OR EQUESTRIAN TRAIL), OR FOR A SCENIC HIGHWAY.
- 2.) THICKNESS OF PAVEMENT SECTION TO BE DETERMINED BY R-VALUE TESTING PER CALTRANS DESIGN METHOD TEST 301 WITH RECOMMENDED SAFETY FACTOR, MINIMUM 0.50' AC / 1.00' CAB\*. R-VALUE = 50 MAXIMUM. AC SHALL BE PLACED IN LIFTS, AND THICKNESS OF EACH LIFT SHALL NOT EXCEED 3".
- 3.) MINIMUM TI = 10, TRUCK ROUTES SHALL BE 12.
- 4.) HALF WIDTH STREETS SHALL BE CONSTRUCTED TO A WIDTH OF 1/2 STREET WIDTH PLUS 19' WITH MEDIAN.

\* MINIMUM 0.67' AC / 1.00' CAB ON STREETS DESIGNATED AS TRUCK ROUTES

NOT TO SCALE

	RECOMMENDED: <i>[Signature]</i> 10/31/23 PRINCIPAL ENGINEER      DATE	<b>CITY OF MORENO VALLEY</b> PUBLIC WORKS DEPARTMENT - TRANSPORTATION ENGINEERING DIVISION	
	APPROVED: <i>[Signature]</i> 10/31/23 PUBLIC WORKS DIRECTOR / DATE CITY ENGINEER	<b>MIXED-USE BOULEVARD</b>	



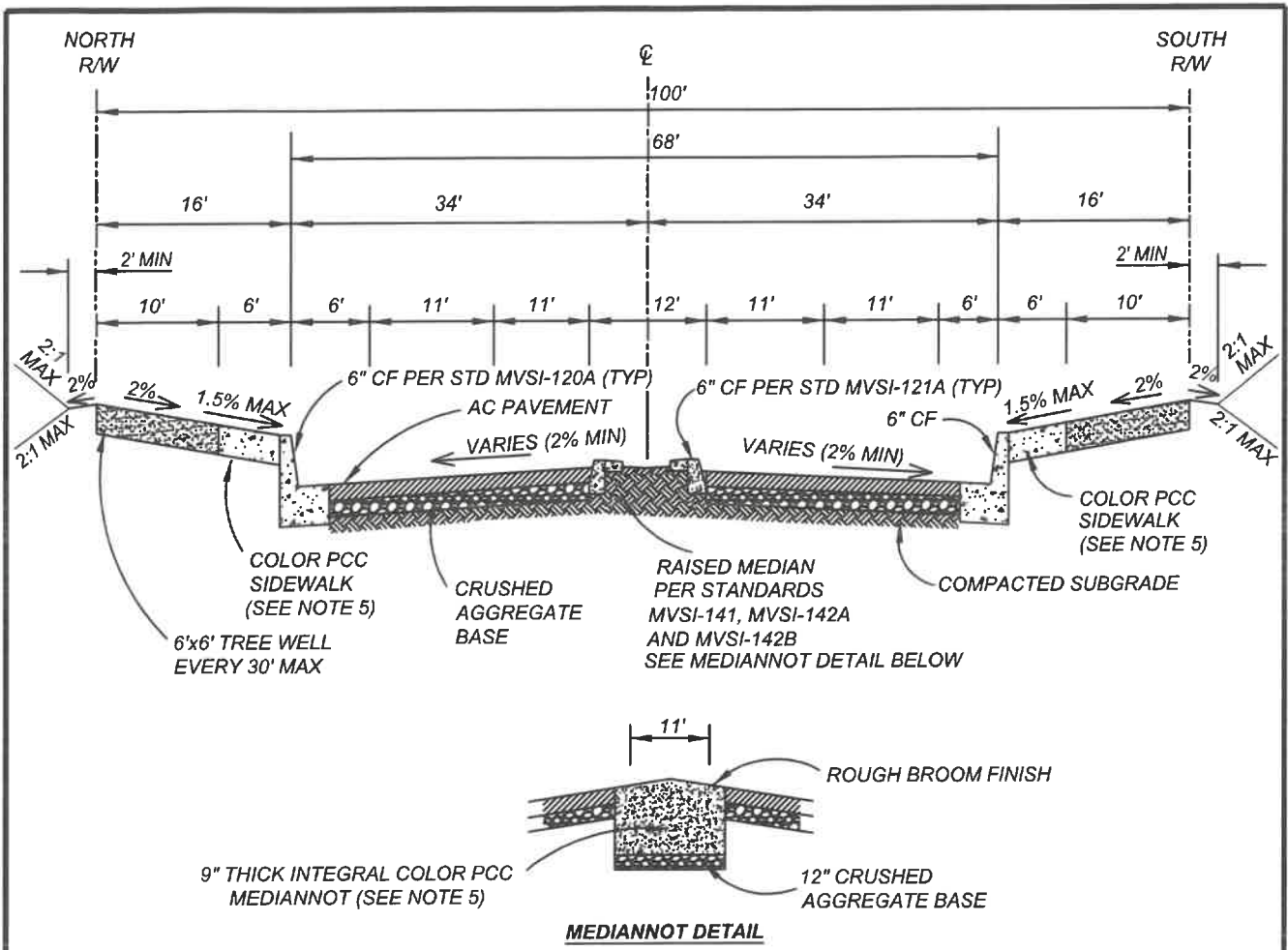

**GRAHAM STREET TO HEACOCK STREET AND INDIAN STREET TO PERRIS BOULEVARD**

**NOTES:**

- 1.) ADDITIONAL RIGHT-OF-WAY MAY BE REQUIRED WHEN AN ARTERIAL HIGHWAY COINCIDES WITH AN ADOPTED ROUTE FOR AN ADDITIONAL PUBLIC FACILITY (I.E., PEDESTRIAN, BICYCLE, OR EQUESTRIAN TRAIL), OR FOR A SCENIC HIGHWAY.
- 2.) THICKNESS OF PAVEMENT SECTION TO BE DETERMINED BY R-VALUE TESTING PER CALTRANS DESIGN METHOD TEST 301 WITH RECOMMENDED SAFETY FACTOR, MINIMUM 0.50' AC / 1.50' CAB. R-VALUE = 50 MAXIMUM. AC SHALL BE PLACED IN LIFTS, AND THICKNESS OF EACH LIFT SHALL NOT EXCEED 3".
- 3.) MINIMUM TI = 10, TRUCK ROUTES SHALL BE 12.
- 4.) PCC PAVEMENT DESIGN IS TO BE BASED ON SOIL SUBGRADE STRENGTH PARAMETERS WITH A MINIMUM PCC FLEXURAL STRENGTH OF 600 PSI AT 28 DAYS UTILIZING CONCRETE COMPRESSIVE STRENGTH OF 4,000 PSI AT 28 DAYS.
- 5.) MEDIANNOT IS AN INTEGRAL COLOR PCC TURN LANE. EXISTING COLOR IS ANTIQUE CORK BY L.M. SCOFIELD COMPANY.

NOT TO SCALE

	RECOMMENDED: <i>Wei Sun</i> 2/1/2022 DIVISION MANAGER DATE	<h2 style="margin: 0;">CITY OF MORENO VALLEY</h2> <p style="margin: 0;">PUBLIC WORKS DEPARTMENT - TRANSPORTATION ENGINEERING DIVISION</p>	STANDARD PLAN <b>MVS1-104D-1</b>
	APPROVED: <i>[Signature]</i> 2/4/22 PUBLIC WORKS DIRECTOR / DATE CITY ENGINEER	<p><b>SUNNYMEAD BOULEVARD</b>  <b>(GRAHAM STREET TO HEACOCK STREET)</b>  <b>(INDIAN STREET TO PERRIS BOULEVARD)</b></p>	SHEET 4 OF 5

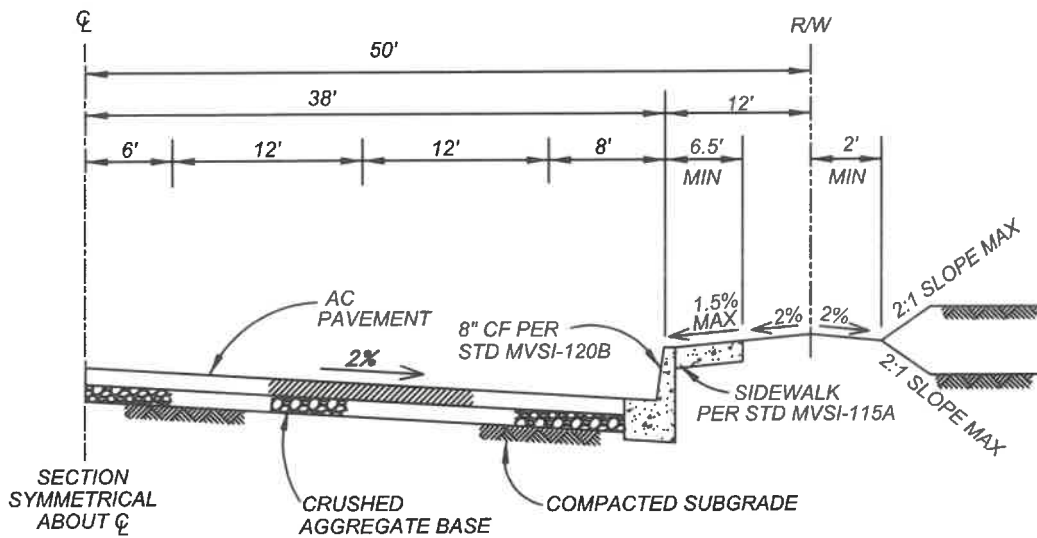

**TYPICAL SECTION**

**NOTES:**

- 1.) ADDITIONAL RIGHT-OF-WAY MAY BE REQUIRED WHEN AN ARTERIAL HIGHWAY COINCIDES WITH AN ADOPTED ROUTE FOR AN ADDITIONAL PUBLIC FACILITY (I.E., PEDESTRIAN, BICYCLE, OR EQUESTRIAN TRAIL) OR FOR A SCENIC HIGHWAY.
- 2.) THICKNESS OF PAVEMENT SECTION TO BE DETERMINED BY R-VALUE TESTING PER CALTRANS DESIGN METHOD TEST 301 WITH RECOMMENDED SAFETY FACTOR, MINIMUM 0.50' AC / 1.00' CAB\*. R-VALUE = 50 MAXIMUM. AC SHALL BE PLACED IN LIFTS, AND THICKNESS OF EACH LIFT SHALL NOT EXCEED 3".
- 3.) MINIMUM TI = 10, TRUCK ROUTES SHALL BE 12.
- 4.) HALF WIDTH STREETS SHALL BE CONSTRUCTED TO A WIDTH OF 1/2 STREET WIDTH PLUS 18'.

\* MINIMUM 0.67' AC / 1.00' CAB ON STREETS DESIGNATED AS TRUCK ROUTES

NOT TO SCALE

	RECOMMENDED: <i>Wesley Sam</i> 2/1/2022 <small>DIVISION MANAGER      DATE</small>	<h2 style="margin: 0;">CITY OF MORENO VALLEY</h2> <p style="margin: 0;">PUBLIC WORKS DEPARTMENT - TRANSPORTATION ENGINEERING DIVISION</p>	
	APPROVED: <i>[Signature]</i> 2/4/22 <small>PUBLIC WORKS DIRECTOR / DATE CITY ENGINEER</small>	<h3 style="margin: 0;">ARTERIAL</h3>	<small>STANDARD PLAN</small> <b>MVSI-104A-1</b>
	<small>SHEET 1 OF 5</small>		

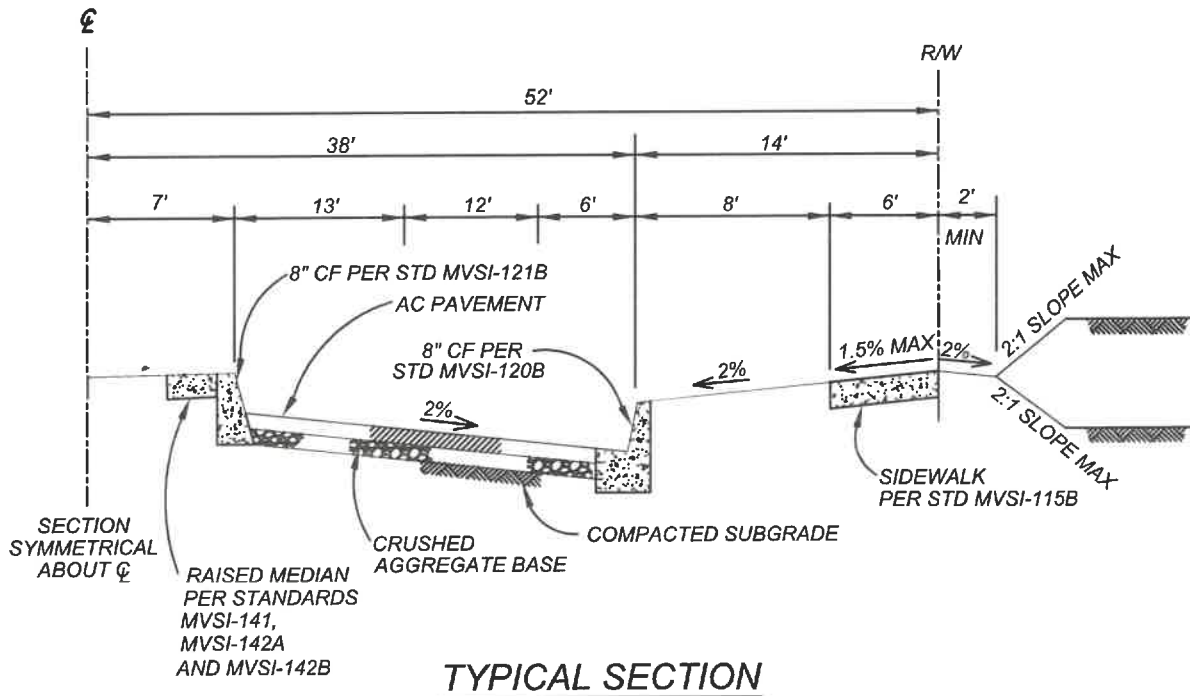

**NOTES:**

- 1.) ADDITIONAL RIGHT-OF-WAY MAY BE REQUIRED WHEN AN ARTERIAL HIGHWAY COINCIDES WITH AN ADOPTED ROUTE FOR AN ADDITIONAL PUBLIC FACILITY (I.E., PEDESTRIAN, BICYCLE, OR EQUESTRIAN TRAIL) OR FOR A SCENIC HIGHWAY.
- 2.) THICKNESS OF PAVEMENT SECTION TO BE DETERMINED BY R-VALUE TESTING PER CALTRANS DESIGN METHOD TEST 301 WITH RECOMMENDED SAFETY FACTOR, MINIMUM 0.50' AC / 1.00' CAB\*. R-VALUE = 50 MAXIMUM. AC SHALL BE PLACED IN LIFTS, AND THICKNESS OF EACH LIFT SHALL NOT EXCEED 3".
- 3.) MINIMUM TI = 10, TRUCK ROUTES SHALL BE 12.
- 4.) HALF WIDTH STREETS SHALL BE CONSTRUCTED TO A WIDTH OF 1/2 STREET WIDTH PLUS 18'.
- 5.) ALTERNATE ARTERIAL IS TO BE USED IN THE FOLLOWING CIRCUMSTANCES:
  - a.) SPECIFIC PLANS OR OTHER LARGE RESIDENTIAL, INDUSTRIAL, OR COMMERCIAL DEVELOPMENTS WHERE ADDITIONAL RIGHT-OF-WAY CAN BE ACCOMMODATED OVER THE BREADTH OF A LARGE AREA, CAUSING LESS CONFLICT WITH MINIMUM LOT SIZE OR OTHER DEVELOPMENT REQUIREMENTS.
  - b.) WHERE CONFLICTS WITH UTILITIES EXIST (E.G., THE 30" HIGH PRESSURE GAS MAIN RUNNING ALONG THE NORTH SIDE OF COTTONWOOD AV; THE HIGHGROVE HIGH VOLTAGE TRANSMISSION LINE RUNNING DOWN PIGEON PASS RD/FREDERICK ST).
  - c.) WHERE PARKWAYS MUST BE EXPANDED TO ALLOW FOR ADDITIONAL PUBLIC FACILITIES.
  - d.) OTHER LOCATIONS AS APPROVED BY THE CITY ENGINEER.

\* MINIMUM 0.67' AC / 1.00' CAB ON STREETS DESIGNATED AS TRUCK ROUTES

NOT TO SCALE

	RECOMMENDED: <i>Wesley Sam</i> 2/1/2022 <small>DIVISION MANAGER DATE</small>	<h2 style="margin: 0;">CITY OF MORENO VALLEY</h2> <p style="margin: 0;">PUBLIC WORKS DEPARTMENT - TRANSPORTATION ENGINEERING DIVISION</p>	<small>STANDARD PLAN</small> <b>MVSI-104B-1</b>
	APPROVED: <i>[Signature]</i> 2/4/22 <small>PUBLIC WORKS DIRECTOR/ DATE CITY ENGINEER</small>	<h3 style="margin: 0;">ALTERNATE ARTERIAL</h3>	<small>SHEET 2 OF 5</small>

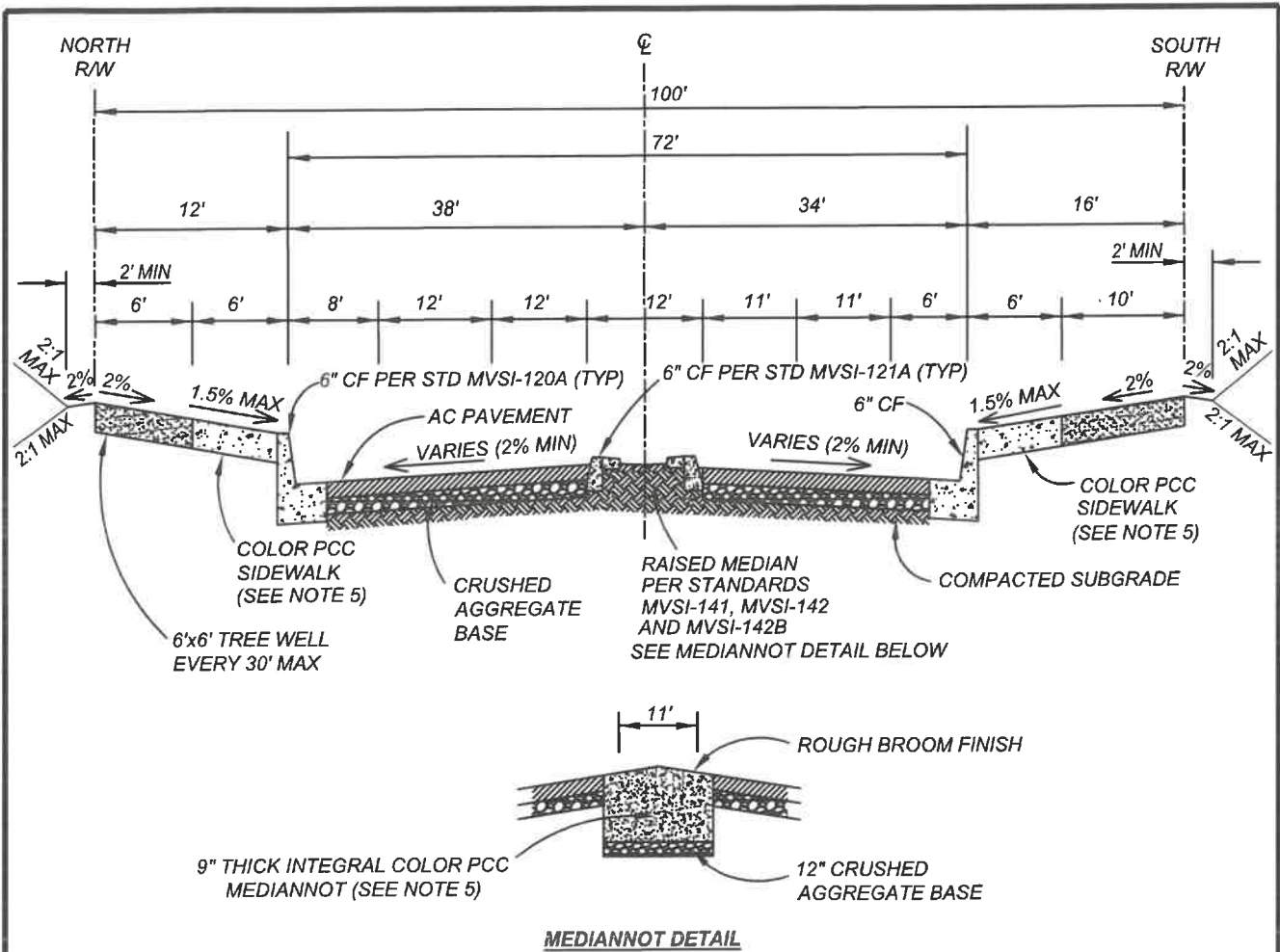

## FREDERICK STREET TO GRAHAM STREET

### NOTES:

- 1.) ADDITIONAL RIGHT-OF-WAY MAY BE REQUIRED WHEN AN ARTERIAL HIGHWAY COINCIDES WITH AN ADOPTED ROUTE FOR AN ADDITIONAL PUBLIC FACILITY (I.E., PEDESTRIAN, BICYCLE, OR EQUESTRIAN TRAIL), OR FOR A SCENIC HIGHWAY.
- 2.) THICKNESS OF PAVEMENT SECTION TO BE DETERMINED BY R-VALUE TESTING PER CALTRANS DESIGN METHOD TEST 301 WITH RECOMMENDED SAFETY FACTOR, MINIMUM 0.50' AC / 1.50' CAB. R-VALUE = 50 MAXIMUM. AC SHALL BE PLACED IN LIFTS, AND THICKNESS OF EACH LIFT SHALL NOT EXCEED 3".
- 3.) MINIMUM TI = 10, TRUCK ROUTES SHALL BE 12.
- 4.) PCC PAVEMENT DESIGN IS TO BE BASED ON SOIL SUBGRADE STRENGTH PARAMETERS WITH A MINIMUM PCC FLEXURAL STRENGTH OF 600 PSI AT 28 DAYS UTILIZING CONCRETE COMPRESSIVE STRENGTH OF 4,000 PSI AT 28 DAYS.
- 5.) MEDIANNOT IS AN INTEGRAL COLOR PCC TURN LANE. EXISTING COLOR IS ANTIQUE CORK BY L.M. SCOFIELD COMPANY.

NOT TO SCALE

	RECOMMENDED: <i>Wei Sun</i> 2/1/22 DIVISION MANAGER      DATE	<h1 style="margin: 0;">CITY OF MORENO VALLEY</h1> <p style="margin: 0;">PUBLIC WORKS DEPARTMENT - TRANSPORTATION ENGINEERING DIVISION</p>	STANDARD PLAN <b>MVSI-104C-1</b>
	APPROVED: <i>[Signature]</i> 2/4/22 PUBLIC WORKS DIRECTOR / DATE CITY ENGINEER	<h2 style="margin: 0;">SUNNYMEAD BOULEVARD (FREDERICK STREET TO GRAHAM STREET)</h2>	SHEET 3 OF 5



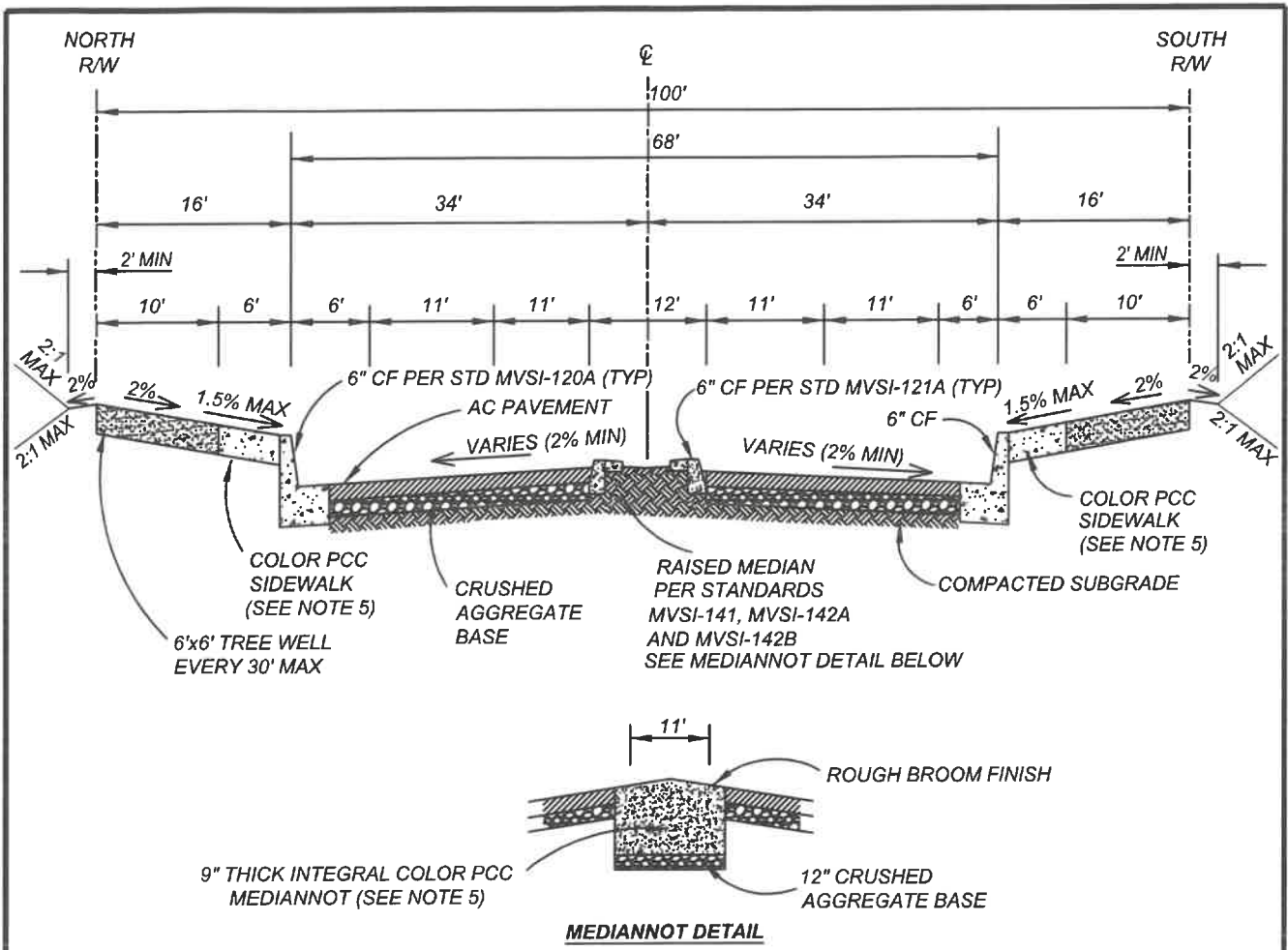

**GRAHAM STREET TO HEACOCK STREET AND INDIAN STREET TO PERRIS BOULEVARD**

**NOTES:**

- 1.) ADDITIONAL RIGHT-OF-WAY MAY BE REQUIRED WHEN AN ARTERIAL HIGHWAY COINCIDES WITH AN ADOPTED ROUTE FOR AN ADDITIONAL PUBLIC FACILITY (I.E., PEDESTRIAN, BICYCLE, OR EQUESTRIAN TRAIL), OR FOR A SCENIC HIGHWAY.
- 2.) THICKNESS OF PAVEMENT SECTION TO BE DETERMINED BY R-VALUE TESTING PER CALTRANS DESIGN METHOD TEST 301 WITH RECOMMENDED SAFETY FACTOR, MINIMUM 0.50' AC / 1.50' CAB. R-VALUE = 50 MAXIMUM. AC SHALL BE PLACED IN LIFTS, AND THICKNESS OF EACH LIFT SHALL NOT EXCEED 3".
- 3.) MINIMUM TI = 10, TRUCK ROUTES SHALL BE 12.
- 4.) PCC PAVEMENT DESIGN IS TO BE BASED ON SOIL SUBGRADE STRENGTH PARAMETERS WITH A MINIMUM PCC FLEXURAL STRENGTH OF 600 PSI AT 28 DAYS UTILIZING CONCRETE COMPRESSIVE STRENGTH OF 4,000 PSI AT 28 DAYS.
- 5.) MEDIANNOT IS AN INTEGRAL COLOR PCC TURN LANE. EXISTING COLOR IS ANTIQUE CORK BY L.M. SCOFIELD COMPANY.

NOT TO SCALE

	RECOMMENDED: <i>Wei Sun</i> 2/1/2022 DIVISION MANAGER DATE	<h2 style="margin: 0;">CITY OF MORENO VALLEY</h2> <p style="margin: 0;">PUBLIC WORKS DEPARTMENT - TRANSPORTATION ENGINEERING DIVISION</p>	
	APPROVED: <i>[Signature]</i> 2/4/22 PUBLIC WORKS DIRECTOR / DATE CITY ENGINEER	<p><b>SUNNYMEAD BOULEVARD</b>  <b>(GRAHAM STREET TO HEACOCK STREET)</b>  <b>(INDIAN STREET TO PERRIS BOULEVARD)</b></p>	STANDARD PLAN <p><b>MVS1-104D-1</b></p>

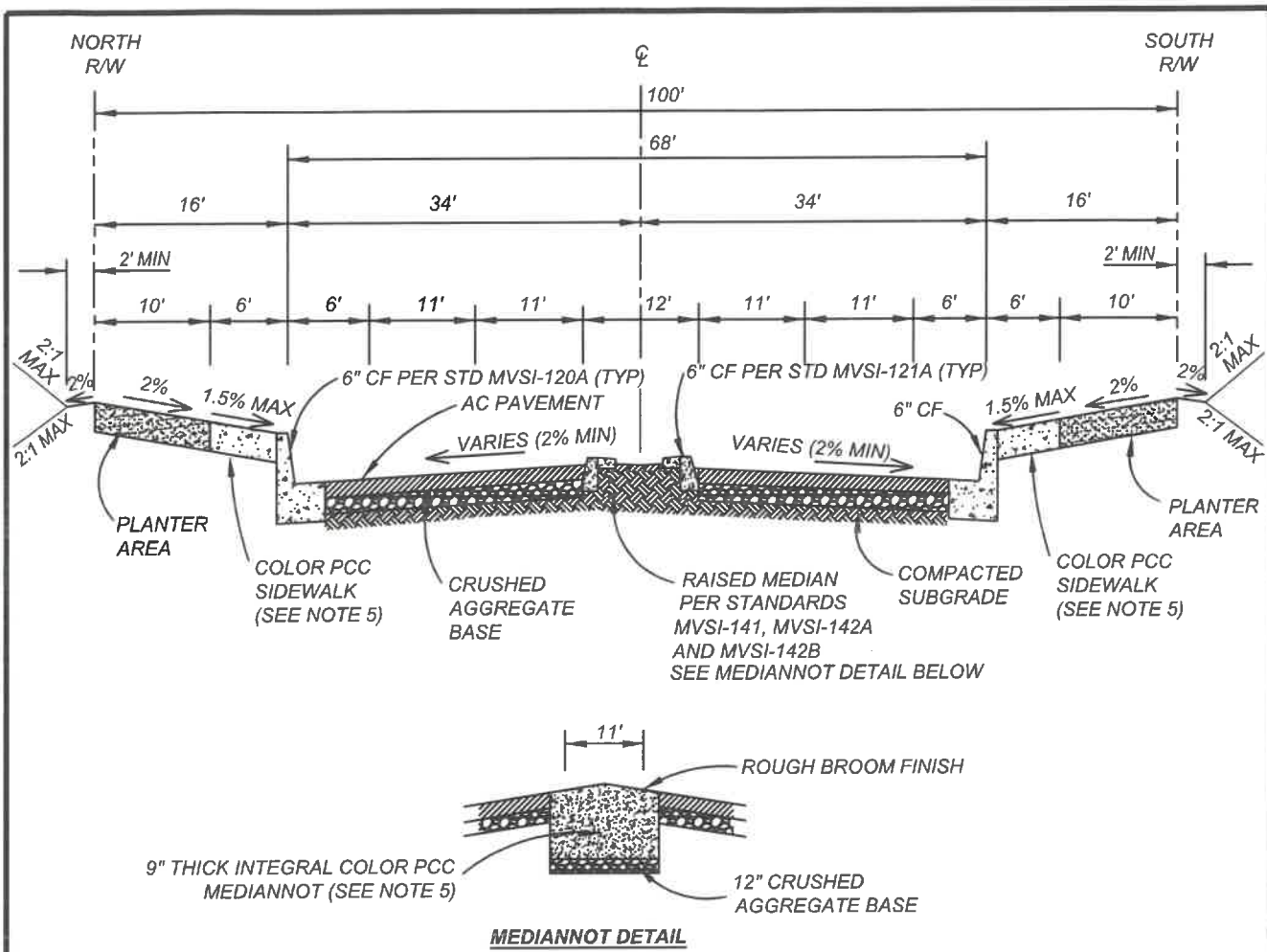

**"VILLAGE CENTER"  
HEACOCK STREET TO INDIAN STREET**

**NOTES:**

- 1.) ADDITIONAL RIGHT-OF-WAY MAY BE REQUIRED WHEN AN ARTERIAL HIGHWAY COINCIDES WITH AN ADOPTED ROUTE FOR AN ADDITIONAL PUBLIC FACILITY (I.E., PEDESTRIAN, BICYCLE, OR EQUESTRIAN TRAIL), OR FOR A SCENIC HIGHWAY.
- 2.) THICKNESS OF PAVEMENT SECTION TO BE DETERMINED BY R-VALUE TESTING PER CALTRANS DESIGN METHOD WITH RECOMMENDED SAFETY FACTOR, MINIMUM 0.50' AC / 1.50' CAB. R-VALUE = 50 MAXIMUM. AC SHALL BE PLACED IN LIFTS, AND THICKNESS OF EACH LIFT SHALL NOT EXCEED 3".
- 3.) MINIMUM TI = 10, TRUCK ROUTES SHALL BE 12.
- 4.) PCC PAVEMENT DESIGN IS TO BE BASED ON SOIL SUBGRADE STRENGTH PARAMETERS WITH A MINIMUM PCC FLEXURAL STRENGTH OF 600 PSI AT 28 DAYS UTILIZING CONCRETE COMPRESSIVE STRENGTH OF 4,000 PSI AT 28 DAYS.
- 5.) MEDIANNOT IS AN INTEGRAL COLOR PCC TURN LANE. EXISTING COLOR IS ANTIQUE CORK BY L.M. SCOFIELD COMPANY.

NOT TO SCALE

	RECOMMENDED: <i>Weisun</i> 2/1/2022 DIVISION MANAGER DATE	<b>CITY OF MORENO VALLEY</b> PUBLIC WORKS DEPARTMENT - TRANSPORTATION ENGINEERING DIVISION
	APPROVED:  2/4/22 PUBLIC WORKS DIRECTOR / DATE CITY ENGINEER	<b>SUNNYMEAD BOULEVARD (HEACOCK STREET TO INDIAN STREET)</b>

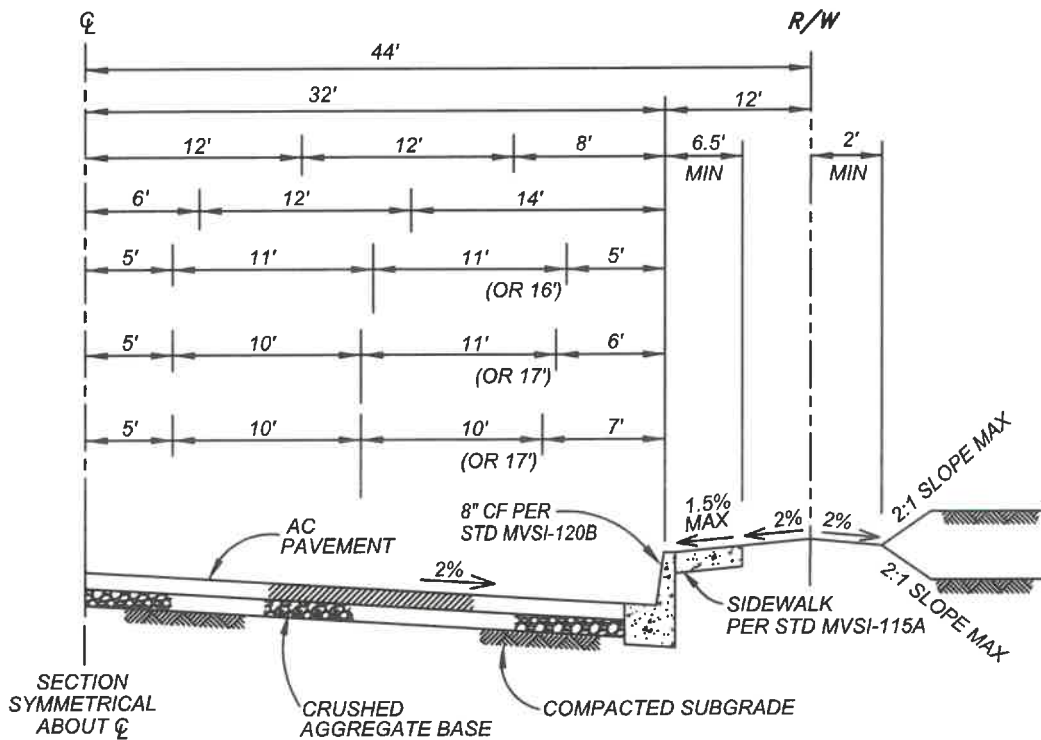

**TYPICAL SECTION**

**NOTES:**

- 1.) ADDITIONAL RIGHT-OF-WAY MAY BE REQUIRED WHEN AN ARTERIAL HIGHWAY COINCIDES WITH AN ADOPTED ROUTE FOR AN ADDITIONAL PUBLIC FACILITY (I.E., PEDESTRIAN, BICYCLE, OR EQUESTRIAN TRAIL), OR FOR A SCENIC HIGHWAY.
- 2.) THICKNESS OF PAVEMENT SECTION TO BE DETERMINED BY R-VALUE TESTING PER CALTRANS DESIGN METHOD TEST 301 WITH RECOMMENDED SAFETY FACTOR, MINIMUM 0.45' AC / 0.75' CAB\*. R-VALUE = 50 MAXIMUM. AC SHALL BE PLACED IN LIFTS, AND THICKNESS OF EACH LIFT SHALL NOT EXCEED 3".
- 3.) MINIMUM TI = 9, TRUCK ROUTES SHALL BE 12.
- 4.) HALF WIDTH STREETS SHALL BE CONSTRUCTED TO A WIDTH OF 1/2 STREET WIDTH PLUS 12' OR 18' (WITH DEDICATED TURN LANES).

\* MINIMUM 0.67' AC / 1.00' CAB ON STREETS DESIGNATED AS TRUCK ROUTES

NOT TO SCALE

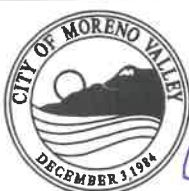
	RECOMMENDED: <i>Wei Sun</i> 2/4/2022 DIVISION MANAGER / DATE	<b>CITY OF MORENO VALLEY</b> PUBLIC WORKS DEPARTMENT - TRANSPORTATION ENGINEERING DIVISION	
	APPROVED: <i>[Signature]</i> 2/4/22 PUBLIC WORKS DIRECTOR / DATE CITY ENGINEER	<b>MINOR ARTERIAL</b>	STANDARD PLAN <b>MVSI-105A-2</b>
	SHEET 1 OF 3		

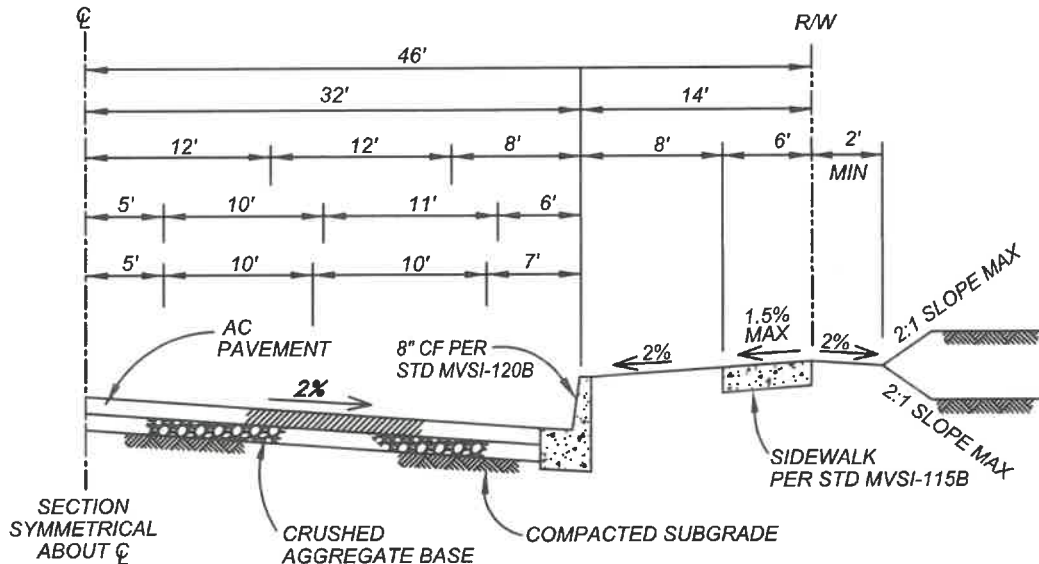



**TYPICAL SECTION**

**NOTES:**

- 1.) ADDITIONAL RIGHT-OF-WAY MAY BE REQUIRED WHEN AN ARTERIAL HIGHWAY COINCIDES WITH AN ADOPTED ROUTE FOR AN ADDITIONAL PUBLIC FACILITY (I.E., PEDESTRIAN, BICYCLE, OR EQUESTRIAN TRAIL), OR FOR A SCENIC HIGHWAY.
- 2.) THICKNESS OF PAVEMENT SECTION TO BE DETERMINED BY R-VALUE TESTING PER CALTRANS DESIGN METHOD TEST 301 WITH RECOMMENDED SAFETY FACTOR, MINIMUM 0.45' AC / 0.75' CAB\*. R-VALUE = 50 MAXIMUM. AC SHALL BE PLACED IN LIFTS, AND THICKNESS OF EACH LIFT SHALL NOT EXCEED 3".
- 3.) MINIMUM TI = 9, TRUCK ROUTES SHALL BE 12.
- 4.) HALF WIDTH STREETS SHALL BE CONSTRUCTED TO A WIDTH OF 1/2 STREET WIDTH PLUS 12' OR 18' ( WITH DEDICATED TURN LANES).
- 5.) ALTERNATE MINOR ARTERIAL WILL USED ONLY IN THE FOLLOWING CIRCUMSTANCES:
  - a.) SPECIFIC PLANS OR OTHER LARGE RESIDENTIAL, INDUSTRIAL, OR COMMERCIAL DEVELOPMENT WHERE ADDITIONAL RIGHT-OF-WAY CAN BE ACCOMMODATED OVER THE BREADTH OF A LARGE AREA, CAUSING LESS CONFLICT WITH MINIMUM LOT SIZE OR OTHER DEVELOPMENT REQUIREMENTS.
  - b.) WHERE CONFLICTS WITH UTILITIES EXIST (E.G., THE 30" HIGH PRESSURE GAS MAIN RUNNING ALONG THE NORTH SIDE OF COTTONWOOD AV; THE HIGHGROVE HIGH VOLTAGE TRANSMISSION LINE RUNNING DOWN PIGEON PASS RD/FREDERICK ST.)
  - c.) WHERE PARKWAYS MUST BE EXPANDED TO ALLOW FOR ADDITIONAL PUBLIC FACILITIES.

\* MINIMUM 0.67' AC / 1.00' CAB ON STREETS DESIGNATED AS TRUCK ROUTES

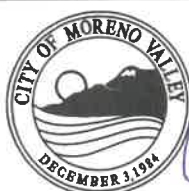
NOT TO SCALE

	RECOMMENDED: <i>Wei Sun</i> 2/1/2022 <small>DIVISION MANAGER / DATE</small>	<b>CITY OF MORENO VALLEY</b> PUBLIC WORKS DEPARTMENT - TRANSPORTATION ENGINEERING DIVISION	<small>STANDARD PLAN</small>
	APPROVED:  2/4/22 <small>PUBLIC WORKS DIRECTOR / DATE</small> <small>CITY ENGINEER</small>	<b>ALTERNATE MINOR ARTERIAL</b>	<b>MVSI-105B-1</b>



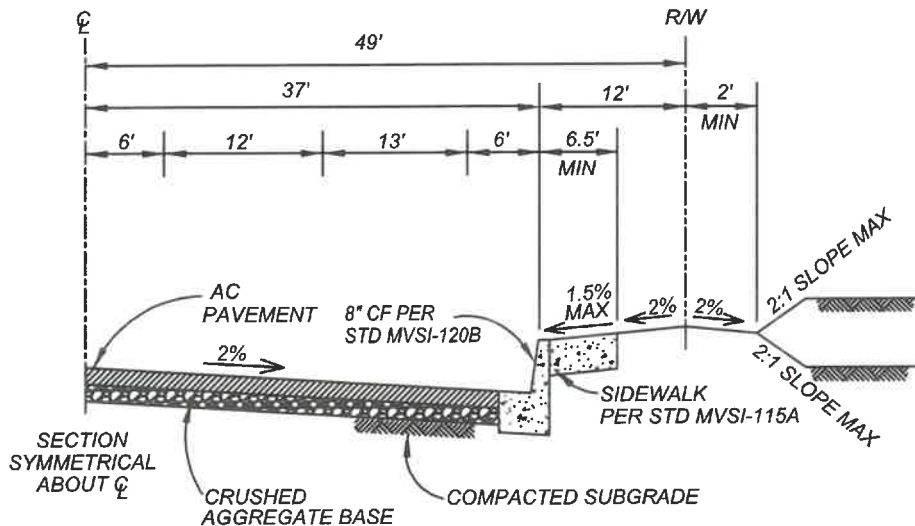

**TYPICAL SECTION**

**NOTES:**

- 1.) ADDITIONAL RIGHT-OF-WAY MAY BE REQUIRED WHEN AN ARTERIAL HIGHWAY COINCIDES WITH AN ADOPTED ROUTE FOR AN ADDITIONAL PUBLIC FACILITY (I.E., PEDESTRIAN, BICYCLE, OR EQUESTRIAN TRAIL), OR FOR A SCENIC HIGHWAY.
- 2.) THICKNESS OF PAVEMENT SECTION TO BE DETERMINED BY R-VALUE TESTING PER CALTRANS DESIGN METHOD TEST 301 WITH RECOMMENDED SAFETY FACTOR, MINIMUM 0.45' AC / 0.75' CAB\*. R-VALUE = 50 MAXIMUM. AC SHALL BE PLACED IN LIFTS, AND THICKNESS OF EACH LIFT SHALL NOT EXCEED 3".
- 3.) MINIMUM TI = 9, TRUCK ROUTES SHALL BE 12.
- 4.) HALF WIDTH STREETS SHALL BE CONSTRUCTED TO A WIDTH OF 1/2 STREET WIDTH PLUS 12' OR 18' ( WITH DEDICATED TURN LANES).
- 5.) LIMITS: IRONWOOD AV TO OLD LAKE DR.

\* MINIMUM 0.67' AC / 1.00' CAB ON STREETS DESIGNATED AS TRUCK ROUTES

NOT TO SCALE

	RECOMMENDED: <i>Wei Sun</i> 2/4/2022 DIVISION MANAGER / DATE	<b>CITY OF MORENO VALLEY</b> PUBLIC WORKS DEPARTMENT - TRANSPORTATION ENGINEERING DIVISION	STANDARD PLAN
	APPROVED: <i>[Signature]</i> 2/4/22 PUBLIC WORKS DIRECTOR / DATE CITY ENGINEER		<b>PIGEON PASS ROAD</b>

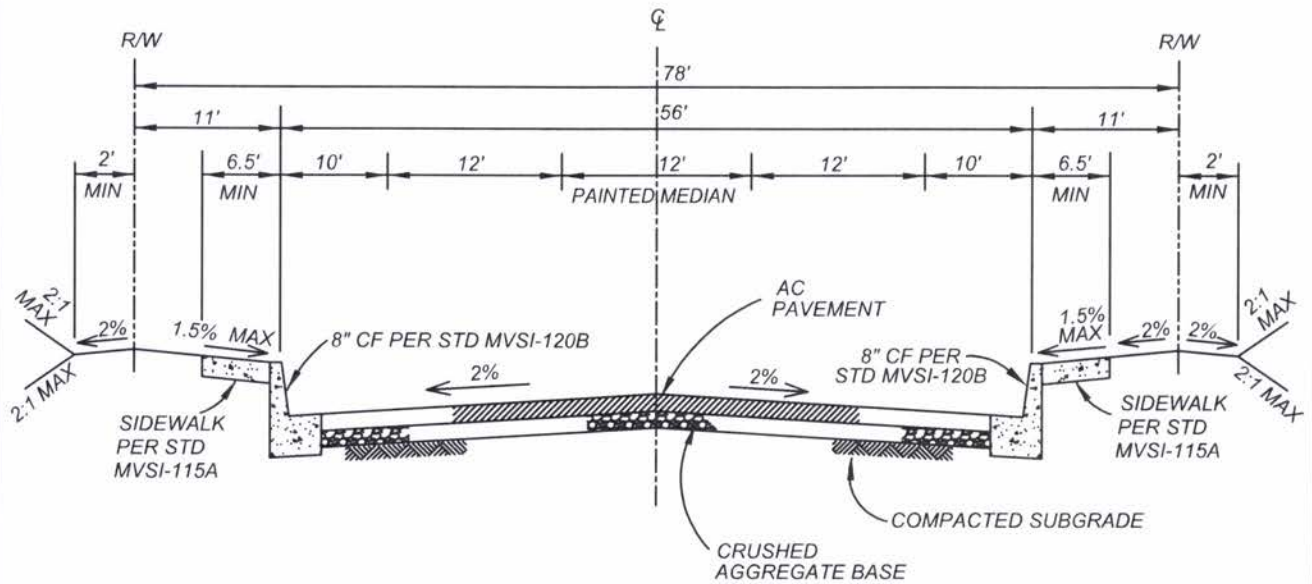

TYPICAL SECTION

**NOTES:**

- 1.) THICKNESS OF PAVEMENT SECTION TO BE DETERMINED BY R-VALUE TESTING PER CALTRANS DESIGN METHOD TEST 301 WITH RECOMMENDED SAFETY FACTOR, MINIMUM 0.50' AC / 1.00' CAB\*. R-VALUE = 50 MAXIMUM. AC SHALL BE PLACED IN LIFTS, AND THICKNESS OF EACH LIFT SHALL NOT EXCEED 3".
- 2.) MINIMUM TI = 10, TRUCK ROUTES SHALL BE 12.
- 3.) HALF WIDTH STREETS SHALL BE CONSTRUCTED TO A WIDTH OF 1/2 STREET WIDTH PLUS 18'.

\* MINIMUM 0.67' AC / 1.00' CAB ON STREETS DESIGNATED AS TRUCK ROUTES

NOT TO SCALE

	RECOMMENDED: <i>W. Sam</i> 10/31/23 PRINCIPAL ENGINEER / DATE	<b>CITY OF MORENO VALLEY</b> PUBLIC WORKS DEPARTMENT - TRANSPORTATION ENGINEERING DIVISION	
	APPROVED: <i>M. [Signature]</i> 10/31/23 PUBLIC WORKS DIRECTOR / DATE CITY ENGINEER	<b>INDUSTRIAL COLLECTOR</b>	

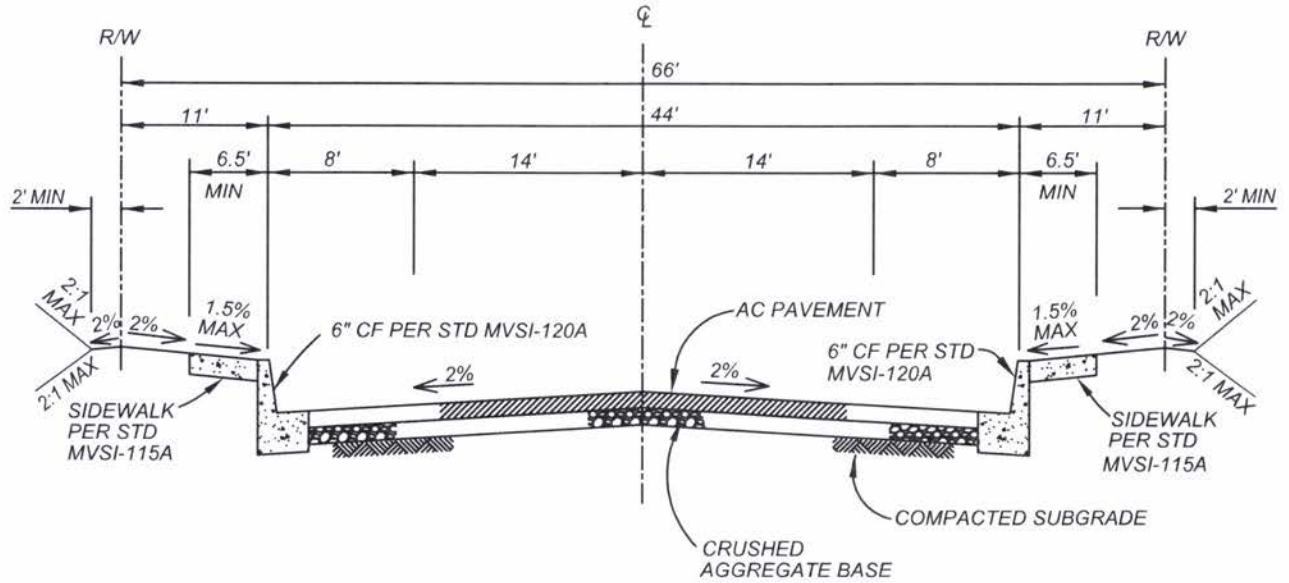

**TYPICAL SECTION**

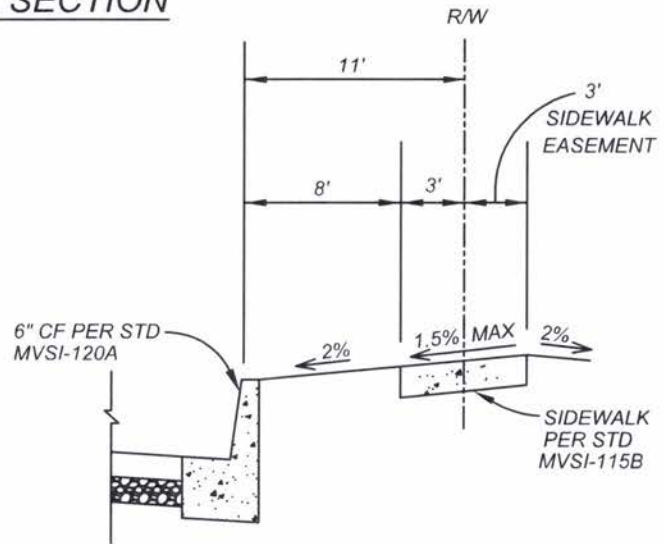

**ALTERNATE SECTION**

**NOTES:**

- 1.) THICKNESS OF PAVEMENT SECTION TO BE DETERMINED BY R VALUE TESTING PER CALTRANS DESIGN METHOD TEST 301 WITH RECOMMENDED SAFETY FACTOR, MINIMUM 0.30' AC / 0.50' CAB. AC SHALL BE PLACED IN LIFTS, AND THICKNESS OF EACH LIFT SHALL NOT EXCEED 3".
- 2.) MINIMUM T.I. = 7.
- 3.) HALF WIDTH STREETS SHALL BE CONSTRUCTED TO A WIDTH OF 1/2 STREET WIDTH PLUS 12'.

NOT TO SCALE

	RECOMMENDED: <i>Wei Sun</i> 10/31/23 PRINCIPAL ENGINEER / DATE	<b>CITY OF MORENO VALLEY</b> PUBLIC WORKS DEPARTMENT - TRANSPORTATION ENGINEERING DIVISION	
	APPROVED: <i>William Walker</i> 10/31/23 PUBLIC WORKS DIRECTOR / DATE CITY ENGINEER	<b>COLLECTOR</b>	

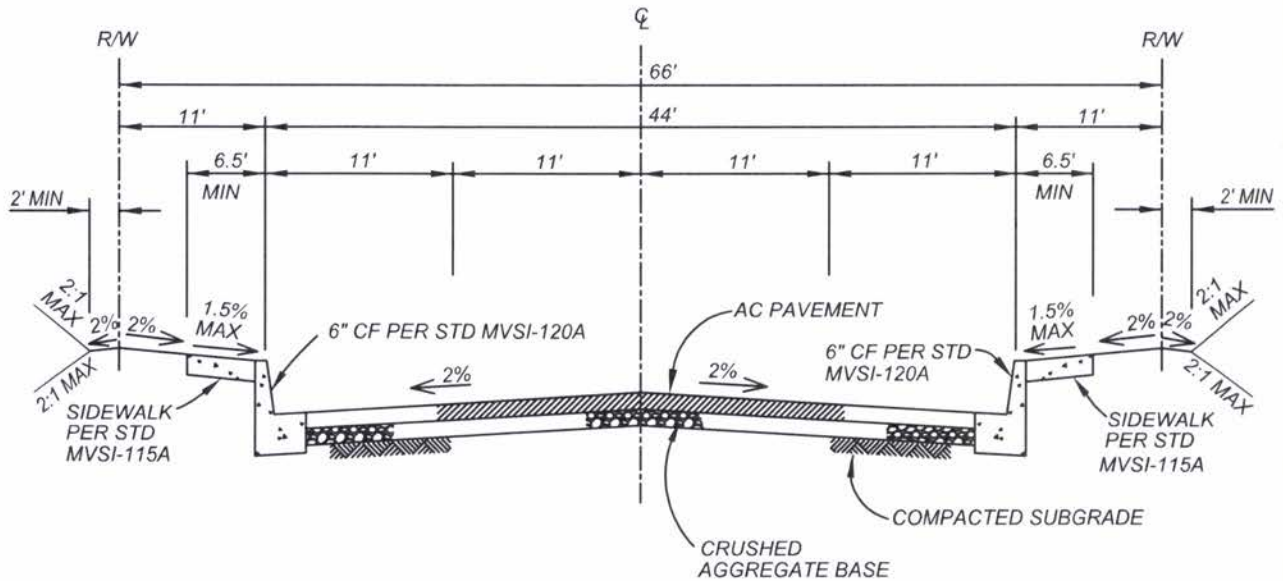

TYPICAL SECTION

**NOTES:**

- 1.) THICKNESS OF PAVEMENT SECTION TO BE DETERMINED BY R VALUE TESTING PER CALTRANS DESIGN METHOD TEST 301 WITH RECOMMENDED SAFETY FACTOR, MINIMUM 0.50' AC / 1.00' CAB. AC SHALL BE PLACED IN LIFTS, AND THICKNESS OF EACH LIFT SHALL NOT EXCEED 3".
- 2.) MINIMUM TI = 10.
- 3.) HALF WIDTH STREETS SHALL BE CONSTRUCTED TO A WIDTH OF 1/2 STREET WIDTH PLUS 12'.

NOT TO SCALE

	RECOMMENDED: <i>W. Sam</i> 10/31/23 PRINCIPAL ENGINEER / DATE	<b>CITY OF MORENO VALLEY</b> PUBLIC WORKS DEPARTMENT - TRANSPORTATION ENGINEERING DIVISION		
	APPROVED: <i>[Signature]</i> 10/31/23 PUBLIC WORKS DIRECTOR / DATE CITY ENGINEER	<b>NEIGHBORHOOD COLLECTOR</b>		STANDARD PLAN <b>MVSI-106C-0</b>
				SHEET 3 OF 3

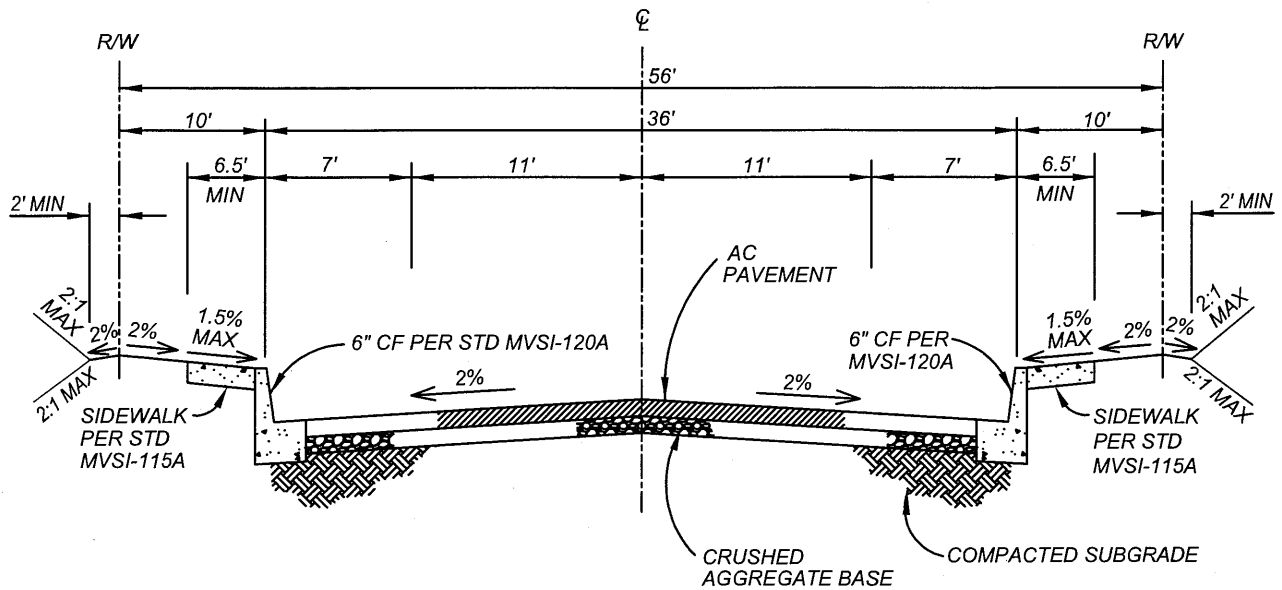

**TYPICAL SECTION**

**NOTES:**

- 1.) THICKNESS OF PAVEMENT SECTION TO BE DETERMINED BY R VALUE TESTING PER CALTRANS DESIGN METHOD TEST 301 WITH RECOMMENDED SAFETY FACTOR, MINIMUM 0.30' AC / 0.50' CAB. AC SHALL BE PLACED IN LIFTS, AND THICKNESS OF EACH LIFT SHALL NOT EXCEED 3".
- 2.) MINIMUM T.I. = 6.
- 3.) HALF WIDTH STREETS SHALL BE CONSTRUCTED TO A WIDTH OF 1/2 STREET WIDTH PLUS 12'.
- 4.) ALLOWED IN R2 AND R3 ZONING DISTRICTS.

NOT TO SCALE

	RECOMMENDED: <b>EL</b> <b>8/29/18</b> <small>DIVISION MANAGER      DATE</small>	<h2 style="margin: 0;">CITY OF MORENO VALLEY</h2> <p style="margin: 0;">PUBLIC WORKS DEPARTMENT - TRANSPORTATION ENGINEERING DIVISION</p>	
	APPROVED: <b>M.L. Worp</b> <b>9/14/18</b> <small>PUBLIC WORKS DIRECTOR / DATE</small> <small>CITY ENGINEER</small>	<h3 style="margin: 0;">LOCAL STREET</h3>	



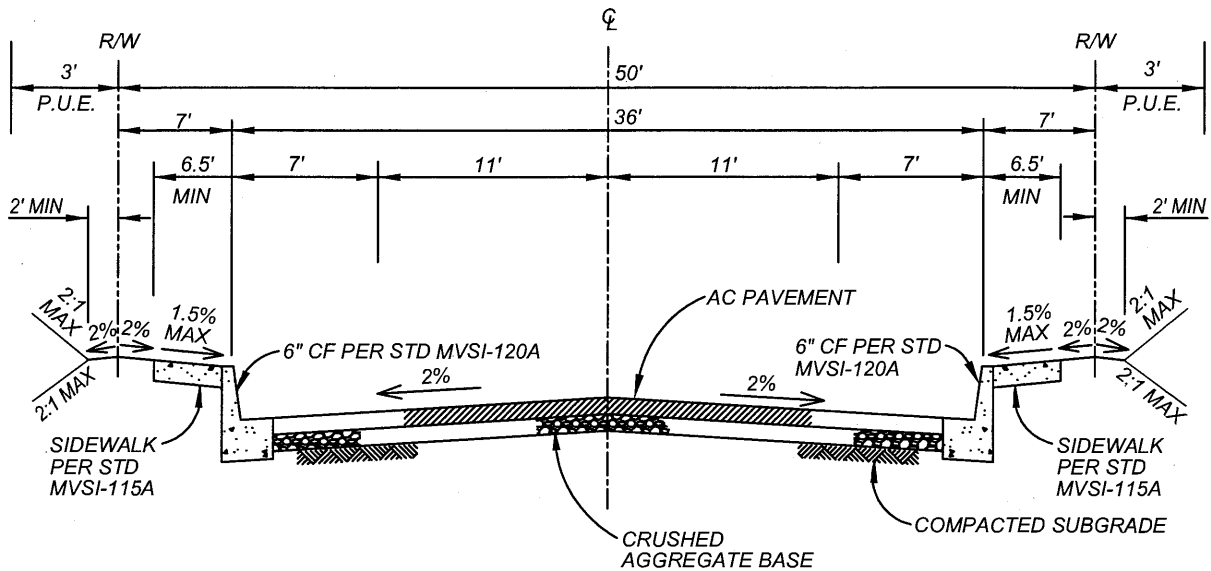



**TYPICAL SECTION**

**NOTES:**

- 1.) THICKNESS OF PAVEMENT SECTION TO BE DETERMINED BY R VALUE TESTING PER CALTRANS DESIGN METHOD TEST 301 WITH RECOMMENDED SAFETY FACTOR, MINIMUM 0.30' AC / 0.50' CAB. AC SHALL BE PLACED IN LIFTS AND THICKNESS OF EACH LIFT SHALL NOT EXCEED 3".
- 2.) MINIMUM T.I. = 6.
- 3.) HALF WIDTH STREETS SHALL BE CONSTRUCTED TO A WIDTH OF 1/2 STREET WIDTH PLUS 12'.
- 4.) MODIFIED LOCAL STREET MAY ONLY BE USED FOR CUL-DE-SAC STREET WITH 10 OR LESS LOTS.
- 5.) MODIFIED LOCAL STREETS MAY ONLY BE USED ON A CASE-BY-CASE BASIS AFTER REVIEW AND APPROVAL BY THE CITY ENGINEER.
- 6.) P.U.E. - PUBLIC UTILITY EASEMENT
- 7.) THIS STANDARD WILL NOT BE USED FOR NEW DEVELOPMENT PROJECTS, SEE NOTE NUMBER 5.

NOT TO SCALE

	RECOMMENDED: <b>EL</b> 8/27/18 <small>DIVISION MANAGER      DATE</small>	<h2 style="margin: 0;">CITY OF MORENO VALLEY</h2> <p style="margin: 0;">PUBLIC WORKS DEPARTMENT - TRANSPORTATION ENGINEERING DIVISION</p>	
	APPROVED:  9/12/18 <small>PUBLIC WORKS DIRECTOR / DATE</small> <small>CITY ENGINEER</small>	<h3 style="margin: 0;">MODIFIED LOCAL STREET</h3> <p style="margin: 0;">(USE ONLY UPON APPROVAL BY THE CITY ENGINEER)</p>	

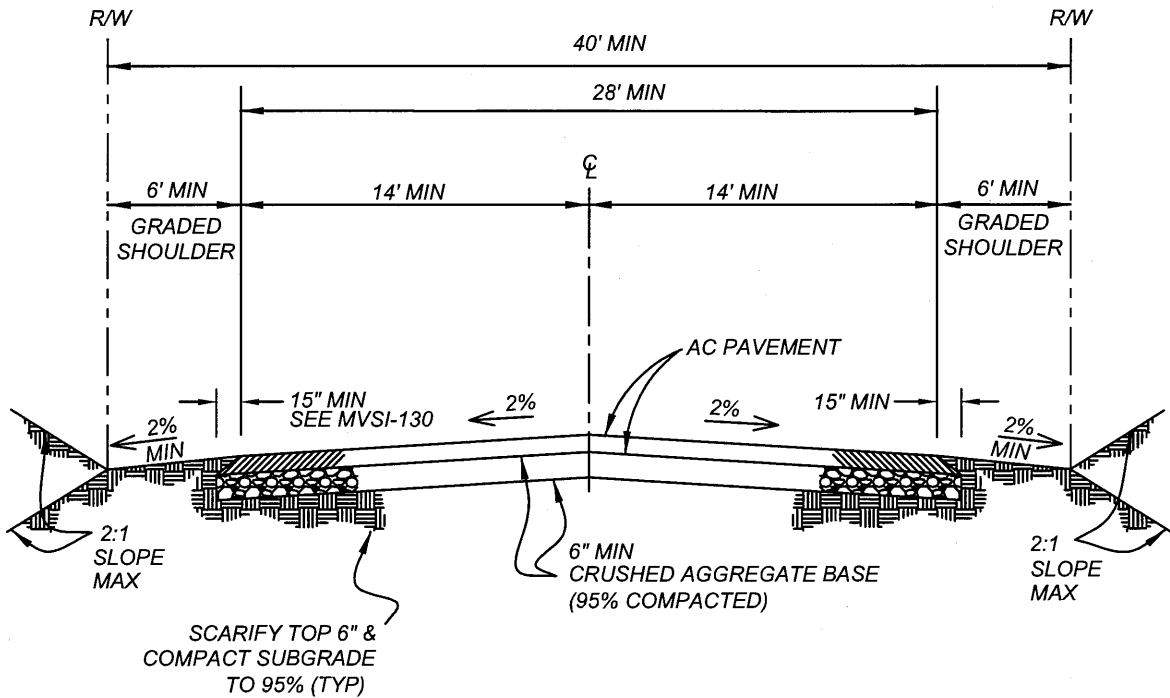

**NOTES:**

- 1.) DIMENSIONS AND STRUCTURAL SECTION SHOWN MAY REQUIRE ADJUSTMENT ACCORDING TO ACTUAL CONDITIONS INCLUDING, BUT NOT LIMITED TO, DRAINAGE, SOILS, ENVIRONMENTAL, SIGHT DISTANCE, EXISTING UTILITIES, ETC..
- 2.) THICKNESS OF PAVEMENT SECTION TO BE DETERMINED BY R VALUE TESTING PER CALTRANS DESIGN METHOD TEST 301 WITH RECOMMENDED SAFETY FACTOR, MINIMUM 0.30' AC / 0.50' CAB. AC SHALL BE PLACED IN LIFTS, AND THICKNESS OF EACH LIFT SHALL NOT EXCEED 3".
- 3.) RIGHT-OF-WAY DEDICATION MAY BE REQUIRED BY SEPARATE INSTRUMENT.
- 4.) MINIMUM LONGITUDINAL GRADE SHALL BE 1% OR AS APPROVED BY THE CITY ENGINEER.
- 5.) APPLICATION OF THIS STANDARD SUBJECT TO REVIEW AND APPROVAL BY THE CITY ENGINEER. (SITE CONDITION WILL DICTATE THE APPLICABILITY OF THIS STANDARD)
- 6.) GRADE SHOULDER AS NEEDED TO ACCOMMODATE DRAINAGE.
- 7.) EDGE OF PAVEMENT SHALL BE TAPERED PER CITY STD MVS-130.
- 8.) FOR USE IN HR AND RR ZONING DISTRICTS ONLY.
- 9.) ALL NATURAL VEGETATED SWALES WHERE FEASIBLE.

NOT TO SCALE

	RECOMMENDED: <div style="display: flex; justify-content: space-between; align-items: center;"> <span style="font-size: 1.5em; font-weight: bold;">EL</span> <span style="font-size: 1.5em; font-weight: bold;">12/18/17</span> </div> DIVISION MANAGER      DATE	<h2 style="margin: 0;">CITY OF MORENO VALLEY</h2> <p style="margin: 0;">PUBLIC WORKS DEPARTMENT - TRANSPORTATION ENGINEERING DIVISION</p>		
	APPROVED: <div style="display: flex; justify-content: space-between; align-items: center;"> <span style="font-size: 1.5em; font-weight: bold;">M.L. Worp</span> <span style="font-size: 1.5em; font-weight: bold;">9/4/18</span> </div> PUBLIC WORKS DIRECTOR / DATE CITY ENGINEER	<h3 style="margin: 0;">RURAL STREET</h3>		STANDARD PLAN <h3 style="margin: 0;">MVS-107C-0</h3>
			SHEET 3 OF 4	

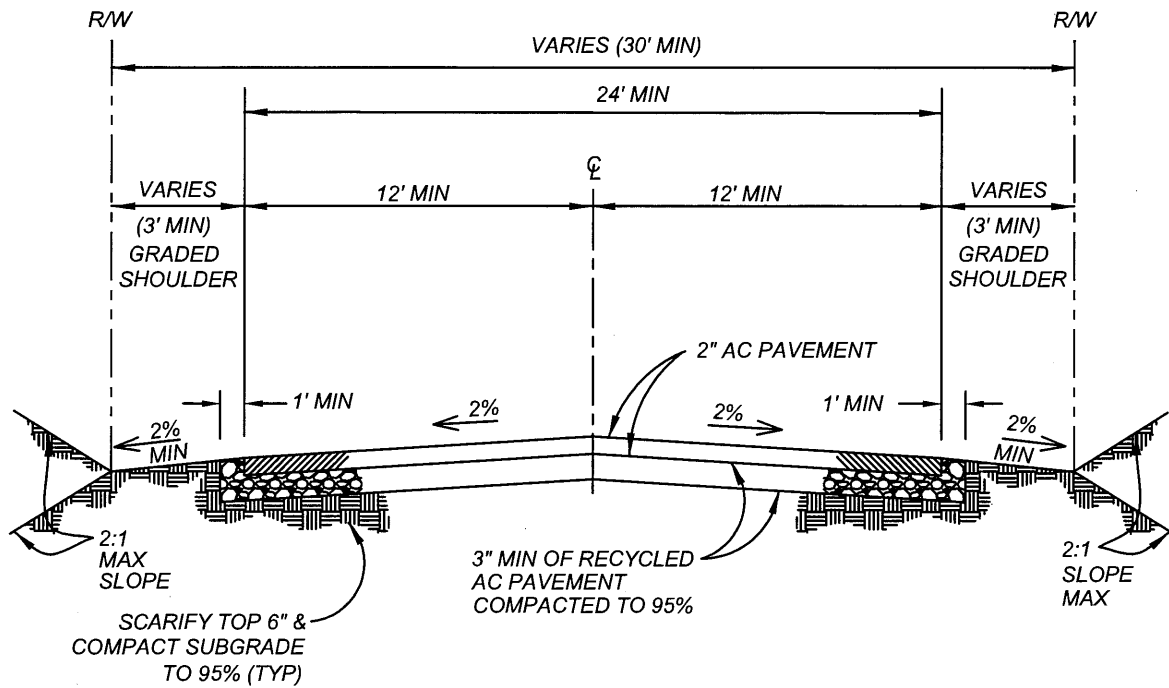



## TYPICAL SECTION

### **NOTES:**

- 1.) APPLICATION OF THIS STANDARD IS SUBJECT TO REVIEW AND APPROVAL BY THE CITY ENGINEER. DIMENSIONS AND STRUCTURAL SECTION SHOWN MAY REQUIRE ADJUSTMENT ACCORDING TO ACTUAL SITE CONDITIONS INCLUDING, BUT NOT LIMITED TO, DRAINAGE, SOILS, ENVIRONMENTAL, R-VALUE, SIGHT DISTANCE, TRAFFIC INDEX, EXISTING UTILITIES, ETC.
- 2.) RIGHT-OF-WAY DEDICATION MAY BE REQUIRED BY SEPARATE INSTRUMENT.
- 3.) LONGITUDINAL GRADE SHALL BE 1% MINIMUM AND 12% MAX OR AS APPROVED BY THE CITY ENGINEER.
- 4.) GRADE SHOULDER AS NEEDED TO ACCOMMODATE DRAINAGE.
- 5.) RECYCLED ASPHALT TO BE ENRICHED WITH OIL AND REJUVENATORS & COMPACTED IN ONE LIFT.
- 6.) THIS STANDARD WILL NOT BE USED FOR NEW DEVELOPMENT TYPE PROJECTS.
- 7.) SURFACE MUST BE CAPABLE OF SUPPORTING A GVW OF 80,000 LBS.

NOT TO SCALE

	RECOMMENDED: <div style="text-align: center;">  </div>	<div style="text-align: center;">  </div>	<h1 style="margin: 0;">CITY OF MORENO VALLEY</h1> <p style="margin: 0;">PUBLIC WORKS DEPARTMENT - TRANSPORTATION ENGINEERING DIVISION</p>	
	DIVISION MANAGER APPROVED:	DATE DATE	<h2 style="margin: 0;">ALL WEATHER TRANSPORTATION SURFACE</h2>	
PUBLIC WORKS DIRECTOR / CITY ENGINEER		STANDARD PLAN <b>MVSI-107D-0</b>		
		SHEET 4 OF 4		



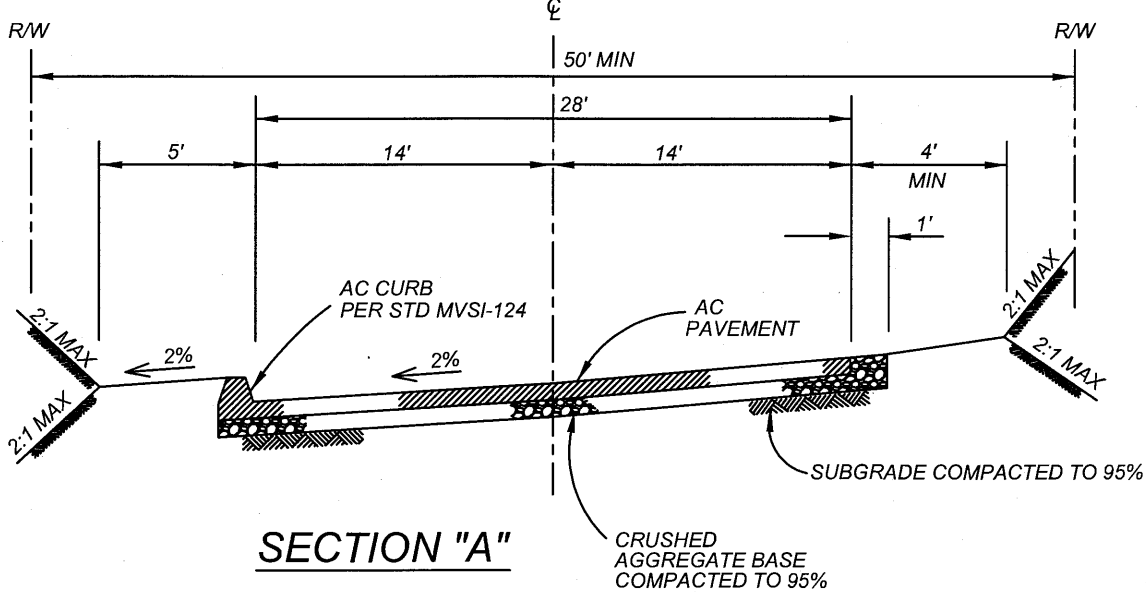
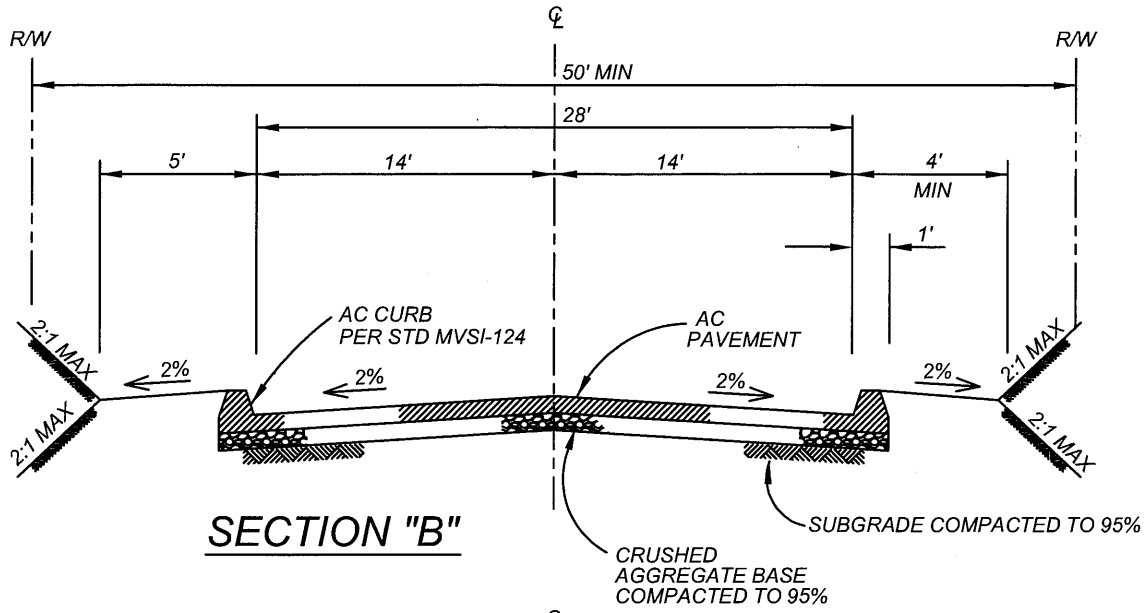

**NOTES:**

- 1.) DRAINAGE CONTROL TO BE APPROVED BY THE CITY ENGINEER. CONCRETE CURB AND/OR CURB AND GUTTER MAY BE REQUIRED.
- 2.) THICKNESS OF PAVEMENT SECTION TO BE DETERMINED BY R VALUE TESTING PER CALTRANS DESIGN METHOD TEST 301 WITH RECOMMENDED SAFETY FACTOR, MINIMUM 0.30' AC / 0.50' CAB. AC SHALL BE PLACED IN LIFTS, AND THICKNESS OF EACH LIFT SHALL NOT EXCEED 3".
- 3.) MINIMUM T.I. = 6.
- 4.) NO PARKING PERMITTED ON EITHER SIDE.

NOT TO SCALE

	RECOMMENDED: <b>EL</b> DIVISION MANAGER	<b>8/29/18</b> DATE	<h2 style="margin: 0;">CITY OF MORENO VALLEY</h2> <p style="margin: 0;">PUBLIC WORKS DEPARTMENT - TRANSPORTATION ENGINEERING DIVISION</p>	
	APPROVED: <b>M.L. Worp</b> PUBLIC WORKS DIRECTOR / DATE	<b>9/14/18</b> DATE CITY ENGINEER	<h3 style="margin: 0;">HILLSIDE RESIDENTIAL STREET</h3>	<b>MVSI-108A-0</b>
	STANDARD PLAN		SHEET 1 OF 2	

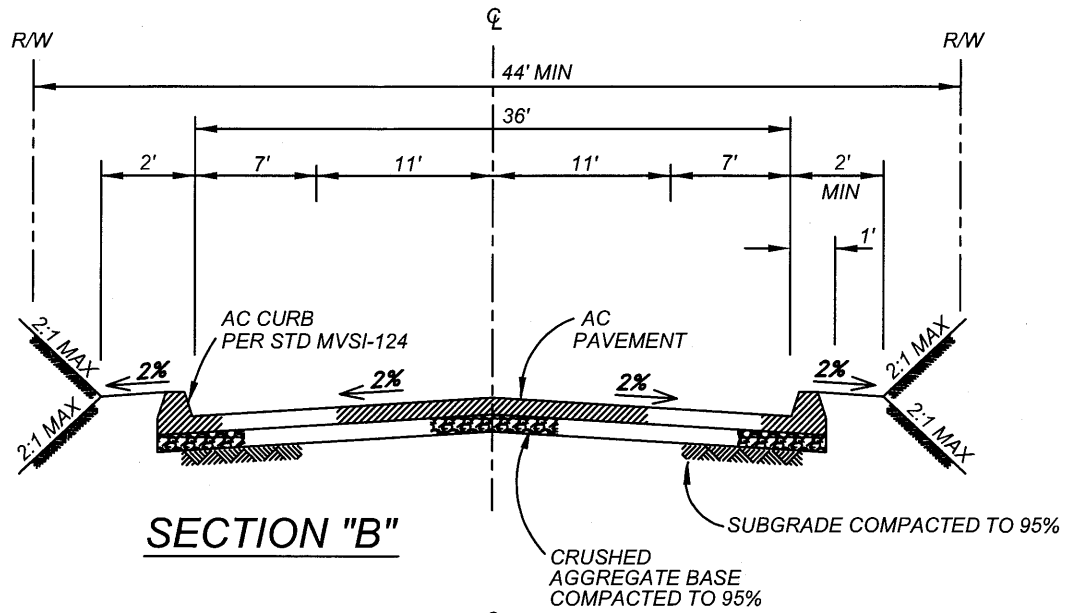

**SECTION "B"**

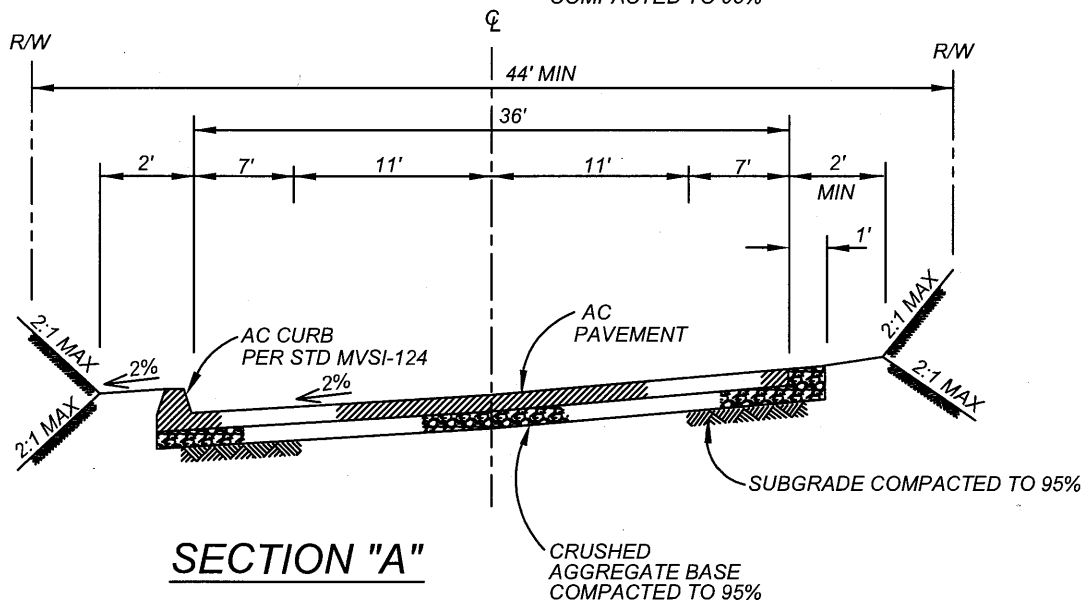

**SECTION "A"**

**NOTES:**

- 1.) DRAINAGE CONTROL TO BE APPROVED BY THE CITY ENGINEER. CONCRETE CURB AND/OR CURB AND GUTTER MAY BE REQUIRED.
- 2.) THICKNESS OF PAVEMENT SECTION TO BE DETERMINED BY R VALUE TESTING PER CALTRANS DESIGN METHOD TEST 301 WITH RECOMMENDED SAFETY FACTOR, MINIMUM 0.30' AC / 0.50' CAB. AC SHALL BE PLACED IN LIFTS, AND THICKNESS OF EACH LIFT SHALL NOT EXCEED 3".
- 3.) MINIMUM T.I. = 7.
- 4.) PARKING PERMITTED ON EITHER SIDE.

NOT TO SCALE

	RECOMMENDED: <b>EL</b> 8/29/18 <small>DIVISION MANAGER      DATE</small>	<h2 style="margin: 0;">CITY OF MORENO VALLEY</h2> <p style="margin: 0;">PUBLIC WORKS DEPARTMENT - TRANSPORTATION ENGINEERING DIVISION</p>	
	APPROVED:  9/14/18 <small>PUBLIC WORKS DIRECTOR / DATE</small> <small>CITY ENGINEER</small>	<h3 style="margin: 0;">HILLSIDE COLLECTOR STREET</h3>	
SHEET 2 OF 2			

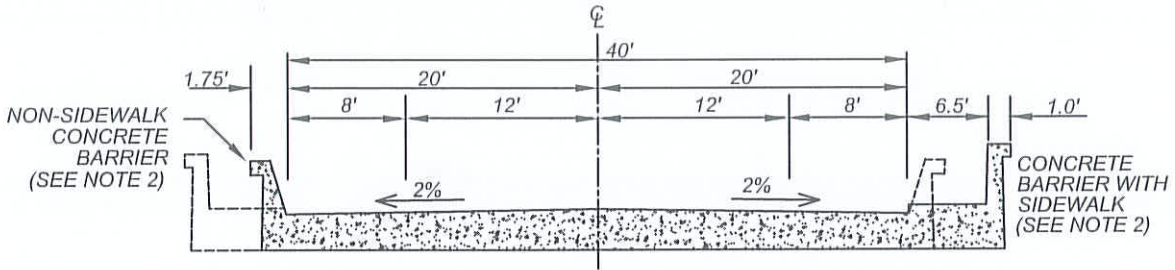

LOCAL STREET BRIDGE

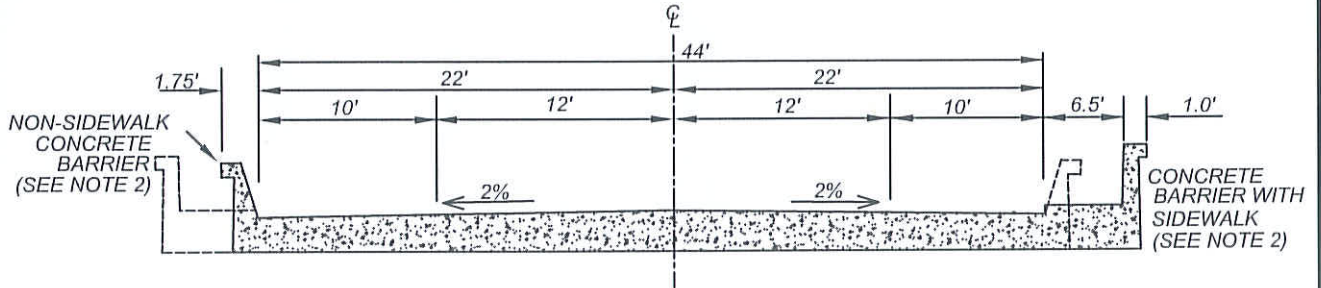

COLLECTOR STREET BRIDGE

**NOTES:**

- 1.) BRIDGE TYPE TO BE APPROVED BY CITY ENGINEER.
- 2.) RAISED SIDEWALK TO BE PROVIDED ON BOTH SIDES WHEN REQUIRED BY THE CITY ENGINEER. IF NOT REQUIRED, NON-SIDEWALK CONCRETE BARRIER SHALL BE USED.
- 3.) CONCRETE BARRIER SHALL BE TO CALTRANS STANDARDS OR AS APPROVED BY THE CITY ENGINEER.

NOT TO SCALE

	RECOMMENDED:  DIVISION MANAGER / DATE 1/21/14	<b>CITY OF MORENO VALLEY</b> PUBLIC WORKS DEPARTMENT - CAPITAL PROJECTS DIVISION	
	APPROVED:  PUBLIC WORKS DIRECTOR / CITY ENGINEER / DATE 1/29/14	<b>LOCAL AND COLLECTOR STREET BRIDGE</b>	

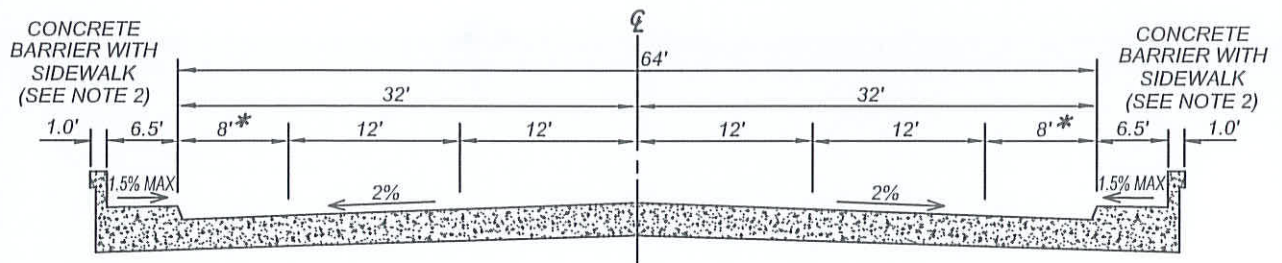

\*SUBJECT TO REVISION BY THE CITY ENGINEER

TYPICAL SECTION

**NOTES:**

- 1.) BRIDGE TYPE TO BE APPROVED BY CITY ENGINEER.
- 2.) RAISED SIDEWALK TO BE PROVIDED ON BOTH SIDES WHEN REQUIRED BY THE CITY ENGINEER. IF NOT REQUIRED, NON-SIDEWALK CONCRETE BARRIER SHALL BE USED.
- 3.) CONCRETE BARRIER SHALL BE TO CALTRANS STANDARDS OR AS APPROVED BY THE CITY ENGINEER.

NOT TO SCALE

	RECOMMENDED:  DIVISION MANAGER DATE: 1/21/14	<b>CITY OF MORENO VALLEY</b> PUBLIC WORKS DEPARTMENT - CAPITAL PROJECTS DIVISION		
	APPROVED:  PUBLIC WORKS DIRECTOR / CITY ENGINEER DATE: 1/29/14	<b>MINOR ARTERIAL BRIDGE</b>		STANDARD PLAN <b>MVSI-109B-0</b>
				SHEET 2 OF 3

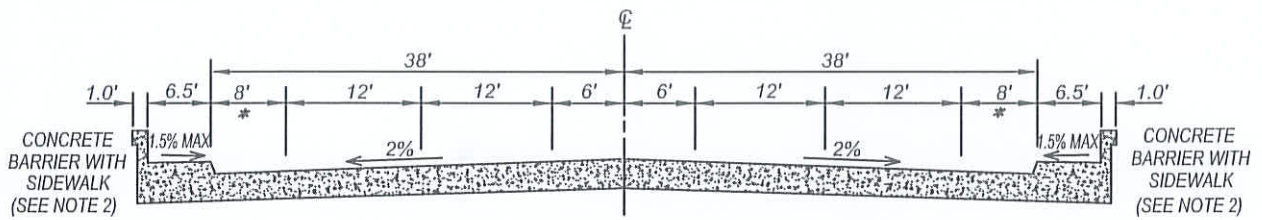



\*SUBJECT TO REVISION BY THE CITY ENGINEER

## TYPICAL SECTION

**NOTES:**

- 1.) BRIDGE TYPE TO BE APPROVED BY CITY ENGINEER.
- 2.) RAISED SIDEWALK TO BE PROVIDED ON BOTH SIDES WHEN REQUIRED BY THE CITY ENGINEER. IF NOT REQUIRED, NON-SIDEWALK CONCRETE BARRIER SHALL BE USED.
- 3.) CONCRETE BARRIER SHALL BE TO CALTRANS STANDARDS OR AS APPROVED BY CITY ENGINEER.

NOT TO SCALE

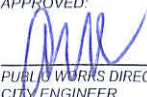
	RECOMMENDED:  DIVISION MANAGER      DATE 1/21/14	<h3 style="margin: 0;">CITY OF MORENO VALLEY</h3> <p style="margin: 0;">PUBLIC WORKS DEPARTMENT - CAPITAL PROJECTS DIVISION</p>	
	APPROVED:  PUBLIC WORKS DIRECTOR / CITY ENGINEER      DATE 1/29/14	<h3 style="margin: 0;">ARTERIAL BRIDGE</h3>	



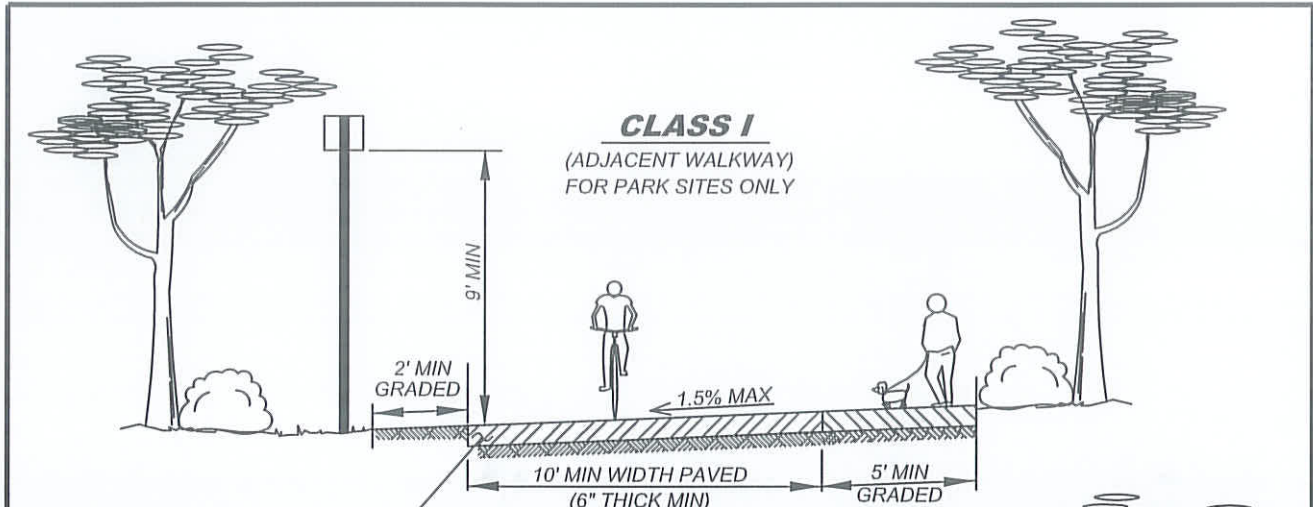

**CLASS I**  
(ADJACENT WALKWAY)  
FOR PARK SITES ONLY

3250 PSI CONCRETE PAVEMENT WITH 6"x6" WELDED WIRE MESH OVER 90% COMPACTED NATIVE, OR PERMEABLE CONCRETE PER GEOTECHNICAL ENGINEER'S RECOMMENDATIONS AND AS APPROVED BY THE ENGINEER.

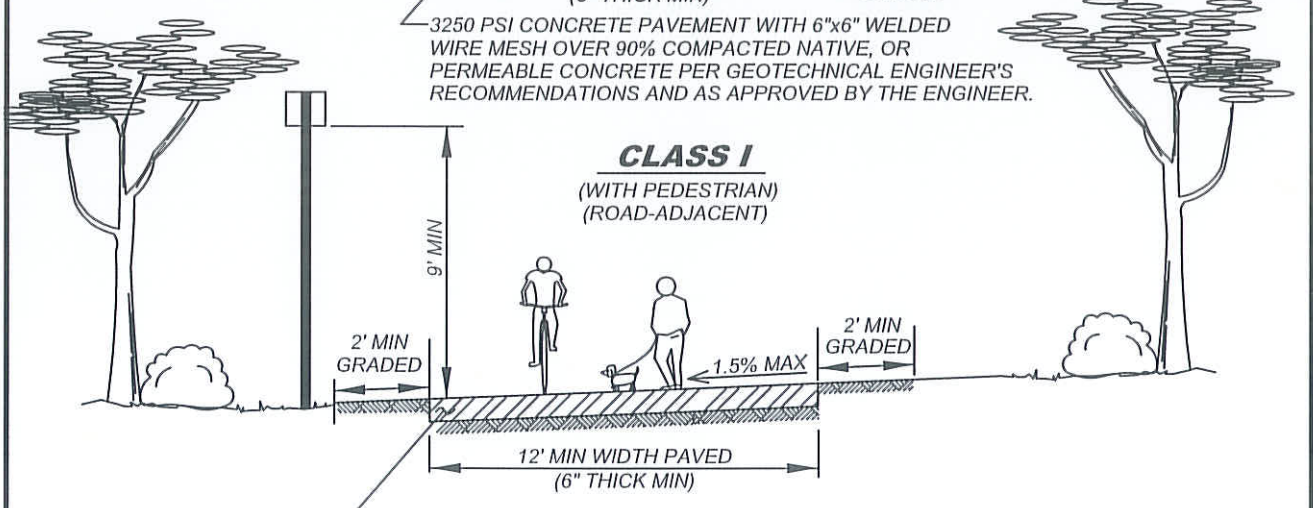

**CLASS I**  
(WITH PEDESTRIAN)  
(ROAD-ADJACENT)

3250 PSI CONCRETE PAVEMENT WITH 6"x6" WELDED WIRE MESH OVER 90% COMPACTED NATIVE, OR PERMEABLE CONCRETE PER GEOTECHNICAL ENGINEER'S RECOMMENDATIONS AND AS APPROVED BY THE ENGINEER.

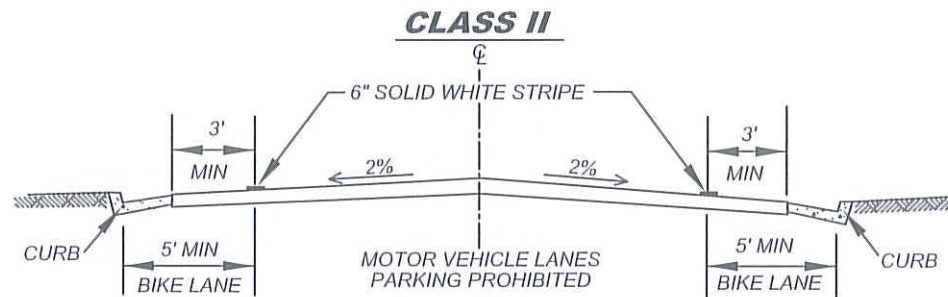



**CLASS II**

**NOTES:**

- 1.) CONCRETE MOW STRIP REQUIRED NEXT TO LANDSCAPE AREAS.
- 2.) CLASS I & II BIKE ROUTES TO BE STRIPED AND DESIGNATED WITH SIGNAGE.
- 3.) CLASS III BIKE ROUTES DESIGNATED WITH SIGNAGE AND/OR SHARROW MARKINGS.

NOT TO SCALE

	RECOMMENDED:  DIVISION MANAGER DATE: 1/21/14	<b>CITY OF MORENO VALLEY</b> PUBLIC WORKS DEPARTMENT - CAPITAL PROJECTS DIVISION	STANDARD PLAN <b>MVSI-110-0</b>
	APPROVED:  PUBLIC WORKS DIRECTOR / CITY ENGINEER DATE: 1/29/14	<b>TWO-WAY BIKE PATH ON SEPARATE RIGHT-OF-WAY</b>	SHEET 1 OF 1



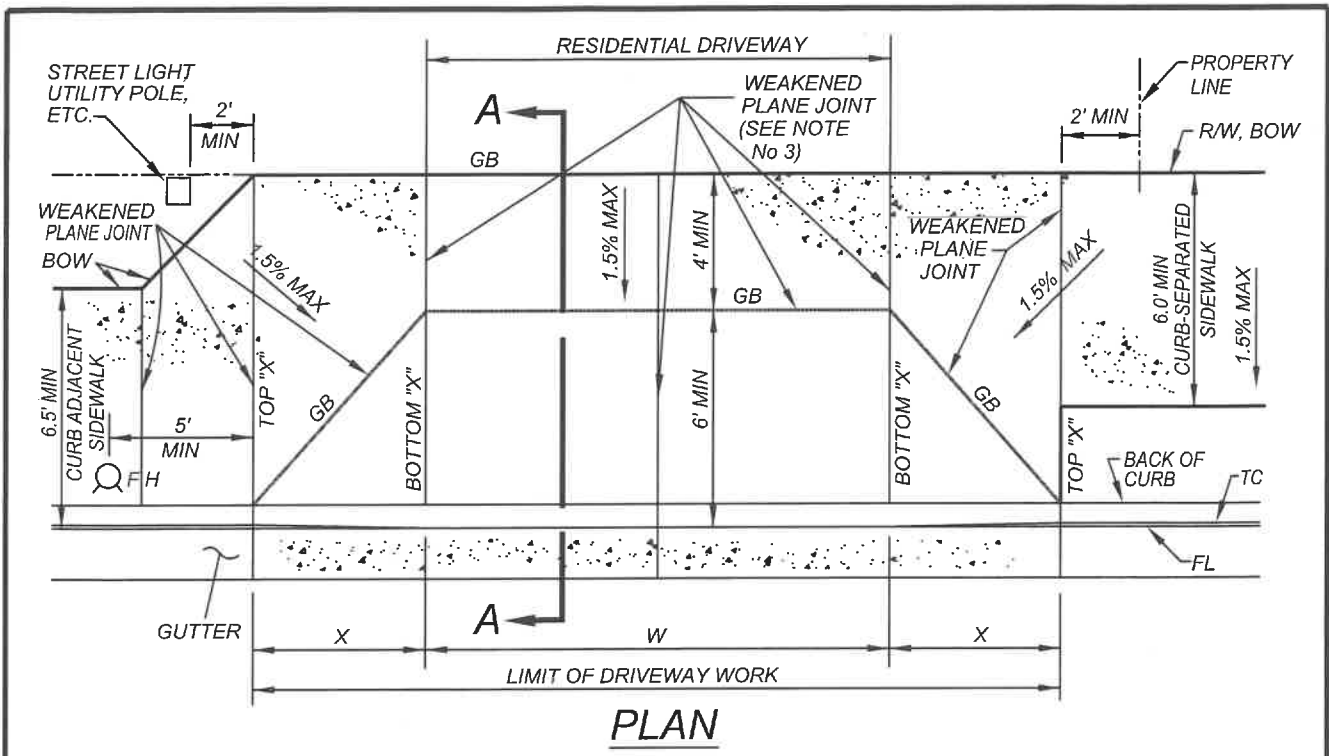

	6" CF	8" CF
X	4'	5'

W	MIN	MAX
	12'	30'

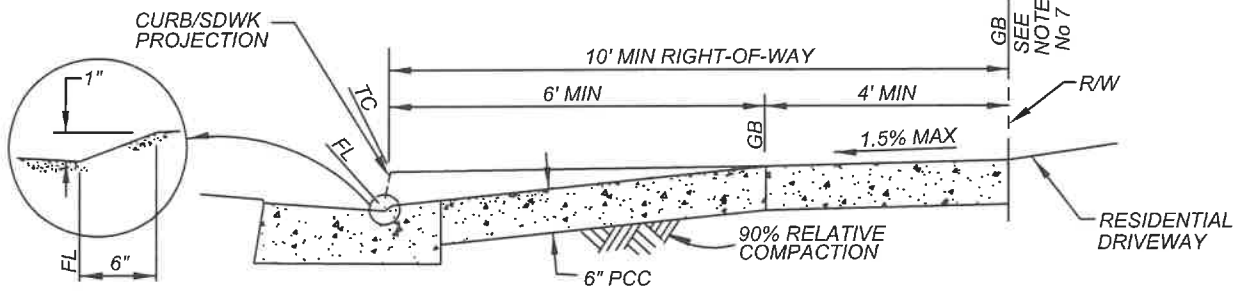

**SECTION "A-A"**

**NOTES:**

- 1.) ALL CONCRETE SHALL BE CLASS 560-C-3250, CURED WITH WHITE PIGMENTED CURING COMPOUND.
- 2.) ALL EXISTING PCC TO BE REMOVED SHALL BE SAWCUT AT THE JOINTS.
- 3.) DRIVEWAYS WITH  $14' \leq W \leq 20'$  SHALL HAVE A MINIMUM OF 1 WEAKENED PLANE JOINT AT  $\frac{1}{2}W$ . DRIVEWAYS WITH  $W > 20'$  SHALL HAVE WEAKENED PLANE JOINTS AT NOT TO EXCEED 5' ON CENTER. ALL DRIVEWAY WIDTHS SHALL HAVE WEAKENED PLANE LINES AT THE BOTTOM "X" LOCATION OF THE DRIVEWAY APPROACH TO CONTROL CRACKING.
- 4.) FOR CONSTRUCTING NEW DRIVEWAY APPROACHES ON EXISTING STREETS, A 12" WIDTH OF ASPHALT CONCRETE SHALL BE REMOVED AND REPLACED TO FULL DEPTH.
- 5.) DRIVEWAYS FOR CORNER LOTS SHALL BE LOCATED ADJACENT TO THE PROPERTY LINE AWAY FROM THE INTERSECTION.
- 6.) W DIMENSION SHALL MATCH WIDTH OF GARAGE(S) UNLESS OTHERWISE APPROVED BY THE CITY ENGINEER.
- 7.) 14% MAX. GRADE BREAK BETWEEN DRIVEWAY AND APPROACH.

NOT TO SCALE

	RECOMMENDED: <i>Henry</i> 7/16/19 DIVISION MANAGER DATE	<b>CITY OF MORENO VALLEY</b> PUBLIC WORKS DEPARTMENT - CAPITAL PROJECTS DIVISION	STANDARD PLAN <b>MVSI-111A-0</b>
	APPROVED: <i>M. Lopez</i> 7/16/19 PUBLIC WORKS DIRECTOR / DATE CITY ENGINEER	<b>RESIDENTIAL DRIVEWAY          APPROACH</b> (FOR RIGHT-OF-WAY WIDTH BEHIND CURB OF 10' OR MORE)	SHEET 1 OF 3

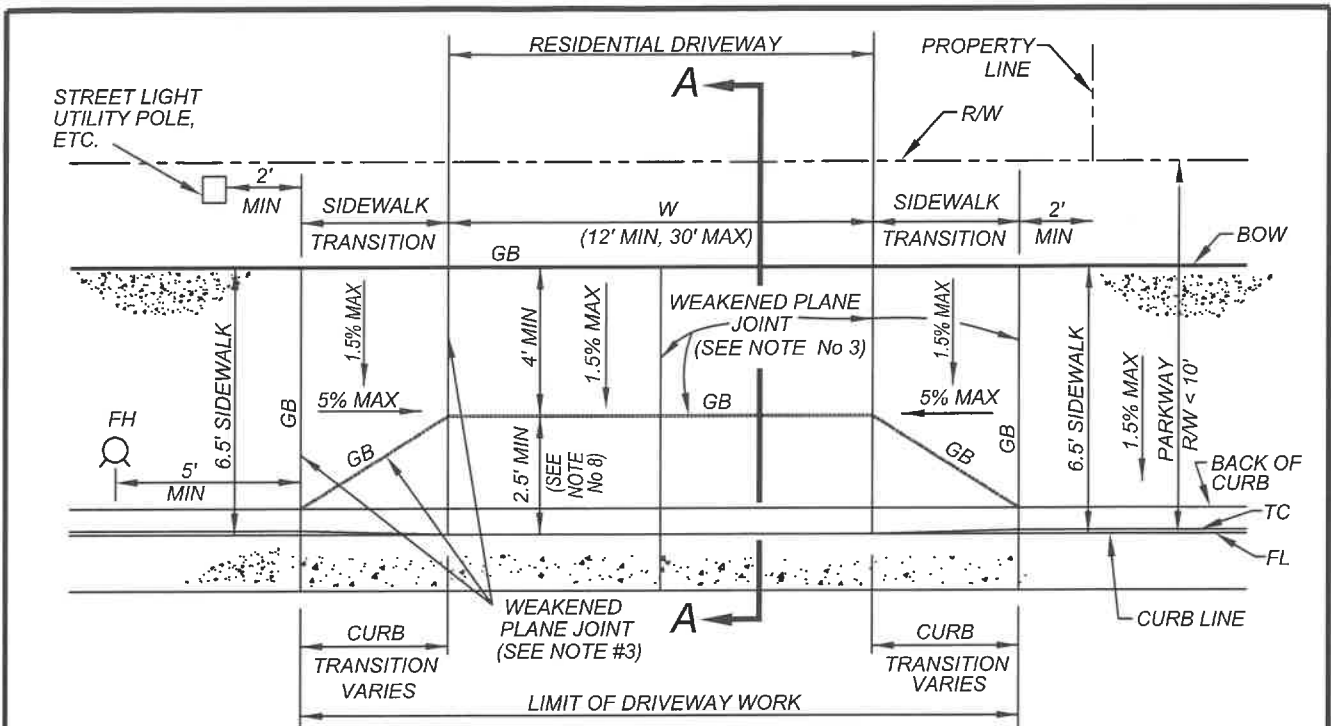

**PLAN**

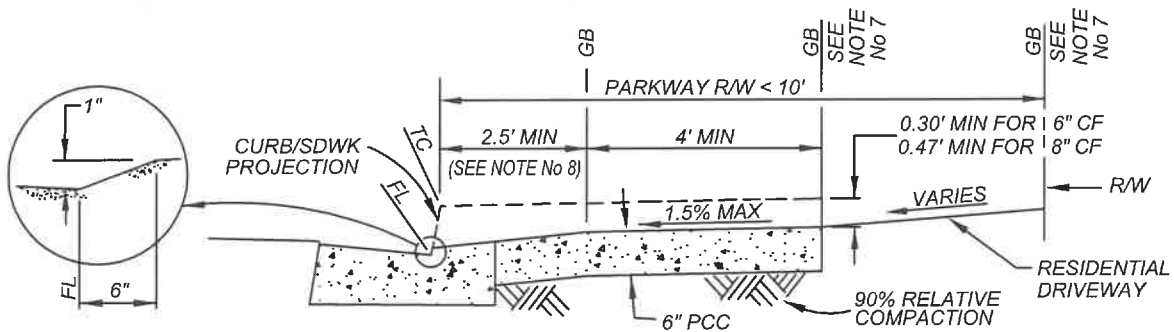

**SECTION "A-A"**

**NOTES:**

- 1.) ALL CONCRETE SHALL BE CLASS 560-C-3250, CURED WITH WHITE PIGMENTED CURING COMPOUND.
- 2.) ALL EXISTING PCC TO BE REMOVED SHALL BE SAW CUT AT THE JOINTS.
- 3.) DRIVEWAYS WITH  $14' \leq W \leq 20'$  SHALL HAVE A MINIMUM OF 1 WEAKENED PLANE JOINT AT  $\frac{1}{2}W$ . DRIVEWAYS WITH  $W > 20'$  SHALL HAVE WEAKENED PLANE JOINTS AT NOT TO EXCEED 5' ON CENTER. ALL DRIVEWAY WIDTHS SHALL HAVE WEAKENED PLANE JOINTS AT THE BOTH SIDES OF SIDEWALK TRANSITION SECTIONS OF THE DRIVEWAY APPROACH TO CONTROL CRACKING.
- 4.) FOR NEW DRIVEWAY APPROACHES ON EXISTING STREETS A 12" WIDTH OF ASPHALT CONCRETE SHALL BE REMOVED AND REPLACED TO FULL DEPTH.
- 5.) DRIVEWAYS FOR CORNER LOTS SHALL BE LOCATED ADJACENT TO THE PROPERTY LINE AWAY FROM THE INTERSECTION.
- 6.) W DIMENSION SHALL MATCH WIDTH OF GARAGE DOORS UNLESS OTHERWISE APPROVED BY THE CITY ENGINEER.
- 7.) 14% MAX GRADE BREAK BETWEEN DRIVEWAY AND APPROACH.
- 8.) THE SLOPED SECTION OF DRIVEWAY APPROACH SHOULD BE EXTENDED TO MINIMIZE THE STEEPNESS BY UTILIZING THE MAXIMUM AVAILABLE PARKWAY RIGHT-OF-WAY WIDTH.
- 9.) THIS STANDARD SHALL NOT BE USED FOR NEW DEVELOPMENT.

NOT TO SCALE

	RECOMMENDED: <i>Henrygo</i> 7/16/19 DIVISION MANAGER DATE	<b>CITY OF MORENO VALLEY</b> PUBLIC WORKS DEPARTMENT - CAPITAL PROJECTS DIVISION	
	APPROVED: <i>M. L. Wolfe</i> 10/16/19 PUBLIC WORKS DIRECTOR / DATE CITY ENGINEER	<b>RESIDENTIAL DRIVEWAY          APPROACH          (FOR CONFINED RIGHT-OF-WAY)</b>	

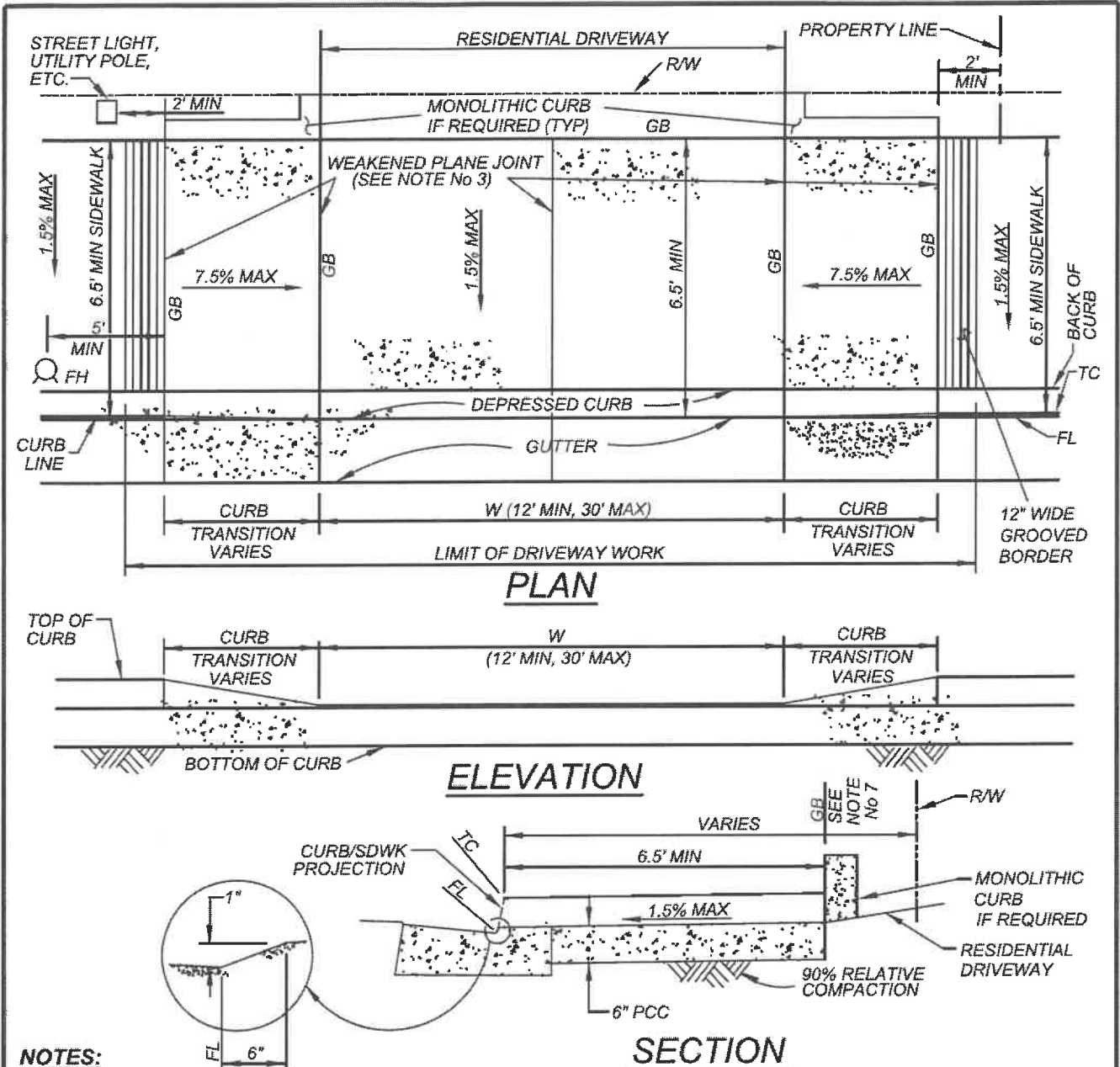

**NOTES:**

- 1.) ALL CONCRETE SHALL BE CLASS 560-C-3250, CURED WITH WHITE PIGMENTED CURING COMPOUND.
- 2.) ALL EXISTING PCC TO BE REMOVED SHALL BE SAWCUT AT THE JOINTS.
- 3.) DRIVEWAYS WITH  $14' \leq W \leq 20'$  SHALL HAVE A MINIMUM OF 1 WEAKENED PLANE JOINT AT  $\frac{1}{2}W$ . DRIVEWAYS WITH  $W > 20'$  SHALL HAVE WEAKENED PLANE JOINTS AT NOT TO EXCEED 5' ON CENTER. ALL DRIVEWAY WIDTHS SHALL HAVE WEAKENED PLANE LINES AT BOTH SIDES OF "CURB TRANSITIONS" SECTIONS OF THE DRIVEWAY APPROACH TO CONTROL CRACKING.
- 4.) FOR NEW DRIVEWAY APPROACHES ON EXISTING STREETS A 12" WIDTH OF ASPHALT CONCRETE SHALL BE REMOVED AND REPLACED TO FULL DEPTH.
- 5.) DRIVEWAYS FOR CORNER LOTS SHALL BE LOCATED ADJACENT TO THE PROPERTY LINE AWAY FROM THE INTERSECTION.
- 6.) W DIMENSION SHALL MATCH WIDTH OF GARAGE DOORS UNLESS OTHERWISE APPROVED BY THE CITY ENGINEER.
- 7.) 14% MAXIMUM GRADE BREAK BETWEEN DRIVEWAY AND APPROACH.

NOT TO SCALE

	RECOMMENDED: <i>Hanuygo</i> 7/16/19 DIVISION MANAGER DATE	<h2 style="margin: 0;">CITY OF MORENO VALLEY</h2> <p style="margin: 0;">PUBLIC WORKS DEPARTMENT - CAPITAL PROJECTS DIVISION</p>	STANDARD PLAN <b>MVSI-111C-1</b>
	APPROVED: <i>M. Lopez</i> 10/11/19 PUBLIC WORKS DIRECTOR / DATE CITY ENGINEER	<h3 style="margin: 0;">RESIDENTIAL DRIVEWAY APPROACH</h3> <p style="margin: 0;"><b>(FOR CONFINED RIGHT-OF-WAY)</b></p>	

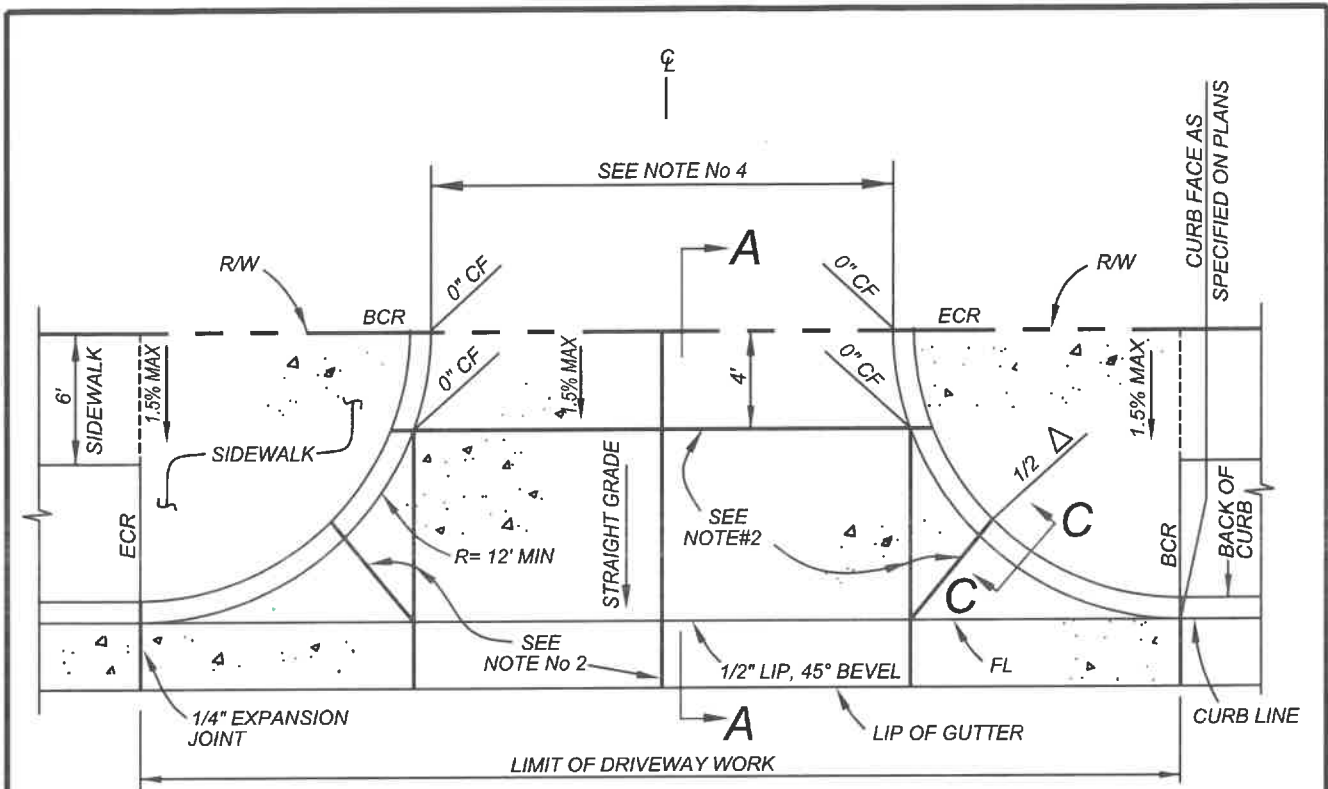

**PLAN VIEW**

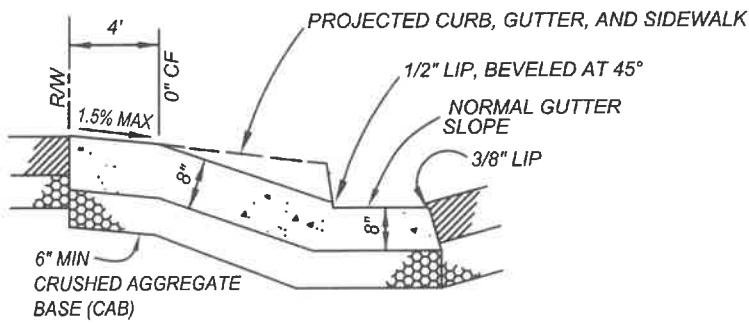

**SECTION A-A**

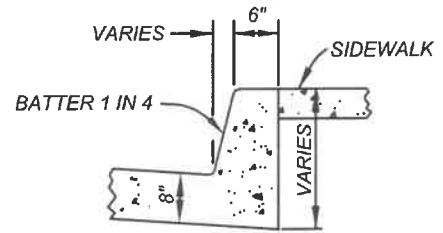

**SECTION C-C**

**NOTES:**

- 1.) TYPE I APPROACH MAY BE USED WHEN SIDEWALK IS ADJACENT TO PROPERTY LINE.
- 2.) WEAKENED PLANE JOINTS ARE REQUIRED AT CENTERLINE OF APPROACH AND AT LOCATIONS AS SHOWN, SPACED 10' MAXIMUM AND AS NECESSARY.
- 3.) CONCRETE SHALL BE CLASS 560-C-3250, CURED WITH WHITE PIGMENTED CURING COMPOUND.
- 4.) MINIMUM WIDTH SHALL BE 24', MAXIMUM WIDTH SHALL BE 40'.
- 5.) 4' LONG #4 SMOOTH ROUND BARS SHALL BE USED WHEN DRIVEWAY APPROACH IS NOT POURED MONOLITHICALLY.
- 6.) FOR NEW DRIVEWAY APPROACHES ON EXISTING STREETS A 12" WIDTH OF ASPHALT CONCRETE SHALL BE REMOVED AND REPLACED TO FULL DEPTH.

NOT TO SCALE

	RECOMMENDED: <i>Henrygo</i> 12/16/24 DIVISION MANAGER DATE	<h2 style="margin: 0;">CITY OF MORENO VALLEY</h2> <p style="margin: 0;">PUBLIC WORKS DEPARTMENT - CAPITAL PROJECTS DIVISION</p>	STANDARD PLAN <b>MVSI-112A-0</b>
	APPROVED: <i>[Signature]</i> 2/4/25 PUBLIC WORKS DIRECTOR / DATE CITY ENGINEER	<h3 style="margin: 0;">COMMERCIAL DRIVEWAY APPROACH: TYPE 1</h3> <p style="margin: 0;">(NOT TO BE USED FOR NEW DEVELOPMENT)</p>	

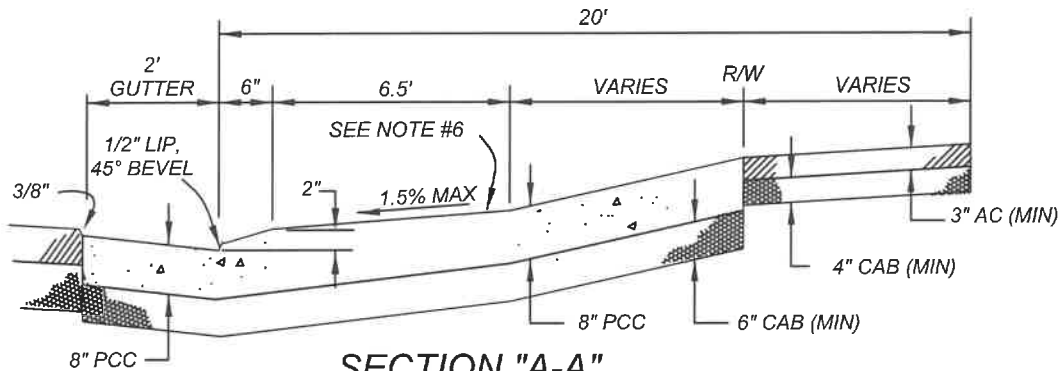
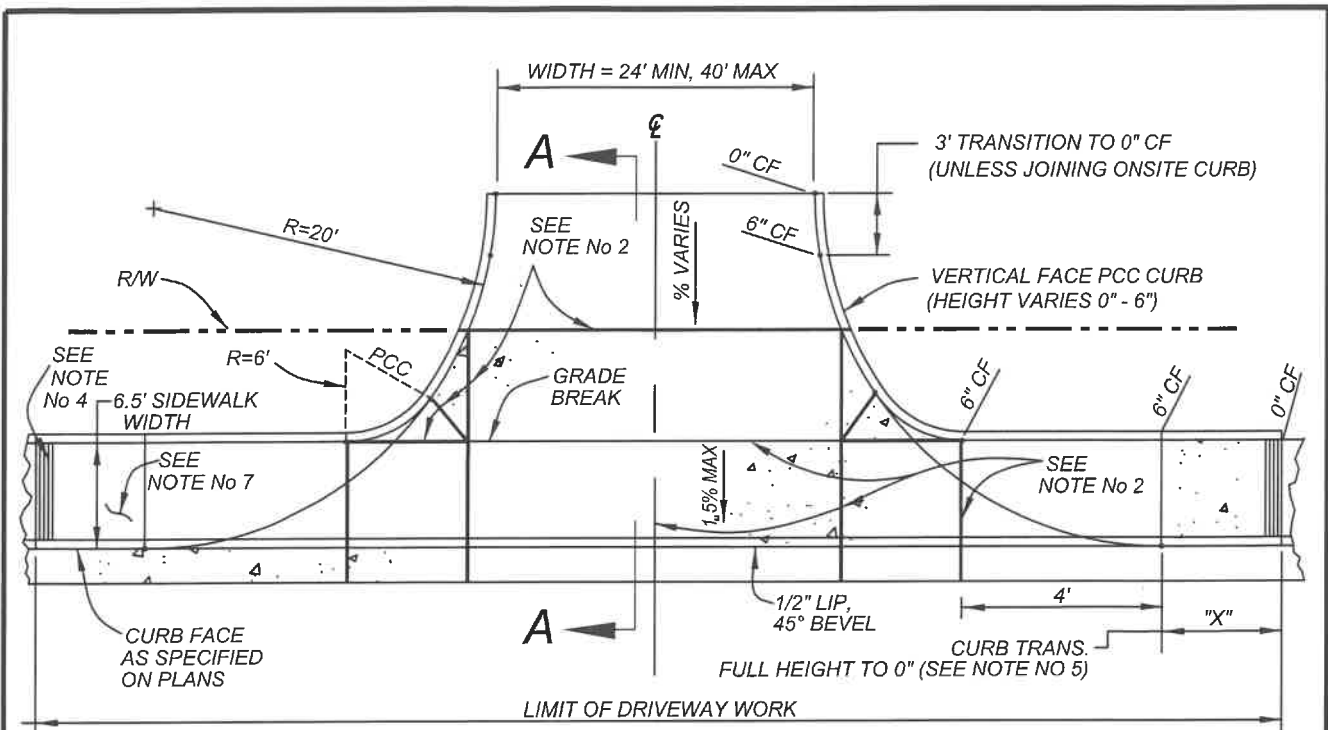

**SECTION "A-A"**

**NOTES:**

- 1.) TYPE II APPROACH SHALL BE USED INSTEAD OF TYPE III OR TYPE IV APPROACH FOR SITES REQUIRING SMALL SEMITRAILER (AASHTO DESIGN VEHICLE WB-40) ACCESS.
- 2.) WEAKENED PLANE JOINTS ARE REQUIRED AT CENTERLINE OF APPROACH AND AT LOCATIONS AS SHOWN, SPACED 10' MAX AND AS NECESSARY.
- 3.) CONCRETE SHALL BE CLASS 560-C-3250, CURED WITH WHITE PIGMENTED CURING COMPOUND.
- 4.) TOP OF SIDEWALK RAMP SHALL HAVE 12" WIDE BORDER WITH GROOVES 1/4" DEEP, WITH 1/8" RADIUS, AND SPACED AT 3/4" OC.
- 5.) "X" SHALL HAVE A MAXIMUM SLOPE OF 1:12 (8.33%), AND A MINIMUM SLOPE OF 1:15 (6.67%).
- 6.) RAMP SURFACE SHALL BE SLIP-RESISTANT AND SHALL BE OF CONTRASTING FINISH FROM ADJACENT SIDEWALK (ROUGH BROOM FINISH OR EQUIVALENT).
- 7.) ALL ACCESS RAMPS SHALL BE CONSTRUCTED TO THE MOST CURRENT REQUIREMENT OF THE AMERICANS WITH DISABILITIES ACT (ADA) STANDARDS/CALIFORNIA CODE OF REGULATIONS TITLE 24-ACCESSIBILITY REGULATIONS. ADJUSTMENTS SHALL BE MADE IN THE FIELD TO ACHIEVE RAMP CONDITIONS.
- 8.) 4' LONG #4 SMOOTH ROUND BARS SHALL BE USED WHEN DRIVEWAY APPROACH IS NOT POURED MONOLITHICALLY.

NOT TO SCALE

	RECOMMENDED: <i>Henry</i> 7/16/19 DIVISION MANAGER DATE	<h2 style="margin: 0;">CITY OF MORENO VALLEY</h2> <p style="margin: 0;">PUBLIC WORKS DEPARTMENT - CAPITAL PROJECTS DIVISION</p>
	APPROVED: <i>M.L. Wolf</i> 10/16/19 PUBLIC WORKS DIRECTOR / DATE CITY ENGINEER	<h3 style="margin: 0;">COMMERCIAL DRIVEWAY APPROACH: TYPE II</h3>

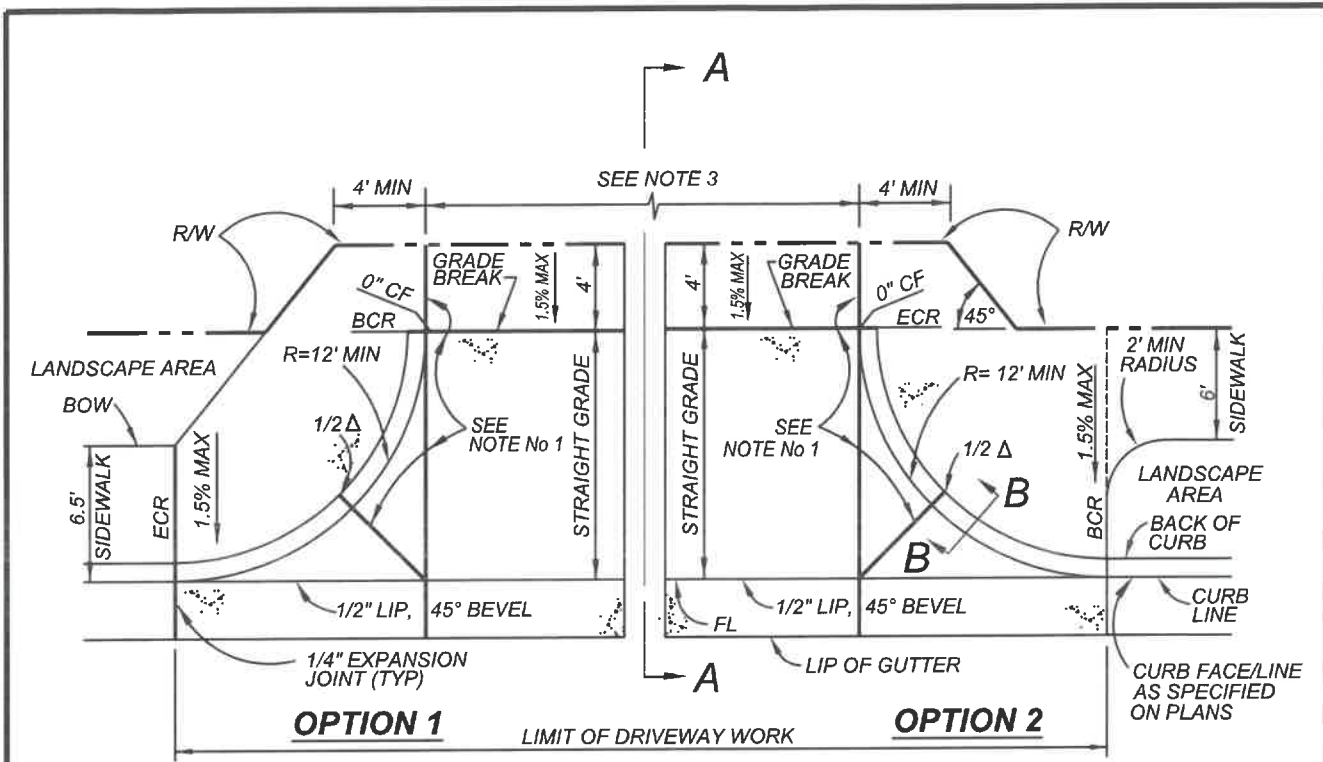

**PLAN VIEW**

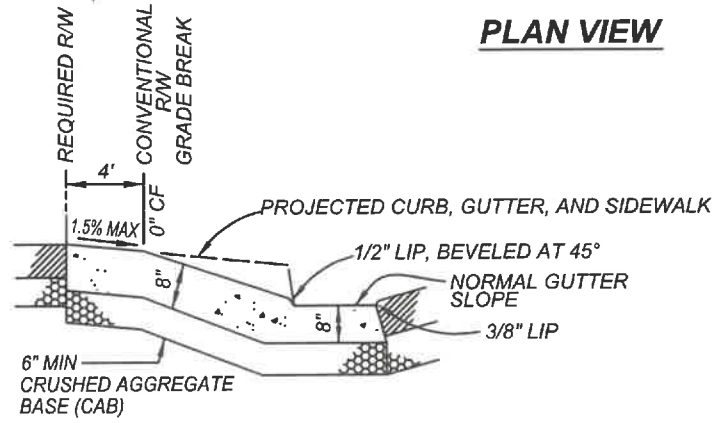

**SECTION A-A**

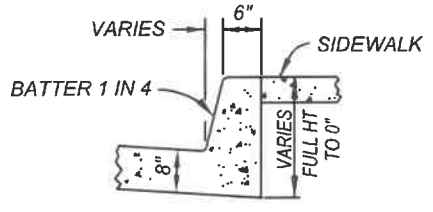

**SECTION B-B**

**NOTES:**

- 1.) WEAKENED PLANE JOINT REQUIRED AT CENTERLINE OF APPROACH AND AT LOCATIONS AS SHOWN, SPACED 10' MAX AS NECESSARY.
- 2.) CONCRETE SHALL BE CLASS 560-C-3250, CURED WITH WHITE PIGMENTED CURING COMPOUND.
- 3.) MINIMUM WIDTH SHALL BE 24', MAXIMUM WIDTH SHALL BE 40' FOR COMMERCIAL DEVELOPMENT. FOR INDUSTRIAL PROJECTS, MAXIMUM WIDTH SHALL BE DETERMINED BY A TRUCK TURNING ANALYSIS, SUBJECT TO CITY APPROVAL. IF THIS STANDARD IS APPROVED FOR USE FOR BIKEWAY APPROACHES IN PARKS, WIDTH SHALL BE 16'.
- 4.) TYPE III APPROACH FOR PARKS AND TRAILS SHALL INCLUDE #4 REBARS AT 18" ON CENTER (2 DIRECTIONS).
- 5.) 4' LONG #4 SMOOTH ROUND BARS SHALL BE USED WHEN DRIVEWAY APPROACH IS NOT POURED MONOLITHICALLY.

NOT TO SCALE

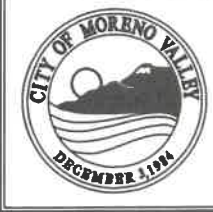

RECOMMENDED:  
*Henry* 12/16/25  
 DIVISION MANAGER DATE  
 APPROVED:  
*[Signature]* 2/4/22  
 PUBLIC WORKS DIRECTOR / DATE  
 CITY ENGINEER

**CITY OF MORENO VALLEY**  
 PUBLIC WORKS DEPARTMENT - CAPITAL PROJECTS DIVISION

**COMMERCIAL DRIVEWAY  
 APPROACH: TYPE 3**  
 (FOR NEW DEVELOPMENT)

STANDARD PLAN  
**MVSI-112C-0**  
 SHEET 3 OF 4



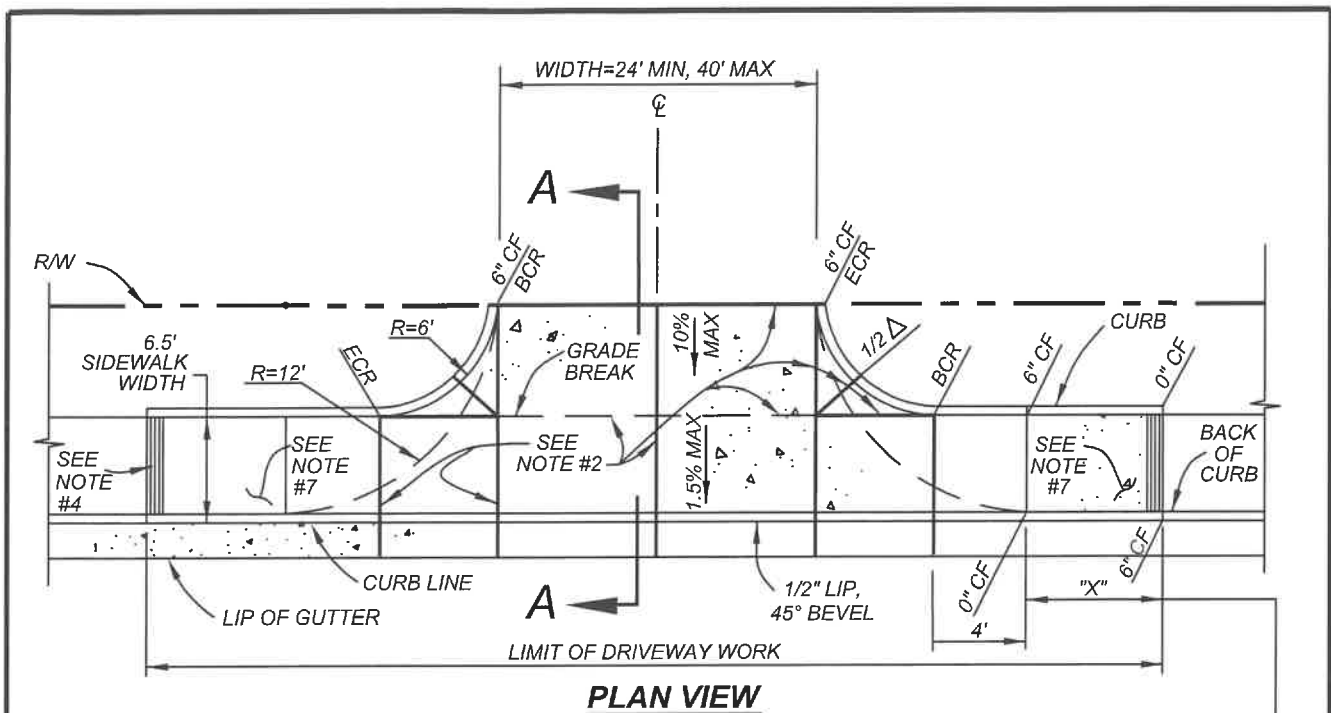

**PLAN VIEW**

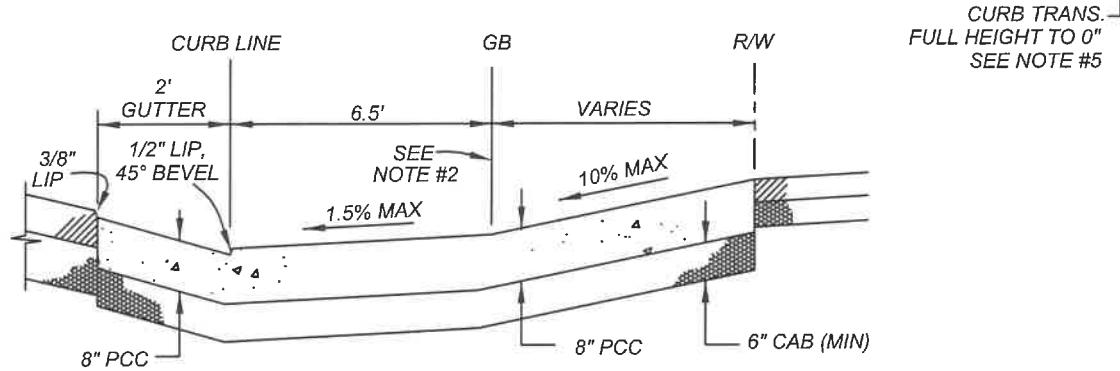

**SECTION "A-A"**

**NOTES:**

- 1.) TYPE IV APPROACH SHALL BE USED WHEN SIDEWALK IS ADJACENT TO CURB AND RIGHT-OF-WAY IS NOT AVAILABLE TO BUILD A TYPE III APPROACH.
- 2.) WEAKENED PLANE JOINT REQUIRED AT CENTERLINE OF APPROACH AND AT LOCATIONS AS SHOWN, SPACED 10' MAX AND AS NECESSARY.
- 3.) CONCRETE SHALL BE CLASS 560-C-3250, CURED WITH WHITE PIGMENTED CURING COMPOUND.
- 4.) TOP OF SIDEWALK RAMP SHALL HAVE A 12" WIDE BORDER WITH GROOVES 1/4" DEEP, WITH 1/8" RADIUS, AND SPACED AT 3/4" OC.
- 5.) "X" SHALL HAVE A MAXIMUM SLOPE OF 1:12 (8.33%), AND A MINIMUM SLOPE OF 1:15 (6.67%).
- 6.) RAMP SURFACE SHALL BE SLIP-RESISTANT AND SHALL BE OF CONTRASTING FINISH FROM ADJACENT SIDEWALK (ROUGH BROOM FINISH OR EQUIVALENT).
- 7.) ALL ACCESS RAMPS SHALL BE CONSTRUCTED TO THE MOST CURRENT REQUIREMENT OF THE AMERICANS WITH DISABILITIES ACT (ADA) STANDARDS/CALIFORNIA CODE OF REGULATIONS TITLE 24-ACCESSIBILITY REGULATIONS. ADJUSTMENTS SHALL BE MADE IN THE FIELD TO ACHIEVE RAMP CONDITIONS.
- 8.) FOR NEW DRIVEWAY APPROACHES ON EXISTING STREETS A 12" WIDTH OF ASPHALT CONCRETE SHALL BE REMOVED AND REPLACED TO FULL DEPTH.

NOT TO SCALE

	RECOMMENDED: <i>Henrygo</i> 7/16/19 DIVISION MANAGER DATE	<h2 style="margin: 0;">CITY OF MORENO VALLEY</h2> <p style="margin: 0;">PUBLIC WORKS DEPARTMENT - CAPITAL PROJECTS DIVISION</p>	STANDARD PLAN <h3 style="margin: 0;">MVSI-112D-0</h3>
	APPROVED: <i>M. L. W. J.</i> w/julia PUBLIC WORKS DIRECTOR / DATE CITY ENGINEER	<h3 style="margin: 0;">COMMERCIAL DRIVEWAY APPROACH: TYPE IV</h3>	SHEET 4 OF 4

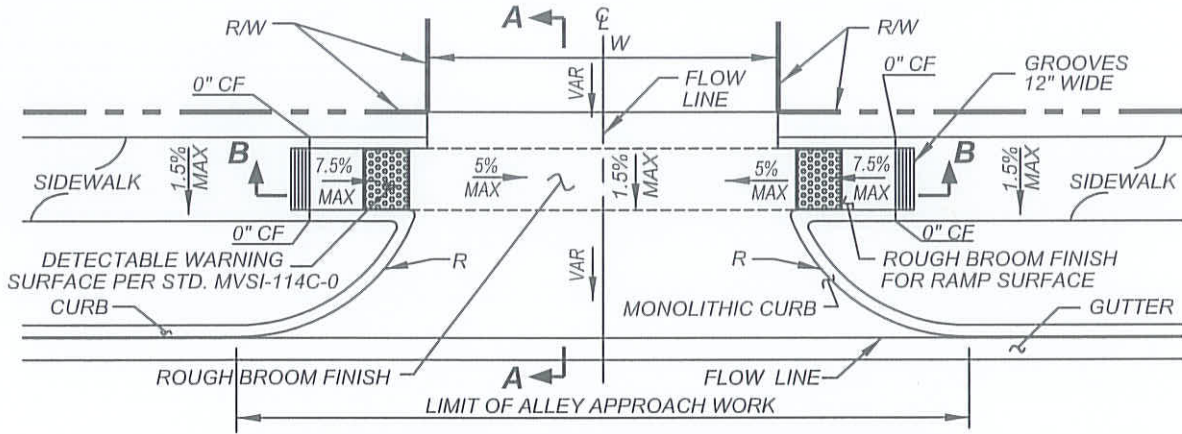

**AT CURB-SEPARATED SIDEWALK LOCATION**

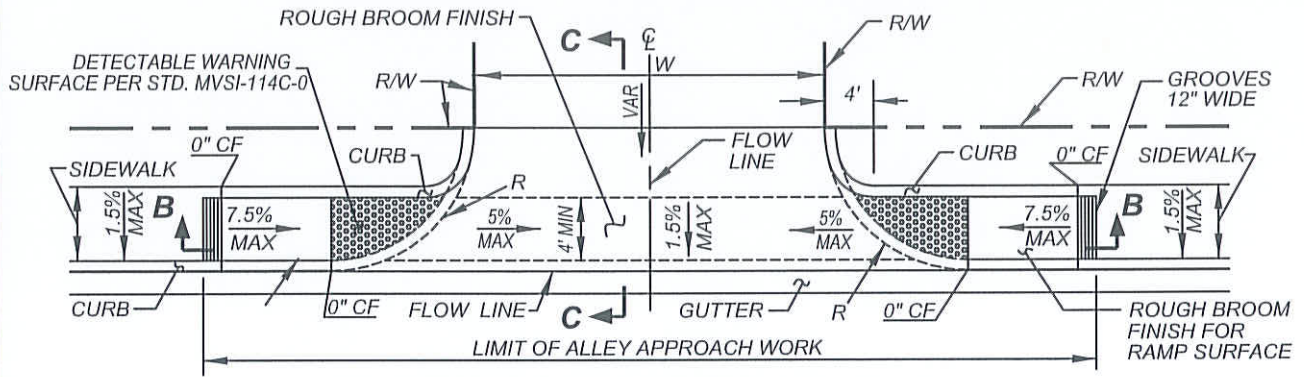

**AT CURB-ADJACENT SIDEWALK LOCATION**

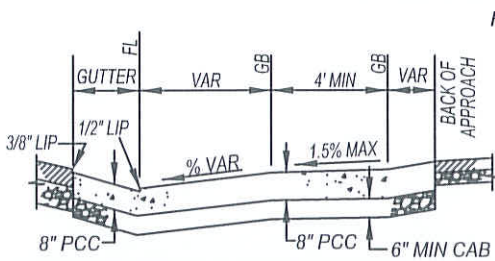

**SECTION "A-A"**

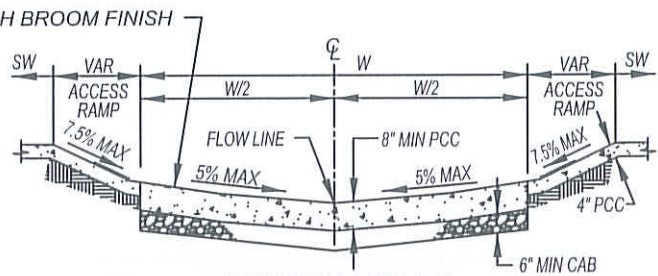

**SECTION "B-B"**

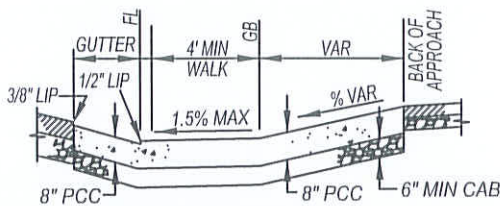

**SECTION "C-C"**

**NOTES:**

- 1.) CURB RETURNS SHALL HAVE A RADIUS (R) OF 12 FEET UNLESS OTHERWISE SPECIFIED. CURB RADIUS SHALL NOT EXCEED PARKWAY WIDTH.
- 2.) ALL CONCRETE SHALL BE CLASS 560-C-3250, CURED WITH WHITE PIGMENTED CURING COMPOUND.
- 3.) RAMP SURFACE SHALL BE SLIP-RESISTANT WITH ROUGH BROOM FINISH OR EQUIVALENT.

NOT TO SCALE

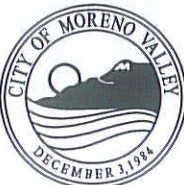

RECOMMENDED:

*[Signature]*  
DIVISION MANAGER / 1/21/14  
DATE

APPROVED:

*[Signature]*  
PUBLIC WORKS DIRECTOR / 1/20/14  
CITY ENGINEER / DATE

**CITY OF MORENO VALLEY**  
PUBLIC WORKS DEPARTMENT - CAPITAL PROJECTS DIVISION

**ALLEY APPROACH**

STANDARD PLAN  
**MVSI-113-0**

SHEET 1 OF 1

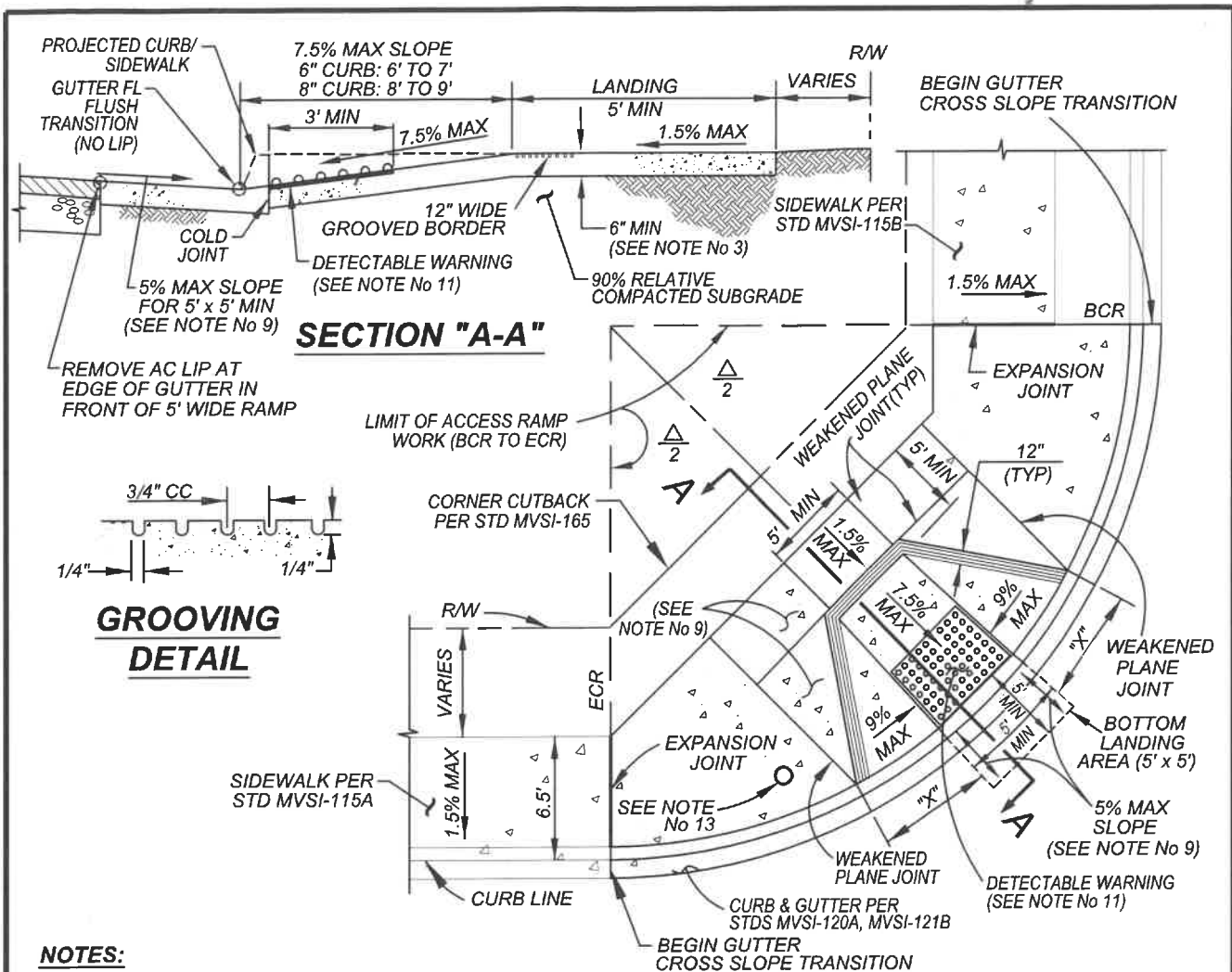

**NOTES:**

- 1.) ALL ACCESS RAMPS SHALL BE CONSTRUCTED TO THE MOST CURRENT REQUIREMENTS OF THE AMERICANS WITH DISABILITIES ACT (ADA) STANDARDS/CALIFORNIA CODE OF REGULATIONS TITLE 24-ACCESSIBILITY REGULATIONS. ADJUSTMENTS SHALL BE MADE IN THE FIELD TO ACHIEVE RAMP CONDITIONS.
- 2.) CONCRETE SHALL BE CLASS 560-C-3250, CURED WITH WHITE PIGMENTED CURING COMPOUND OVER 90% RELATIVE COMPACTION.
- 3.) THICKNESS OF RAMP AND LANDING AREAS AROUND THE RAMP WITHIN THE CURB RETURN, FROM BCR TO ECR, SHALL BE 6" MINIMUM. RAMP AND LANDING AREAS SHALL BE POURED MONOLITHIC.
- 4.) A 4' MINIMUM DEPTH LANDING IS REQUIRED AT THE TOP OF THE RAMP OVER THE ENTIRE RAMP WIDTH. CROSS SLOPE OF LANDING MAY NOT EXCEED 1.5% IN ANY DIRECTION.
- 5.) RAMP SIDES ALONG "X" SHALL HAVE A MAXIMUM SLOPE OF 10%.
- 6.) GROOVED BORDER SHALL BE 12" WIDE ALONG THE TOP AND SIDES OF THE RAMP AT THE LEVEL SURFACE OF THE SIDEWALK. OMIT GROOVES ADJACENT TO NON-PAVED AREAS.
- 7.) RAMP SURFACE AND FLARED SIDES SHALL BE SLIP-RESISTANT (ROUGH BROOM FINISH OR EQUIVALENT) AND SHALL BE OF CONTRAST FINISH FROM ADJACENT SIDEWALK (MEDIUM BROOM FINISH).
- 8.) SEE STANDARD PLAN MVL-432 FOR CROSSWALK LOCATION DETAIL. SEE STANDARD PLAN MVSI-165 FOR R/W CORNER CUT-BACK.
- 9.) SLOPES JOINING BOTTOM OF THE RAMP (I.E. ROAD GUTTERS) SHALL NOT EXCEED 5%. THE SLOPES JOINING TOP OF RAMP SHALL NOT EXCEED 1.5%.
- 10.) DIMENSIONS SHOWN FOR SLOPING PORTIONS OF RAMP VARY DUE TO FIELD CONDITIONS.
- 11.) DETECTABLE WARNING SURFACES ARE REQUIRED ON ALL CURB RAMPS THAT ENTER INTO A VEHICULAR TRAVELED WAY. SEE STANDARD PLAN MVSI-114C FOR DETECTABLE WARNING SURFACE DETAILS AND NOTES.
- 12.) FOR NEW ACCESS RAMPS ON EXISTING STREETS, A 12" WIDTH OF PAVEMENT SHALL BE REMOVED AND REPLACED TO FULL DEPTH FOR CONSTRUCTION OF CURB AND GUTTER.
- 13.) FOR TRAFFIC SIGNAL LOCATIONS, A 30"x48" 2% MAXIMUM LANDING AREA SHALL BE LOCATED ADJACENT TO THE PEDESTRIAN PUSH BUTTON.

NOT TO SCALE



RECOMMENDED:

*Hennings* 8/14/19  
DIVISION MANAGER DATE

APPROVED:

*M. W. ...* 10/11/19  
PUBLIC WORKS DIRECTOR / DATE  
CITY ENGINEER

**CITY OF MORENO VALLEY**  
PUBLIC WORKS DEPARTMENT - CAPITAL PROJECTS DIVISION

**ACCESS RAMP - TYPE 1**

STANDARD PLAN  
**MVSI-114A-2**

SHEET 1 OF 4

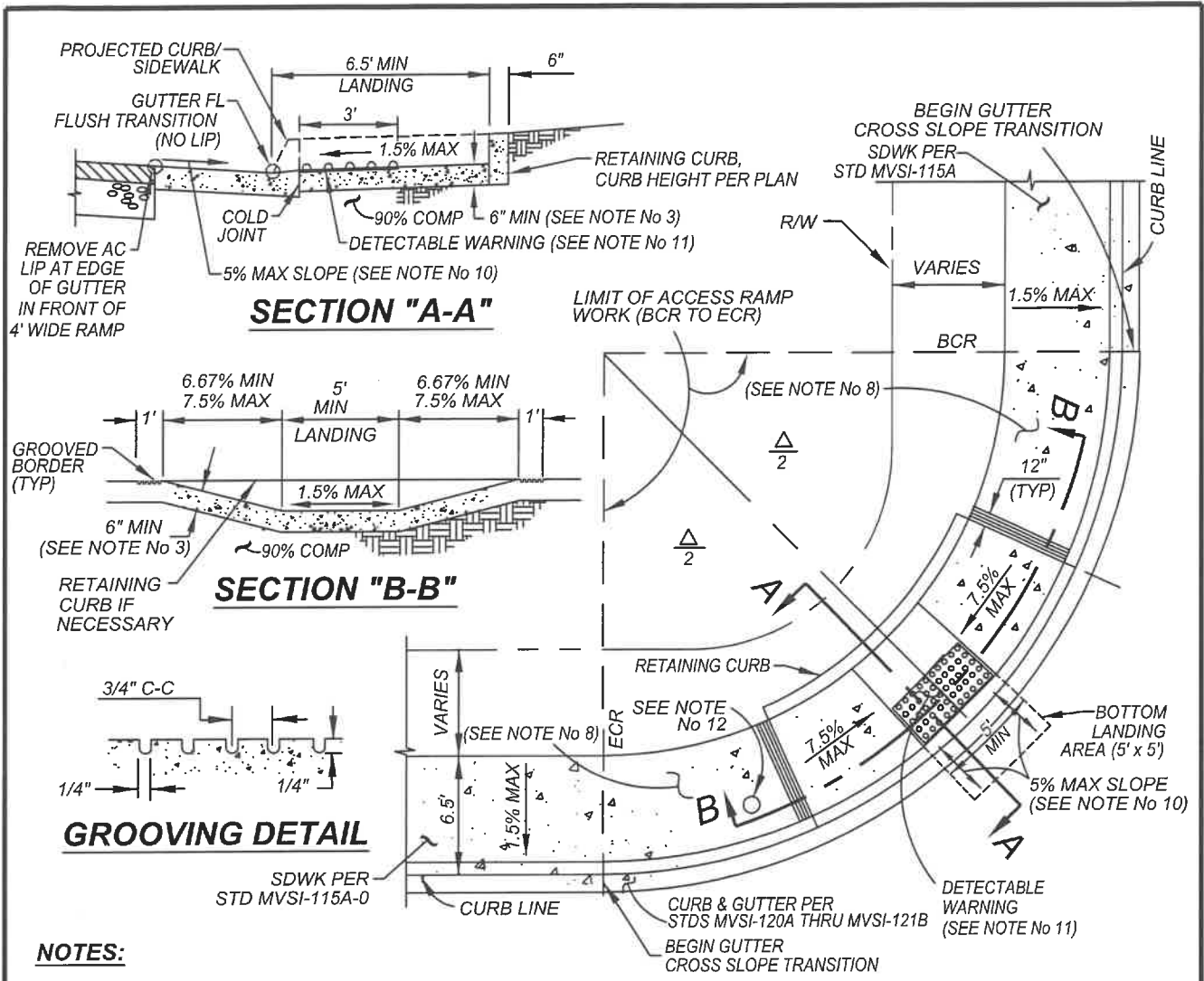

**NOTES:**

- 1.) TYPE 2 RAMP MAY BE USED WHEN MINIMUM DISTANCE OF 4' AT TOP OF TYPE 1 RAMP CANNOT BE ACHIEVED.
- 2.) ALL ACCESS RAMPS SHALL BE CONSTRUCTED TO THE MOST CURRENT REQUIREMENTS OF THE AMERICANS WITH DISABILITIES ACT (ADA) STANDARDS/CALIFORNIA CODE OF REGULATIONS TITLE 24-ACCESSIBILITY REGULATIONS. ADJUSTMENTS SHALL BE MADE IN THE FIELD TO ACHIEVE RAMP CONDITIONS.
- 3.) THICKNESS OF RAMP AND LANDING AREAS ON BOTH SIDES OF THE RAMP WITHIN CURB RETURN, FROM BCR TO ECR, SHALL BE 6" MINIMUM. RAMP AND LANDING AREAS SHALL BE POURED MONOLITHIC.
- 4.) CONCRETE SHALL BE CLASS 560-C-3250, CURED WITH WHITE PIGMENTED CURING COMPOUND OVER 90% RELATIVE COMPACTION.
- 5.) CROSS SLOPE OF LANDING MAY NOT EXCEED 1.5% IN ANY DIRECTION.
- 6.) RAMP SIDES SHALL HAVE A MAXIMUM SLOPE OF 7.5% AND A MINIMUM SLOPE OF 6.67%.
- 7.) GROOVED BORDER SHALL BE 12" WIDE ALONG THE TOP OF THE RAMP AT THE LEVEL SURFACE OF THE SIDEWALK. OMIT GROOVES ADJACENT TO NON-PAVED AREAS.
- 8.) RAMP SURFACE AND SIDES SHALL BE SLIP-RESISTANT (ROUGH BROOM FINISH OR EQUIVALENT) AND SHALL BE OF CONTRASTING FINISH FROM ADJACENT SIDEWALK.
- 9.) SEE STANDARD PLAN MVL-432 FOR CROSSWALK LOCATION DETAIL.
- 10.) SLOPES JOINING BOTTOM OF THE RAMP (I.E. ROAD GUTTERS) SHALL NOT EXCEED 5%. THE SLOPES JOINING TOP OF RAMP SHALL NOT EXCEED 1.5% IN ANY DIRECTION.
- 11.) DETECTABLE WARNING SURFACES ARE REQUIRED ON ALL CURB RAMPS THAT ENTER INTO A VEHICULAR TRAVELED WAY. SEE STANDARD PLAN MVSI-114C FOR DETECTABLE WARNING SURFACE DETAILS AND NOTES.
- 12.) FOR TRAFFIC SIGNAL LOCATIONS, A 30" x 48" 2% MAXIMUM LANDING AREA SHALL BE LOCATED ADJACENT TO THE PEDESTRIAN PUSH BUTTON.
- 13.) ALL EXPOSED CORNERS OF THE RETAINING CURB SHALL BE FINISHED WITH 1/2" RADIUS.

NOT TO SCALE



RECOMMENDED:  
*Henry* 7/16/19  
 DIVISION MANAGER DATE  
 APPROVED:  
*M. Lopez* 10/16/19  
 PUBLIC WORKS DIRECTOR / DATE  
 CITY ENGINEER

**CITY OF MORENO VALLEY**  
 PUBLIC WORKS DEPARTMENT - CAPITAL PROJECTS DIVISION

**ACCESS RAMP - TYPE 2**

STANDARD PLAN  
**MVSI-114B-2**  
 SHEET 2 OF 4

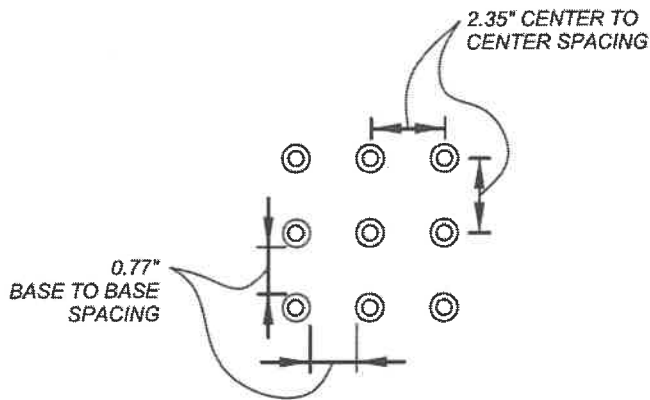

**RAISED TRUNCATED DOME PATTERN  
(IN-LINE)**

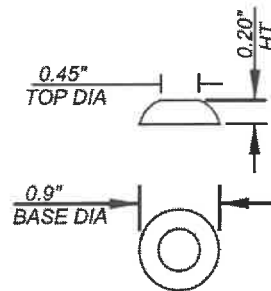

**RAISED TRUNCATED DOME**

DETECTABLE WARNING TILE  
MANUFACTURED BY ADA SOLUTIONS  
PRODUCT COMPANY OR APPROVED EQUAL

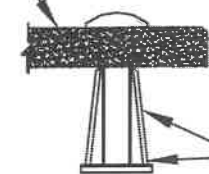

**ANCHOR DETAIL**

STEEL CONCRETE ANCHOR  
MANUFACTURED BY ADA SOLUTIONS  
PRODUCT COMPANY OR APPROVED EQUAL

**NOTES:**

- 1.) DETECTABLE WARNING, MOUNTED FLUSH, SURFACE SHALL BE CAST-IN-PLACE DETECTABLE WARNING TILE WITH STEEL ANCHORS, MANUFACTURED BY ADA SOLUTIONS OR APPROVED EQUAL, AND SHALL MEET ALL ADA REQUIREMENTS AS WELL AS STATE TITLE 24 REQUIREMENTS.
- 2.) COLOR SHALL BE YELLOW CONFORMING TO FEDERAL STANDARD 595B, COLOR No 33538.
- 3.) DETECTABLE WARNING SURFACE SHALL CONFORM TO THE DETAILS ON THIS STANDARD PLAN.
- 4.) DETECTABLE WARNING SURFACE SHALL BE FULL WIDTH OF RAMP AND 3 FOOT MINIMUM IN DEPTH OF RAMP AND UTILIZE A SINGLE PIECE.
- 5.) DETECTABLE WARNING SURFACE SHALL BE INSTALLED SO THAT DOMES ARE ALIGNED PARALLEL TO CENTERLINE OF ACCESS RAMP.
- 6.) THE EDGE OF THE DETECTABLE WARNING SURFACE NEAREST THE STREET SHALL BE BETWEEN 6" AND 8" FROM THE GUTTER FLOW LINE.
- 7.) RETROFIT INSTALLATION SHALL BE DETECTABLE WARNING TILE (PER NOTE 1) TIED DOWN TO EXISTING RAMP SURFACE WITH ANCHORS AND SEALED WITH WATERPROOFING ADHESIVE. NO SELF-ADHESIVE SURFACE APPLIED DOME MATS ALLOWED. TILE SHALL BE INSTALLED FLUSH WITH THE RAMP SURFACE. PERIMETER "LIP" SHALL NOT EXCEED 1/4".

NOT TO SCALE

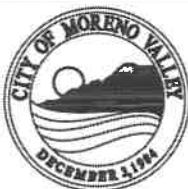

RECOMMENDED:

*Henry* 7/16/19  
DIVISION MANAGER DATE

APPROVED:

*McW...* 10/16/19  
PUBLIC WORKS DIRECTOR / DATE  
CITY ENGINEER

**CITY OF MORENO VALLEY**  
PUBLIC WORKS DEPARTMENT - CAPITAL PROJECTS DIVISION

**DETECTABLE WARNING SURFACE  
DETAILS AND NOTES**

STANDARD PLAN  
**MVSI-114C-2**

SHEET 3 OF 4



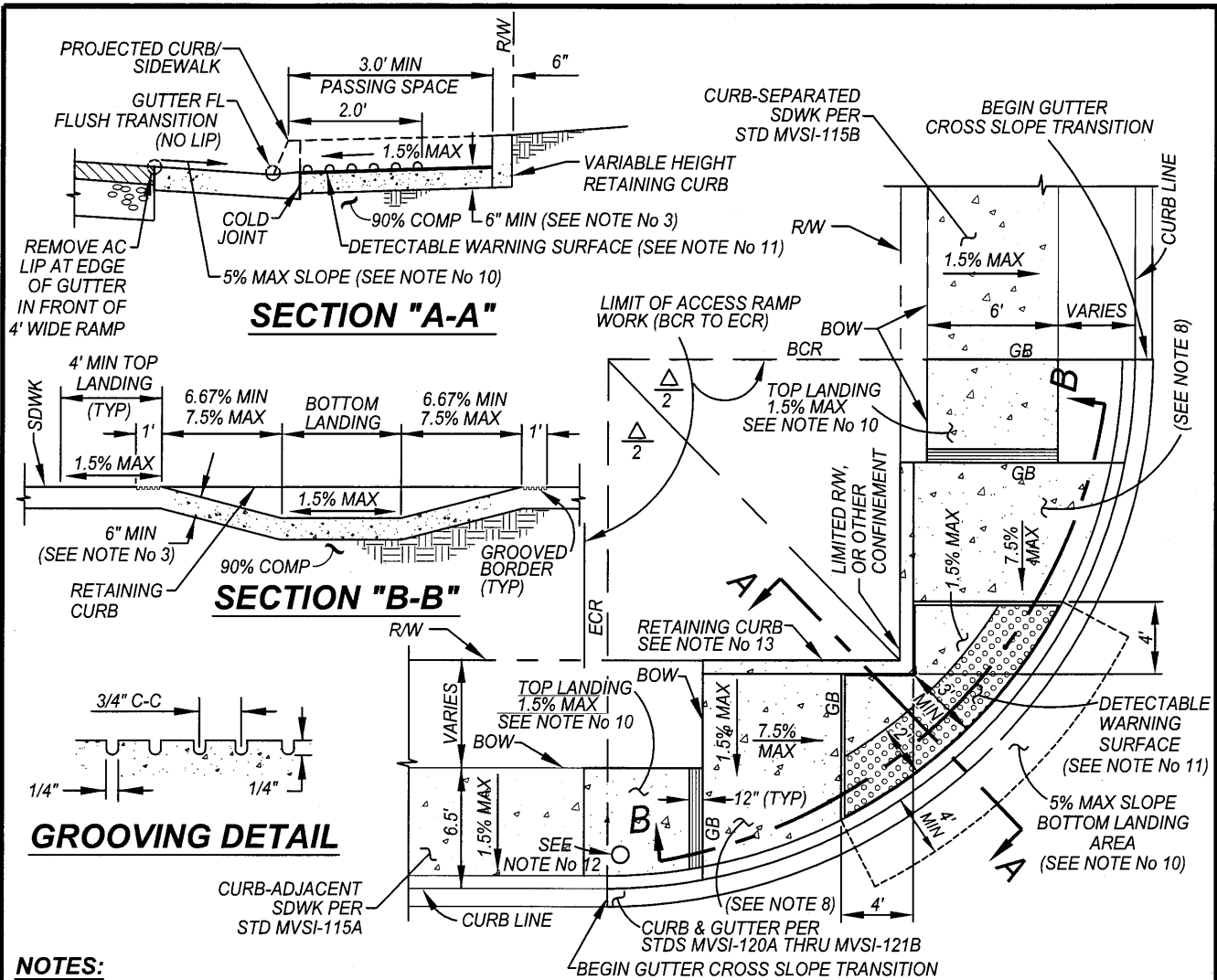



**NOTES:**

- 1.) ALTERNATE TYPE 2 RAMP MAY BE USED FOR CAPITAL IMPROVEMENTS, WITH APPROVAL, WHEN A STANDARD TYPE 1 OR TYPE 2 RAMP CANNOT BE ACHIEVED DUE TO CONFINEMENT RESTRICTIONS SUCH AS R/W OR OTHER PHYSICAL CONSTRAINTS.
- 2.) ALL ACCESS RAMPS SHALL BE CONSTRUCTED TO THE MOST CURRENT REQUIREMENTS OF THE AMERICANS WITH DISABILITIES ACT (ADA) STANDARDS/CALIFORNIA CODE OF REGULATIONS TITLE 24-ACCESSIBILITY REGULATIONS. ADJUSTMENTS SHALL BE MADE IN THE FIELD TO ACHIEVE RAMP CONDITIONS.
- 3.) THICKNESS OF RAMP AND LANDING AREAS ON BOTH SIDES OF THE RAMP WITHIN CURB RETURN, FROM BCR TO ECR, OR BEYOND BCR/ECR AS REQUIRED, SHALL BE 6" MINIMUM. RAMP AND LANDING AREAS SHALL BE POURED MONOLITHICALLY.
- 4.) CONCRETE SHALL BE CLASS 560-C-3250, CURED WITH WHITE PIGMENTED CURING COMPOUND.
- 5.) CROSS SLOPE OF LANDING SHALL NOT EXCEED 1.5% IN ANY DIRECTION.
- 6.) RAMP SIDES SHALL HAVE A MAXIMUM SLOPE OF 7.5% AND A MINIMUM SLOPE OF 6.67%.
- 7.) GROOVED BORDER SHALL BE 12" WIDE ALONG THE TOP OF THE RAMP AT THE LEVEL SURFACE OF THE SIDEWALK. OMIT GROOVES ADJACENT TO NON-PAVED AREAS.
- 8.) RAMP SURFACE AND SIDES SHALL BE SLIP-RESISTANT (ROUGH BROOM FINISH OR EQUIVALENT) AND SHALL BE OF CONTRASTING FINISH FROM ADJACENT SIDEWALK.
- 9.) SEE STANDARD PLAN MVL-432 FOR CROSSWALK LOCATION DETAIL.
- 10.) SLOPES JOINING BOTTOM OF THE RAMP (I.E. ROAD GUTTERS) SHALL NOT EXCEED 5%. THE SLOPES JOINING TOP OF RAMP (TOP LANDING) SHALL NOT EXCEED 1.5% IN ANY DIRECTION FOR 4' MIN.
- 11.) DETECTABLE WARNING SURFACES ARE REQUIRED ON ALL CURB RAMPS THAT ENTER INTO A VEHICULAR TRAVELED WAY. SEE STANDARD PLAN MVS-114C FOR DETECTABLE WARNING SURFACE DETAILS AND NOTES.
- 12.) FOR TRAFFIC SIGNAL LOCATIONS, A 30"x48" 2% MAXIMUM LANDING AREA SHALL BE LOCATED ADJACENT TO THE PEDESTRIAN PUSH BUTTON.
- 13.) ALL EXPOSED CORNERS OF THE RETAINING CURB SHALL BE FINISHED WITH 1/2" RADIUS.

NOT TO SCALE

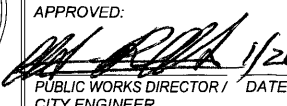
	RECOMMENDED:  DIVISION MANAGER	1-6-17 DATE	<h2 style="margin: 0;">CITY OF MORENO VALLEY</h2> <p style="margin: 0;">PUBLIC WORKS DEPARTMENT - CAPITAL PROJECTS DIVISION</p>
	APPROVED:  PUBLIC WORKS DIRECTOR / CITY ENGINEER	1/20/17 DATE	<h3 style="margin: 0;">ACCESS RAMP - ALTERNATE TYPE 2 (CONFINED SPACE)</h3> <p style="margin: 0;">(NOT TO BE USED FOR NEW DEVELOPMENT)</p>
			STANDARD PLAN <h3 style="margin: 0;">MVS-114D-0</h3> <p style="margin: 0;">SHEET 4 OF 4</p>



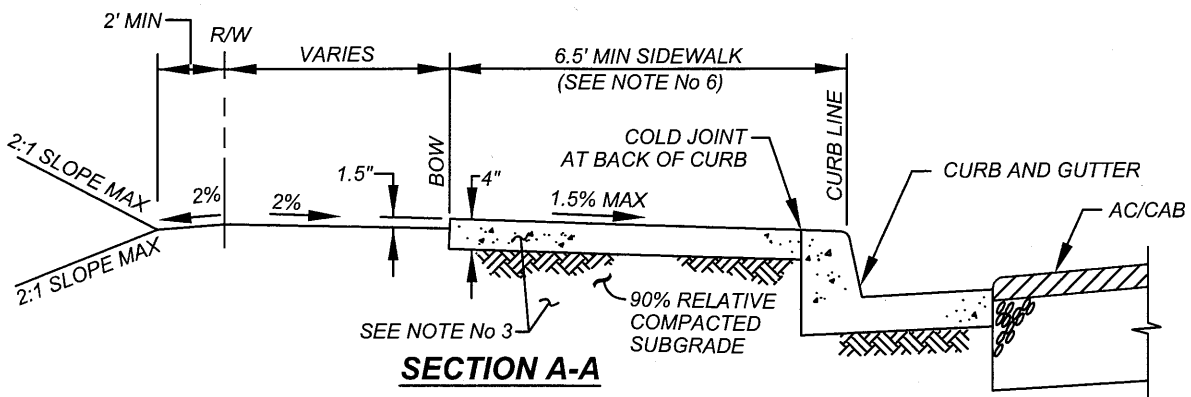

**SECTION A-A**

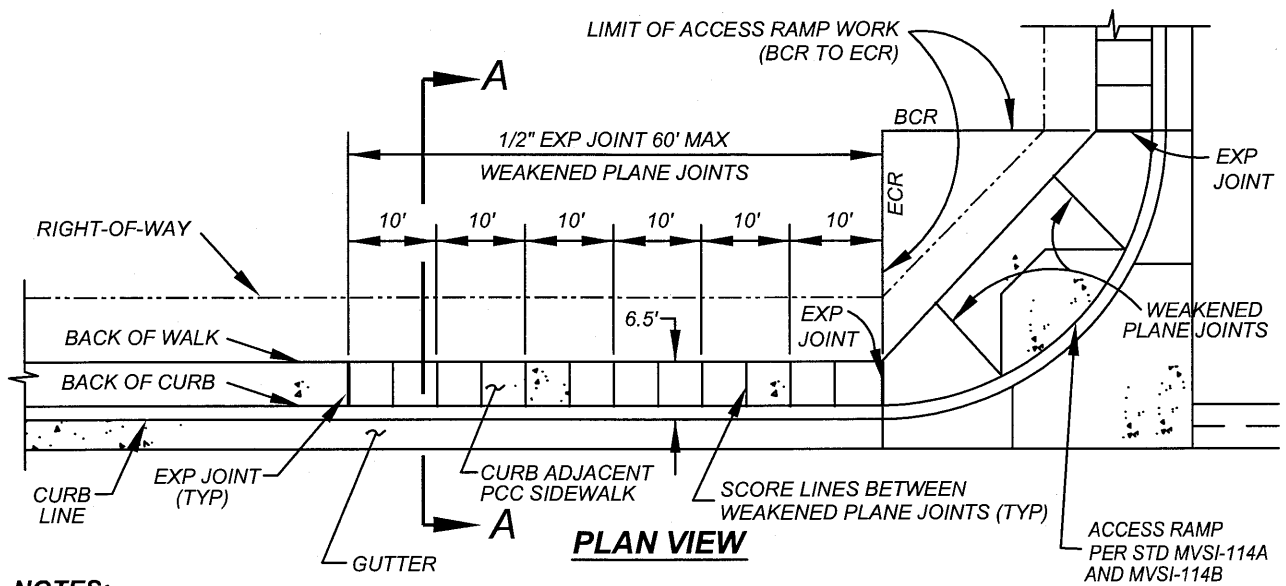

**PLAN VIEW**

**NOTES:**

- 1.) THICKNESS OF SIDEWALK SHALL BE 4" EXCEPT IN DRIVEWAY APRONS, WHERE 6" IS REQUIRED FOR SINGLE FAMILY RESIDENTIAL DRIVEWAYS, AND 8" IS REQUIRED FOR COMMERCIAL DRIVEWAYS.
- 2.) SIDEWALK SHALL HAVE 1/2" WIDE PREMOLDED EXPANSION JOINTS AND 1- 1/2" DEEP WEAKENED PLANE JOINTS AT INTERVALS SHOWN HEREON. JOINTS SHALL HAVE EDGES WITH 1/4" RADIUS.
- 3.) CONCRETE SHALL BE CLASS 560-C-3250, MEDIUM BROOM FINISH, CURED WITH WHITE PIGMENTED CURING COMPOUND OVER 90% RELATIVE COMPACTED SUBGRADE. ALTERNATIVELY, IF APPROVED BY THE CITY ENGINEER, PERVIOUS PCC MAY BE USED. PERVIOUS PCC AND SUBGRADE SHALL MEET THE REQUIREMENTS OF SECTIONS 303-8 AND 201-1.1.6 OF THE STANDARD SPECIFICATIONS FOR PUBLIC WORKS CONSTRUCTION, LATEST EDITION.
- 4.) 18" MOISTURE PENETRATION REQUIRED PRIOR TO PLACING CONCRETE IN SIDEWALK AREA (NON-EXPANSIVE SOIL AS DETERMINED BY SOILS TEST ARE EXEMPT AND REQUIRE ONLY SURFACE WETTING).
- 5.) SIDEWALKS SHALL BE FORMED IN SUCH A MANNER AS TO MAINTAIN 48" MINIMUM OF UNOBSTRUCTED PEDESTRIAN WAY AT ALL LOCATIONS, INCLUDING BUT NOT LIMITED TO STREET LIGHTS, ELECTROLIERS, POWER POLES, AND FIRE HYDRANTS. SEE STANDARD MVS-115D.
- 6.) FOR NEW DEVELOPMENT, CURB ADJACENT SIDEWALK WIDTH SHALL BE 6.5' MINIMUM. SIDEWALK WIDTH OF LESS THAN 6.5' MAY BE USED TO REPLACE SHORT LENGTH OF EXISTING SIDEWALK TO MATCH EXISTING AS APPROVED BY CITY ENGINEER.
- 7.) WHERE NEW 6.5' WIDE SIDEWALK JOINS EXISTING NARROWER SIDEWALK, A 5:1 TRANSITION IS REQUIRED.

NOT TO SCALE

	RECOMMENDED: <i>HN</i> 8/29/18 DIVISION MANAGER      DATE	<b>CITY OF MORENO VALLEY</b> PUBLIC WORKS DEPARTMENT - CAPITAL PROJECTS DIVISION	
	APPROVED: <i>M. M. M.</i> 9/14/18 PUBLIC WORKS DIRECTOR / DATE CITY ENGINEER	<b>SIDEWALK</b>	STANDARD PLAN <b>MVSI-115A-0</b>

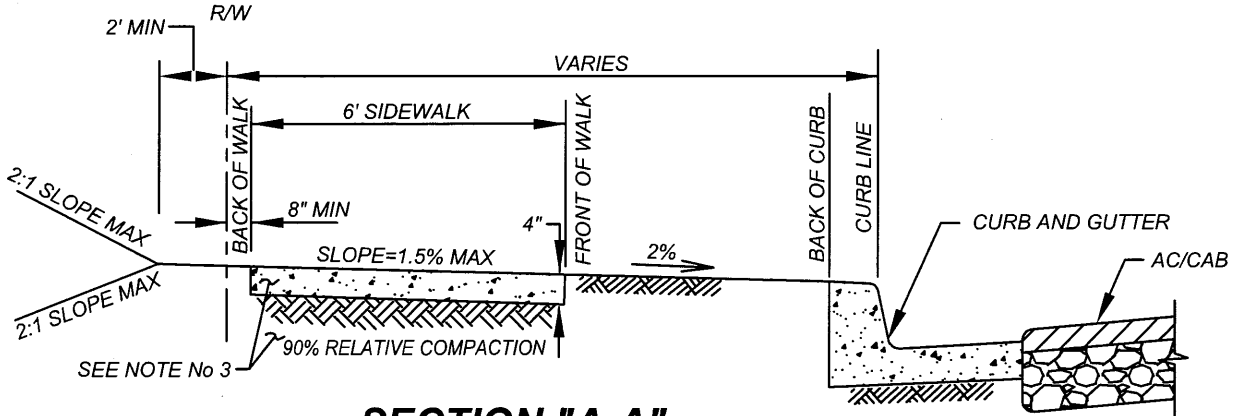

**SECTION "A-A"**

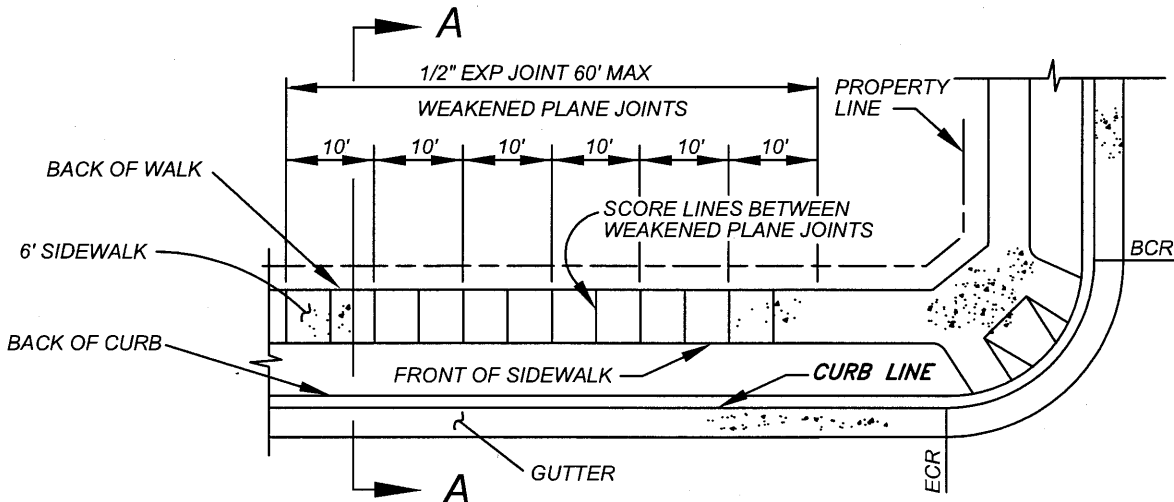

**PLAN VIEW**

**NOTES:**

- 1.) THICKNESS OF SIDEWALK SHALL BE 4" EXCEPT IN DRIVEWAY APRONS WHERE 6" IS REQUIRED FOR RESIDENTIAL DRIVEWAYS AND 8" IS REQUIRED FOR COMMERCIAL DRIVEWAYS.
- 2.) SIDEWALK SHALL HAVE 1/2" WIDE PREMOLDED EXPANSION JOINTS AND 1- 1/2" DEEP WEAKENED PLANE JOINTS AT INTERVALS SHOWN HEREON. JOINTS SHALL HAVE EDGES WITH 1/4" RADIUS.
- 3.) CONCRETE SHALL BE CLASS 560-C-3250, MEDIUM BROOM FINISH, CURE WITH WHITE PIGMENTED CURING COMPOUND OVER 90% RELATIVE COMPACTED SUBGRADE. ALTERNATIVELY, IF APPROVED BY THE CITY ENGINEER, PERVIOUS PCC MAY BE USED. PERVIOUS PCC AND SUBGRADE SHALL MEET THE REQUIREMENTS OF SECTIONS 303-8 AND 201-1.1.6 OF THE STANDARD SPECIFICATIONS FOR PUBLIC WORKS. CONSTRUCTION, LATEST EDITION.
- 4.) 18" MOISTURE PENETRATION REQUIRED PRIOR TO PLACING CONCRETE IN SIDEWALK AREA (NON-EXPANSIVE SOIL AS DETERMINED BY SOILS TEST ARE EXEMPT AND REQUIRE ONLY SURFACE WETTING.)
- 5.) PARKWAY FROM CURB TO PROPERTY LINE TO BE BROUGHT TO GRADE BY CONTRACTOR BEFORE FINAL APPROVAL.
- 6.) SIDEWALKS SHALL BE FORMED IN SUCH A MANNER AS TO MAINTAIN 48" MINIMUM OF UNOBSTRUCTED PEDESTRIAN WAY AT ALL LOCATIONS, INCLUDING BUT NOT LIMITED TO STREET LIGHTS, ELECTROLIERS, POWER POLES, AND FIRE HYDRANTS. SEE STD MVS1-115D.
- 7.) WHERE NEW 6.0' WIDE SIDEWALK JOINS EXISTING NARROWER SIDEWALK, A 5:1 TRANSITION IS REQUIRED.

NOT TO SCALE

	RECOMMENDED:  DIVISION MANAGER      1-6-17 DATE	<b>CITY OF MORENO VALLEY</b> PUBLIC WORKS DEPARTMENT - CAPITAL PROJECTS DIVISION	
	APPROVED:  PUBLIC WORKS DIRECTOR / DATE CITY ENGINEER      1/20/17	<b>CURB SEPARATED SIDEWALK</b>	

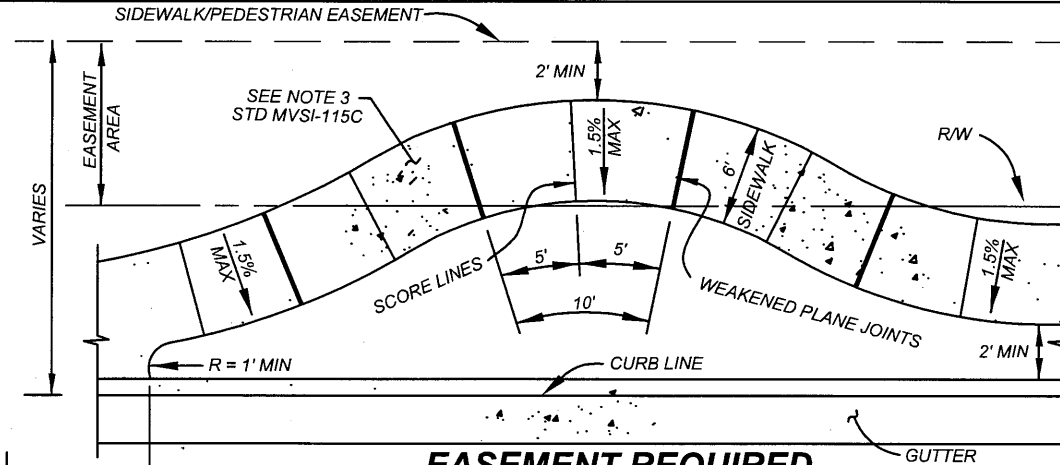
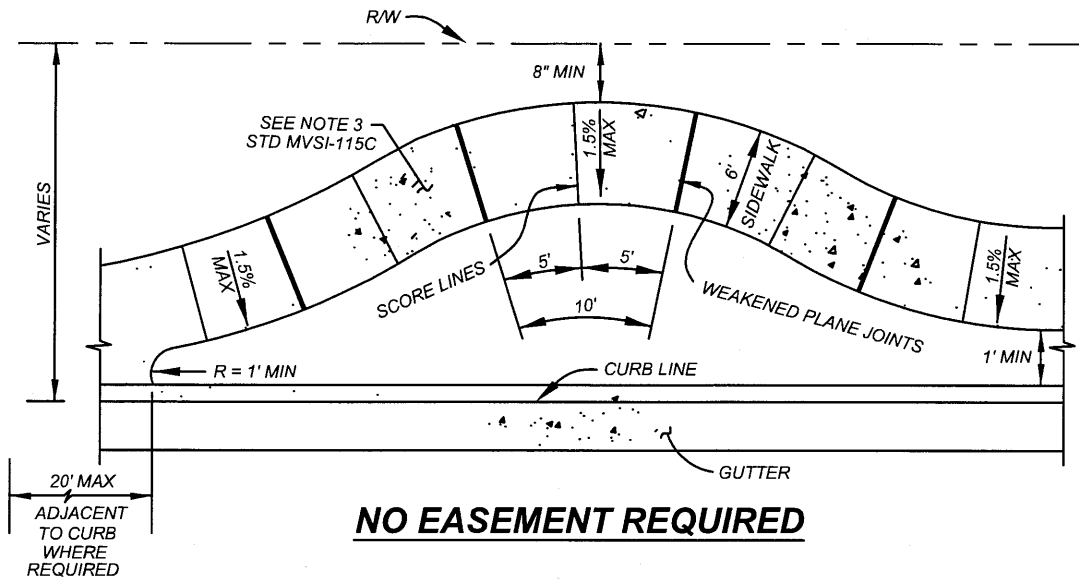

**NOTES:**

- 1.) THICKNESS OF SIDEWALK SHALL BE 4" EXCEPT IN DRIVEWAY APRONS WHERE 6" IS REQUIRED FOR RESIDENTIAL DRIVEWAYS AND 8" IS REQUIRED FOR COMMERCIAL DRIVEWAYS.
- 2.) SIDEWALK SHALL HAVE 1/2" WIDE PREMOLDED EXPANSION JOINTS (AT 60' MAXIMUM SPACING) AND 1-1/2" DEEP WEAKENED PLANE JOINTS AT INTERVALS SHOWN HEREON. JOINTS SHALL HAVE EDGES WITH 1/4" RADIUS.
- 3.) CONCRETE SHALL BE CLASS 560-C-3250, MEDIUM BROOM FINISH, CURED WITH WHITE PIGMENT CURING COMPOUND OVER 90% RELATIVE COMPACTED SUBGRADE. ALTERNATIVELY, IF APPROVED BY THE CITY ENGINEER, PERVIOUS PCC MAY BE USED. PERVIOUS PCC AND SUBGRADE SHALL MEET THE REQUIREMENTS OF SECTIONS 303-8 AND 201-1.1.6 OF THE STANDARD SPECIFICATIONS FOR PUBLIC WORKS CONSTRUCTION, LATEST EDITION.
- 4.) 18" MOISTURE PENETRATION REQUIRED PRIOR TO PLACING CONCRETE IN SIDEWALK AREA (NON-EXPANSIVE SOIL AS DETERMINED BY SOIL TEST ARE EXEMPT AND REQUIRE ONLY SURFACE WETTING.)
- 5.) PARKWAY FROM CURB TO PROPERTY LINE TO BE BROUGHT TO GRADE BY CONTRACTOR BEFORE FINAL APPROVAL.
- 6.) SIDEWALKS SHALL BE FORMED IN SUCH A MANNER AS TO MAINTAIN 48" MINIMUM OF UNOBSTRUCTED PEDESTRIAN WAY AT ALL LOCATIONS, INCLUDING BUT NOT LIMITED TO STREET LIGHTS, ELECTROLIERS, POWER POLES, AND FIRE HYDRANTS. SEE STD MVS1-115D.
- 7.) SIDEWALK SHALL MEANDER AS DETERMINED BY THE CITY ENGINEER.
- 8.) ALL CROSS SLOPES ON SIDEWALK WILL BE 1.5% MAXIMUM.

NOT TO SCALE

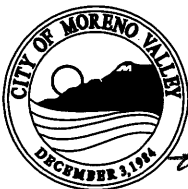

RECOMMENDED:

*[Signature]* 1-6-17  
DIVISION MANAGER DATE

APPROVED:

*[Signature]* 1/20/17  
PUBLIC WORKS DIRECTOR / DATE  
CITY ENGINEER

**CITY OF MORENO VALLEY**

PUBLIC WORKS DEPARTMENT - CAPITAL PROJECTS DIVISION

**MEANDERING SIDEWALK**

STANDARD PLAN

**MVS1-115C-0**

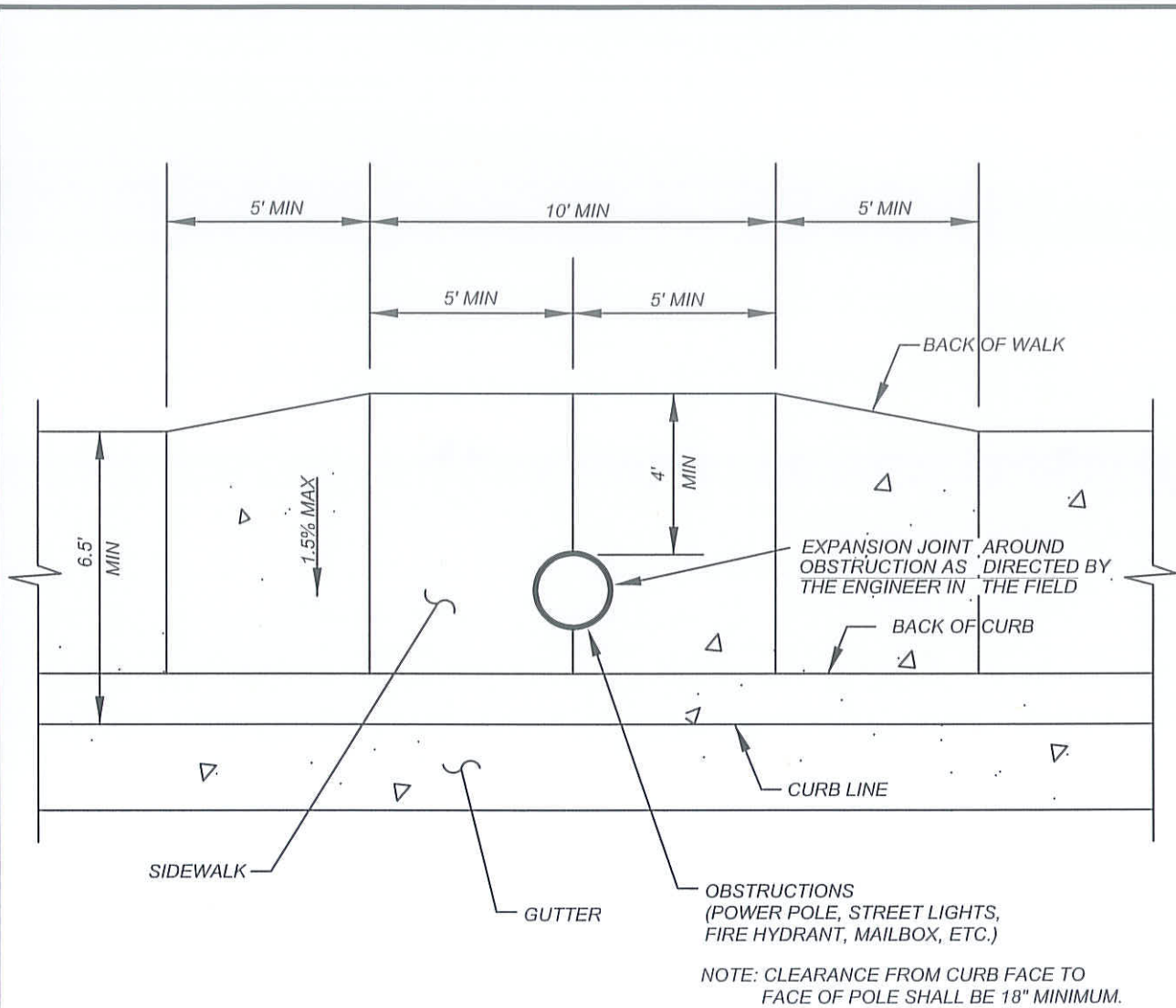

SHEET 3 OF 4



**NOTES:**

- 1.) SIDEWALK SHALL WIDEN TO MINIMUM 4' CLEARANCE FOR A MINIMUM LENGTH OF 10', CENTERED AROUND OBSTRUCTION.
- 2.) MINIMUM TRANSITION LENGTH SHALL BE 5'.
- 3.) ALL CROSS SLOPES ON SIDEWALK WILL BE 1.5% MAXIMUM.

NOT TO SCALE

	RECOMMENDED:  / 1/21/14 DIVISION MANAGER / DATE	<h2 style="margin: 0;">CITY OF MORENO VALLEY</h2> <p style="margin: 0;">PUBLIC WORKS DEPARTMENT - CAPITAL PROJECTS DIVISION</p>	STANDARD PLAN <b>MVSI-115D-0</b>
	APPROVED:  / 1/29/14 PUBLIC WORKS DIRECTOR / DATE CITY ENGINEER	<h3 style="margin: 0;">SIDEWALK PLACEMENT AROUND OBSTRUCTIONS</h3>	

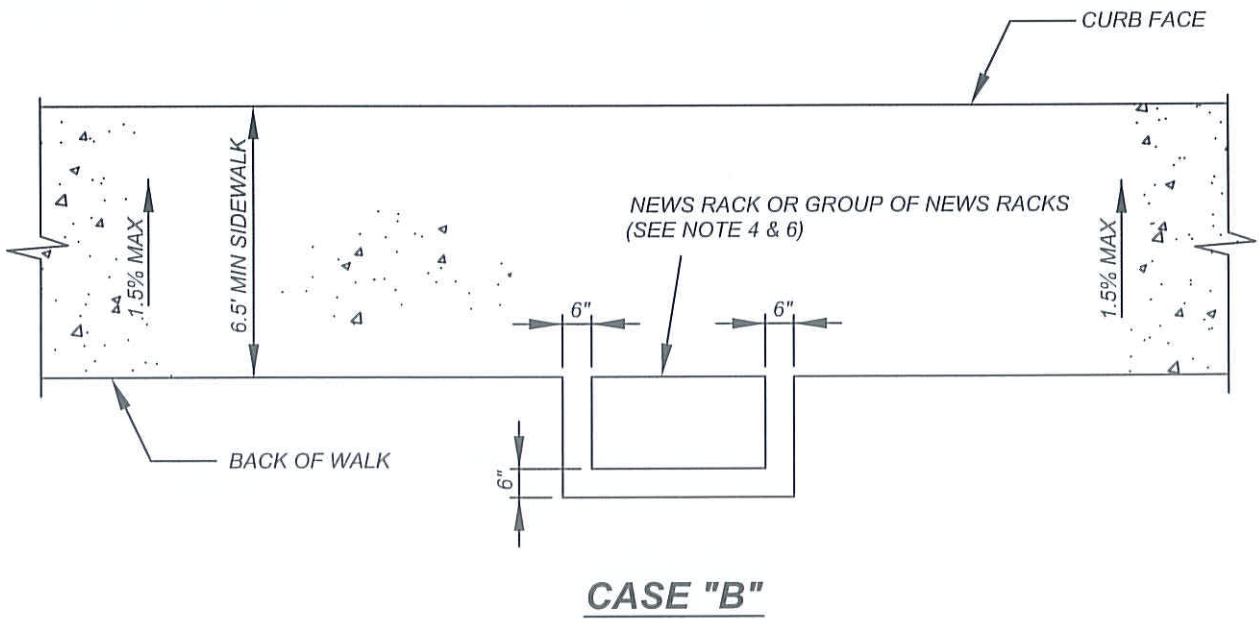
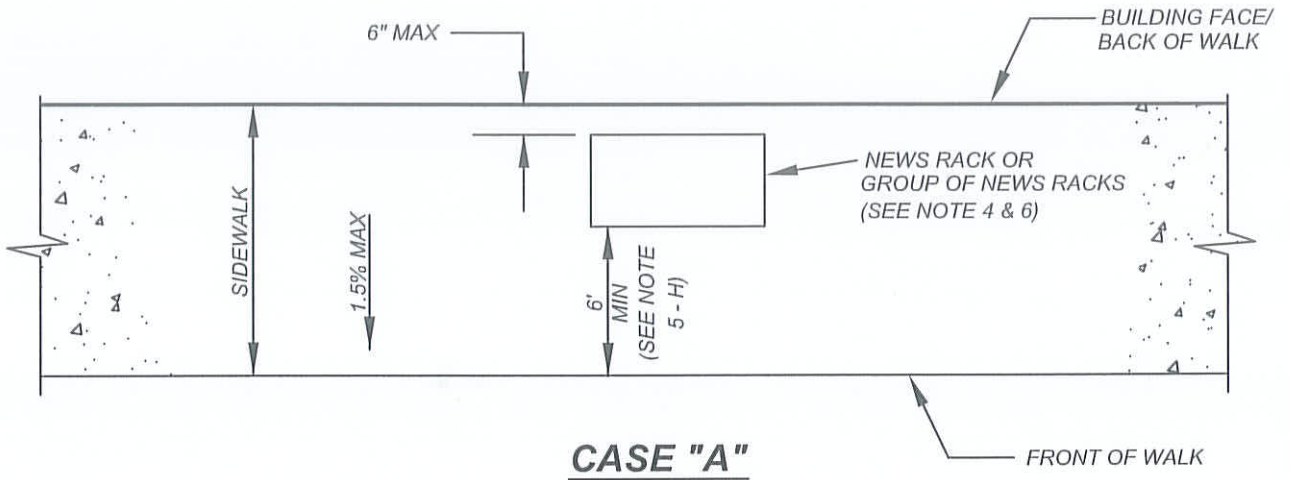

NOT TO SCALE

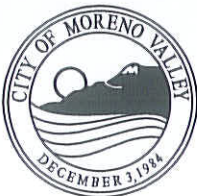

RECOMMENDED:  
 1/21/14  
 DIVISION MANAGER DATE

APPROVED:  
 1/29/14  
 PUBLIC WORKS DIRECTOR / DATE  
 CITY ENGINEER

**CITY OF MORENO VALLEY**  
 PUBLIC WORKS DEPARTMENT - CAPITAL PROJECTS DIVISION

**NEWS RACK INSTALLATION  
 AND PLACEMENT**

STANDARD PLAN  
**MVSI-116A-0**



**NOTES:**

- 1.) NO NEWS RACK SHALL BE INSTALLED, USED OR MAINTAINED WHICH PROJECTS ONTO, INTO OR OVER ANY PART OF THE ROADWAY OR PUBLIC STREET, OR WHICH RESTS, WHOLLY OR IN PART UPON, ALONG, OR OVER ANY PORTION OF THE ROADWAY OF ANY PUBLIC STREET.
- 2.) NEWS RACK PLACED ADJACENT TO THE WALL OF A BUILDING SHALL BE PLACED PARALLEL TO SUCH WALL AND NOT MORE THAN SIX (6) INCHES FROM THE WALL.
- 3.) EXCEPT WITH THE WRITTEN PERMISSION OF THE OWNER OF SUCH PROPERTY, NO NEWS RACK SHALL BE CHAINED, BOLTED OR OTHERWISE ATTACHED TO ANY PROPERTY NOT OWNED BY THE OWNER OF THE NEWS RACK OR TO ANY PERMANENTLY FIXED OBJECT.
- 4.) NO NEWS RACK SHALL BE CHAINED, BOLTED, OR OTHERWISE ATTACHED TO ANY FIXTURE LOCATED IN THE PUBLIC RIGHT-OF-WAY, EXCEPT TO OTHER NEWS RACK. NO MORE THAN SIX NEWS RACK MAY BE JOINED TOGETHER IN THIS MANNER, AND A SPACE OF NO LESS THAN THREE (3) FEET SHALL SEPARATE EACH GROUP OF SIX NEWS RACK SO ATTACHED.
- 5.) NO NEWS RACK SHALL BE PLACED, INSTALLED, USED OR MAINTAINED:
  - A. WITHIN FIVE (5) FEET OF ANY MARKED CROSSWALK;
  - B. WITHIN FIFTEEN (15) FEET OF THE CURB RETURN OF ANY UNMARKED CROSSWALK;
  - C. WITHIN FIVE (5) FEET OF ANY FIRE HYDRANT, FIRE CALL BOX, POLICE CALL BOX OR OTHER EMERGENCY FACILITY;
  - D. WITHIN FIVE (5) FEET OF ANY DRIVEWAY;
  - E. WITHIN THREE (3) FEET AHEAD OR TWENTY-FIVE (25) FEET TO THE REAR OF ANY SIGN MARKING A DESIGNATED BUS STOP;
  - F. WITHIN FIVE (5) FEET OF THE OUTER END OF ANY BUS BENCH;
  - G. WITHIN FIVE (5) FEET OF ANY SIDEWALK OBSTRUCTION WHICH SHALL INCLUDE, BUT NOT BE LIMITED TO: TRAFFIC SIGNALS, STREET LIGHT POLES, TREES, SIGN POSTS, TELEPHONE AND UTILITY POLES;
  - H. AT ANY LOCATION WHEREBY THE CLEAR SPACE FOR THE PASSAGEWAY OF PEDESTRIANS IS REDUCED TO LESS THAN SIX (6) FEET;
  - I. WITHIN THREE (3) FEET OF OR ON ANY PUBLIC AREA IMPROVED WITH LAWN, FLOWERS, SHRUBS, TREES OR OTHER LANDSCAPING, OR WITHIN THREE (3) FEET OF ANY DISPLAY WINDOW OF ANY BUILDING ABUTTING THE SIDEWALK OR PARKWAY OR IN SUCH A MANNER AS TO INTERFERE WITH THE REASONABLE USE OF SUCH WINDOW FOR DISPLAY PURPOSES;
  - J. WITHIN ONE HUNDRED (100) FEET OF ANY OTHER NEWS RACK ON THE SAME SIDE OF THE STREET IN THE SAME BLOCK CONTAINING THE SAME ISSUE OR EDITION OF THE SAME PUBLICATION, UNLESS THE DISTRIBUTOR ESTABLISHES TO THE SATISFACTION OF THE PUBLIC WORKS DIRECTOR THAT (a) THERE IS INSUFFICIENT ROOM IN ONE NEWS RACK FOR THE PUBLICATIONS WHICH MAY BE SOLD IN ONE DAY, OR (b) IT PUBLISHES MORE THAN ONE EDITION FOR SALE AT THE SAME TIME;
  - K. ON ANY ACCESS RAMP FOR DISABLED PERSONS;
  - L. WITHIN ONE HUNDRED (100) FEET OF THE ENTRANCES TO PUBLIC GATHERING PLACES WHERE QUEUING OF PEDESTRIAN TRAFFIC MAY OCCUR;
  - M. AT ANY LOCATION WHERE VEHICULAR SIGHT DISTANCE IS IMPAIRED AS DETERMINED BY STANDARD TRAFFIC ENGINEERING PRINCIPLES.
- 6.) NO NEWS RACK SHALL EXCEED FIVE (5) FEET IN HEIGHT, THIRTY (30) INCHES IN WIDTH, OR TWO (2) FEET IN DEPTH.

NOT TO SCALE

	RECOMMENDED:  DIVISION MANAGER / DATE 1/21/14	<b>CITY OF MORENO VALLEY</b> PUBLIC WORKS DEPARTMENT - CAPITAL PROJECTS DIVISION	
	APPROVED:  PUBLIC WORKS DIRECTOR / DATE 1/29/14 CITY ENGINEER	<b>NEWS RACK INSTALLATION NOTES</b>	STANDARD PLAN <b>MVSI-116B-0</b> SHEET 2 OF 2



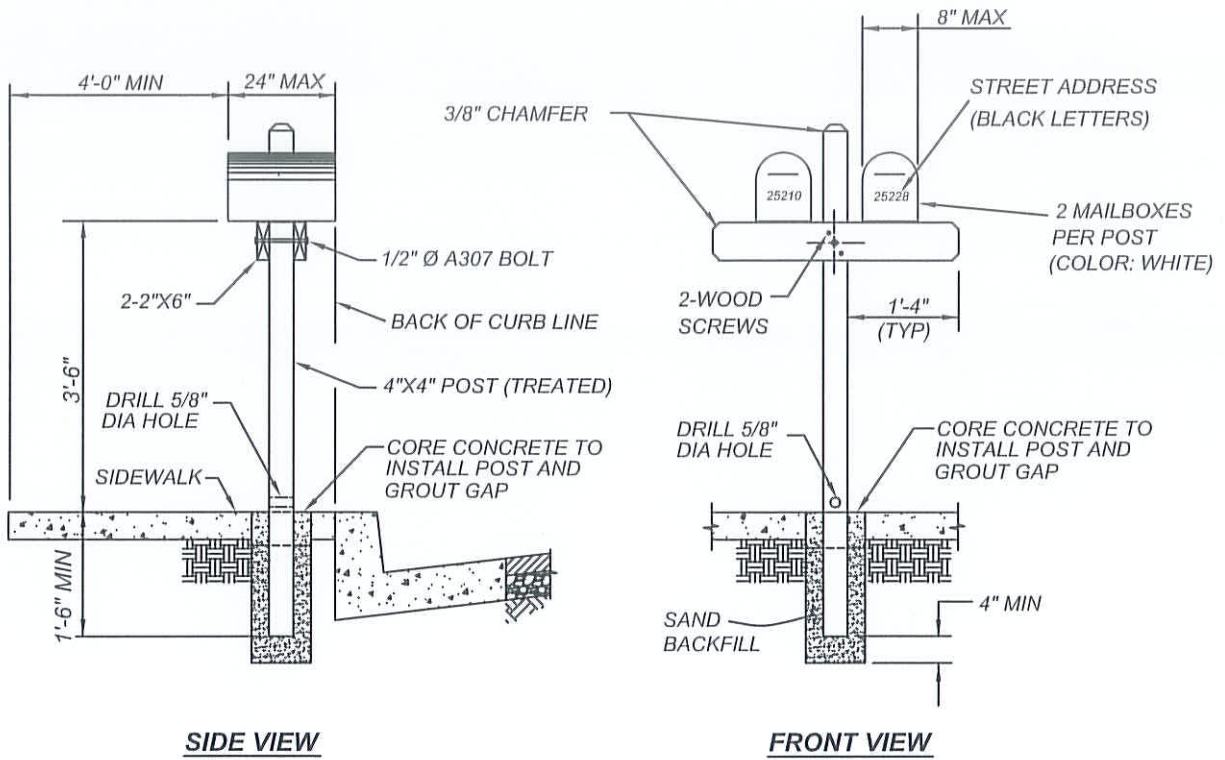



**NOTES:**

- 1.) TOP AND END OPENING MAILBOXES PERMITTED PROVIDED THAT THE FACE OF MAILBOX DOES NOT EXTEND INTO BACK OF CURB LINE. OPENING MUST FACE STREET.

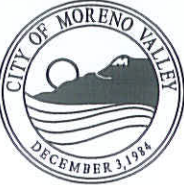
NOT TO SCALE

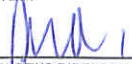
	RECOMMENDED:  DIVISION MANAGER 1/21/14 DATE	<b>CITY OF MORENO VALLEY</b> PUBLIC WORKS DEPARTMENT - CAPITAL PROJECTS DIVISION	
	APPROVED:  PUBLIC WORKS DIRECTOR / CITY ENGINEER 1/29/14 DATE	<b>SINGLE POST MAILBOX          INSTALLATION</b>	

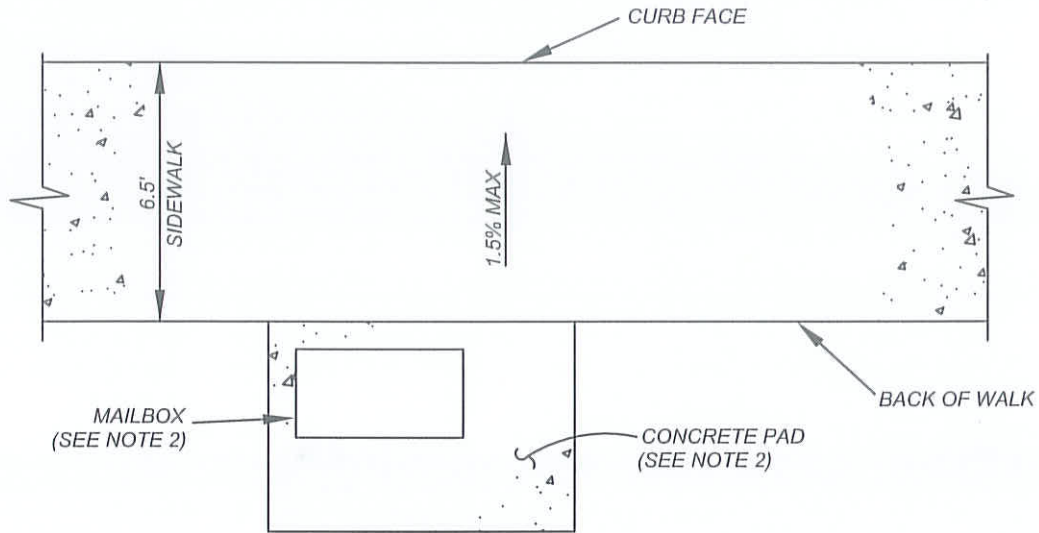

**CASE "A"**

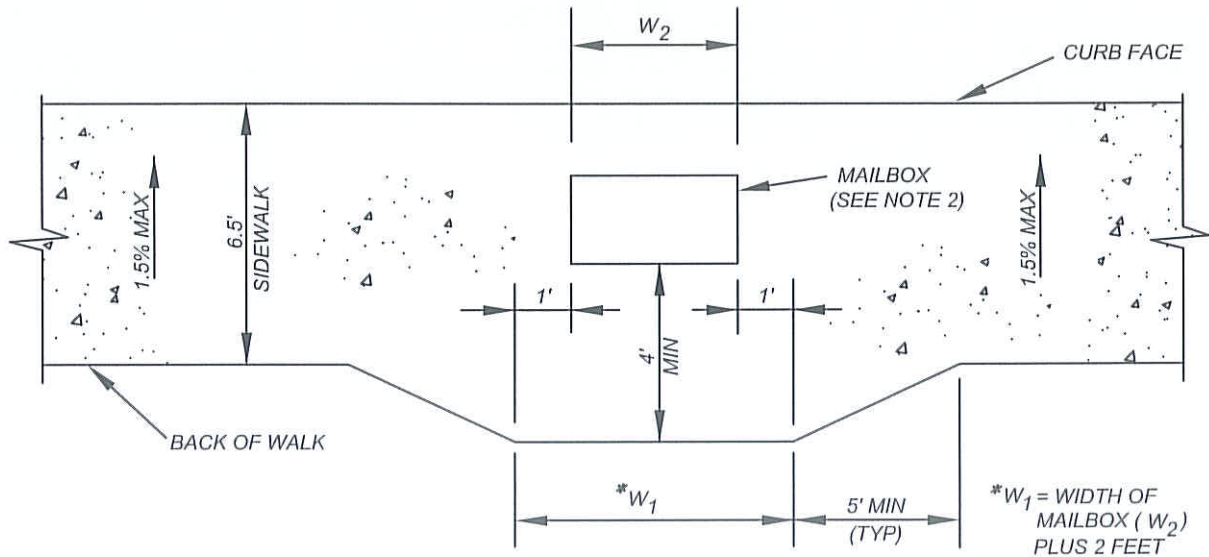

**CASE "B"**

**NOTES:**

- 1.) CASE "A" SHALL BE THE PREFERRED LOCATION FOR MAILBOX. WHEN FIELD CONDITIONS INDICATE, CASE "B" MAY BE USED.
- 2.) MAILBOX LOCATION, FOUNDATION, PAD, ANCHOR BOLTS AND BOLT HOLES SHALL CONFORM TO SPECIFICATIONS FURNISHED BY THE POSTMASTER.
- 3.) NO MAILBOXES SHALL BE LOCATED ON ARTERIAL ROADWAYS.

NOT TO SCALE

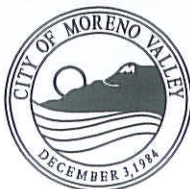

RECOMMENDED:  
  
 DIVISION MANAGER / 1/21/14 / DATE  
 APPROVED:  
  
 PUBLIC WORKS DIRECTOR / 1/29/14 / DATE  
 CITY ENGINEER

**CITY OF MORENO VALLEY**  
 PUBLIC WORKS DEPARTMENT - CAPITAL PROJECTS DIVISION

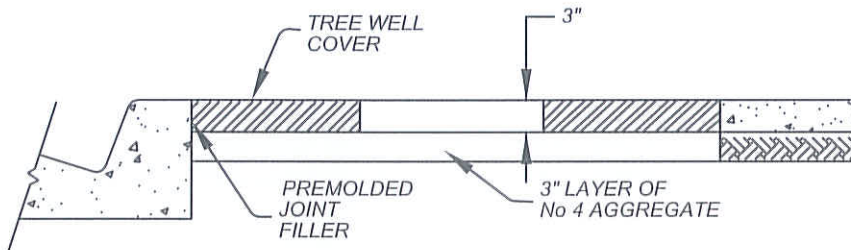
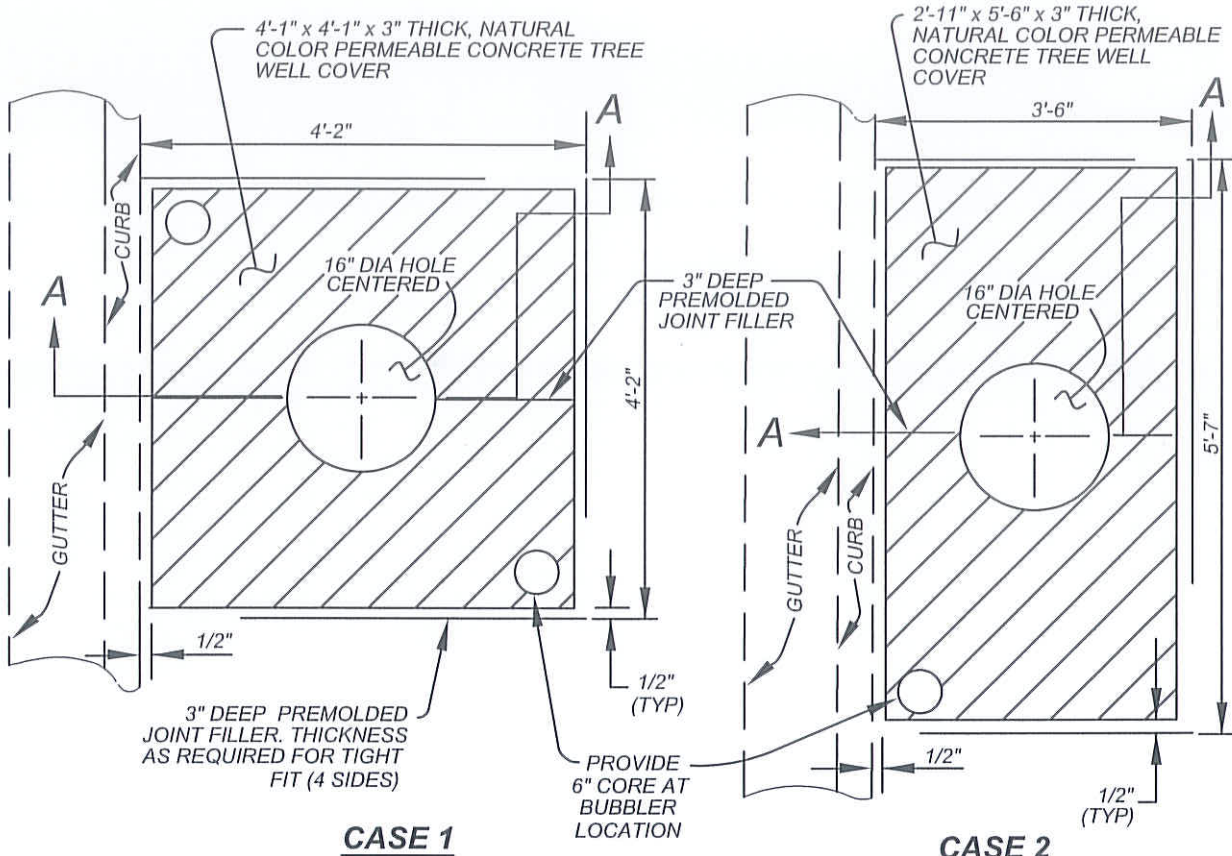

**MULTIPLE MAILBOX  
 INSTALLATION FOR  
 NEW SIDEWALK**

STANDARD PLAN  
**MVSI-117B-0**  
 SHEET 2 OF 2



**SECTION "A-A"**

NOT TO SCALE

	RECOMMENDED:  1-16-14 DIVISION MANAGER DATE	<b>CITY OF MORENO VALLEY</b> FINANCIAL & MANAGEMENT SERVICES DEPARTMENT - SPECIAL DISTRICTS DIVISION	
	APPROVED:  1/29/14 PUBLIC WORKS DIRECTOR / DATE CITY ENGINEER	<b>TREE WELL - TYPE 1</b>	



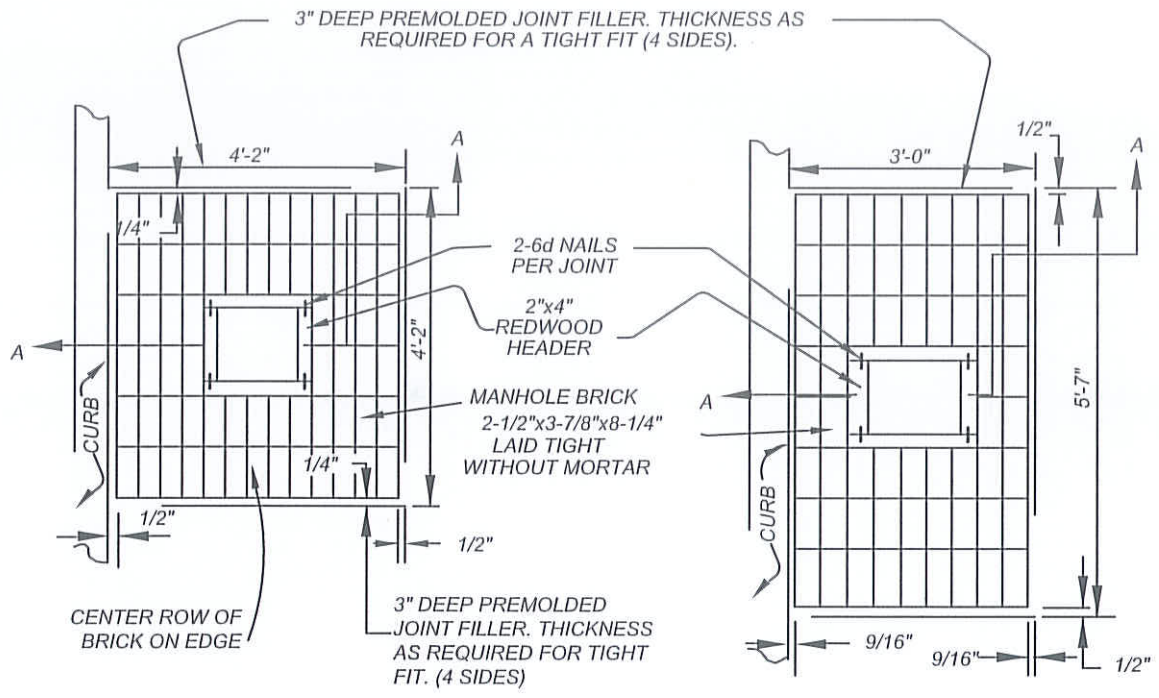

**CASE 1**

**CASE 2**

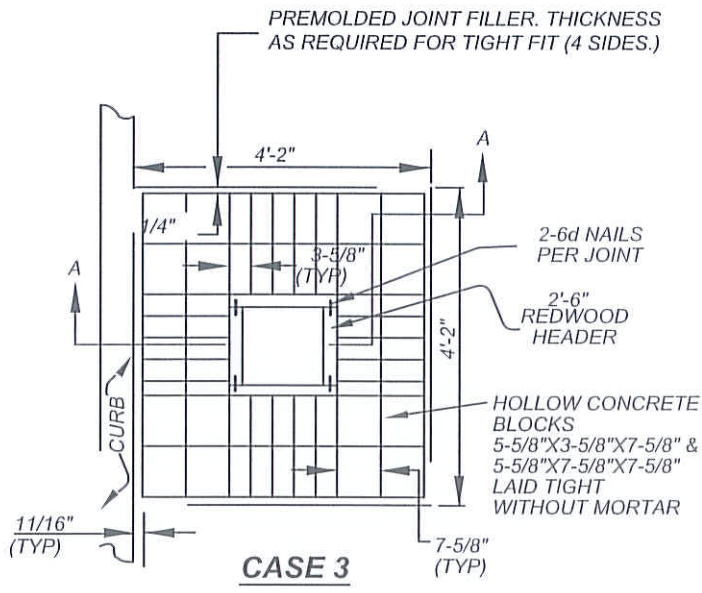

**CASE 3**

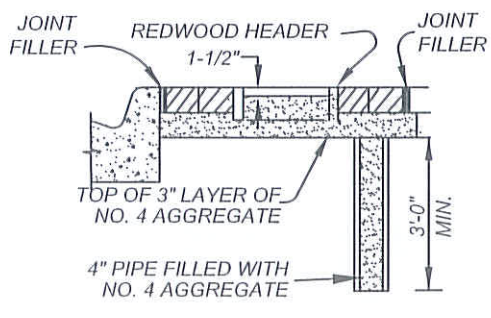

**SECTION "A-A"**

NOT TO SCALE

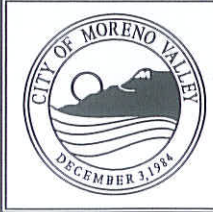

RECOMMENDED: *CS* 1/4/14  
 DIVISION MANAGER DATE  
 APPROVED: *[Signature]* 1/29/14  
 PUBLIC WORKS DIRECTOR / DATE  
 CITY ENGINEER

**CITY OF MORENO VALLEY**  
 FINANCIAL & MANAGEMENT SERVICES DEPARTMENT - SPECIAL DISTRICTS DIVISION

**TREE WELL - TYPE 2**

STANDARD PLAN  
**MVSI-118B-0**

SHEET 2 OF 5

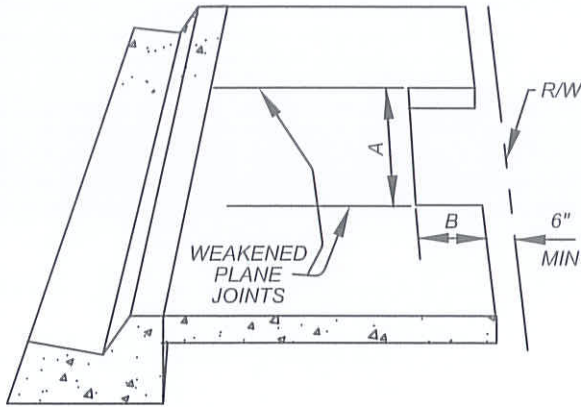

**PARKWAYS LESS THAN 8'**

CASE 1: 1'-6" x 3' TREE WELL  
 CASE 2: 2'-4" TREE WELL

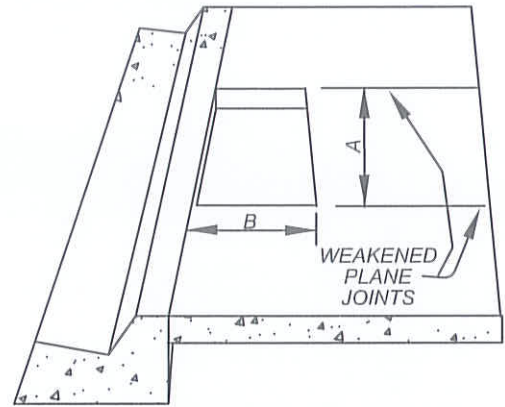

**PARKWAYS 8' OR GREATER**  
**2 COVERS REQUIRED**

CASE 3: 3'-3" TREE WELL  
 CASE 4: 4'-4" TREE WELL

**TREE WELLS**

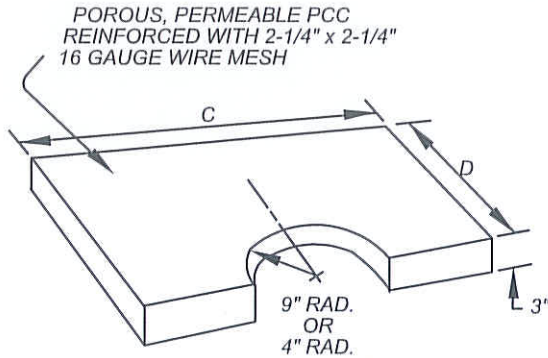

**POROUS TREE WELL COVER**

CASE	A	B	C	D
1	3'-0"	1'-6"	2'-11"	1'-5 1/2"
2	4'-0"	2'-0"	3'-11"	1'-11 1/2"
3	3'-0"	3'-0"	2'-11"	1'-5 1/2"
4	4'-0"	4'-0"	3'-11"	1'-11 1/2"

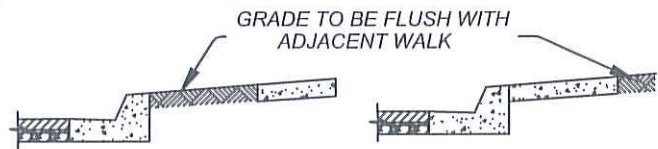



**TYPICAL SECTIONS**

**NOTES:**

- 1.) TREE WELLS SHALL BE SPACED AS DIRECTED BY THE CITY ENGINEER OR INDICATED ON THE CONTRACT DOCUMENTS.
- 2.) LOCATION OF TREES WILL BE SUBJECT TO THE FOLLOWING CONDITIONS:
  - A. MIN. 25' FROM CURB RETURNS.
  - B. MIN. 15' FROM LIGHT STANDARDS.
  - C. MIN. 5' FROM FIRE HYDRANTS
  - D. MIN. 5' FROM DRIVEWAYS (PER STD. MVSI-119-0).
- 3.) COVERS ARE TO BE COLORED BUFF USING AN ACCEPTABLE COLORING AGENT.
- 4.) TREE WELLS ARE TO BE BACKFILLED WITH CLEAN DIRT AND FLUSH WITH ADJACENT WALK UNTIL TREES ARE PLANTED.
- 5.) PARKWAYS LESS THAN 8':
  - CASE 1-UNLESS OTHERWISE SPECIFIED.
  - CASE 2-USE WHERE THERE IS AN EXISTING FENCE OR WALL AT THE PROPERTY LINE.
  - CASE 3-UNLESS OTHERWISE SPECIFIED.
  - CASE 4-MAY BE SPECIFIED WITH WALKS 7' OR GREATER.

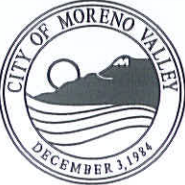
NOT TO SCALE

	RECOMMENDED:  1.16.14 DIVISION MANAGER DATE	<b>CITY OF MORENO VALLEY</b> FINANCIAL & MANAGEMENT SERVICES DEPARTMENT - SPECIAL DISTRICTS DIVISION	STANDARD PLAN <b>MVSI-118C-0</b>
	APPROVED:  1/29/14 PUBLIC WORKS DIRECTOR / DATE CITY ENGINEER	<b>TREE WELL - TYPE 3</b>	



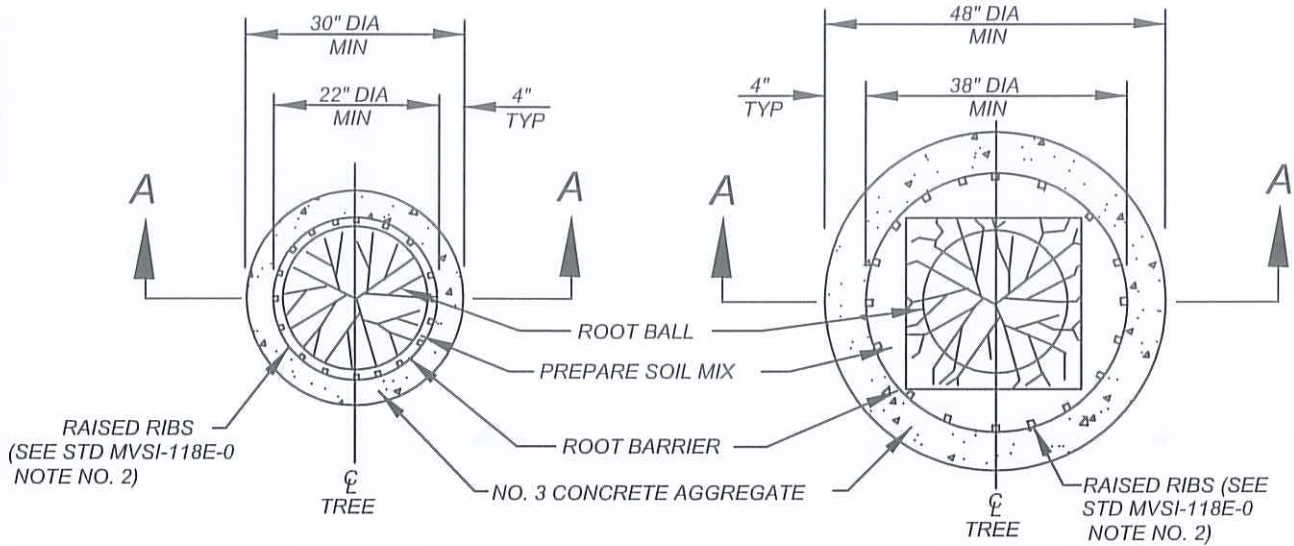

**CASE 2**

(15 GALLON SIZE OR LESS)

**CASE 1**

(BOXED TREE 24" SIZE OR LESS)

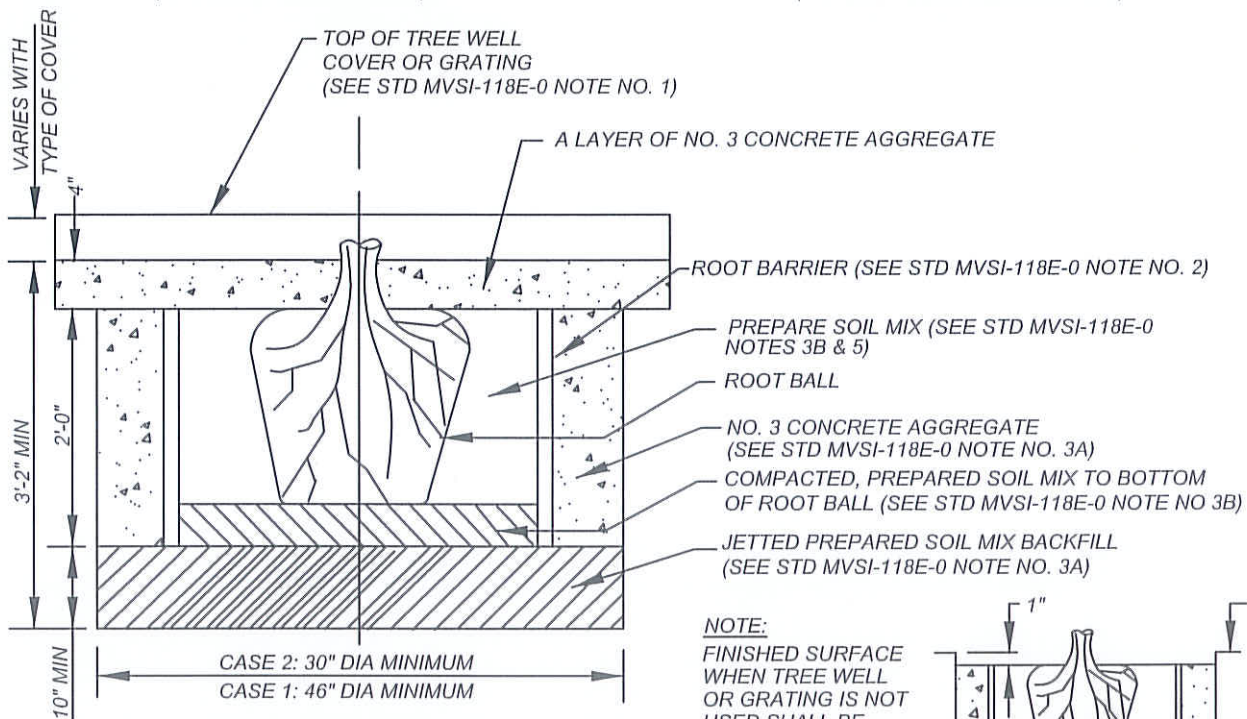

**SECTION "A-A"**

**NOTE:**  
FINISHED SURFACE  
WHEN TREE WELL  
OR GRATING IS NOT  
USED SHALL BE  
AS SHOWN AT RIGHT

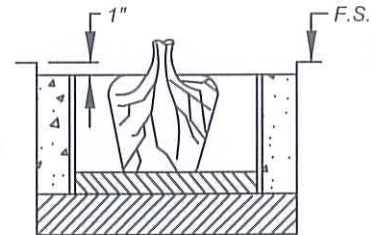

NOT TO SCALE

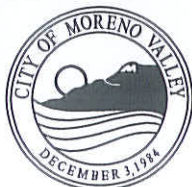

RECOMMENDED:  
*LOS 1-16-74*  
DIVISION MANAGER DATE  
APPROVED:  
*[Signature]* 1/29/74  
PUBLIC WORKS DIRECTOR DATE  
CITY ENGINEER

**CITY OF MORENO VALLEY**  
FINANCIAL & MANAGEMENT SERVICES DEPARTMENT - SPECIAL DISTRICTS DIVISION

**TREE WELL - TYPE 4**

STANDARD PLAN  
**MVSI-118D-0**



SHEET 4 OF 5



**NOTES:**

- 1.) SEE PROJECT PLANS FOR TYPE OF TREE WELL COVER OR TREE GUARD AND GRATING TO BE USED.
- 2.) ROOT BARRIER SHALL BE FABRICATED FROM A HIGH DENSITY AND HIGH IMPACT PLASTIC SUCH AS POLYVINYL CHLORIDE, ABS OR POLYETHYLENE AND HAVE A MINIMUM THICKNESS OF 0.6 INCH. THE PLASTIC SHALL HAVE ½" HIGH RAISED VERTICAL RIBS ON THE INNER SURFACE SPACED NOT MORE THAN 6" APART. INSTALLATION PER MANUFACTURER'S PRINTED INSTRUCTIONS.
- 3.) PLANTING SHALL CONFORM TO SUBSECTION 308-4 OF THE STANDARD SPECIFICATIONS FOR PUBLIC WORKS CONSTRUCTION, EXCEPT THAT:
  - A. THE LOWER 10" OF THE EXCAVATION SHALL BE BACKFILLED WITH PREPARED SOIL MIX AND JETTED PRIOR TO PLACING THE ROOT BARRIER AND THE NO. 3 CONCRETE AGGREGATE.
  - B. PREPARED SOIL MIX SHALL BE PLACED IN THE PLANTING HOLE AND COMPACTED TO BOTTOM OF ROOT BALL ELEVATION PRIOR TO PROCEEDING WITH TREE PLANTING.
- 4.) AFTER PLANTING, EACH TREE SHALL BE WATERED IMMEDIATELY WITH A MINIMUM OF 20 GALLONS OF WATER. REPEAT THE WATERING TWICE IN THE NEXT 3 DAYS, AT NO CLOSER THAN 24 HOUR INTERVALS.
- 5.) AFTER THE TREE HAS BEEN WATERED FOR THREE DAYS, ALLOW THE SOIL TO DRY SUFFICIENTLY, THEN TAMP AND GRADE THE SOIL. PLACE AND GRADE THE LAYER OF CONCRETE AGGREGATE IN ORDER TO SET THE TREE WELL COVER OR GRATING FIRMLY AND FLUSH WITH THE TOP OF THE SIDEWALK OR CURB.

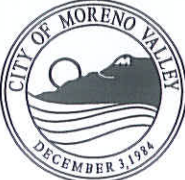
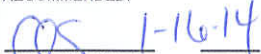
NOT TO SCALE

	RECOMMENDED:  DIVISION MANAGER      DATE	<b>CITY OF MORENO VALLEY</b> FINANCIAL & MANAGEMENT SERVICES DEPARTMENT - SPECIAL DISTRICTS DIVISION	STANDARD PLAN <b>MVSI-118E-0</b>
	APPROVED:  PUBLIC WORKS DIRECTOR / CITY ENGINEER      DATE	<b>TREE WELL NOTES</b>	SHEET 5 OF 5

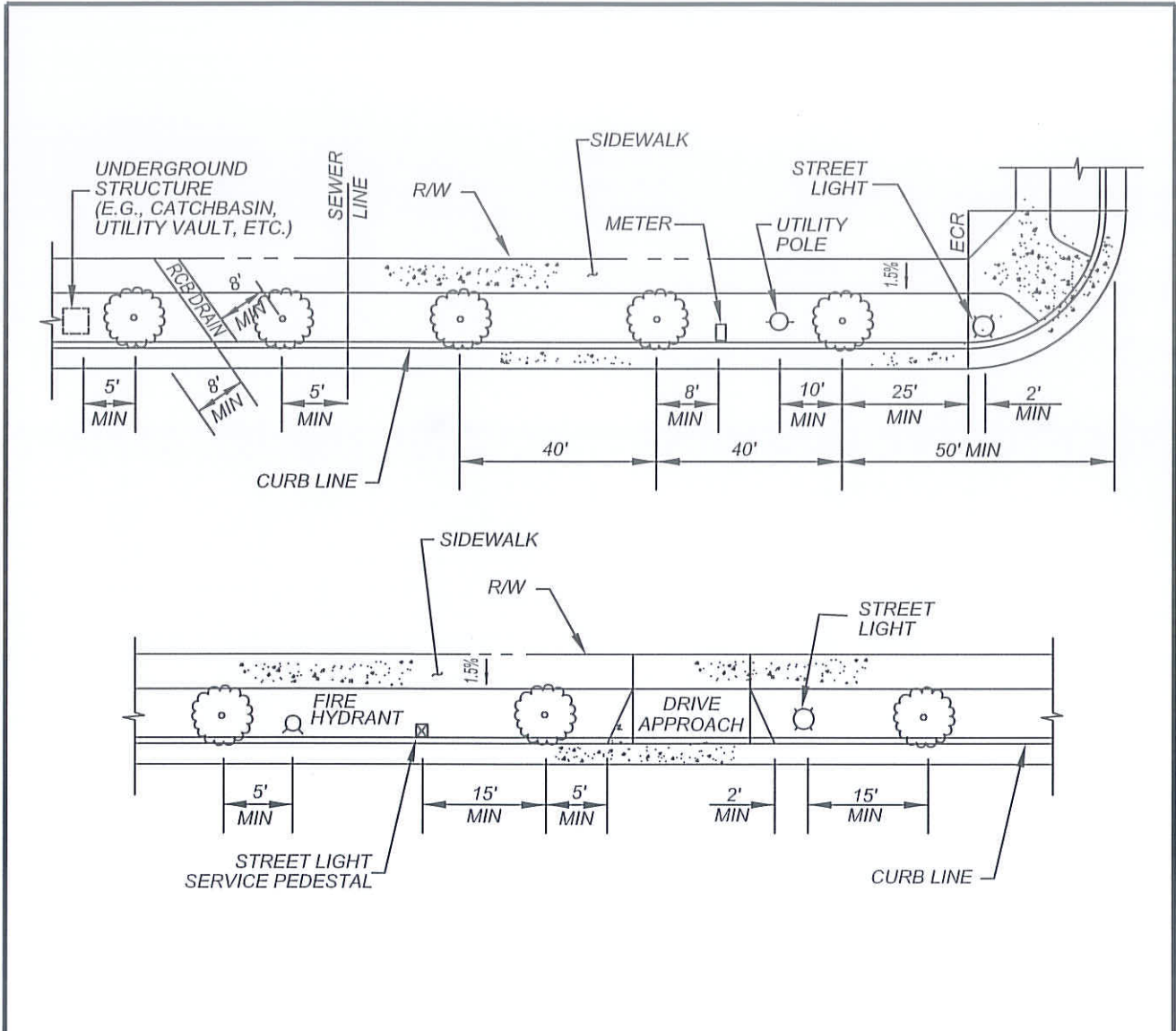

**NOTES:**

- 1.) DRIVE APPROACHES SHALL NOT BE LOCATED OVER SEWER OR WATER LATERALS.
- 2.) WATER METERS AND STREET LIGHTS SHALL BE A MINIMUM OF 2' FROM DRIVE APPROACHES.
- 3.) FIRE HYDRANTS SHALL BE A MINIMUM OF 5' FROM DRIVE APPROACHES.
- 4.) ALTERNATE LOCATION AND SPACING MAY BE REQUIRED BY CITY ENGINEER TO PROVIDE FOR SIGHT CLEARANCE OR OTHER SAFETY CONCERNS.

NOT TO SCALE

	RECOMMENDED:  DIVISION MANAGER / DATE 1/21/19	<b>CITY OF MORENO VALLEY</b> PUBLIC WORKS DEPARTMENT - CAPITAL PROJECTS DIVISION	STANDARD PLAN <b>MVSI-119-0</b>
	APPROVED:  PUBLIC WORKS DIRECTOR / CITY ENGINEER / DATE 1/29/19	<b>PARKWAY IMPROVEMENT SPACING</b>	SHEET 1 OF 1

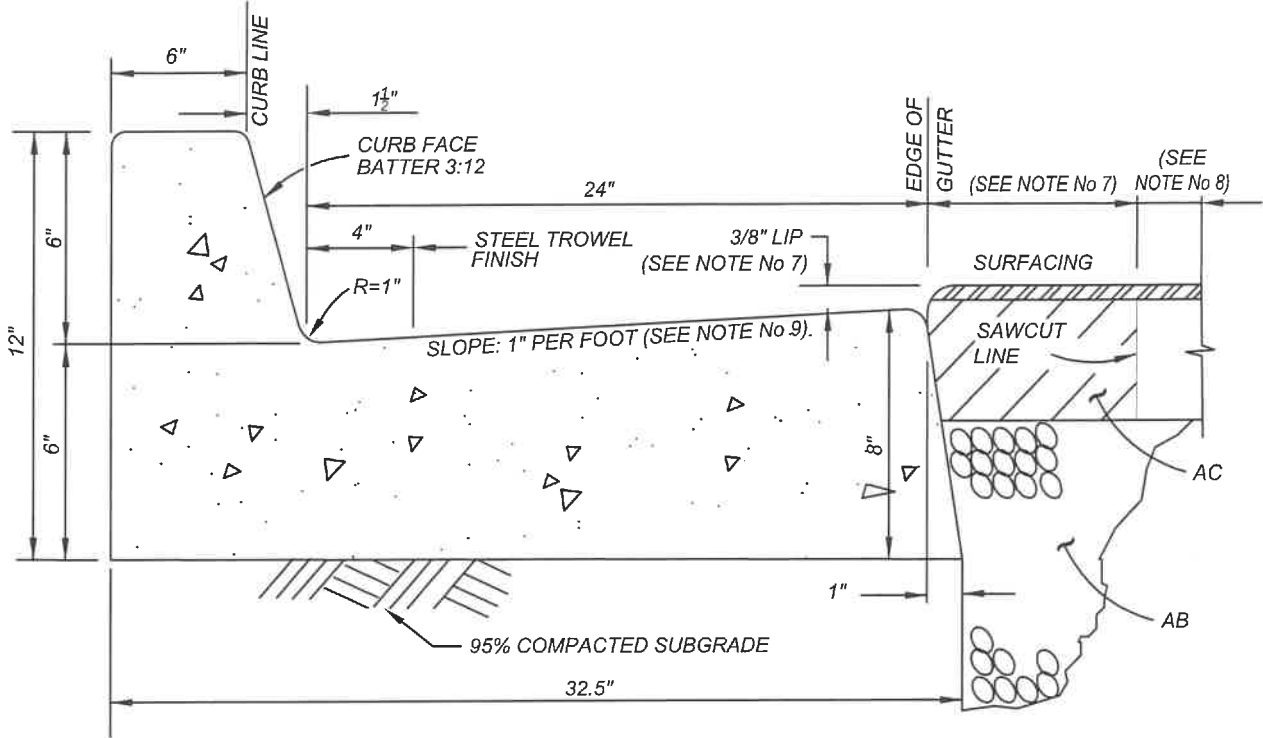

**NOTES:**

- 1.) CONCRETE SHALL BE CLASS 560-C-3250 PCC, CURED WITH WHITE PIGMENTED CURING COMPOUND.
- 2.) ALL EXPOSED CORNERS SHALL BE FINISHED WITH 1/2" RADIUS UNLESS OTHERWISE STATED.
- 3.) CURB FINISH SHALL BE FINE BROOM, GUTTER FINISH SHALL BE ROUGH.
- 4.) EXISTING PCC SHALL BE SAWCUT AT WEAKENED PLANE JOINT PRIOR TO REMOVAL.
- 5.) CURBS SHALL HAVE WEAKENED PLANE JOINTS AT 10' INTERVALS; NO SCORE LINES ALLOWED.
- 6.) WHEN CURB AND GUTTER IS PLACED BY AN EXTRUSION MACHINE, FINISHING WORK SHALL PROVIDE AN ACCEPTABLE FINISH AND WEAKENED PLANE JOINTS MAY BE SAWCUT.
- 7.) A MINIMUM 1' WIDE AC PAVEMENT REPAIR PATCH IS REQUIRED WHEN CURB AND GUTTER IS PLACED ADJACENT TO EXISTING AC PAVEMENT. PAVEMENT SURFACE NEAR BOTTOM OF ACCESS RAMP SHALL BE FLUSH WITH EDGE OF GUTTER (NO LIP) AND PAVEMENT SLOPE SHALL NOT EXCEED 5% IN ANY DIRECTION. REFER TO STDS MVSİ-114A AND MVSİ-114B FOR REQUIREMENTS.
- 8.) A MINIMUM 1' WIDE GRIND/COLDMILL 0.10' DEEP SLOT OR AS DIRECTED BY THE CITY ENGINEER. SEE STD MVSİ-132B FOR FINISH OVERLAY REQUIREMENTS.
- 9.) GUTTER SLOPE NEAR BOTTOM OF ACCESS RAMP SHALL NOT EXCEED 5% (HIKE = 1.2" MAX) REFER TO STDS MVSİ-114A AND MVSİ-114B FOR REQUIREMENTS.

NOT TO SCALE

	RECOMMENDED: <i>Harvey</i> 7/16/19 DIVISION MANAGER DATE	<b>CITY OF MORENO VALLEY</b> PUBLIC WORKS DEPARTMENT - CAPITAL PROJECTS DIVISION	
	APPROVED: <i>McLure</i> 10/16/19 PUBLIC WORKS DIRECTOR / DATE CITY ENGINEER	<b>TYPE 6</b> <b>INTEGRAL CURB AND GUTTER</b>	

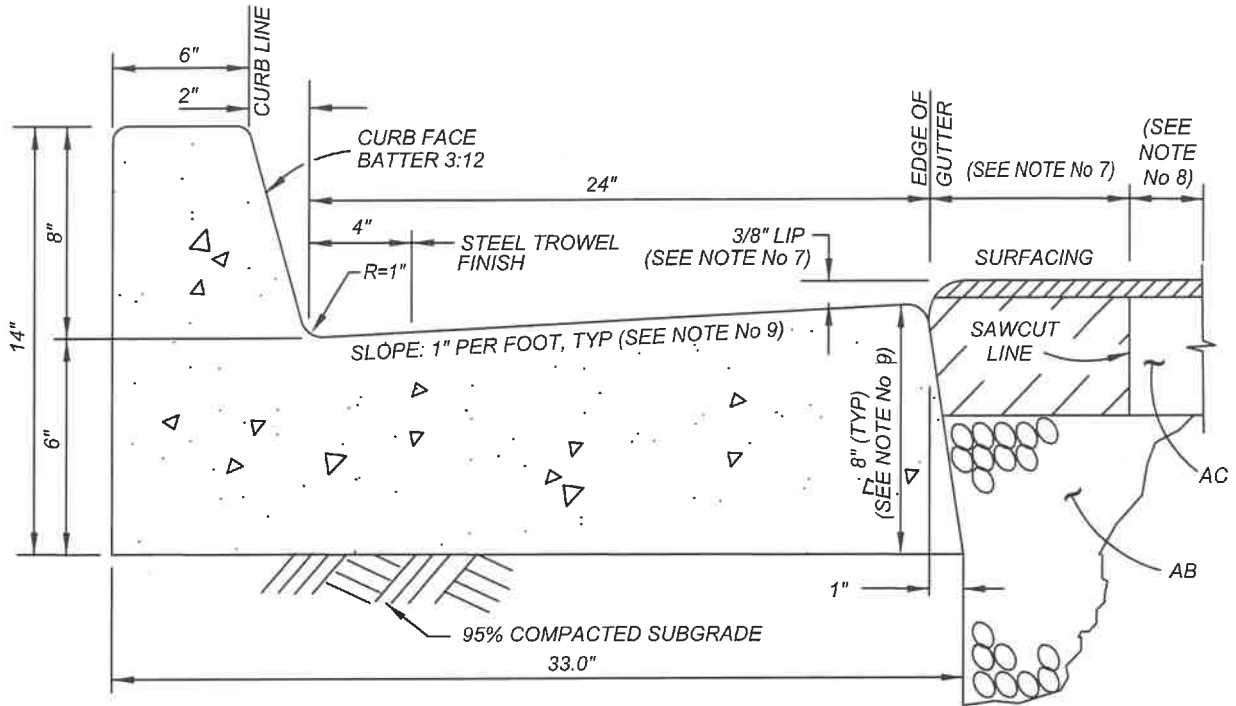

**NOTES:**

- 1.) CONCRETE SHALL BE CLASS 560-C-3250 PCC, CURED WITH WHITE PIGMENTED CURING COMPOUND.
- 2.) ALL EXPOSED CORNERS SHALL BE FINISHED WITH  $\frac{1}{2}$ " RADIUS UNLESS OTHERWISE STATED.
- 3.) CURB FINISH SHALL BE FINE BROOM, GUTTER FINISH SHALL BE ROUGH.
- 4.) EXISTING PCC SHALL BE SAWCUT AT WEAKENED PLANE JOINT PRIOR TO REMOVAL.
- 5.) CURBS SHALL HAVE WEAKENED PLANE JOINTS AT 10' INTERVALS; NO SCORE LINES ALLOWED.
- 6.) WHEN CURB AND GUTTER IS PLACED BY AN EXTRUSION MACHINE, FINISHING WORK SHALL PROVIDE AN ACCEPTABLE FINISH AND WEAKENED PLANE JOINTS MAY BE SAWCUT.
- 7.) A MINIMUM 1' WIDE AC PAVEMENT REPAIR PATCH IS REQUIRED WHEN CURB AND GUTTER IS PLACED ADJACENT TO EXISTING AC PAVEMENT. PAVEMENT SURFACE NEAR BOTTOM OF ACCESS RAMP SHALL BE FLUSH WITH EDGE OF GUTTER (NO LIP) AND PAVEMENT SLOPE SHALL NOT EXCEED 5% IN DIRECTION OF TRAVEL FOR WHEELCHAIRS. REFER TO STDS MVSI-114A AND MVSI-114B FOR REQUIREMENTS.
- 8.) A MINIMUM 1' WIDE GRIND/COLDMILL 0.10' DEEP SLOT OR AS DIRECTED BY THE CITY ENGINEER. SEE STD MVSI-132B FOR FINISH OVERLAY REQUIREMENTS.
- 9.) GUTTER SLOPE NEAR BOTTOM OF ACCESS RAMP SHALL NOT EXCEED 5% (HIKE = 1.2" MAX) REFER TO STDS MVSI-114A AND MVSI-114B FOR REQUIREMENTS.

NOT TO SCALE

	RECOMMENDED: <i>Harvey</i> 7/16/19 DIVISION MANAGER DATE	<b>CITY OF MORENO VALLEY</b> PUBLIC WORKS DEPARTMENT - CAPITAL PROJECTS DIVISION	
	APPROVED: <i>ML Wong</i> 10/16/19 PUBLIC WORKS DIRECTOR / DATE CITY ENGINEER	<b>TYPE 8</b> <b>INTEGRAL CURB AND GUTTER</b>	

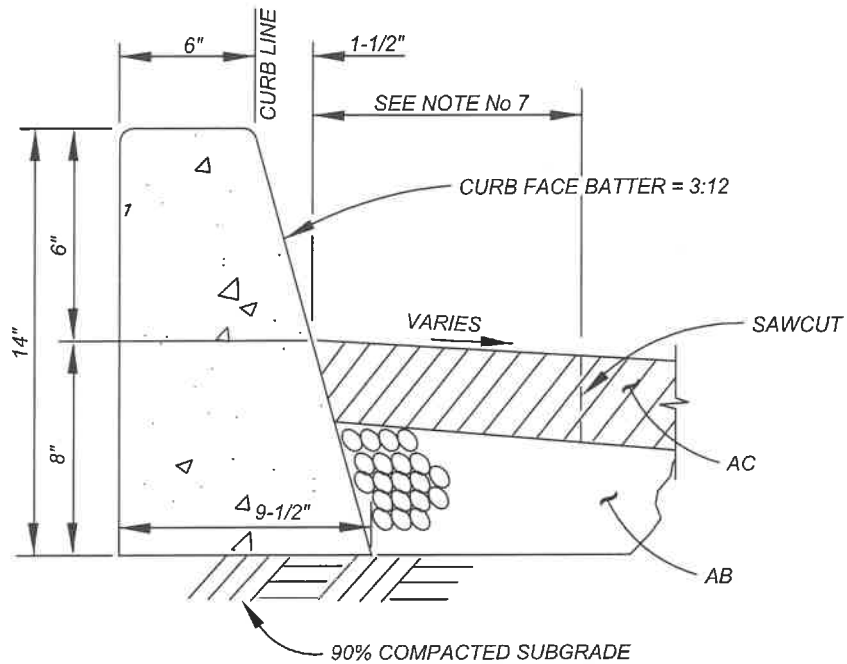

**NOTES:**

- 1.) CONCRETE SHALL BE CLASS 560-C-3250 PCC, CURED WITH WHITE PIGMENTED CURING COMPOUND.
- 2.) ALL EXPOSED CORNERS SHALL BE FINISHED WITH  $\frac{1}{2}$ " RADIUS.
- 3.) FINISH SHALL BE FINE BROOM.
- 4.) EXISTING PCC SHALL BE SAWCUT AT JOINT PRIOR TO REMOVAL.
- 5.) WEAKENED PLANE JOINTS AT 10' INTERVALS.
- 6.) WHEN CURB AND GUTTER IS PLACED BY AN EXTRUSION MACHINE, FINISHING WORK SHALL PROVIDE AN ACCEPTABLE FINISH AND WEAKENED PLANE JOINTS MAY BE SAWCUT.
- 7.) MINIMUM 1' WIDE AC PAVEMENT REPAIR PATCH IS REQUIRED WHEN CURB AND GUTTER IS PLACED ADJACENT TO EXISTING AC PAVEMENT.

NOT TO SCALE

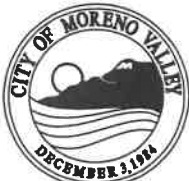
	RECOMMENDED: <i>Hanrygo</i> 7/16/19 DIVISION MANAGER DATE	<b>CITY OF MORENO VALLEY</b> PUBLIC WORKS DEPARTMENT - CAPITAL PROJECTS DIVISION	
	APPROVED: <i>M. L. ...</i> 12/15/19 PUBLIC WORKS DIRECTOR / DATE CITY ENGINEER	<b>TYPE 6A CURB</b>	

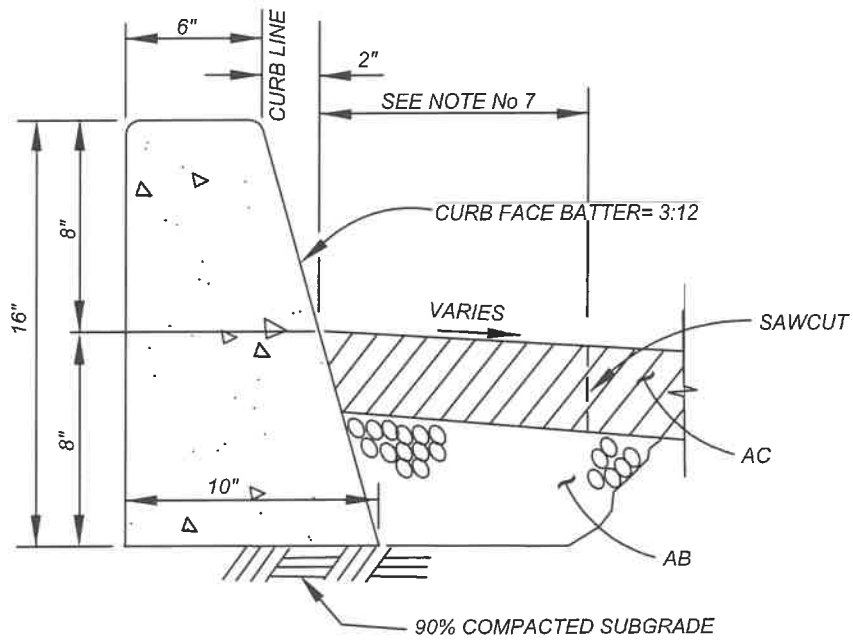

**NOTES:**

- 1.) CONCRETE SHALL BE CLASS 560-C-3250 PCC, CURED WITH WHITE PIGMENTED CURING COMPOUND.
- 2.) ALL EXPOSED CORNERS SHALL BE FINISHED WITH  $\frac{1}{2}$ " RADIUS.
- 3.) FINISH SHALL BE FINE BROOM.
- 4.) EXISTING PCC SHALL BE SAWCUT AT JOINT PRIOR TO REMOVAL.
- 5.) WEAKENED PLANE JOINTS AT 10' INTERVALS.
- 6.) WHEN CURB AND GUTTER IS PLACED BY AN EXTRUSION MACHINE, FINISHING WORK SHALL PROVIDE AN ACCEPTABLE FINISH AND WEAKENED PLANE JOINTS MAY BE SAWCUT.
- 7.) MINIMUM 1' WIDE AC PAVEMENT REPAIR PATCH IS REQUIRED WHEN CURB AND GUTTER IS PLACED ADJACENT TO EXISTING AC PAVEMENT.

NOT TO SCALE

	RECOMMENDED: <i>Henry</i> 7/16/14 DIVISION MANAGER DATE	<b>CITY OF MORENO VALLEY</b> PUBLIC WORKS DEPARTMENT - CAPITAL PROJECTS DIVISION	
	APPROVED: <i>M. Lopez</i> 10/16/14 PUBLIC WORKS DIRECTOR / DATE CITY ENGINEER	<b>TYPE 8A CURB</b>	STANDARD PLAN <b>MVSI-121B-0</b> SHEET 2 OF 2



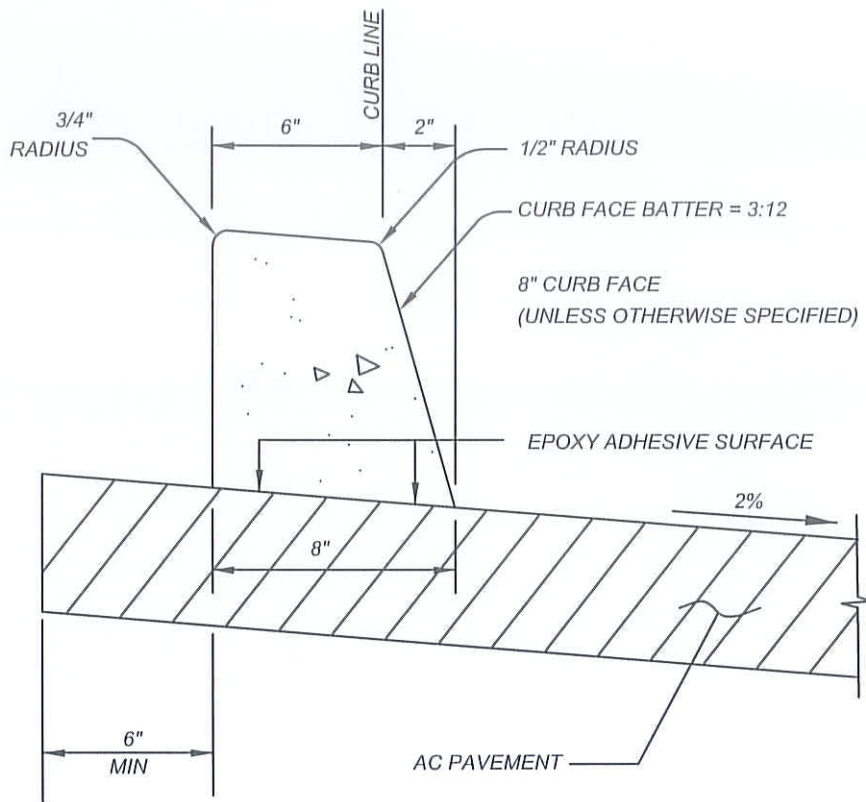



**NOTES:**

- 1.) CONCRETE SHALL BE CLASS 560-C-3250 PCC, CURED WITH WHITE PIGMENTED CURING COMPOUND.
- 2.) ALL EXPOSED CORNERS SHALL BE FINISHED WITH  $\frac{1}{2}$ " RADIUS UNLESS OTHERWISE STATED.
- 3.) FINISH SHALL BE FINE BROOM.
- 4.) EXISTING PCC SHALL BE SAWCUT AT JOINT PRIOR TO REMOVAL.
- 5.) CURBS SHALL HAVE EXPANSION JOINTS AT BCR AND ECR AND WEAKENED PLANE JOINTS AT 10' INTERVALS ONLY.
- 6.) WHEN CURB AND GUTTER IS PLACED BY AN EXTRUSION MACHINE, FINISHING WORK SHALL PROVIDE AN ACCEPTABLE FINISH AND WEAKENED PLANE JOINTS MAY BE SAWCUT.

NOT TO SCALE

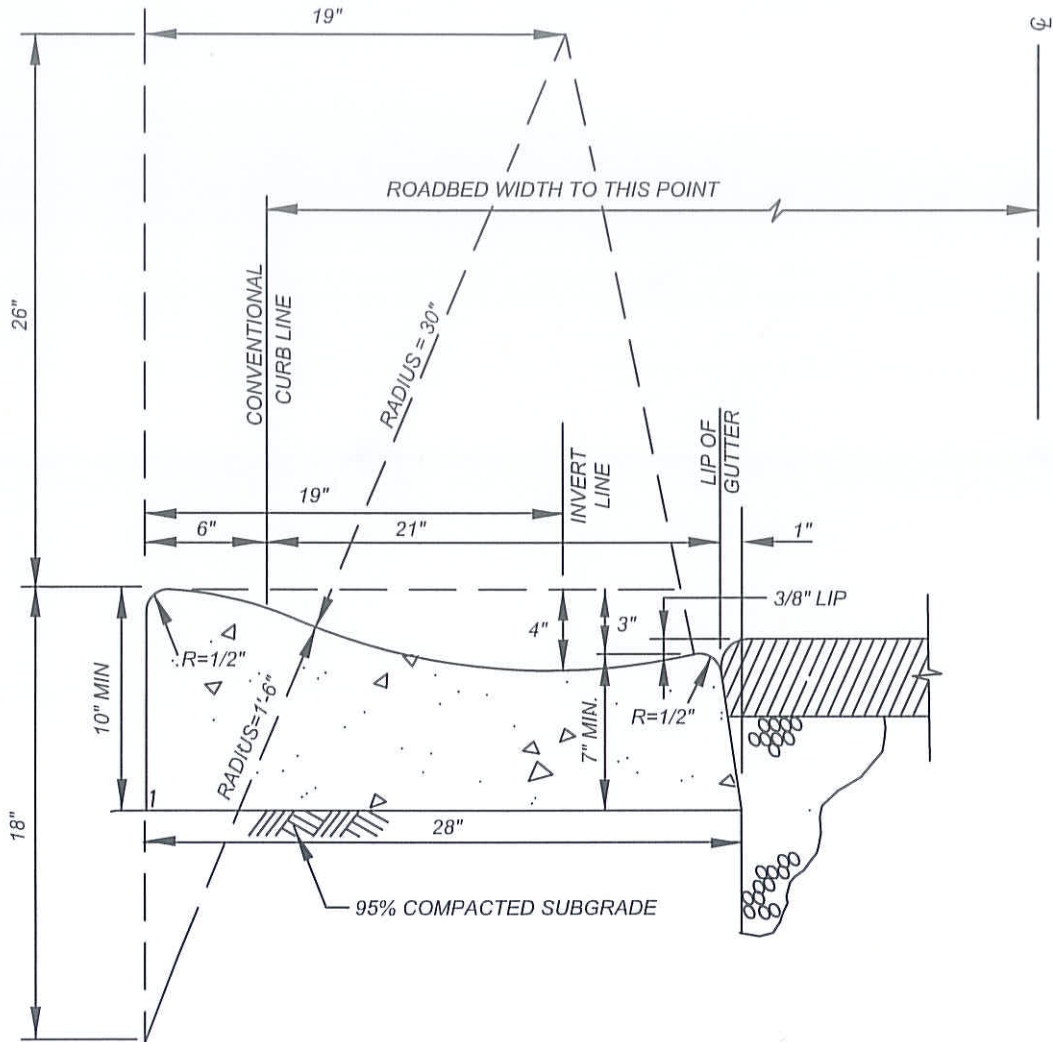

	RECOMMENDED:  DIVISION MANAGER / DATE 1/21/14	<b>CITY OF MORENO VALLEY</b> PUBLIC WORKS DEPARTMENT - CAPITAL PROJECTS DIVISION	
	APPROVED:  PUBLIC WORKS DIRECTOR / CITY ENGINEER / DATE 1/29/14	<b>TYPE D-1 CURB</b>	



**NOTES:**

- 1.) CONCRETE SHALL BE CLASS 560-C-3250 PCC, CURED WITH WHITE PIGMENTED CURING COMPOUND.
- 2.) ALL EXPOSED CORNERS SHALL BE FINISHED WITH  $\frac{1}{2}$ " RADIUS.
- 3.) FINISH SHALL BE FINE BROOM.
- 4.) EXISTING PCC SHALL BE SAWCUT AT SCORELINE PRIOR TO REMOVAL.
- 5.) CURBS SHALL HAVE EXPANSION JOINTS AT 60' INTERVALS, AND WEAKENED PLANE JOINTS AT 10' INTERVALS ONLY; NO SCORELINE ALLOWED.
- 6.) WHEN ROLLED CURB IS PLACED BY AN EXTRUSION MACHINE, FINISHING WORK SHALL PROVIDE AN ACCEPTABLE FINISH AND WEAKENED PLANE JOINTS MAY BE SAWCUT.
- 7.) ROLLED CURB MAY BE USED WITH THE APPROVAL OF THE CITY ENGINEER.

NOT TO SCALE

	RECOMMENDED:  DIVISION MANAGER DATE: 1/21/14	<b>CITY OF MORENO VALLEY</b> PUBLIC WORKS DEPARTMENT - CAPITAL PROJECTS DIVISION	STANDARD PLAN <b>MVSI-123-0</b>
	APPROVED:  PUBLIC WORKS DIRECTOR/ CITY ENGINEER DATE: 1/29/14	<b>TYPE C ROLLED CURB</b>	SHEET 1 OF 1

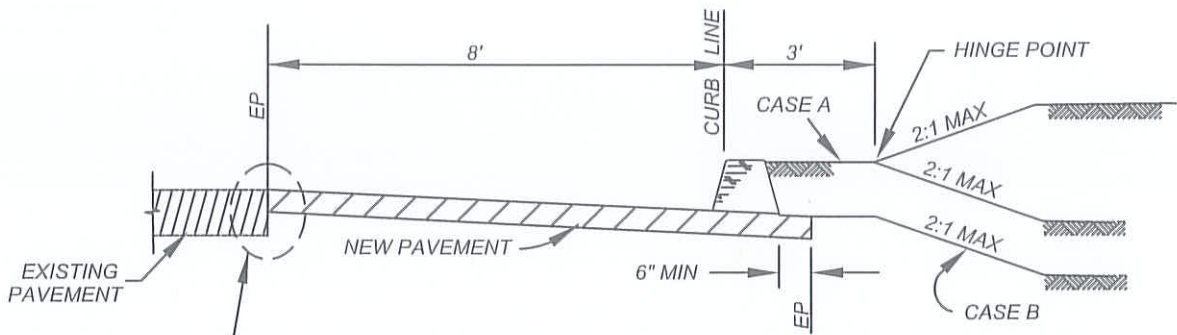

SEE STD MVS-131-0  
FOR PAVEMENT JOIN

**PAVED SHOULDER WITH AC CURB**

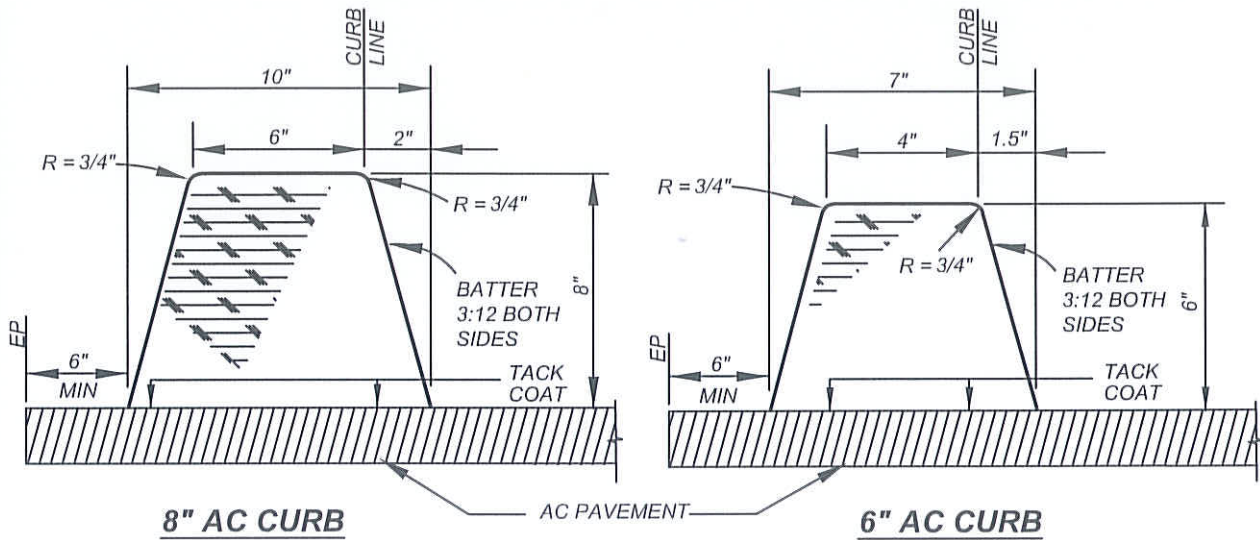



**NOTES:**

- 1.) THE ASPHALT CONCRETE MIXTURE SHALL BE TYPE III D-PG 70-10 WITH A MINIMUM ASPHALT BINDER OF 5.8 PERCENT.
- 2.) PRIOR TO PLACEMENT, A TACK COAT SHALL BE APPLIED TO THE EXISTING SURFACE. TACK COAT SHALL BE PG 64-10 AT AN APPROXIMATE RATE OF 0.05 GALLON PER SQUARE YARD OR GRADE SS-1h EMULSIFIED ASPHALT AT AN APPROXIMATE RATE OF 0.05 TO 0.10 GALLON PER SQUARE YARD.
- 3.) THE TEMPERATURE OF THE MIX AT THE TIME OF PLACEMENT SHALL NOT BE LESS THAN 250°F OR MORE THAN 285° F.
- 4.) ALL EXTRUDERS AND SHOES SHALL BE APPROVED BY THE CITY ENGINEER.
- 5.) USE CASE A BACKFILL UNLESS NOTED OTHERWISE.

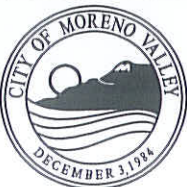
NOT TO SCALE



RECOMMENDED:  
 1/21/14  
 DIVISION MANAGER DATE  
 APPROVED:  
 1/29/14  
 PUBLIC WORKS DIRECTOR / CITY ENGINEER DATE

**CITY OF MORENO VALLEY**  
 PUBLIC WORKS DEPARTMENT - CAPITAL PROJECTS DIVISION

**ASPHALT CONCRETE CURB**

STANDARD PLAN  
**MVSI-124-0**

SHEET 1 OF 1



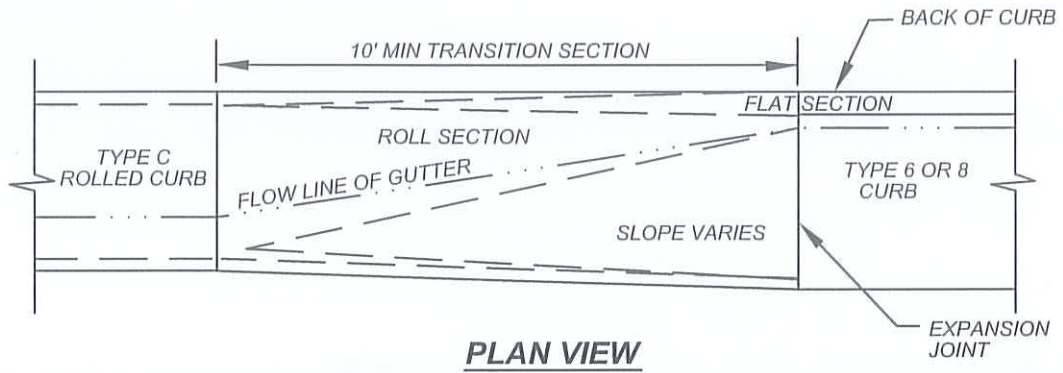

**PLAN VIEW**

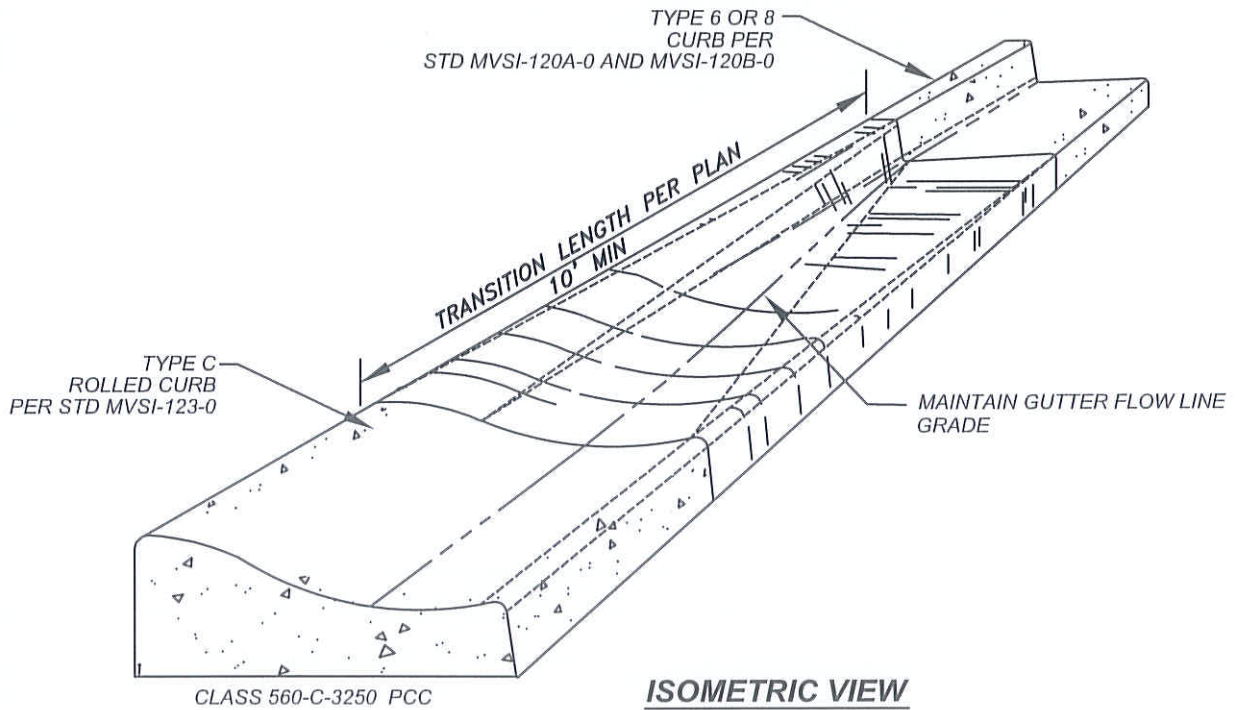

**ISOMETRIC VIEW**

**NOTE:**

TO BE USED ONLY WHEN ROLLED CURB HAS BEEN APPROVED FOR USE BY THE CITY ENGINEER PRIOR TO DESIGN.

NOT TO SCALE



	<p>RECOMMENDED:</p> <p><i>[Signature]</i> / 2/21/14          DIVISION MANAGER / DATE</p>	<p><b>CITY OF MORENO VALLEY</b>          PUBLIC WORKS DEPARTMENT - CAPITAL PROJECTS DIVISION</p>	
	<p>APPROVED:</p> <p><i>[Signature]</i> / 1/25/14          PUBLIC WORKS DIRECTOR / DATE          CITY ENGINEER</p>	<p><b>CURB TRANSITION</b></p>	



**NOTES:**

- 1.) BACKGROUND SHALL BE PAINTED WITH GOOD QUALITY HIGH GLOSS REFLECTIVE WHITE PAINT.
- 2.) NUMBERS SHALL BE PAINTED WITH GOOD QUALITY FLAT BLACK PAINT.
- 3.) NUMBERS SHALL BE CENTERED VERTICALLY WITH NO BORDERS.
- 4.) NUMBERS SHALL BE PLACED ALONG CURB FACE , 3' FROM THE TOP OF X ON THE MAIN DRIVEWAY APPROACH THAT IS CLOSEST TO THE CENTER OF THE LOT.

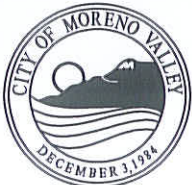
NOT TO SCALE

	RECOMMENDED:  DIVISION MANAGER / DATE 1/21/14	<b>CITY OF MORENO VALLEY</b> PUBLIC WORKS DEPARTMENT - CAPITAL PROJECTS DIVISION	
	APPROVED:  PUBLIC WORKS DIRECTOR / DATE 1/29/14 CITY ENGINEER	<b>CURB ADDRESS PAINTING</b>	



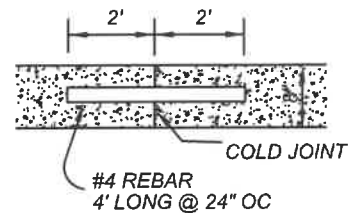
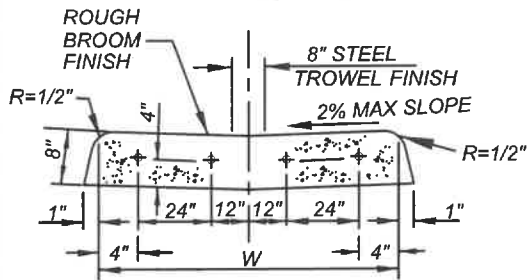
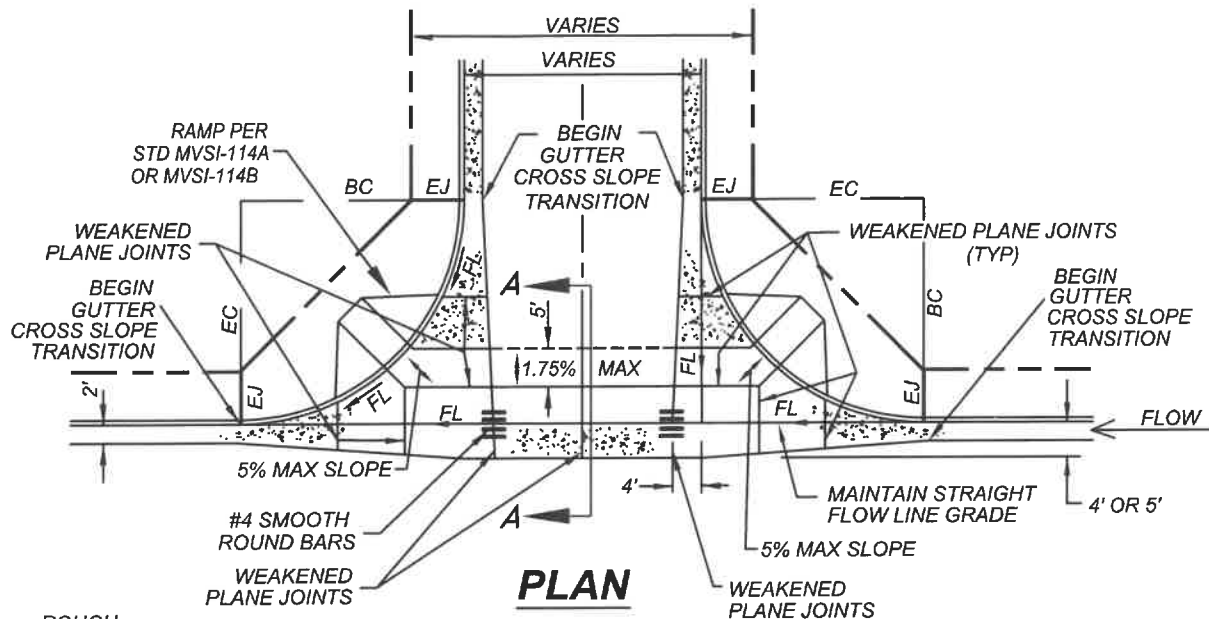

**SECTION "A-A"**  
CROSS GUTTER

**REBAR DETAIL**

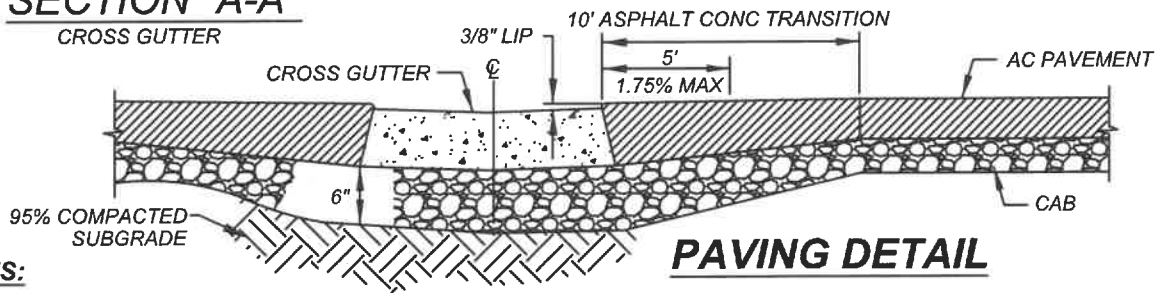

**PAVING DETAIL**

**NOTES:**

- 1.) ALL CONCRETE SHALL BE CLASS 560-C-3250, CURED WITH WHITE PIGMENTED DURING COMPOUND.
- 2.) COAT 1/2 THE LENGTH OF DOWELS WITH GREASE TO PROVIDE SLIPPAGE.
- 3.) DIMENSIONS MAY BE INCREASED DEPENDING ON DRAINAGE CONSIDERATIONS.
- 4.) 6" THICK CLASS (2) AGGREGATE BASE SHALL BE PLACED AND COMPACTED TO 95% RELATIVE COMPACTION UNDER 8" THICK CROSS GUTTER AND SPANDRELS.
- 5.) DOWELS REQUIRED WHEN CROSS GUTTER AND SPANDREL ARE POURED SEPARATELY.
- 6.) SPANDREL WEAKENED PLANE JOINT LOCATIONS WILL BE DETERMINED BY ACCESS RAMP LOCATIONS.
- 7.) A MINIMUM 1' WIDE AC PAVEMENT REPAIR PATCH IS REQUIRED WHEN CROSS GUTTER IS PLACED ADJACENT TO EXISTING AC PAVEMENT.
- 8.) THE MINIMUM DISTANCE W = 10' ON ARTERIAL STREETS, 8' ON OTHERS.

NOT TO SCALE



RECOMMENDED:  
*Honuygo* 8/14/19  
DIVISION MANAGER DATE  
APPROVED:  
*M.L. Wolf* 10/11/19  
PUBLIC WORKS DIRECTOR / DATE  
CITY ENGINEER

**CITY OF MORENO VALLEY**  
PUBLIC WORKS DEPARTMENT - CAPITAL PROJECTS DIVISION

**CROSS GUTTER  
AND SPANDREL**

STANDARD PLAN  
**MVSI-127-1**

SHEET 1 OF 1

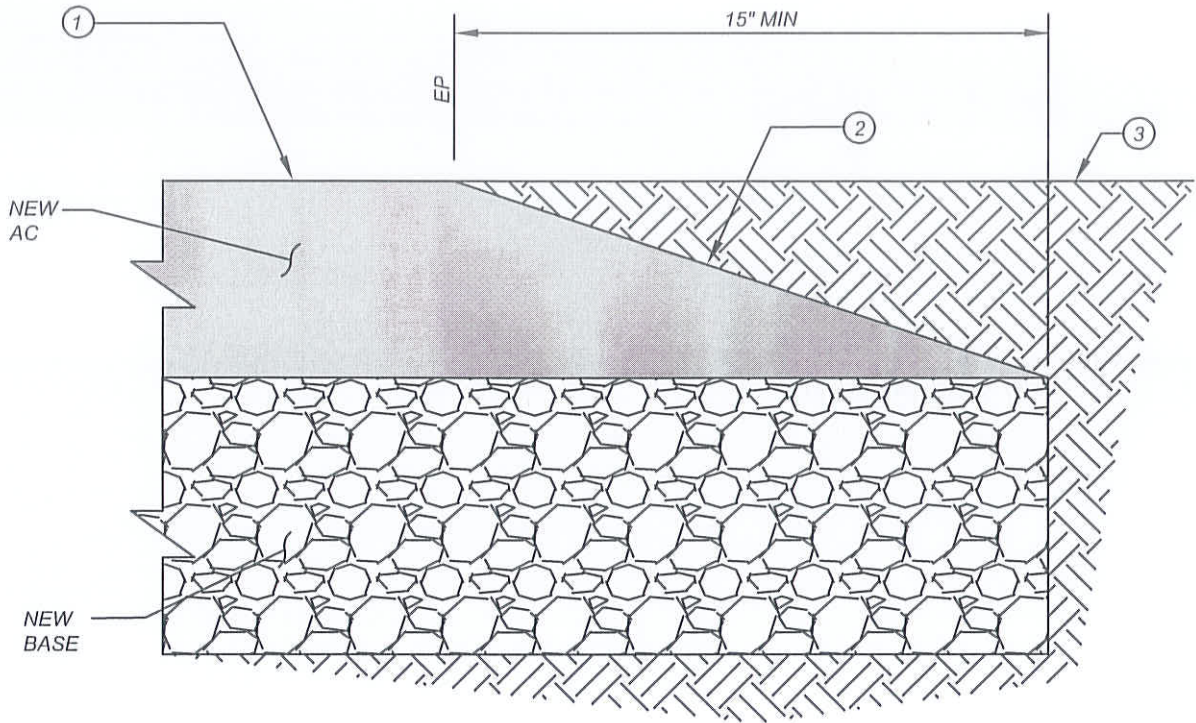



**LEGEND:**

- ① AC FINISH GRADE.
- ② 1:3 TAPERED EDGE OF PAVEMENT (1 VERTICAL : 3 HORIZONTAL).
- ③ SHOULDER FINISH GRADE.

**NOTES:**

- 1.) TAPERED EDGE OF PAVEMENT SHALL BE PLACED AT ALL EDGE OF PAVEMENT LOCATIONS WHERE CURB DOES NOT EXIST.

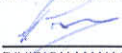
NOT TO SCALE

	RECOMMENDED:  DIVISION MANAGER      1/21/14 DATE	<h2 style="margin: 0;">CITY OF MORENO VALLEY</h2> <p style="margin: 0;">PUBLIC WORKS DEPARTMENT - CAPITAL PROJECTS DIVISION</p>	STANDARD PLAN <b>MVSI-130-0</b>
	APPROVED:  PUBLIC WORKS DIRECTOR / CITY ENGINEER      1/29/14 DATE	<h3 style="margin: 0;">PAVEMENT EDGE TAPER</h3>	SHEET 1 OF 1

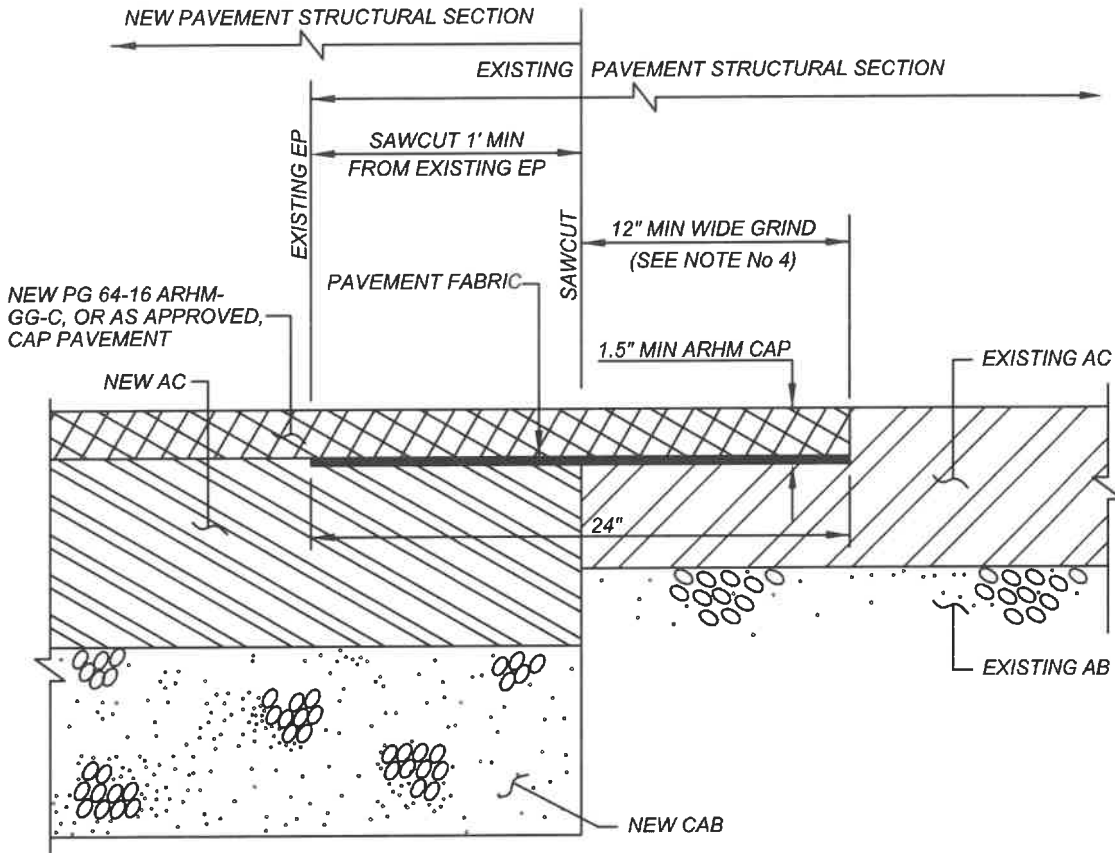

**NOTES:**

- 1.) THIS STANDARD SHALL APPLY TO PROJECTS THAT REQUIRE NEW ROADWAY WIDENING OR EXTENSION THAT ABUTS TO EXISTING ROADWAY, OR AS APPROVED BY THE CITY ENGINEER.
- 2.) THE NEW ROADWAY STRUCTURAL SECTION SHALL BE IN ACCORDANCE WITH THE PROJECT'S CITY-APPROVED GEOTECHNICAL REPORT.
- 3.) PAVEMENT FABRIC SHALL BE IN ACCORDANCE WITH THE THE LATEST VERSION OF THE "GREENBOOK" STANDARD SPECIFICATIONS FOR PUBLIC WORKS CONSTRUCTION AND/OR THE PROJECT'S CITY-APPROVED SPECIFICATIONS OR AS RECOMMENDED BY A GEOTECHNICAL ENGINEER/REGISTERED CIVIL ENGINEER AND APPROVED BY THE CITY
- 4.) NEW ARHM PAVEMENT SHALL BE EXTENDED TO BIKE LANE STRIPING OR NEAREST LANE LINES AS REQUIRED BY THE CITY ENGINEER.

NOT TO SCALE

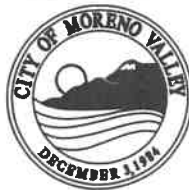

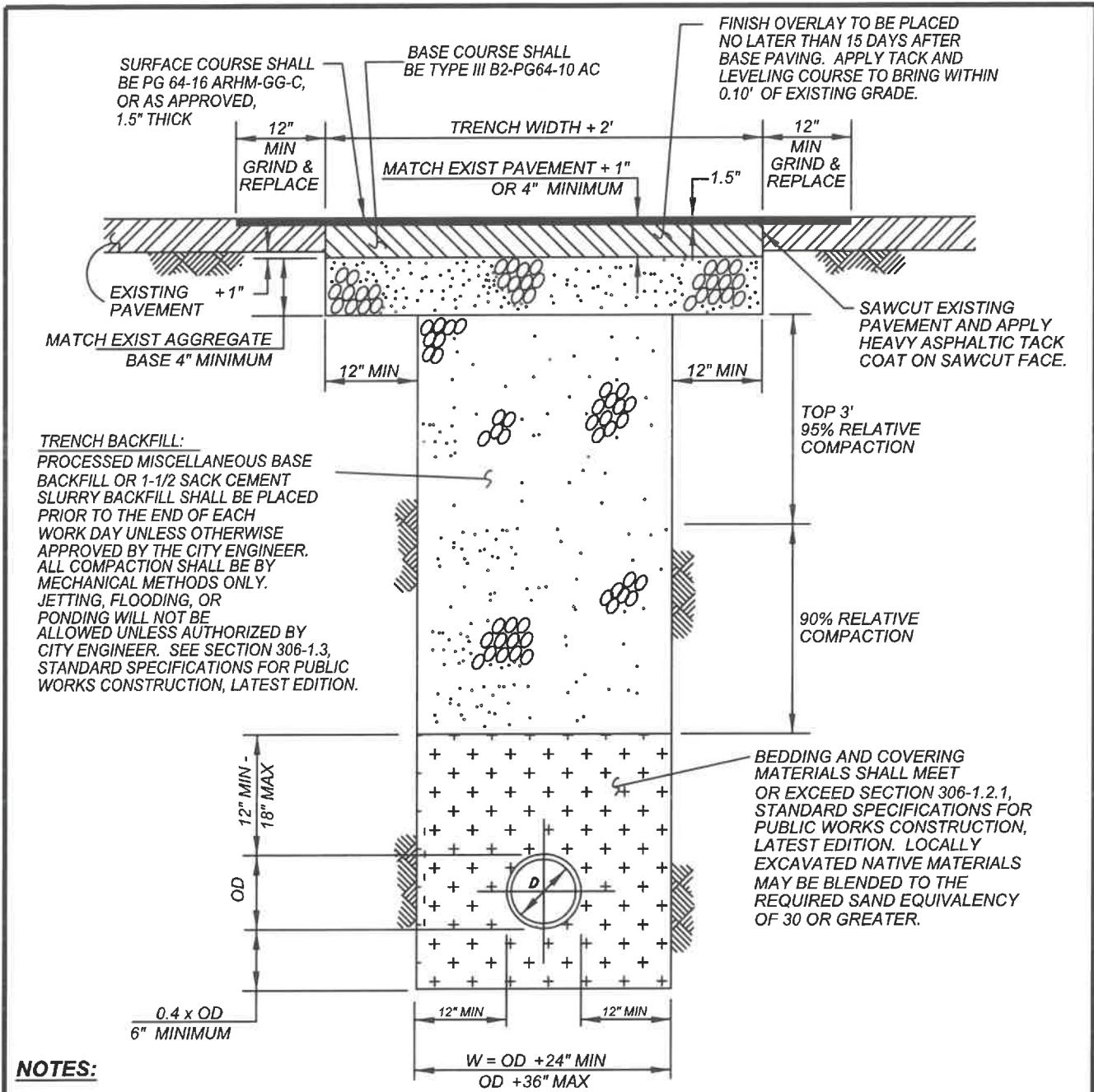
	RECOMMENDED: <div style="display: flex; justify-content: space-between; align-items: center;"> <span style="font-size: 1.2em; font-family: cursive;">MDL</span> <span>10/20/20</span> </div> <small>DIVISION MANAGER      DATE</small>	<h2 style="margin: 0;">CITY OF MORENO VALLEY</h2> <p style="margin: 0;">PUBLIC WORKS DEPARTMENT - CAPITAL PROJECTS DIVISION</p>	
	APPROVED: <div style="display: flex; justify-content: space-between; align-items: center;"> <span style="font-size: 1.2em; font-family: cursive;">M. Zwick</span> <span>10/29/2020</span> </div> <small>PUBLIC WORKS DIRECTOR / DATE CITY ENGINEER</small>	<h3 style="margin: 0;">JOIN EXISTING PAVEMENT DETAIL</h3>	



**NOTES:**

- 1.) SEE ADDITIONAL REQUIREMENTS, STD No MVSI-132C.
- 2.) ALL TRENCHES SHALL HAVE PROCESSED MISCELLANEOUS BASE BACKFILL OR 1-1/2 SACK CEMENT SLURRY BACKFILL UNLESS OTHERWISE APPROVED BY THE CITY ENGINEER.
- 3.) ALL TRENCHING AND BACKFILL SHALL BE DONE IN ACCORDANCE WITH SECTION 306, STANDARD SPECIFICATIONS FOR PUBLIC WORKS CONSTRUCTION, LATEST EDITION.
- 4.) ALL TEMPORARY PAVING SHALL HAVE A MINIMUM 2" OF AC ON LOCAL STREETS AND 3" ON ALL OTHERS, UNLESS PERMANENT PAVEMENT IS PLACED IMMEDIATELY.
- 5.) NEW FINISH ARHM OVERLAY AT ENDS OF TRENCH SHALL BE EXTENDED TO FULL WIDTH OF EXISTING BIKE LANES OR NEAREST LANE LINE AS DIRECTED BY THE CITY ENGINEER.

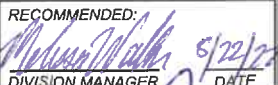
NOT TO SCALE

	RECOMMENDED:  DIVISION MANAGER      5/22/22      DATE	<h2 style="margin: 0;">CITY OF MORENO VALLEY</h2> <p style="margin: 0;">PUBLIC WORKS DEPARTMENT - CAPITAL PROJECTS DIVISION</p>
	APPROVED:  PUBLIC WORKS DIRECTOR / CITY ENGINEER      8/24/22      DATE	<h3 style="margin: 0;">PERPENDICULAR TRENCH BACKFILL AND ROADWAY REPAIR</h3>
SHEET 1 OF 7		



FINISH OVERLAY TO BE PLACED NO LATER THAN 15 DAYS AFTER BASE PAVING. APPLY TACK AND LEVELING COURSE TO BRING WITHIN 0.10' OF EXISTING GRADE.  
SURFACE COURSE PG 64-16 ARHM-GG-C, OR AS APPROVED

BASE COURSE SHALL BE TYPE III B2-PG64-10 AC

COLD MILL EXISTING PAVEMENT 1.5" DEEP FULL LANE WIDTH (TO NEAREST STRIPING)

MATCH EXIST PAVEMENT + 1" 4" MINIMUM

FOR EP CONDITION (NO C&G) SEE NOTE 4

SEE DETAIL "A"

MATCH EXIST AGGREGATE BASE 4" MINIMUM

**TRENCH BACKFILL:**

PROCESSED MISCELLANEOUS BASE BACKFILL OR 1-1/2 SACK CEMENT SLURRY BACKFILL SHALL BE PLACED PRIOR TO THE END OF EACH WORK DAY UNLESS OTHERWISE APPROVED BY THE CITY ENGINEER. ALL COMPACTION SHALL BE BY MECHANICAL METHODS ONLY. JETTING, FLOODING, OR PONDING WILL NOT BE ALLOWED UNLESS AUTHORIZED BY CITY ENGINEER. SEE SECTION 306-1.3, STANDARD SPECIFICATIONS FOR PUBLIC WORKS CONSTRUCTION, LATEST EDITION.

SAWCUT EXISTING PAVEMENT AND APPLY HEAVY ASPHALTIC TACK COAT ON SAWCUT FACE.

CURB & GUTTER (C&G)

TOP 3" 95% RELATIVE COMPACTION

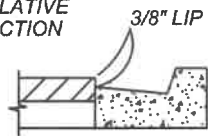

**DETAIL "A"**

90% RELATIVE COMPACTION

BEDDING MATERIAL SHALL MEET OR EXCEED SECTION 306-1.2.1, STANDARD SPECIFICATIONS FOR PUBLIC WORKS CONSTRUCTION, LATEST EDITION. LOCALLY EXCAVATED NATIVE MATERIALS MAY BE BLENDED TO THE REQUIRED SAND EQUIVALENCY OF 30 OR GREATER.

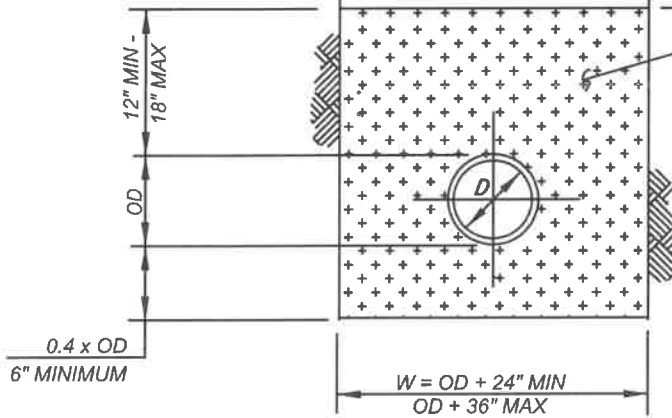

**NOTES:**

- 1.) SEE ADDITIONAL REQUIREMENTS, STD No MVS1-132C.
- 2.) ALL TRENCHING AND BACKFILL SHALL BE DONE IN ACCORDANCE WITH SECTION 306, STANDARD SPECIFICATIONS FOR PUBLIC WORKS CONSTRUCTION, LATEST EDITION.
- 3.) ALL TEMPORARY PAVING SHALL HAVE A MINIMUM 2" OF AC ON LOCAL STREETS AND 3" ON ALL OTHERS.
- 4.) FOR EDGE OF PAVEMENT (EP) CONDITION (NO CURB AND GUTTER), REMOVE AND REPLACE FULL DEPTH PAVEMENT (AB AND AC) REMNANTS UP TO 6'.

NOT TO SCALE



RECOMMENDED:  
*Nathan Walker* 8/22/22  
DIVISION MANAGER / DATE

APPROVED:  
*[Signature]* 8/22/22  
PUBLIC WORKS DIRECTOR / DATE  
CITY ENGINEER

**CITY OF MORENO VALLEY**  
PUBLIC WORKS DEPARTMENT - CAPITAL PROJECTS DIVISION

**PARALLEL TRENCH  
BACKFILL AND ROADWAY  
REPAIR**

STANDARD PLAN  
**MVSI-132B-3**

SHEET 2 OF 7



**REQUIREMENTS FOR TRENCHES OR OTHER EXCAVATIONS WITHIN PUBLIC RIGHT-OF-WAY OR EASEMENTS**

ALL WORK AND MATERIALS SHALL BE IN ACCORDANCE WITH THE "STANDARD SPECIFICATIONS FOR PUBLIC WORKS CONSTRUCTION," LATEST EDITION, UNLESS OTHERWISE SPECIFIED, INCLUDING AMENDMENTS AND SUPPLEMENTS THERETO, EXCEPTING AS HEREBY SUPPLEMENTED AND AMENDED.

**A. STANDARD REQUIREMENTS**

1. **BEDDING:** BEDDING SHALL BE DEFINED AS THAT MATERIAL SUPPORTING, SURROUNDING, AND EXTENDING TO ONE (1) FOOT ABOVE THE FACILITY. EXCEPT WHERE CONCRETE ENCASUREMENT IS USED, MATERIALS USED FOR BEDDING SHALL BE SAND, GRAVEL, CRUSHED AGGREGATE, NATIVE FREE-DRAINING, AND GRANULAR MATERIAL HAVING A SAND EQUIVALENT (SE) OF NOT LESS THAN THIRTY (30) SE.
2. **BACKFILL:** BACKFILL SHALL BE DEFINED AS THAT MATERIAL ON AND ABOVE THE BEDDING AND EXTENDING TO THE SUBGRADE FOR REPLACEMENT OF PUBLIC IMPROVEMENTS OR TO FINISH GRADE WHERE NO PUBLIC IMPROVEMENTS EXIST. MATERIALS USED FOR BACKFILL SHALL BE IN ACCORDANCE WITH THE STANDARD SPECIFICATIONS AND THIS CITY STANDARD PLAN.

**B. REPLACEMENT REQUIREMENTS**

1. **BASE:** BASE MATERIAL REPLACEMENT SHALL BE NO LESS IN THICKNESS THAN EXISTING AND IN NO CASE BE LESS THAN FOUR (4) INCHES IN THICKNESS AND SHALL BE CLASS 2 AGGREGATE BASE PER SECTION 25 OF CALTRANS STANDARD SPECIFICATIONS, LATEST EDITION. CERTIFICATION SHALL BE REQUIRED CERTIFYING THAT THE MATERIAL MEETS THE SPECIFICATIONS.
2. **PAVEMENT:** PERMANENT PAVEMENT REPLACEMENT SHALL BE NO LESS IN THICKNESS THAN THE EXISTING PLUS ONE (1) INCH, AND IN NO CASE BE LESS THAN FOUR (4) INCHES IN THICKNESS FOR BITUMINOUS ROADWAYS AND SHALL BE INSTALLED TO SAWCUT LIMITS PER CITY STANDARDS AS FOLLOWS:
  - a) PERMANENT ASPHALT PAVEMENT REPLACEMENT SHALL BE BASE COURSE TYPE III, B2 PG 64-10, SURFACE COURSE PG 64-16 ASPHALT RUBBER HOT MIX (ARHM-GG-C), OR AS APPROVED BY THE CITY ENGINEER.
  - b) WHEN TEMPORARY PAVEMENT RESURFACING IS PLACED, IT SHALL BE REMOVED AND PERMANENT PAVEMENT REPLACEMENT PLACED WITHIN A PERIOD NOT-TO-EXCEED FIFTEEN (15) WORKING DAYS FOLLOWING THE PLACEMENT OF THE TEMPORARY PAVEMENT. TEMPORARY PAVING WILL BE MAINTAINED BY THE CONTRACTOR TO PROVIDE A SAFE AND SMOOTH RIDE.
  - c) TRENCHES WITHIN TWENTY-FIVE (25) FEET OF EACH OTHER SHALL REQUIRE A ONE AND ONE-HALF (1-1/2) INCHES GRIND, AND ARHM OVERLAY FOR THE ENTIRE AREA BETWEEN TRENCHES.
3. **STRIPING:** ANY DISTURBED/DAMAGED STRIPING DUE TO TRENCHING WORK SHALL BE RESTORED AND REFRESHED TO THE CITY ENGINEER'S SATISFACTION.
4. **TESTING:** ALL TESTING SHALL BE PROVIDED BY THE CONTRACTOR. COMPACTION REPORTS SHALL BE SUBMITTED TO THE CITY ENGINEER.
5. **PROHIBITION OF PAVEMENT CUTTING:** ASPHALT CONCRETE PAVEMENT LESS THAN THREE (3) YEARS OLD SHALL NOT BE CUT EXCEPT FOR EMERGENCY REPAIRS, OR AS SPECIFICALLY APPROVED VIA WAIVER. THE FOLLOWING REPAVING REQUIREMENTS WILL BE IMPOSED:

- a) MAINTENANCE WORK THAT OCCURS ON STREETS THAT ARE FOUR (4) LANES OR GREATER [ARTERIAL STREETS]:
  1. REQUIRES A GRIND AND OVERLAY OF THE EXISTING PAVEMENT OUTSIDE OF THE T-CUT FROM LANE LINE TO LANE LINE OR FROM LANE LINE TO EDGE OF PAVEMENT/GUTTER PAN.
  2. THE LONGITUDINAL PAVEMENT RESTORATION WILL REQUIRE A 25-FOOT GRIND AND OVERLAY AS MEASURED FROM BOTH EDGES OF THE TRENCH. ANY SCARRING TO THE PAVEMENT OUTSIDE OF THE 25-FOOT LIMIT CAUSED BY THE PROJECT, ADDITIONAL GRIND AND OVERLAY WILL BE REQUIRED TO REPAIR THE SCARRING IN A CONTIGUOUS MANNER. GRIND AND OVERLAY WILL BE A MAXIMUM DEPTH OF ONE AND ONE-HALF (1-1/2) INCHES, AND MATCH EXISTING AC MATERIAL.
- b) MAINTENANCE WORK THAT OCCURS ON STREETS THAT ARE LESS THAN FOUR (4) LANES [RESIDENTIAL STREETS]:
  1. REQUIRES A GRIND AND OVERLAY OF THE EXISTING PAVEMENT OUTSIDE OF THE T-CUT FROM LANE LINE TO LANE LINE OR FROM LANE LINE TO EDGE OF PAVEMENT/GUTTER PAN.
  2. REQUIRES A GRIND AND OVERLAY OF THE EXISTING PAVEMENT OUTSIDE OF THE T-CUT FROM CENTERLINE TO EDGE OF GUTTER.
  3. THE LONGITUDINAL PAVEMENT RESTORATION WILL REQUIRE A 10-FOOT GRIND AND OVERLAY AS MEASURED FROM BOTH EDGES OF THE TRENCH. ANY SCARRING TO THE PAVEMENT OUTSIDE OF THE 10-FOOT LIMIT CALLED BY THE CONSTRUCTION, ADDITIONAL GRIND AND OVERLAY WILL BE REQUIRED TO REPAIR THE SCARRING IN A CONTIGUOUS MANNER. GRIND AND OVERLAY WILL BE A MAXIMUM DEPTH OF ONE AND ONE-HALF (1-1/2) INCHES, AND MATCH EXISTING AC MATERIAL.

6. **TIME FOR RESTORATION:** THE FINAL ASPHALT REPAIRS SHALL BE COMPLETED WITHIN FIFTEEN (15) DAYS FROM THE ORIGINAL DATE OF THE COMPLETED WORK UNLESS OTHERWISE PROVIDED EXPLICIT EXTENSION FROM THE CITY ENGINEER OR HIS/HER DESIGNEE. FOR LARGE PROJECTS, THE RESTORATION WORK SHALL BE COMPLETED PER 2,500 LINEAR FEET AND MUST BE DONE WITHIN THIRTY (30) DAYS FROM THE ORIGINAL DATE OF THE COMPLETED WORK FOR THAT SECTION OF THE PROJECT.

7. **AREA FOR RESTORATION:** PROJECT SHALL RESTORE ALL BACKFILL AND THE PAVEMENT SECTION IN AND AROUND ANY WORK AREA, INCLUDING AREAS USED BY THE CONTRACTOR FOR STAGING. IF WORK IS AT A CUL-DE-SAC, THE ENTIRE BULB WILL NEED TO BE RESTORED. IF WORK IS AT AN INTERSECTION, THE ENTIRE INTERSECTION WILL NEED TO BE RESTORED.

NOT TO SCALE

	RECOMMENDED: <i>[Signature]</i> 1/24/23 PRINCIPAL ENGINEER      DATE	<h2 style="margin: 0;">CITY OF MORENO VALLEY</h2> PUBLIC WORKS DEPARTMENT - CAPITAL PROJECTS DIVISION	
	APPROVED: <i>[Signature]</i> 1/30/23 PUBLIC WORKS DIRECTOR / DATE CITY ENGINEER	<h3 style="margin: 0;">TRENCH BACKFILL AND ROADWAY REPAIR NOTES</h3>	STANDARD PLAN <h3 style="margin: 0;">MVSI-132C-3</h3> SHEET 3 OF 7

APPLY TACK ON GRINDED PAVEMENT SURFACE. SURFACE COURSE SHALL BE PG 64-16 ARHM-GG-C, OR AS APPROVED.

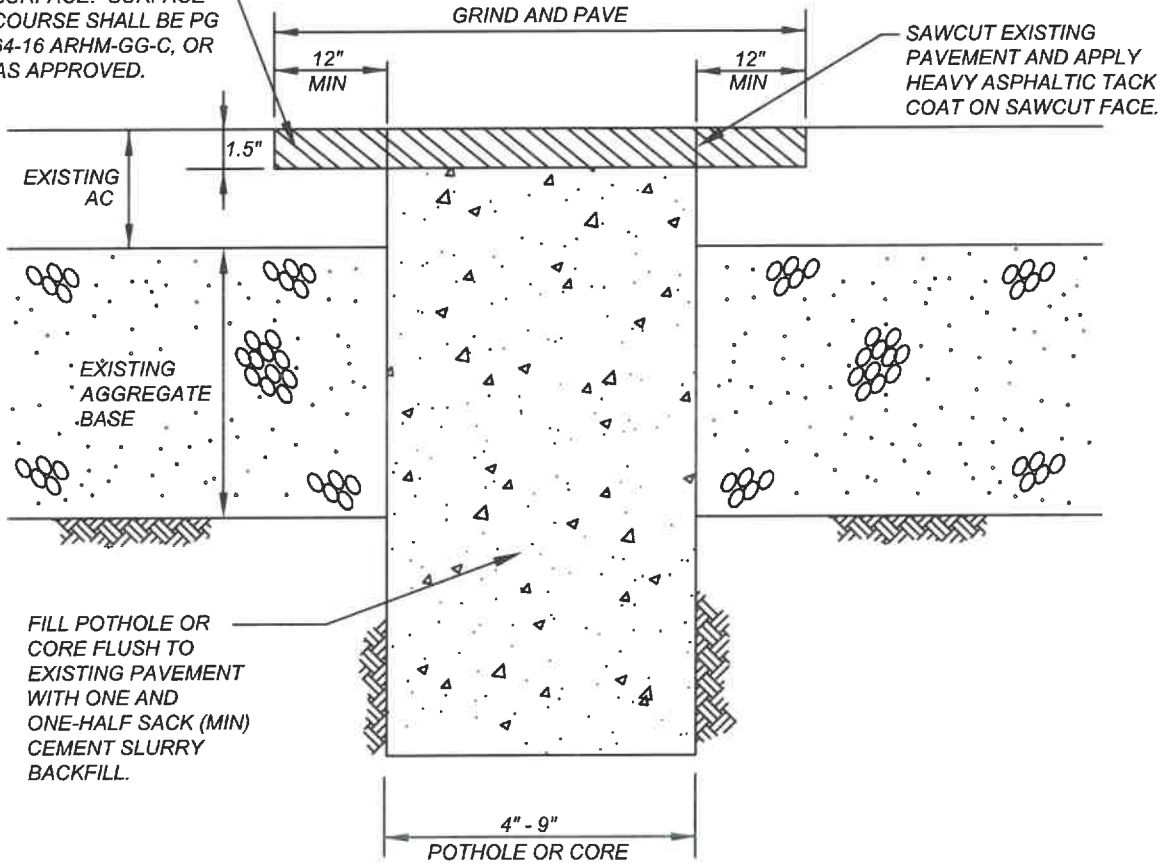

**NOTE:**

- 1.) SEE TRENCH BACKFILL AND ROADWAY REPAIR NOTES STD No MVSI-132C.
2. WHEN MULTIPLE POTHOLES SPACED 24" OR LESS ARE RUN PARALLEL TO THE TRAFFIC LANE, STANDARD PLAN MVSI-132B SHALL BE USED.

NOT TO SCALE

	RECOMMENDED: <i>Melissa Walker</i> 5/22/12 DIVISION MANAGER DATE	<h2 style="margin: 0;">CITY OF MORENO VALLEY</h2> <p style="margin: 0;">PUBLIC WORKS DEPARTMENT - CAPITAL PROJECTS DIVISION</p>	STANDARD PLAN <h3 style="margin: 0;">MVSI-132D-1</h3>
	APPROVED: <i>[Signature]</i> 3/21/12 PUBLIC WORKS DIRECTOR / DATE CITY ENGINEER	<h3 style="margin: 0;">UTILITY POTHOLE OR PAVEMENT CORE REPAIR</h3>	

FINISH OVERLAY TO BE PLACED NO LATER THAN 15 DAYS AFTER BASE PAVING. APPLY TACK AND LEVELING COURSE TO BRING WITHIN 0.10" OF EXISTING GRADE. SURFACE COURSE SHALL BE PG 64-16 ARHM-GG-C, OR AS APPROVED

BASE COURSE SHALL BE TYPE III B2-PG64-10 AC

EXISTING PAVEMENT

MATCH EXIST AGGREGATE BASE - 4" MIN IF EXIST IS 0" TO 4" (SEE NOTE 7)

**TRENCH BACKFILL:**

PROCESSED MISCELLANEOUS BASE BACKFILL OR 1-1/2 SACK CEMENT SLURRY BACKFILL SHALL BE PLACED PRIOR TO THE END OF EACH WORK DAY UNLESS OTHERWISE APPROVED BY THE CITY ENGINEER. ALL COMPACTION SHALL BE BY MECHANICAL METHODS ONLY. FLOODING OR PONDING WILL NOT BE ALLOWED UNLESS AUTHORIZED BY CITY ENGINEER. SEE SECTION 306.6.5.1, STANDARD SPECIFICATIONS FOR PUBLIC WORKS CONSTRUCTION, LATEST EDITION.

COLD MILL EXISTING PAVEMENT 1.5" DEEP

FOR PARALLEL TRENCH FULL LANE WIDTH (TO NEAREST STRIPING) (SEE NOTE 6)  
FOR PERPENDICULAR TRENCH, MIN WIDTH = 8 FEET

MATCH EXIST PAVEMENT + 1" 4" MINIMUM

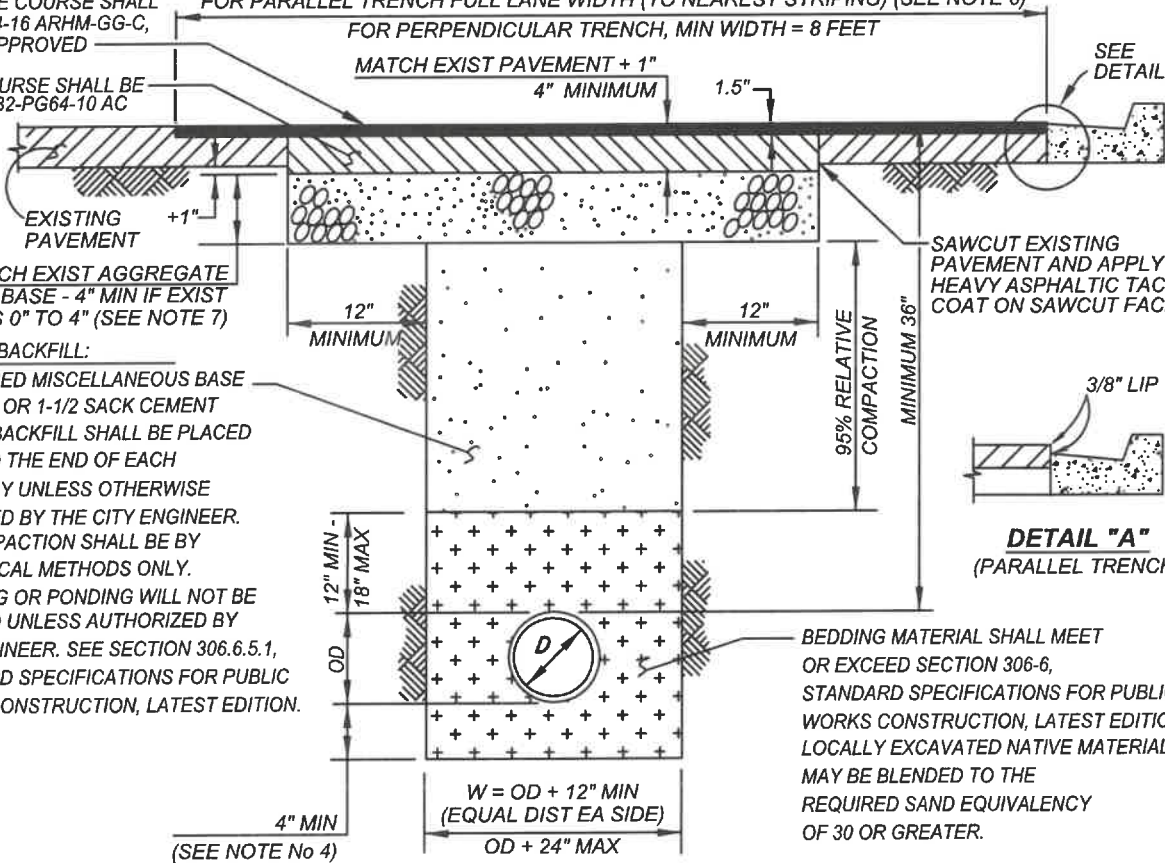

SAWCUT EXISTING PAVEMENT AND APPLY HEAVY ASPHALTIC TACK COAT ON SAWCUT FACE.

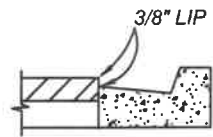

**DETAIL "A"**  
(PARALLEL TRENCH)

BEDDING MATERIAL SHALL MEET OR EXCEED SECTION 306-6, STANDARD SPECIFICATIONS FOR PUBLIC WORKS CONSTRUCTION, LATEST EDITION. LOCALLY EXCAVATED NATIVE MATERIALS MAY BE BLENDED TO THE REQUIRED SAND EQUIVALENCY OF 30 OR GREATER.

4" MIN (SEE NOTE No 4)

W = OD + 12" MIN (EQUAL DIST EA SIDE)  
OD + 24" MAX

**NOTES:**

- 1.) SEE ADDITIONAL REQUIREMENTS, STD No MVSI-132C.
- 2.) ALL TRENCHING AND BACKFILL SHALL BE DONE IN ACCORDANCE WITH SECTION 306, STANDARD SPECIFICATIONS FOR PUBLIC WORKS CONSTRUCTION, LATEST EDITION.
- 3.) ALL TEMPORARY PAVING SHALL HAVE A MINIMUM 2" OF AC ON LOCAL STREETS AND 3" ON ALL OTHERS.
- 4.) INCREASE BEDDING UNDER PIPE FROM 4" TO 6" FOR ROCK SUBGRADES.
- 5.) USE THIS STANDARD PLAN FOR UP TO AND INCLUDING 12" DIAMETER WATER LINE WITH 36" COVER OVER PIPE.
- 6.) LANE WIDTH REQUIREMENT MAY BE REDUCED AT DISCRETION OF CITY ENGINEER.
- 7.) 1-1/2 SACK CEMENT SLURRY MAY BE USED IF USED FOR TRENCH BACKFILL.

NOT TO SCALE



RECOMMENDED:  
*[Signature]* 8/22/22  
DIVISION MANAGER DATE  
APPROVED:  
*[Signature]* 8/22/22  
PUBLIC WORKS DIRECTOR / DATE  
CITY ENGINEER

**CITY OF MORENO VALLEY**

PUBLIC WORKS DEPARTMENT - CAPITAL PROJECTS DIVISION

**WATER LINE (UP TO 12" DIA)  
TRENCH BACKFILL AND  
ROADWAY REPAIR**

STANDARD PLAN  
**MVSI-132E-2**

SHEET 5 OF 7



FINISH OVERLAY TO BE PLACED NO LATER THAN 15 DAYS AFTER BASE PAVING. APPLY TACK AND LEVELING COURSE TO BRING WITHIN 0.10' OF EXISTING GRADE. SURFACE COURSE SHALL BE PG 64-16 ARHM-GG-C, OR AS APPROVED

BASE COURSE SHALL BE TYPE III B2-PG64-10 AC

COLD MILL EXISTING PAVEMENT 1.5" DEEP

FOR PARALLEL TRENCH FULL LANE WIDTH (TO NEAREST STRIPING) (SEE NOTE No 6)  
FOR PERPENDICULAR TRENCH, MIN WIDTH = 8 FEET

MATCH EXIST PAVEMENT + 1" 4" MINIMUM

SEE DETAIL "A"

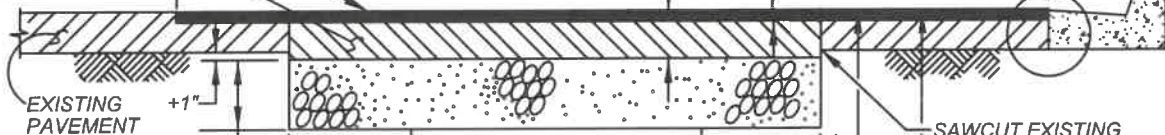

MATCH EXIST AGGREGATE BASE - 4" MIN IF EXIST IS 0" TO 4" (SEE NOTE 7)

**TRENCH BACKFILL:**

PROCESSED MISCELLANEOUS BASE BACKFILL OR 1-1/2 SACK CEMENT SLURRY BACKFILL SHALL BE PLACED PRIOR TO THE END OF EACH WORK DAY UNLESS OTHERWISE APPROVED BY THE CITY ENGINEER. ALL COMPACTION SHALL BE BY MECHANICAL METHODS ONLY. FLOODING OR PONDING WILL NOT BE ALLOWED UNLESS AUTHORIZED BY CITY ENGINEER. SEE SECTION 306.6.5.1, STANDARD SPECIFICATIONS FOR PUBLIC WORKS CONSTRUCTION, LATEST EDITION.

SAWCUT EXISTING PAVEMENT AND APPLY HEAVY ASPHALTIC TACK COAT ON SAWCUT FACE.

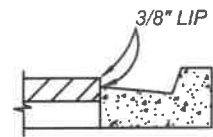



**DETAIL "A"**  
(PARALLEL TRENCH)

BEDDING MATERIAL SHALL MEET OR EXCEED SECTION 306-6, STANDARD SPECIFICATIONS FOR PUBLIC WORKS CONSTRUCTION, LATEST EDITION. LOCALLY EXCAVATED NATIVE MATERIALS MAY BE BLENDED TO THE REQUIRED SAND EQUIVALENCY OF 30 OR GREATER.

**NOTES:**

- 1.) SEE ADDITIONAL REQUIREMENTS, STD No MVS1-132C.
- 2.) ALL TRENCHING AND BACKFILL SHALL BE DONE IN ACCORDANCE WITH SECTION 306, STANDARD SPECIFICATIONS FOR PUBLIC WORKS CONSTRUCTION, LATEST EDITION.
- 3.) ALL TEMPORARY PAVING SHALL HAVE A MINIMUM 2" OF AC ON LOCAL STREETS AND 3" ON ALL OTHERS.
- 4.) INCREASE BEDDING UNDER PIPE FROM 4" TO 6" FOR ROCK SUBGRADES.
- 5.) USE THIS STANDARD PLAN FOR WATER LINE OF GREATER THAN 12" DIAMETER. MINIMUM COVER OVER PIPE IS 48".
- 6.) LANE WIDTH REQUIREMENT MAY BE REDUCED AT DISCRETION OF CITY ENGINEER.
- 7.) 1-1/2 SACK CEMENT SLURRY MAY BE USED IF USED FOR TRENCH BACKFILL.

NOT TO SCALE

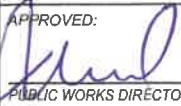
	RECOMMENDED:  DIVISION MANAGER DATE: 8/27/22	<b>CITY OF MORENO VALLEY</b> PUBLIC WORKS DEPARTMENT - CAPITAL PROJECTS DIVISION	
	APPROVED:  PUBLIC WORKS DIRECTOR / CITY ENGINEER DATE: 8/27/22	<b>WATER LINE (LARGER THAN 12" DIA) TRENCH BACKFILL AND ROADWAY REPAIR</b>	

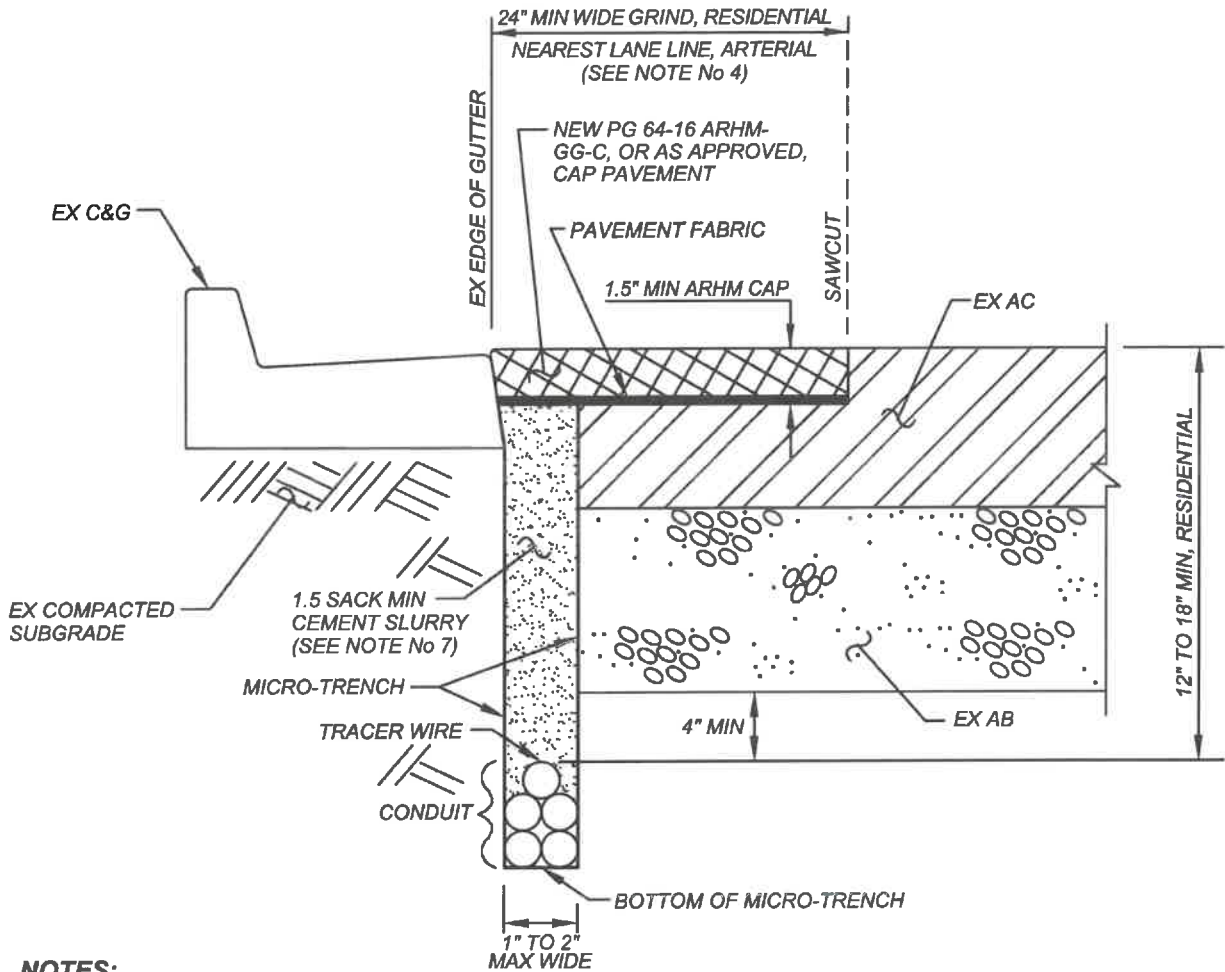

**NOTES:**

- 1.) MICRO-TRENCHING WILL NOT BE ALLOWED IN PCC OR DECORATIVE SURFACES UNLESS OTHERWISE APPROVED BY THE CITY ENGINEER.
- 2.) DETAILED PLANS SHOWING PROPOSED CONDUIT RUNS SHALL BE SUBMITTED FOR APPROVAL. CONDUIT RUNS FOR LATERALS AND STREET CROSSINGS SHALL USE SAWCUT AND OPEN TRENCH OR JACK AND BORE METHODS AS SHOWN ON THE APPROVED PLANS.
- 3.) PAVEMENT FABRIC SHALL BE IN ACCORDANCE WITH THE THE LATEST VERSION OF THE "GREENBOOK" STANDARD SPECIFICATIONS FOR PUBLIC WORKS CONSTRUCTION AND/OR THE PROJECT'S CITY-APPROVED SPECIFICATIONS OR AS RECOMMENDED BY A GEOTECHNICAL ENGINEER/REGISTERED CIVIL ENGINEER AND APPROVED BY THE CITY.
- 4.) FOR ARTERIAL STREETS, NEW ARHM PAVEMENT SHALL BE EXTENDED TO BIKE LANE STRIPING OR NEAREST LANE LINES AS REQUIRED BY THE CITY ENGINEER.
- 5.) TACK COAT SHALL BE APPLIED TO ALL EDGES PRIOR TO INSTALLING ARHM CAP.
- 6.) TOP OF CONDUITS SHALL BE 4" MIN BELOW EXISTING ROADWAY STRUCTURAL SECTION BUT NO LESS THAN 10" FROM EXISTING TOP OF PAVEMENT SURFACE, AS APPROVED BY THE CITY ENGINEER.
- 7.) CEMENT SLURRY BACKFILL SHALL BE 1.5 SACK MINIMUM AND BE IN ACCORDANCE WITH THE THE LATEST VERSION OF THE "GREENBOOK" STANDARD SPECIFICATIONS FOR PUBLIC WORKS CONSTRUCTION, SECTION 201 - CONCRETE MORTAR, AND RELATED MATERIAL.

NOT TO SCALE



RECOMMENDED  
*Melvin Walker* 8/23/22  
 DIVISION MANAGER DATE  
 APPROVED:  
*[Signature]* 8/23/22  
 PUBLIC WORKS DIRECTOR / DATE  
 CITY ENGINEER

**CITY OF MORENO VALLEY**  
 PUBLIC WORKS DEPARTMENT - CAPITAL PROJECTS DIVISION

**MICRO-TRENCHING AND JOINT  
 EXISTING PAVEMENT DETAIL**

STANDARD PLAN  
**MVSI-132G-0**

SHEET 7 OF 7



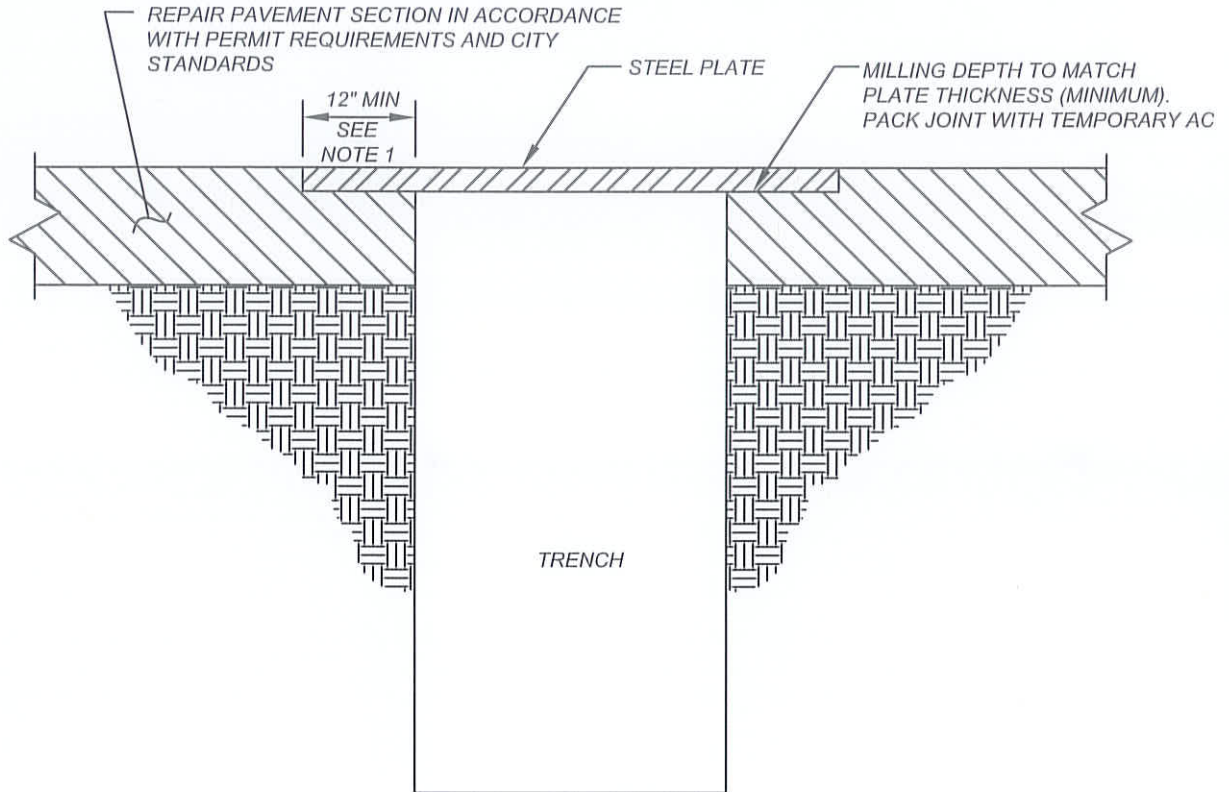



**TYPICAL TRENCH PLATE DETAIL**

**NOTES:**

- 1.) THE CONTRACTOR SHALL PROVIDE A MINIMUM 12" LAP OF STEEL PLATE ON EACH SIDE OF TRENCH TO ASSURE NO SLIPPING OF PLATE OR COLLAPSING OF TRENCH WALL. WHERE 12" LAP CANNOT BE MET, ENGINEERING DESIGN IS REQUIRED AND SHALL BE APPROVED BY THE CITY ENGINEER.
- 2.) STEEL PLATE MUST FIT SNUG WITHIN THE RECESSED AREA AND INSTALLED TO OPERATE WITH MINIMUM NOISE.
- 3.) THE PAVEMENT SHALL BE COLD PLANED TO A DEPTH EQUAL TO THE THICKNESS OF THE PLATE AND TO A WIDTH AND LENGTH EQUAL TO THE DIMENSIONS OF THE PLATE.
- 4.) THIS STANDARD SHALL BE IMPLEMENTED ON ALL PROJECTS WITHIN THE VEHICULAR TRAVELED WAY UNLESS OTHERWISE APPROVED BY THE CITY ENGINEER.
- 5.) MULTIPLE PLATES MUST BE TACK WELDED AS NEEDED TO SECURE PLATES, 6" MINIMUM.
- 6.) ALL PLATES MUST MEET REQUIRED TRAFFIC LOADS, AND BE SKID-RESISTANT. THE CONTRACTOR SHALL BE RESPONSIBLE FOR THE APPROPRIATE SELECTION AND MAINTENANCE OF THE STEEL PLATES.
- 7.) STEEL PLATES MUST BE REMOVED AND PERMANENT PAVEMENT SHALL BE PLACED WITHIN FIFTEEN (15) WORKING DAYS OR AS APPROVED BY THE CITY ENGINEER.
- 8.) ADVANCE WARNING SIGNS "STEEL PLATES AHEAD" SHALL BE PLACED WHEN PLATING IS WITHIN THE TRAVELED WAY.

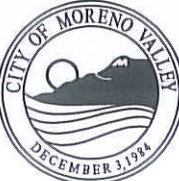
NOT TO SCALE

	RECOMMENDED:  / 1/21/14 DIVISION MANAGER / DATE	<b>CITY OF MORENO VALLEY</b> PUBLIC WORKS DEPARTMENT - CAPITAL PROJECTS DIVISION	STANDARD PLAN
	APPROVED:  / 1/29/14 PUBLIC WORKS DIRECTOR / DATE CITY ENGINEER	<b>RECESSED TRENCH PLATE DETAIL</b>	<b>MVSI-133-0</b>

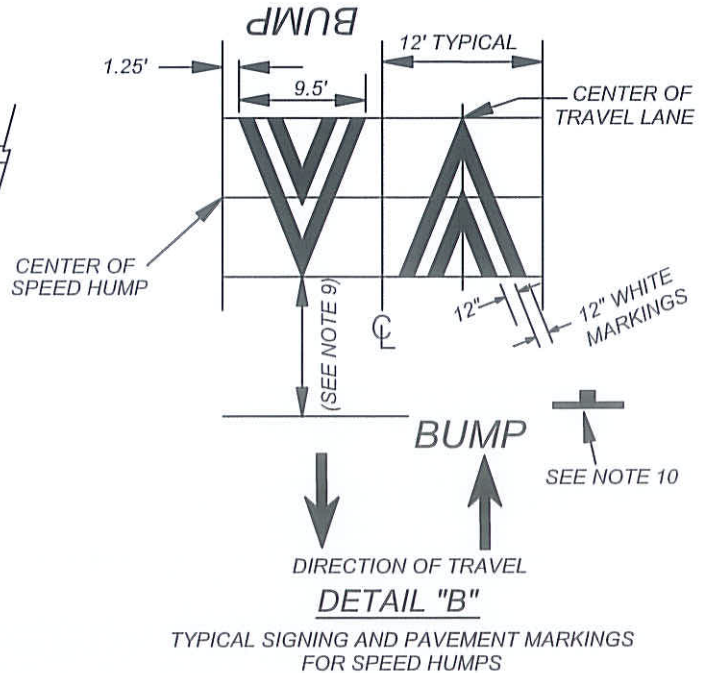
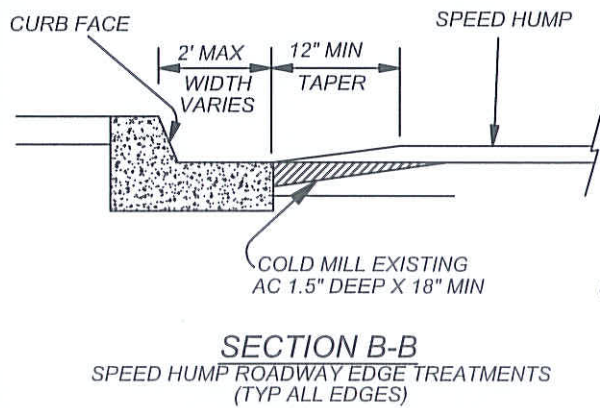
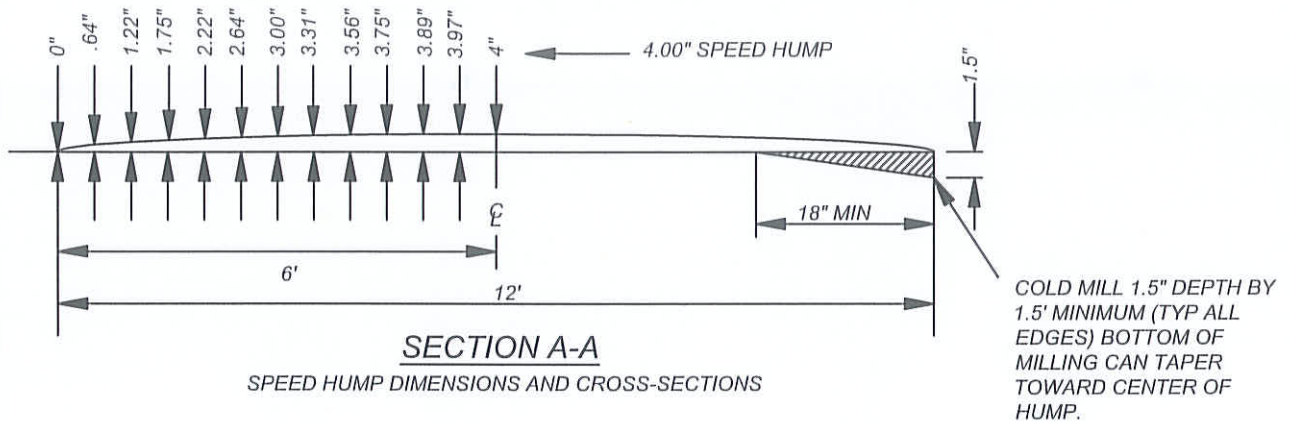
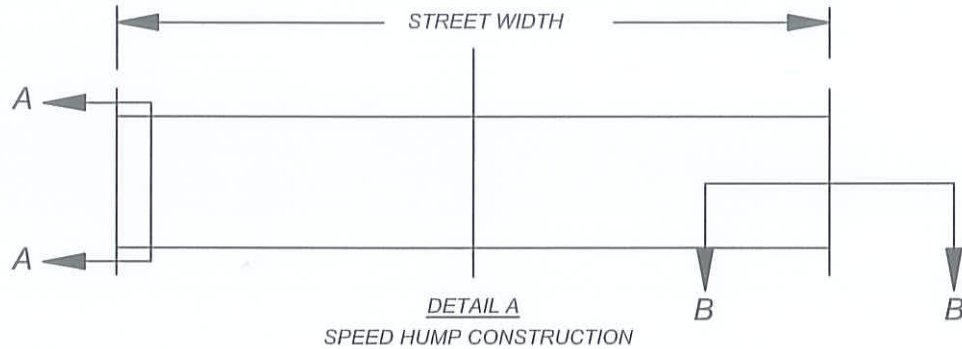

NOT TO SCALE

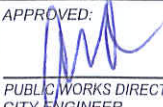
	RECOMMENDED: <i>EL</i> DIVISION MANAGER DATE: 1/22/14	<b>CITY OF MORENO VALLEY</b> PUBLIC WORKS DEPARTMENT - TRANSPORTATION ENGINEERING DIVISION  <b>SPEED HUMP DETAIL AND PLACEMENT</b>	STANDARD PLAN <b>MVSI-134A-0</b>
	APPROVED:  PUBLIC WORKS DIRECTOR / CITY ENGINEER DATE: 1/29/14		SHEET 1 OF 2

**NOTES:**

- 1.) CLEAN AND PLACE SS-1H BINDER MATERIAL PRIOR TO PLACEMENT OF ASPHALT MATERIAL. - SECTION 302-5.4
- 2.) INSTALLATION OF SPEED HUMPS SHALL BE COMPLETED IN TWO LIFTS.
  - 1ST LIFT: FURNISH AND PLACE TYPE III B2-PG64-10 ASPHALT MATERIAL.
  - 2ND LIFT: FURNISH AND PLACE TYPE III C3-PG64-10 ASPHALT MATERIAL.
- 3.) STRIPE 12" WIDE CHEVRONS ON ASPHALT PAVING PER DETAIL "B".
- 4.) STENCIL "BUMP" LEGEND IN 8' LETTERS. OBTAIN APPROVAL OF STENCIL PRIOR TO INSTALLATION.
- 5.) ALL STRIPING MUST BE INSTALLED PER THE LATEST CALTRANS STANDARD PLANS A10A THROUGH A24E, THE LATEST CALIFORNIA MANUAL ON UNIFORM TRAFFIC CONTROL DEVICES (CA MUTCD) AND CITY OF MORENO VALLEY STANDARD PLANS, SECTION 4.
- 6.) ALL STENCILS USED FOR INSTALLING PAVEMENT MARKINGS MUST CONFORM TO THE LATEST CALTRANS STENCILINGS STANDARD A24A THROUGH A24E.
- 7.) ALL STRIPING MUST BE INSTALLED USING THERMOPLASTIC (UNLESS OTHERWISE SPECIFIED) PER THE LATEST CALTRANS STANDARD SPECIFICATIONS. ALL PAVEMENT MARKINGS (LEGENDS) MUST BE THERMOPLASTIC.
- 8.) THE PLACEMENT OF SPEED HUMPS SHALL BE DETERMINED BY THE CITY TRAFFIC ENGINEER.
- 9.) THE PLACEMENT OF PAVEMENT MARKINGS ("BUMP" LEGEND) SHALL BE INSTALLED DIRECTLY ADJACENT TO THE SPEED BUMP SIGN LOCATIONS CENTERED ON THE VEHICLE'S DIRECTION OF TRAVEL OR AS DETERMINED BY THE CITY TRAFFIC ENGINEER.
- 10.) NEW W13-1 (15) & W8-1 ("BUMP") ON NEW POST SHALL BE INSTALLED PER CITY STDS MVLT-414A-0 AND MVLT-414B-0. LOCATION OF THE SIGN WILL BE DETERMINED BY THE CITY TRAFFIC ENGINEER.

NOT TO SCALE

	RECOMMENDED: <u>EL</u> <u>1/22/14</u> DIVISION MANAGER DATE	<b>CITY OF MORENO VALLEY</b> PUBLIC WORKS DEPARTMENT - TRANSPORTATION ENGINEERING DIVISION	
	APPROVED: <u>[Signature]</u> <u>1/29/14</u> PUBLIC WORKS DIRECTOR / DATE CITY ENGINEER	<b>SPEED HUMP INSTALLATION NOTES</b>	STANDARD PLAN <b>MVSI-134B-0</b> SHEET 2 OF 2



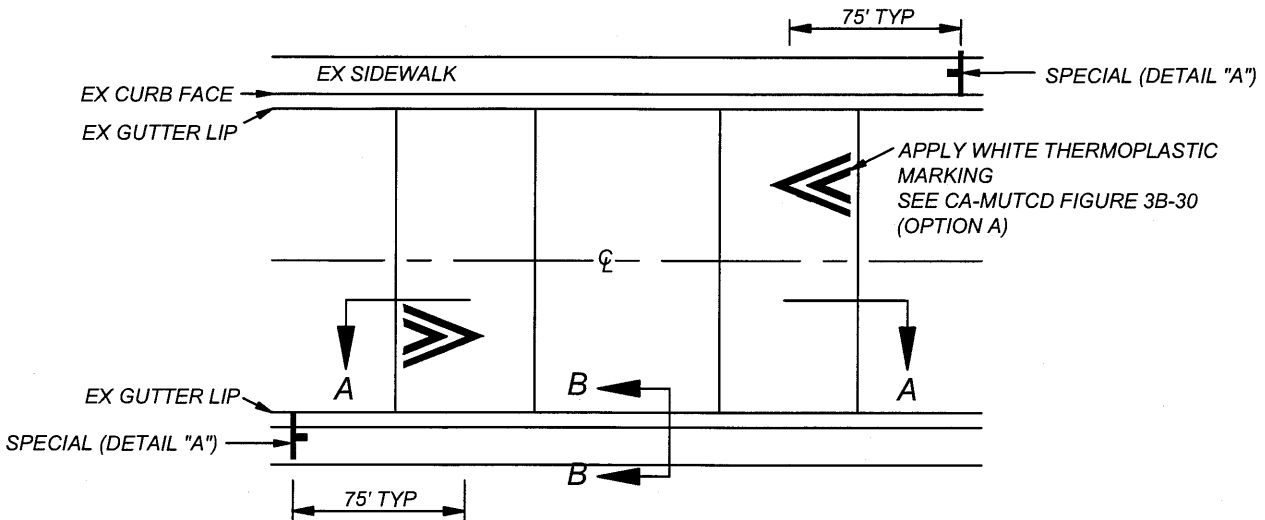

SPECIAL (DETAIL "A") SIGN  
6" SERIES/E LETTERS

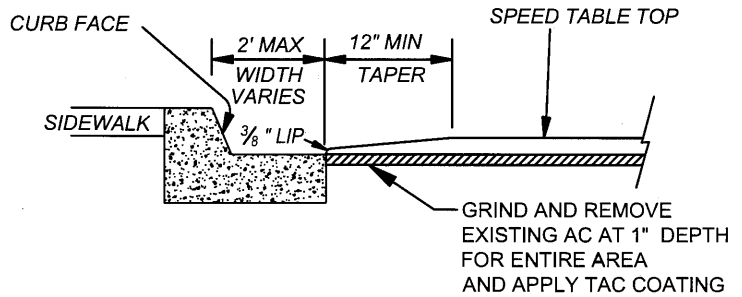

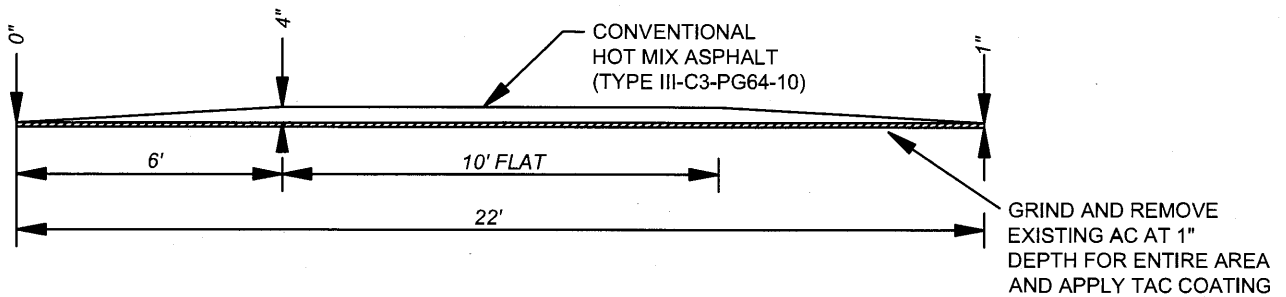

**SECTION B-B**  
SPEED TABLE ROADWAY EDGE TREATMENTS  
(TYP ALL EDGES)



**SECTION A-A**

NOT TO SCALE

	RECOMMENDED: <b>EL</b> 12/22/16 DIVISION MANAGER      DATE	<b>CITY OF MORENO VALLEY</b> PUBLIC WORKS DEPARTMENT - TRANSPORTATION ENGINEERING DIVISION	STANDARD PLAN
	APPROVED:  PUBLIC WORKS DIRECTOR / DATE CITY ENGINEER      1/20/17		<b>SPEED TABLE</b>
			SHEET 1 OF 1

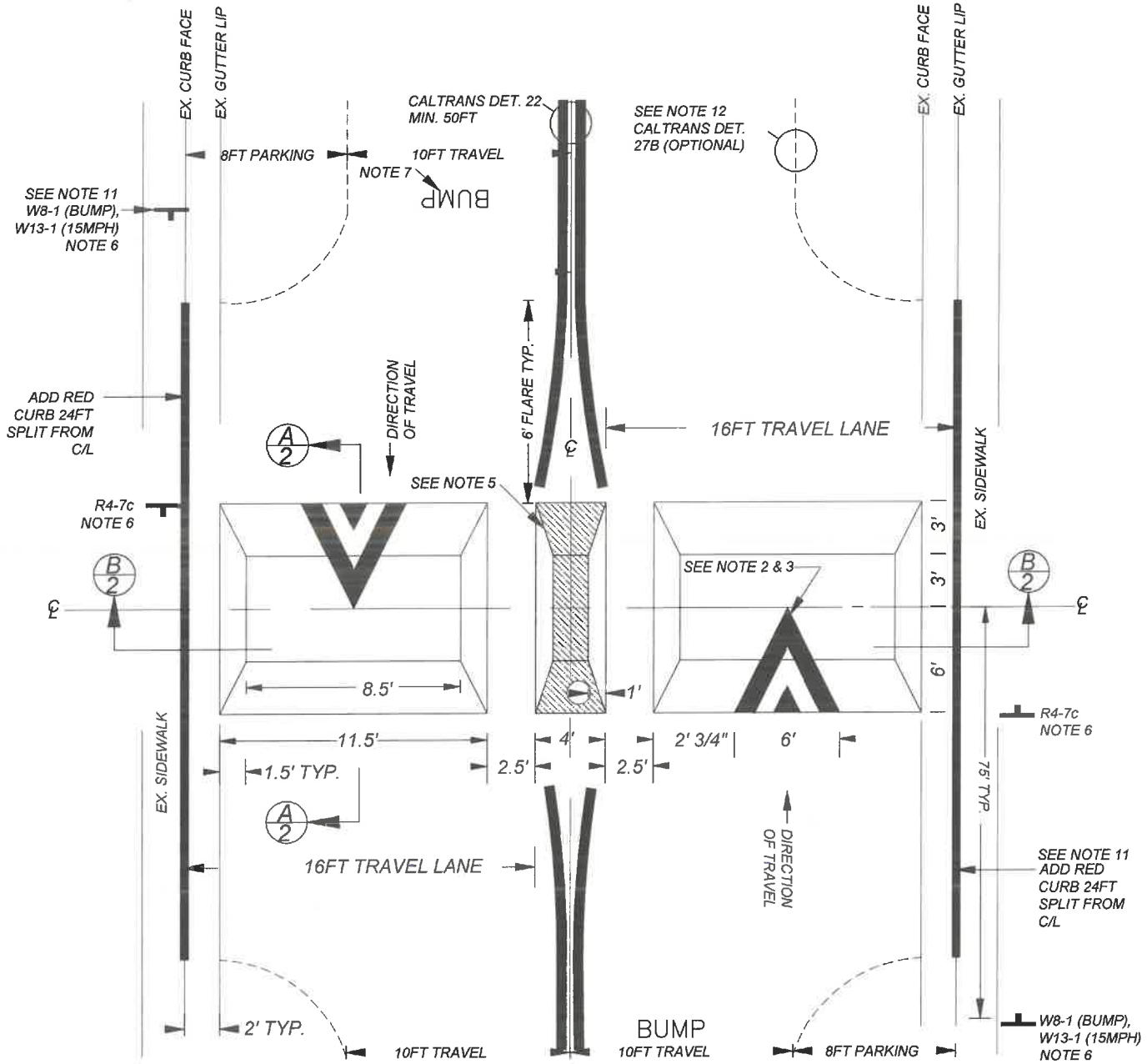

**PLAN VIEW**

**SIGN CHART**

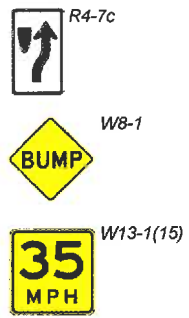

**LEGEND**

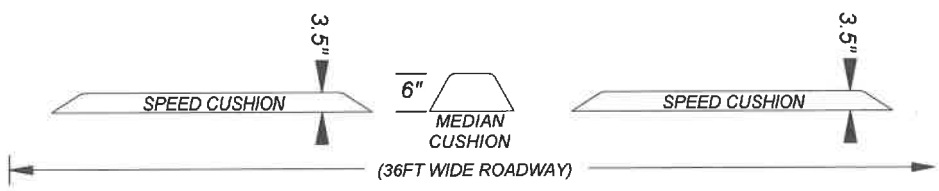
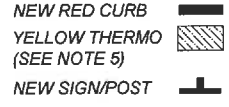

**CROSSECTION PROFILE VIEW**

NOTES / SECTIONS: SEE MVSI-136D-0

RECOMMENDED:  
*WLSm* 2/1/2024  
 DIVISION MANAGER DATE  
 APPROVED:  
*Melvin* 2/1/24  
 PUBLIC WORKS DIRECTOR/ DATE  
 CITY ENGINEER

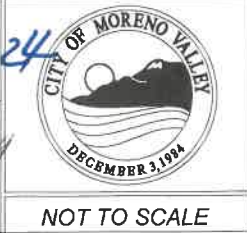

**CITY OF MORENO VALLEY**  
 PUBLIC WORKS DEPARTMENT - TRANSPORTATION ENGINEERING DIVISION

**SPEED CUSHION DETAIL  
 36FT WIDE ROADWAY  
 PLACEMENT**

STANDARD PLAN  
**MVSI-136A-0**  
 SHEET 1 OF 4



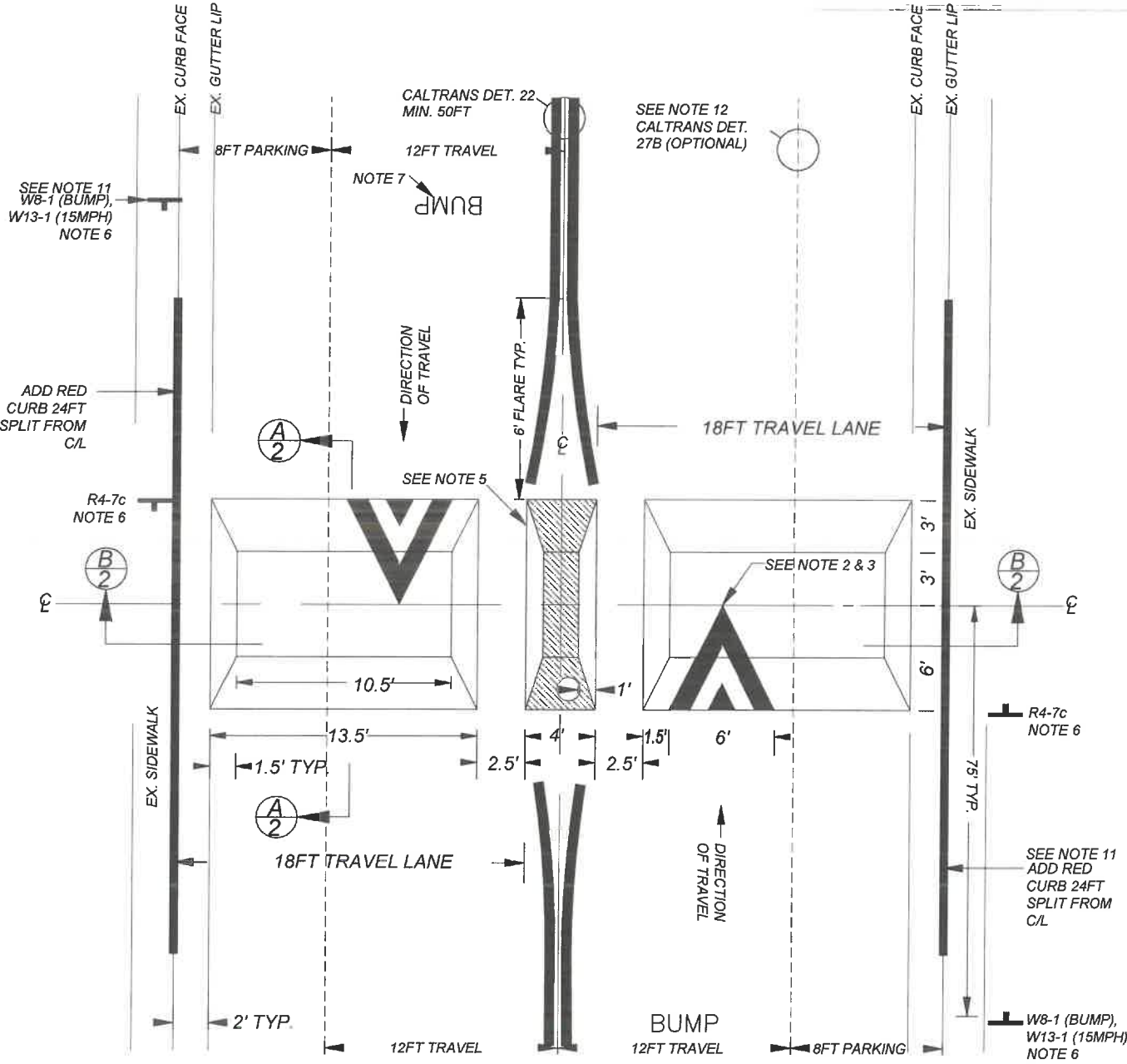

**PLAN VIEW**

**SIGN CHART**

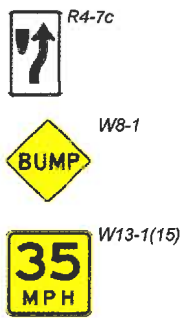

**LEGEND**

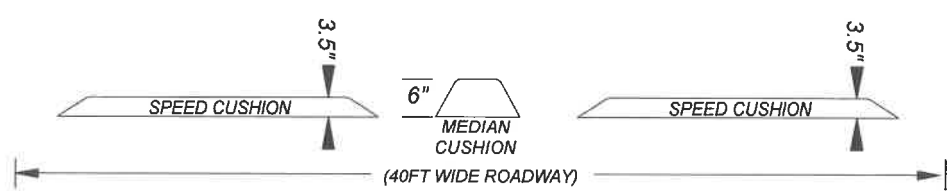
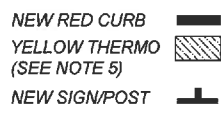

**CROSSSECTION PROFILE VIEW**

NOTES / SECTIONS: SEE MVS1-136D-0

RECOMMENDED:  
*Weisman* 2/1/2024  
 DIVISION MANAGER DATE  
 APPROVED:  
*Michael J. Williams* 2/1/24  
 PUBLIC WORKS DIRECTOR/ DATE  
 CITY ENGINEER



**CITY OF MORENO VALLEY**  
 PUBLIC WORKS DEPARTMENT - TRANSPORTATION ENGINEERING DIVISION  
**SPEED CUSHION DETAIL**  
**40FT WIDE ROADWAY**  
**PLACEMENT**  
 STANDARD PLAN  
**MVSI-136B-0**  
 SHEET 2 OF 4



**NOTES:**

1. ALL SIGNING AND STRIPING SHALL MEET THE LATEST CALTRANS STANDARDS AND CAMUTCD LATEST VERSION.
2. CITY ENGINEER DECISION FOR PLACEMENT AND NUMBER OF CHEVRON ARROWS.
3. APPLY WHITE THERMOPLASTIC (EXTRA BEADS) MARKING, SEE CAMUTCD FIGURE 3B-29(OPTION A).
4. ALL EDGES ARE TO PARABOLIC.
5. APPLY YELLOW THERMOPLASTIC (XTRA BEADS) ON MEDIAN CUSHION, AS SHOWN WITH HATCH.
6. INSTALL SIGN PER CITY STDS. MVL-412-0 TO MVL-414B-1.
7. INSTALL THERMOPLASTIC WHITE PAVEMENT LEGEND 8' LETTERING BY 7'4" WIDE (CALTRANS METRIC STENCILING). PAVEMENT MARKING "BUMP" LEGEND SHALL BE INSTALLED DIRECTLY ADJACENT TO THE BUMP W8-1/W13-1 SIGNS AND CENTERED ON THE VEHICLE'S DIRECTION OF TRAVEL.
8. CLEAN AND PLACE SS-1H BINDER MATERIAL PRIOR TO PLACEMENT OF ASPHALT MATERIAL. - SECTION 302-5.4
9. INSTALLATION OF SPEED CUSHIONS SHALL BE COMPLETED IN TWO LIFTS.
  - 1ST LIFT: FURNISH AND PLACE TYPE III B2-PG64-10 ASPHALT MATERIAL.
  - 2ND LIFT: FURNISH AND PLACE TYPE III C3-PG64-10 ASPHALT MATERIAL.
10. THE PLACEMENT OF SPEED CUSHIONS SHALL BE DETERMINED BY THE CITY TRAFFIC ENGINEER.
11. RED CURB SHOWN GIVES MINIMUM LENGTH, CITY ENGINEER WILL ADJUST THE NEED FOR RED CURB BASE ON ROAD CHARACTERISTICS AND CONFLICTS.
12. PARKING STRIPE CALTRANS DETAIL 27B NEED WILL BE DETERMINED BY CITY ENGINEER.

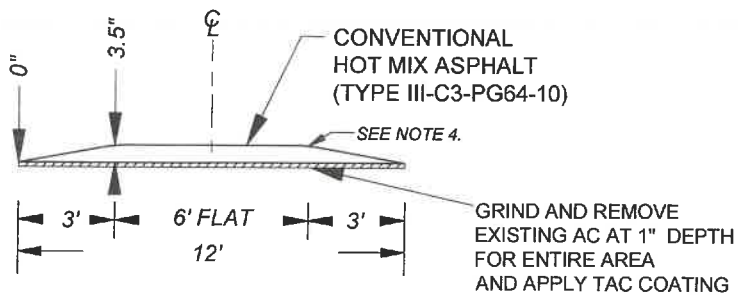

**SECTION A-A**

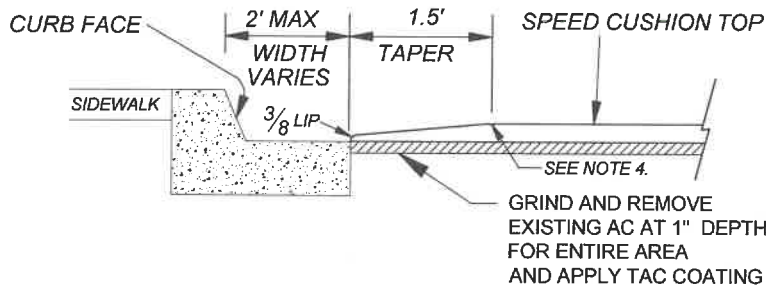

**SECTION B-B**

**SPEED CUSHION ROADWAY EDGE TREATMENT**

**\*SPEED CUSHION ARE TO BE INSTALLED AS AN ALTERNATIVE TO CITY STANDARD SPEED HUMPS WHEN CITY FIRE DEPARTMENT DEEMS NECESSARY**

RECOMMENDED:  
  
 DIVISION MANAGER  
 DATE 9/3/2024

APPROVED:  
  
 PUBLIC WORKS DIRECTOR / CITY ENGINEER  
 DATE 9/11/24



NOT TO SCALE

**CITY OF MORENO VALLEY**

PUBLIC WORKS DEPARTMENT - TRANSPORTATION ENGINEERING DIVISION

**SPEED CUSHION\***  
**36FT/40FT/44FT WIDE ROADWAY**  
**NOTES**

STANDARD PLAN  
**MVSI-136D-0**

SHEET 4 OF 4

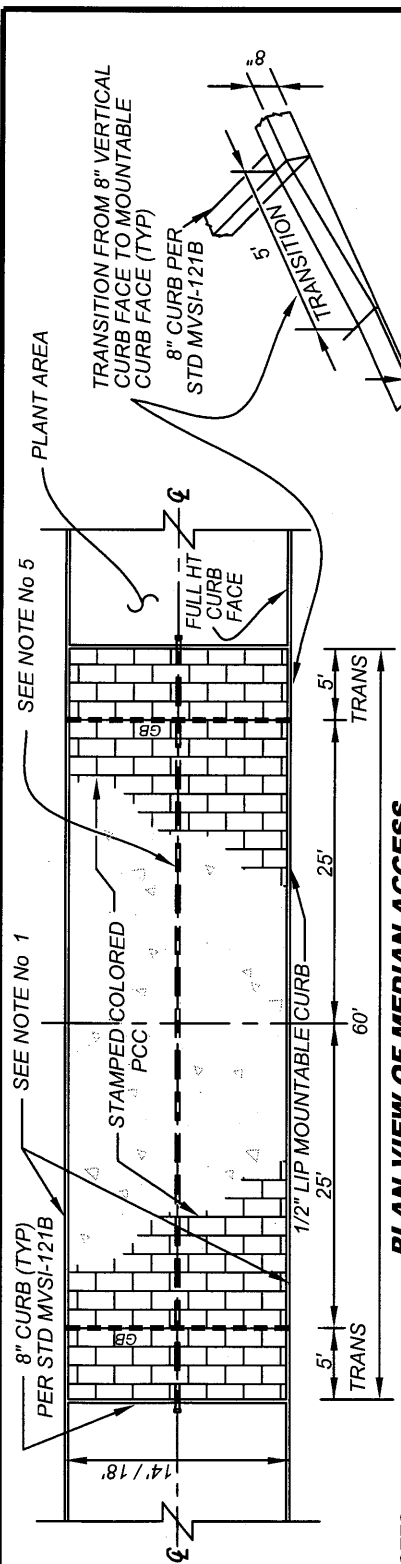

**TRANSITION DETAIL**

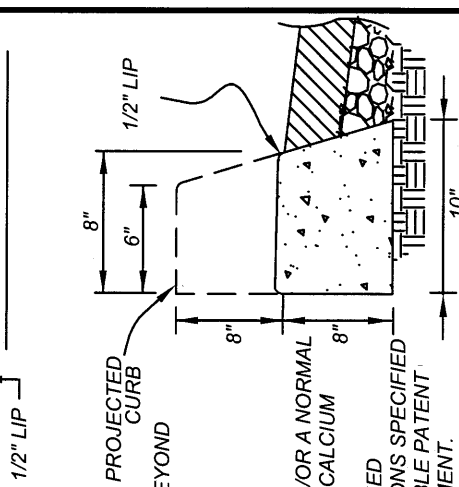

**MOUNTABLE CURB DETAIL**

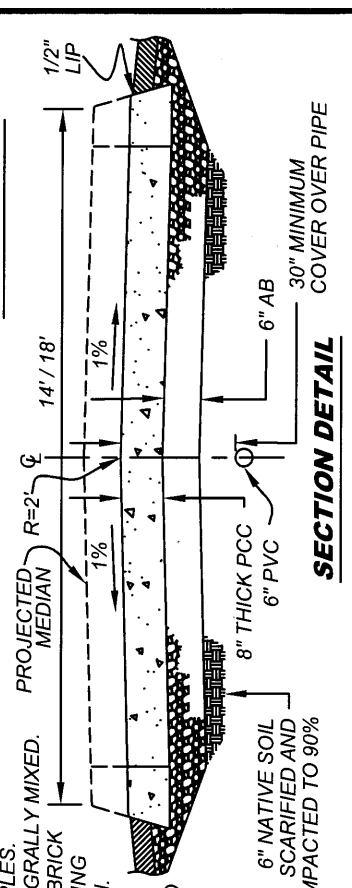

**PLAN VIEW OF MEDIAN ACCESS**

NOTES:

- 1.) LOCATION OF THE MEDIAN ACCESS SHOULD BE AS APPROVED BY THE TRANSPORTATION DIVISION AND IN CONSULTATION WITH THE FIRE DEPARTMENT.
- 2.) SEE STD MVSI-121B-0 FOR TYPE "8A" CURB.
- 3.) ALL LANDSCAPE, IRRIGATION, AND DRAINAGE PLANS AND DEVICES SHALL BE APPROVED BY THE CITY PRIOR TO INSTALLATION.
- 4.) THE LANDSCAPE PLAN SHALL MINIMIZE RUNOFF TO THE PAVEMENT.
- 5.) A 6" PVC CL 315 PIPE SHALL BE INSTALLED ALONG THE CENTERLINE OF THE MEDIAN, EXTENDING 6" BEYOND THE CURB/HARDSCAPE ON BOTH SIDES, AND CAPPED AT BOTH ENDS.
- 6.) SEE STD MVLI-561A-0 OR MVLI-561B-0 FOR SLEEVING DETAIL.
- 7.) MODIFICATIONS TO THIS STANDARD MAY BE MADE BY THE CITY ENGINEER.
- 8.) CONSTRUCT TRANSVERSE AND LONGITUDINAL WEAKENED - PLANE JOINTS IN CONCRETE PAD AT APPROXIMATELY 10' INTERVALS.
- 9.) CONCRETE SHALL BE CLASS 560-C-3250. AN AIR-ENTRAINING AGENT CONFORMING TO ASTM C260 AND/OR A NORMAL SET OR RETARDED SET WATER REDUCING ADMIXTURE CONFORMING WITH ASTM C494 MAY BE USED. CALCIUM CHLORIDE WILL NOT BE ALLOWED. THE SLUMP SHALL NOT EXCEED 4".
- 10.) THE CONTRACTOR FOR THE STAMPED CONCRETE SHALL PROVIDE EVIDENCE THAT THEY ARE QUALIFIED TO AND HAS PREVIOUSLY PRODUCED SUCH TEXTURED PAVING AND CAN COMPLY WITH THE PROVISIONS SPECIFIED HEREIN. THE CONTRACTOR SHALL ALSO STIPULATE THAT THEY WILL NOT INFRINGE ON ANY APPLICABLE PATENT RIGHTS AND WILL HOLD THE CITY HARMLESS FROM ANY DAMAGES ARISING FROM PATENT INFRINGEMENT.
- 11.) THE CONTRACTOR SHALL SUBMIT A SAMPLE OF THE SPECIFIED STAMPED CONCRETE A MINIMUM OF 4 S.F. BY 4 INCHES OR SHALL INDICATE TWO LOCATIONS WITHIN A 10 MILE LIMIT FROM THE CITY, WHERE THEIR PRIOR WORK OF SIMILAR STAMPED CONCRETE CAN BE OBSERVED. THE SAMPLES SHALL MEET THE APPROVAL OF THE CITY ENGINEER AND ALL WORK SHALL MATCH THE APPROVED SAMPLES.
- 12.) COLORING MIXTURE FOR STAMPED CONCRETE SHALL BE INTEGRALLY MIXED.
- 13.) THE COLORING MIXTURE FOR STAMPED CONCRETE SHALL BE "BRICK RED" No 160, BY DAVIS COLORS, OR APPROVED EQUAL, MATCHING CITY ENGINEER'S SELECTED AND APPROVED SAMPLE PATTERN. A TRANSLUCENT CURING COMPOUND SHALL BE APPLIED UNIFORMLY TO CONCRETE IMMEDIATELY AFTER FINISHING.
- 14.) THE CONTRACTOR SHALL DELIVER TO THE CITY ENGINEER TWO LABELS FROM THE PACKAGES CONTAINING THE SELECTED COLORING AGENT USED IN THE COURSE OF THE SPECIFIED WORK.

NOT TO SCALE

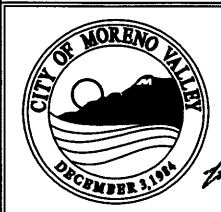

RECOMMENDED:  
*[Signature]* 1-6-17  
 DIVISION MANAGER DATE

APPROVED:  
*[Signature]* 1/20/17  
 PUBLIC WORKS DIRECTOR / DATE  
 CITY ENGINEER

**CITY OF MORENO VALLEY**  
 PUBLIC WORKS DEPARTMENT - CAPITAL PROJECTS DIVISION

**EMERGENCY VEHICLE  
 MEDIAN ACCESS**

STANDARD PLAN  
**MVSI-140-0**  
 SHEET 1 OF 1

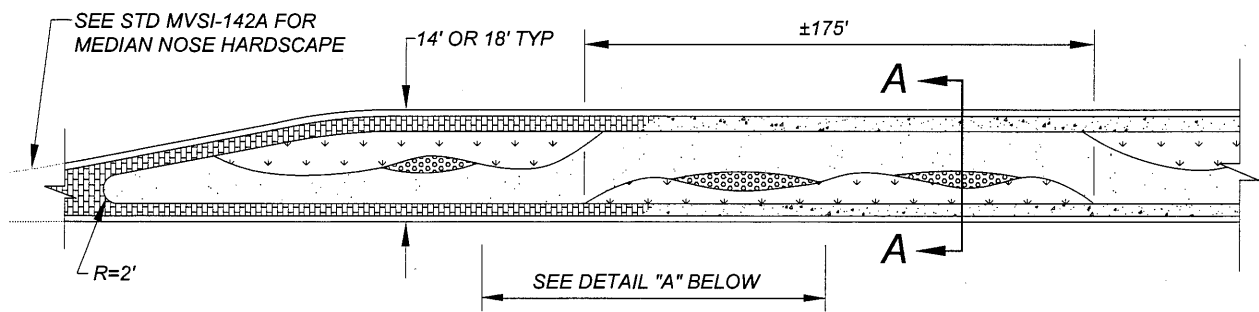

**TYPICAL LAYOUT / MEDIAN LANDSCAPE DESIGN**

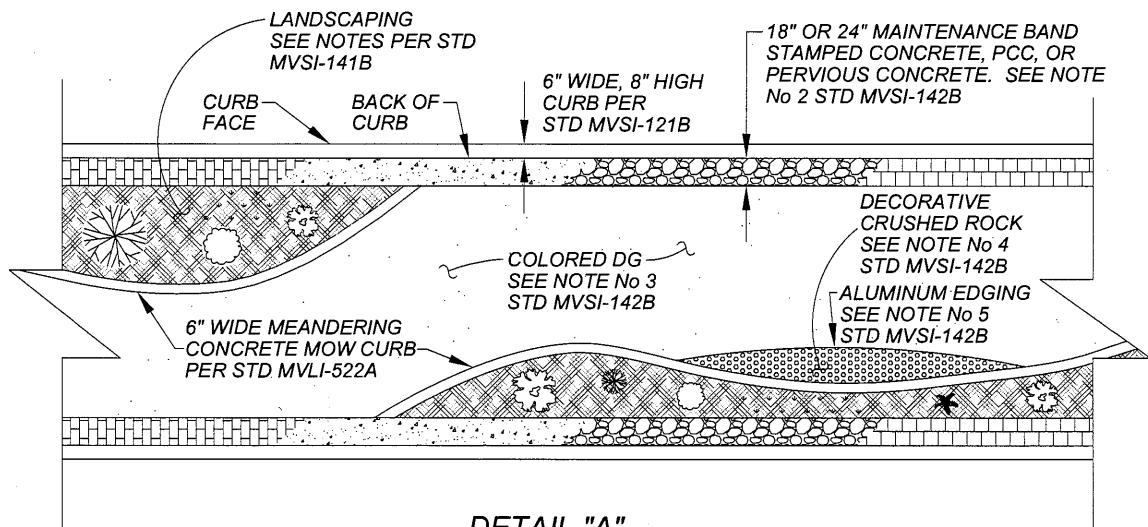

**DETAIL "A"**

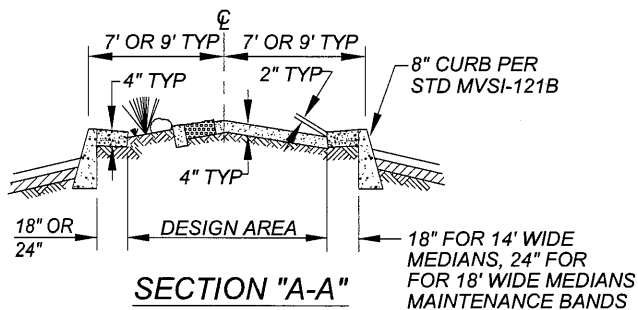

**SECTION "A-A"**

NOTE: SEE MVS-141B-0 FOR MEDIAN LANDSCAPE NOTES

NOT TO SCALE

	RECOMMENDED:  DIVISION MANAGER DATE: 1-6-17	<b>CITY OF MORENO VALLEY</b> PUBLIC WORKS DEPARTMENT - CAPITAL PROJECTS DIVISION	
	APPROVED:  PUBLIC WORKS DIRECTOR / DATE CITY ENGINEER	<b>MEDIAN LANDSCAPE MEANDERING DESIGN</b>	



**NOTES:**

- 1.) MAINTENANCE BAND, DECORATIVE CRUSHED ROCK, ALUMINUM EDGING, DECOMPOSED GRANITE, PER STD MVSI-142A-1 AND MVSI-142B-1.
- 2.) ALL PLANTS SHALL HAVE WATER CONSERVATION ATTRIBUTES AND SHALL BE CLIMATE-APPROPRIATE FOR MORENO VALLEY. IN GENERAL, PLANTS MAY BE SELECTED FROM THE INLAND EMPIRE GARDEN FRIENDLY PLANT GUIDE (WWW.IEGARDEN FRIENDLY.COM), AND AS APPROVED BY THE CITY ENGINEER.
- 3.) IRRIGATION SHALL BE PER THE WATER CONSERVATION IN LANDSCAPING ACT OF 2006 (ASSEMBLY BILL No 1881) - CALIFORNIA'S MODEL WATER EFFICIENT LANDSCAPE ORDINANCE. PER THE ORDINANCE, WATER CONSERVATION SHALL INCLUDE WATER EFFICIENT LANDSCAPE DESIGN, INSTALLATION, AND MAINTENANCE INCLUDING, BUT NOT LIMITED TO, PLANT SELECTION AND GROUPINGS OF PLANTS BASED ON WATER NEEDS AND CLIMATIC, GEOGRAPHICAL, OR TOPOGRAPHICAL CONDITIONS; EFFICIENT IRRIGATION SYSTEMS; PRACTICES THAT FOSTER LONG TERM WATER CONSERVATION; AND ROUTINE REPAIR AND MAINTENANCE OF IRRIGATION SYSTEMS.
- 4.) FOR STANDARD MEDIAN SECTION: DRAINAGE RUNOFF SHALL FLOW LONGITUDINALLY ALONG BACK OF MOW STRIP TO APPROVED DRAINAGE COLLECTION DEVICE, AS NECESSARY.
- 5.) PLACEMENT OF PLANTS SHALL NOT OBSTRUCT THE FLOW OF WATER TO THE EXTENT THAT IT WILL OVER FLOW CURBS.
- 6.) ALL LANDSCAPE, IRRIGATION, AND DRAINAGE PLANS AND DEVICES SHALL BE APPROVED BY THE CITY PRIOR TO INSTALLATION.
- 7.) THE LANDSCAPE AND IRRIGATION PLANS SHALL MINIMIZE RUNOFF TO THE PAVEMENT, MINIMIZE MAINTENANCE, PROMOTE WATER CONSERVATION AND ASSURE DESIGN CONTINUITY OF THE PROPOSED PROJECT WITH EXISTING MEDIANS ON THE STREET. THE LANDSCAPE PLAN SO PREPARED SHALL CONSIST OF AREAS OF CREATIVE HARDSCAPE AND PLANTING, WITH NO MORE THAN 25% HARDSCAPE. THE LANDSCAPE PLAN SHALL BE SUBJECT TO FINAL APPROVAL BY THE CITY ENGINEER.
- 8.) LANDSCAPING DESIGN SHALL BE PER THE CITY'S PUBLIC WORKS LANDSCAPE DESIGN GUIDELINES AND THE CITY'S STANDARD PLANS, AS FOUND ON THE CITY'S WEBSITE. BELOW ARE EXAMPLES OF APPROVED SHRUBS/PLANTS AND TREES.

**EXAMPLES OF APPROVED SHRUBS/PLANTS :**

COMMON NAME:

MEDICINAL ALOE  
 DEER GRASS  
 DESERT SPOON  
 LANTANA  
 MEXICAN GRASS TREE  
 RED YUCCA  
 SILVERY CASSIA  
 SOCIETY GARLIC  
 TEXAS LAUREL  
 TEXAS SAGE  
 VISTA JOJOBA

SCIENTIFIC NAME:

ALOE VERA  
 MUHLENBERGIA  
 DASYLIRION WHEELERI  
 LANTANA  
 DASYLIRION LONGISIMUM  
 HESPERALOE PARVIFLORA  
 CASSIA PHYLLODINEA  
 TULBAGHIA VIOLACEA  
 SOPHORA SECUNDIFLOTRA  
 LEUCOPHYLLUM C. THUNDERCLOUD  
 SIMMONDSIA CHINENSIS

**EXAMPLES OF APPROVED TREES :**

AUSTRALIAN WILLOW  
 CALIFORNIA FAN PALM  
 CHITALPA  
 GRAPE MYRTLE  
 PALO VERDE 'DESERT MUSEUM'  
 AFGHAN PINE  
 STRAWBERRY TREE  
 THORNLESS MESQUITE

GEIJERA PARVIFLORA  
 WASHINGTON FILIFERA  
 CHITALPA TASHKENTENIS  
 LAGERSTROEMIA INDICA  
 CERCIDIUM  
 PINUS ELДАРICA  
 ARBUTUS UNEDO  
 PROSOPIS CHILENSIS

NOT TO SCALE

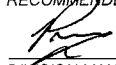
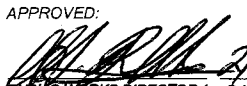
	RECOMMENDED:  DIVISION MANAGER      2/26/15 DATE	<b>CITY OF MORENO VALLEY</b> PUBLIC WORKS DEPARTMENT - CAPITAL PROJECTS DIVISION	STANDARD PLAN <b>MVSI-141B-0</b>
	APPROVED:  PUBLIC WORKS DIRECTOR / DATE CITY ENGINEER	<b>MEDIAN LANDSCAPE                  MEANDERING DESIGN NOTES</b>	

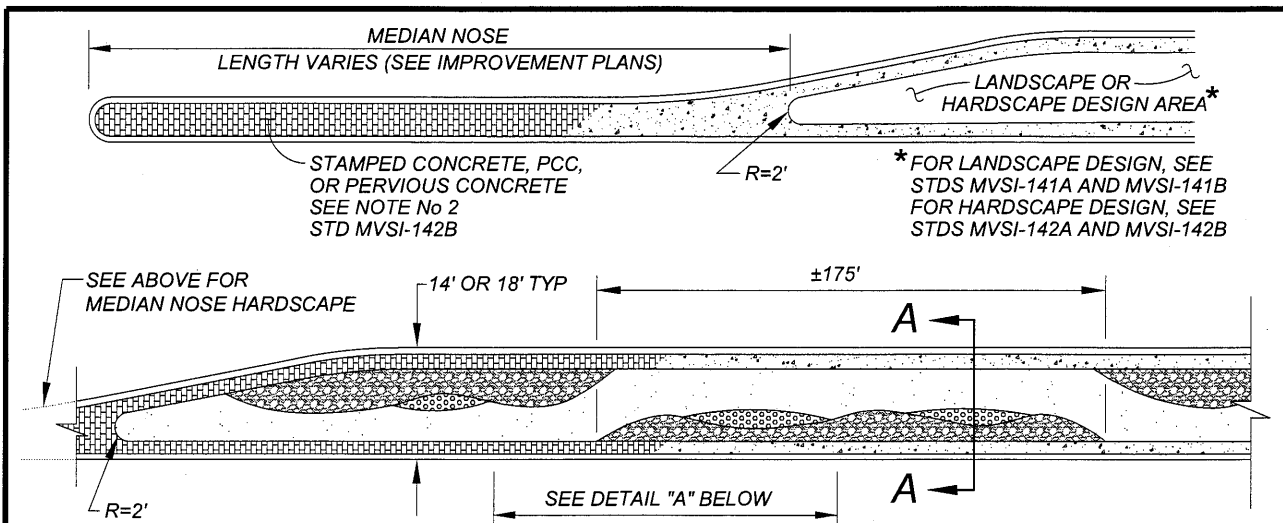

**TYPICAL LAYOUT / MEDIAN HARDSCAPE DESIGN**

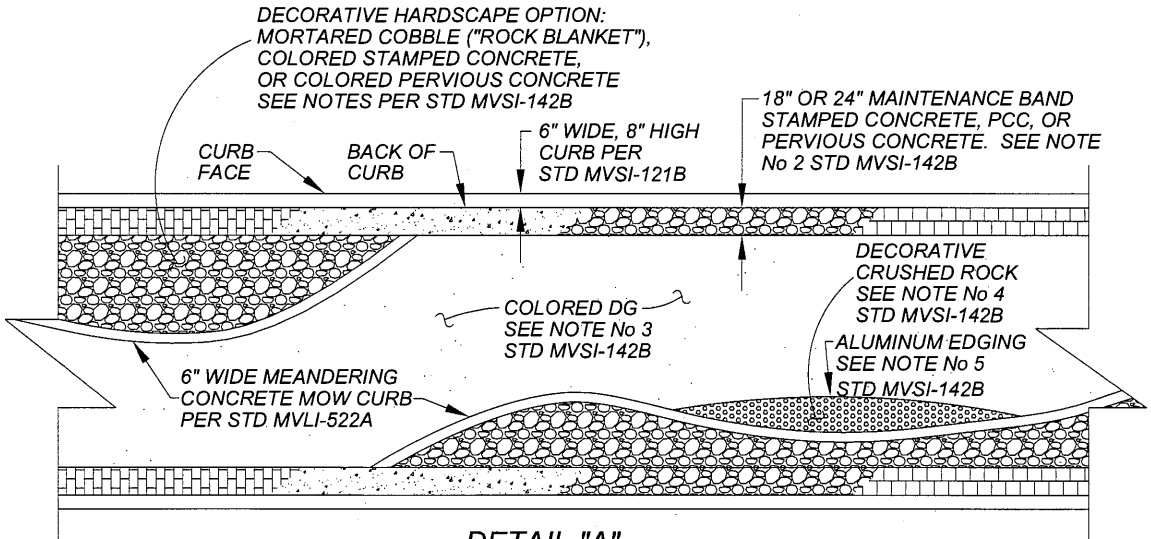

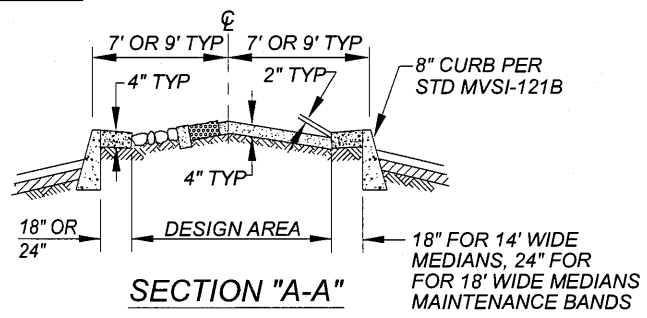

**DETAIL "A"**



**SECTION "A-A"**

NOTE: See MVSI-142B-1 FOR MEDIAN HARDSCAPE NOTES

NOT TO SCALE

	RECOMMENDED:  1-6-17 DIVISION MANAGER DATE	<b>CITY OF MORENO VALLEY</b> PUBLIC WORKS DEPARTMENT - CAPITAL PROJECTS DIVISION	<b>STANDARD PLAN</b> <b>MVSI-142A-1</b>
	APPROVED:  1/20/17 PUBLIC WORKS DIRECTOR / DATE CITY ENGINEER		
			SHEET 1 OF 2

REVISION 1: STD REVISED TO INCLUDE A MEANDERING DESIGN

**NOTES:**

- 1.) DECORATIVE HARDSCAPE OPTION SHALL BE MORTARED COBBLE ("ROCK BLANKET"), COLORED STAMPED CONCRETE, OR COLORED PERVIOUS CONCRETE PER APPROVED PLANS. COLOR AND PATTERN SHALL VARY FROM MAINTENANCE BANDS.
- 2.) MAINTENANCE BANDS AND MEDIAN NOSES SHALL BE BRICK PATTERN COLORED STAMPED CONCRETE, PCC, OR PERVIOUS CONCRETE, 4" THICK, 18" WIDE FOR 14' WIDE MEDIANS, AND 24" WIDE FOR 18' WIDE MEDIANS, AND PER APPROVED PLANS. THE MAINTENANCE BAND SHALL BE STAMPED BRICK PATTERN (SEE No 8) IF REQUIRED TO MATCH THE BRICK PATTERN OF EXISTING MEDIANS ADJACENT TO THE PROJECT. IF THE MAINTENANCE BAND IS NOT REQUIRED TO MATCH EXISTING MEDIANS, THE BAND MAY BE STAMPED CONCRETE WITH A GRAY COBBLE DESIGN, A BUFF SQUARE FLAGSTONE DESIGN, OR AS APPROVED BY THE CITY ENGINEER. ALTERNATIVELY THE BAND MAY BE PCC CLASS 560-C-3250, CURED WITH WHITE PIGMENTED CURING COMPOUND OVER 90% RELATIVE COMPACTED SUBGRADE, OR PERVIOUS CONCRETE (SEE No 9), AS APPROVED BY THE CITY ENGINEER.
- 3.) DECOMPOSED GRANITE (DG) SHALL BE 4" THICK WITH STABILIZER. COLOR SHALL BE "WHEAT", IN CONTRAST WITH ADJACENT COLORS, OR AS OTHERWISE APPROVED. INSTALL DG OVER WATER-PERMEABLE LINER OVER 90% RELATIVE COMPACTED SUBGRADE. AVAILABLE FROM DECORATIVE STONE SOLUTIONS, (800) 699-1878.
- 4.) DECORATIVE CRUSHED ROCK SHALL BE VARIABLE DIAMETER (3/8" MIN, 1" MAX) AND PLACED 4" THICK FROM DECORATIVE STONE SOLUTIONS, OR APPROVED EQUAL. COLOR SHALL BE "APACHE BROWN", IN CONTRAST WITH ADJACENT COLORS, OR AS OTHERWISE APPROVED. INSTALL CRUSHED ROCK OVER WATER-PERMEABLE LINER OVER 90% RELATIVE COMPACTED SUBGRADE.
- 5.) CLEANLINE ALUMINUM EDGING 1/8" x 5-1/2" MILL FINISH (NATURAL ALUMINUM) FROM PERMALOC CORPORATION, OR APPROVED EQUAL, SHALL BE USED TO SEPARATE THE ROCK FROM THE DG AREA. TOP OF EDGING SHALL BE FLUSH WITH TOP OF ROCK.
- 6.) 6" WIDE, 6" DEEP MEANDERING CONCRETE MOW CURB SHALL BE PER STD MVLI-522A-0.
- 7.) DECORATIVE HARDSCAPE OPTION MORTARED COBBLE ("ROCK BLANKET") SHALL USE ROCK THAT IS CLEAN, SMOOTH, AND OBTAINED FROM A SINGLE SOURCE. ROCK SHALL BE LIGHT GREY GRANITE COBBLE FROM KRC ROCK, OR APPROVED EQUAL, AND SHALL APPROXIMATELY MATCH IN COLOR, SIZE AND SHAPE OF ROCK BLANKETS IN THE GENERAL VICINITY. ROCK SHALL CONFORM TO THE FOLLOWING GRADING:

<u>ROCK SIZE (INCHES)</u>	<u>PERCENTAGE</u>
12	10
10	40
8	40
6	10

A SAMPLE OF THE ROCK SHALL BE SUBMITTED TO THE CITY ENGINEER FOR APPROVAL PRIOR TO DELIVERY OF THE ROCK TO THE PROJECT SITE. THE CONTRACTOR SHALL PROVIDE THE ENGINEER WITH A 6' x 6' TEST PANEL OF THE ROCK BLANKET FOR APPROVAL PRIOR TO INSTALLING THE ROCK BLANKET IN PLACE. ALL OTHER MATERIALS, SITE PREPARATION, AND PLACEMENT SHALL BE PER APPROVED PROJECT PLANS, PROJECT BID DOCUMENTS, AND PER SECTION 20-12 'ROCK BLANKET' OF THE CALTRANS STANDARD SPECIFICATIONS, LATEST VERSION.

- 8.) DECORATIVE HARDSCAPE OPTION COLORED STAMPED CONCRETE SHALL BE INSTALLED BY A QUALIFIED CONTRACTOR. THE CONTRACTOR SHALL SUBMIT FOR APPROVAL A SAMPLE OF THE STAMPED CONCRETE A MINIMUM OF 4 SF BY 4" THICK, OR SHALL INDICATE TWO LOCATIONS WITHIN A 10 MILE LIMIT FROM THE CITY WHERE THEIR PREVIOUS WORK CAN BE OBSERVED. CONCRETE WORK SHALL CONFORM TO THE APPLICABLE REQUIREMENTS OF SECTIONS 200, 201, AND 303 OF THE STANDARD SPECIFICATIONS FOR PUBLIC WORK CONSTRUCTION, LATEST EDITION, AND AS APPROVED BY THE CITY ENGINEER. STAMPED CONCRETE SHALL BE A MINIMUM OF 4" THICK. CONCRETE MIX SHALL BE PROPORTIONED USING 560-C-3250. AN AIR-ENTRAINING AGENT CONFORMING TO ASTM C260 AND/OR A NORMAL SET OR RETARDED SET WATER REDUCING ADMIXTURE CONFORMING WITH ASTM C494 MAY BE USED. CALCIUM CHLORIDE WILL NOT BE ALLOWED. THE SLUMP SHALL NOT EXCEED 4". THE COLORING MIXTURE FOR THE STAMPED CONCRETE SHALL BE INTEGRALLY MIXED. THE COLORING MIXTURE FOR THE STAMPED CONCRETE SHALL BE AS SPECIFIED ON THE APPROVED PLANS AND AS APPROVED BY THE CITY ENGINEER. A TRANSLUCENT CURING COMPOUND SHALL BE APPLIED UNIFORMLY TO THE CONCRETE IMMEDIATELY AFTER FINISHING. THE CONTRACTOR SHALL DELIVER TO THE CITY ENGINEER TWO LABELS FROM THE PACKAGES CONTAINING THE SELECTED COLORING AGENT USED IN THE COURSE OF THE SPECIFIED WORK. THE CONTRACTOR SHALL USE THE STAMPING TOOL SPECIFIED ON THE PLANS AND/OR AS APPROVED BY THE CITY ENGINEER.
- 9.) DECORATIVE HARDSCAPE OPTION COLORED PERVIOUS CONCRETE SHALL MEET THE REQUIREMENTS FOR PERVIOUS CONCRETE AND SUBGRADE OF SECTIONS 303-8 AND 201-1.1.6 OF THE STANDARD SPECIFICATIONS FOR PUBLIC WORKS CONSTRUCTION, LATEST EDITION. COLOR PER APPROVED PLANS.

NOT TO SCALE

	RECOMMENDED:  DIVISION MANAGER DATE: 2/26/15	<b>CITY OF MORENO VALLEY</b> PUBLIC WORKS DEPARTMENT - CAPITAL PROJECTS DIVISION	
	APPROVED:  PUBLIC WORKS DIRECTOR/ CITY ENGINEER DATE: 2/26/15	<b>MEDIAN HARDSCAPE MEANDERING DESIGN NOTES</b>	

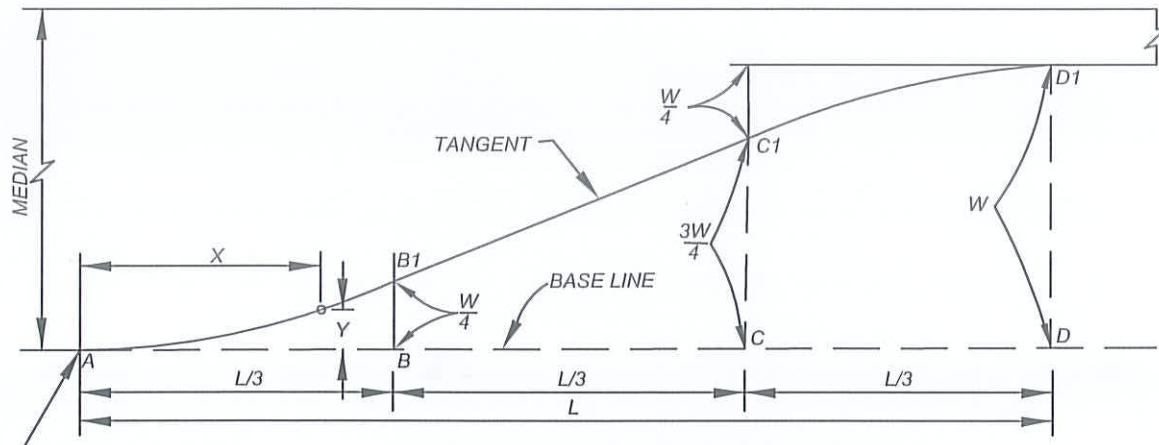



$$Y = 2.25W \left(\frac{X}{L}\right)^2 \quad (\text{FOR A-B1 AND C1-D1 CURVES})$$
  
 L = LENGTH OF TAPER  
 W = MAXIMUM OFFSET DISTANCE FROM BASELINE  
 X = DISTANCE ALONG BASELINE FROM ORIGIN  
 Y = OFFSET FROM BASELINE

L	DISTANCE X												
	60'	5'	10'	15'	20'	25'	30'	35'	40'	45'	50'	55'	60'
72'	6'	12'	18'	24'	30'	36'	42'	48'	54'	60'	66'	72'	
90'	7.5'	15'	22.5'	30'	37.5'	45'	52.5'	60'	67.5'	75'	82.5'	90'	
120'	10'	20'	30'	40'	50'	60'	70'	80'	90'	100'	110'	120'	
180'	15'	30'	45'	60'	75'	90'	105'	120'	135'	150'	165'	180'	
W	OFFSET Y												
	10'	0.16'	0.62'	1.41'	2.50'	3.75'	5.00'	6.25'	7.50'	8.59'	9.38'	9.84'	10.00'
	11'	0.17'	0.69'	1.55'	2.75'	4.13'	5.50'	6.88'	8.25'	9.45'	10.31'	10.83'	11.00'
	12'	0.19'	0.75'	1.69'	3.00'	4.50'	6.00'	7.50'	9.00'	10.31'	11.25'	11.81'	12.00'
	22'	0.34'	1.38'	3.09'	5.50'	8.25'	11.00'	13.75'	16.50'	18.91'	20.63'	21.66'	22.00'
	24'	0.38'	1.50'	3.38'	6.00'	9.00'	12.00'	15.00'	18.00'	20.63'	22.50'	23.63'	24.00'

**NOTES:**

1.) TO DETERMINE OFFSET DISTANCE FOR ANY LENGTH OF TAPER USE THE FORMULA  $Y=2.25W(X/L)^2$  FOR THE PORTIONS A-B1 AND C1-D1 WHICH ARE PARABOLIC CURVES. THE PORTION B1-C1 IS A TANGENT. WHEN THE BASE LINE IS CURVED, THE OFFSETS ARE APPLIED TO THE CURVED BASE LINE, AND B1-C1 IS NO LONGER A TANGENT.

NOT TO SCALE

	RECOMMENDED:  DIVISION MANAGER DATE 1/21/14	<b>CITY OF MORENO VALLEY</b> PUBLIC WORKS DEPARTMENT - CAPITAL PROJECTS DIVISION  <b>MEDIAN TAPER</b>	STANDARD PLAN <b>MVSI-143-0</b>
	APPROVED:  PUBLIC WORKS DIRECTOR / DATE 1/29/14 CITY ENGINEER		SHEET 1 OF 1

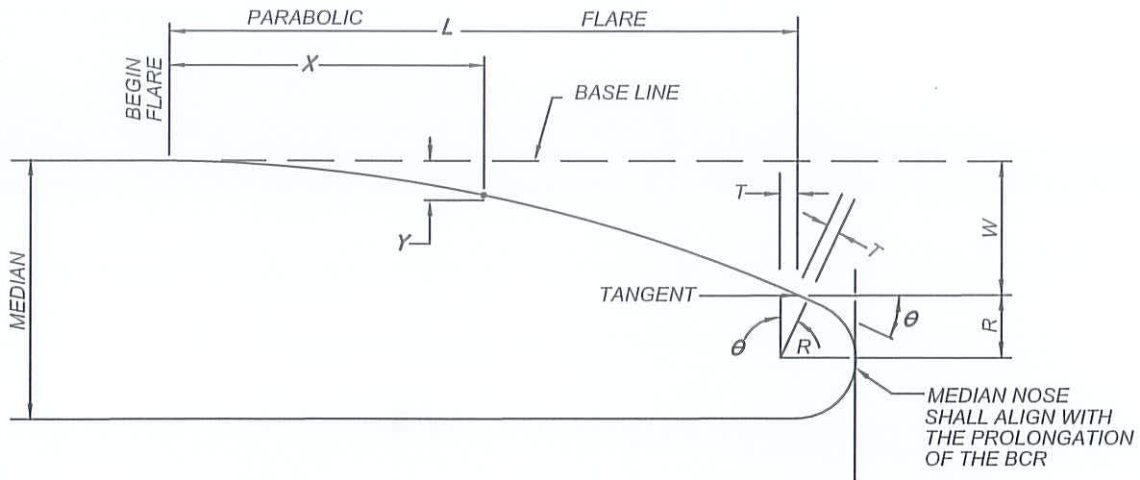

$$Y = W \left( \frac{X}{L} \right)^2$$

L=LENGTH OF FLARE IN FEET, PER PLAN  
 W=MAXIMUM OFFSET DISTANCE IN FEET, PER PLAN  
 X=DISTANCE ALONG BASELINE IN FEET  
 Y=OFFSET FROM BASELINE IN FEET

$$\tan \theta = \frac{2W}{L}$$

$$T = R \tan \frac{\theta}{2}$$

T=TANGENT  
 R=RADIUS OF NOSE IN FEET  
 θ= MAXIMUM FLARE DEFLECTION ANGLE

**OFFSET Y**

$\frac{X}{L}$	10'	15'	20'	25'	30'	40'	45'	50'	60'	70'	75'	80'	90'	100'
---------------	-----	-----	-----	-----	-----	-----	-----	-----	-----	-----	-----	-----	-----	------

**FOR W/L=1:5**

25'	0.80'	1.80'	3.20'	5.00'										
50'	0.40'	0.90'	1.60'	2.50'	3.60'	6.40'	8.10'	10.00'						

**FOR W/L=1:10**

50'	0.20'	0.45'	0.80'	1.25'	1.80'	3.20'	4.05'	5.00'						
100'	0.10'	0.23'	0.40'	0.63'	0.90'	1.60'	2.03'	2.50'	3.60'	4.90'	5.63'	6.40'	8.10'	10.00'

**FOR W/L=1:15**

45'	0.15'	0.33'	0.59'	0.93'	1.33'	2.37'	3.00'							
75'	0.09'	0.20'	0.36'	0.56'	0.80'	1.42'	1.80'	2.22'	3.20'	4.36'	5.00'			
90'	0.07'	0.17'	0.30'	0.46'	0.67'	1.19'	1.50'	1.85'	2.67'	3.63'	4.17'	4.74'	6.00'	

**NOTES:**

1.) IF STATION OF RADIUS POINT IS NOT GIVEN ON PLAN, TANGENT, T, MAY BE IGNORED. PLANS SHALL SPECIFY L AND W.

NOT TO SCALE

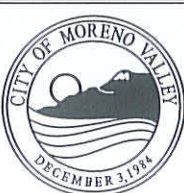

RECOMMENDED:  
 [Signature] / 1/21/14  
 DIVISION MANAGER / DATE  
 APPROVED:  
 [Signature] / 1/29/14  
 PUBLIC WORKS DIRECTOR / DATE  
 CITY ENGINEER

**CITY OF MORENO VALLEY**  
 PUBLIC WORKS DEPARTMENT - CAPITAL PROJECTS DIVISION

**MEDIAN FLARE**

STANDARD PLAN  
**MVSI-144-0**

SHEET 1 OF 1



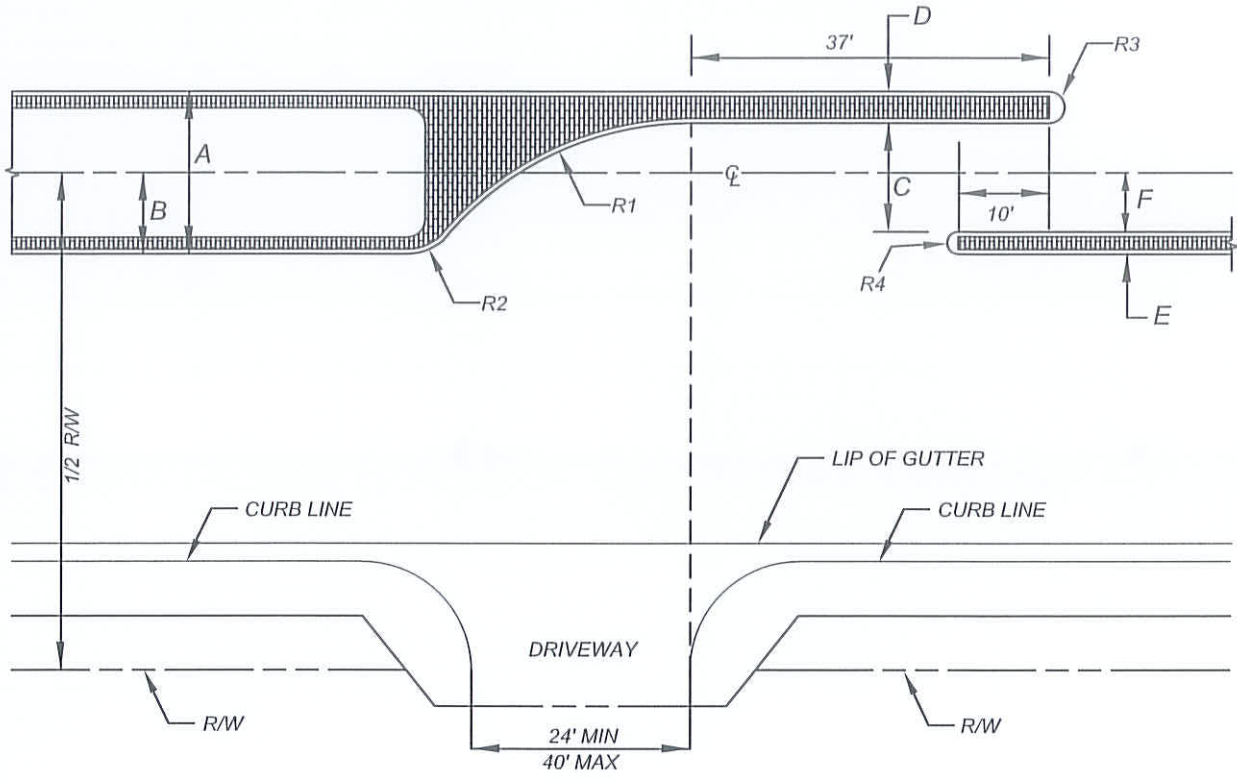

**PLAN VIEW**

FULL RW	1/2 R/W	A	B	C	D	E	F
110'	55'	18'	9'	12'	3.5'	2.5'	6.5'
110'*	55'*	14'	7'	11'	1.5'	1.5'	5.5'
114'	57'	18'	9'	12'	3.5'	2.5'	6.5'
120'	60'	14'	7'	11'	1.5'	1.5'	5.5'
130'	65'	14'	7'	11'	1.5'	1.5'	5.5'
134'	67'	18'	9'	12'	3.5'	2.5'	6.5'

CURVE DATA			
CURVE	RADIUS	DELTA	LENGTH
R1	35.00'	51°00'00"	31.27'
R2	6.00'	40°00'00"	4.23'
R3	1.75'	180°00'00"	5.50'
R4	1.25'	180°00'00"	3.93'

**NOTES:**

- 1.) TO BE USED, AS APPLICABLE, WITH STDS MVSI-101A-0 & MVSI-101B-0, MVSI-102A-0 & MVSI-102B-0, MVSI-103A-0 - MVSI-103C-0 AND MVSI-121B-0. FOR LANDSCAPED MEDIAN REFER TO STDS MVSI-141-0, MVSI-142A-0, AND MVSI-142B-0.
- 2.) FOR COMMERCIAL DRIVEWAY APPROACH REFER TO STDS MVSI-112A-0 ~ MVSI-112D-0.
- 3.) SIGNAGE PER THE CA MUTCD LATEST EDITION.
- 4.) TRUCK TURNING DIAGRAMS SHALL BE SUBMITTED TO SHOW NO CONFLICT WITH DRIVEWAY OR MEDIAN STRUCTURES.

\* PERRIS BOULEVARD ONLY

NOT TO SCALE

	RECOMMENDED:  DIVISION MANAGER DATE: 1/21/14	<h2 style="margin: 0;">CITY OF MORENO VALLEY</h2> <p style="margin: 0;">PUBLIC WORKS DEPARTMENT - CAPITAL PROJECTS DIVISION</p>	
	APPROVED:  PUBLIC WORKS DIRECTOR / CITY ENGINEER DATE: 1/29/14	<h3 style="margin: 0;">RESTRICTED LEFT TURN MEDIAN OPENING</h3>	STANDARD PLAN <h3 style="margin: 0;">MVSI-145-0</h3>

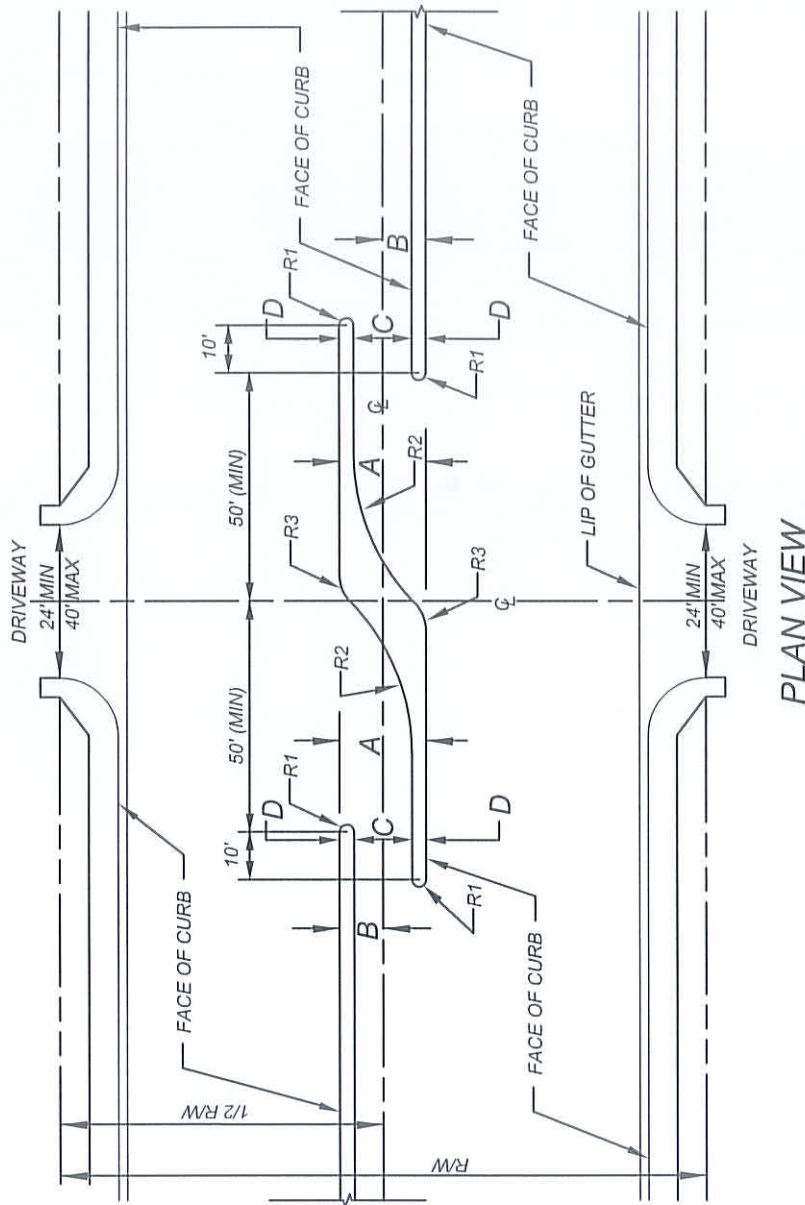

PLAN VIEW

CURVE DATA			
	RADIUS	DELTA	LENGTH
WIDTH A	14'	14'	18'
R1	18'	180°	2.35'
R2	1.5'	39°	30.95'
R3	45'	44°	6.17'
	8'	39°	5.5'

\* PERRIS BOULEVARD ONLY

**NOTES:**

- 1.) TO BE USED, AS APPLICABLE, WITH STDS MVSI-101A-0, MVSI-101B-0, MVSI-102A-0, MVSI-102B-0, MVSI-103A-0 ~ MVSI-103C-0, MVSI-121A-0 AND MVSI-121B-0. FOR LANDSCAPED MEDIANS REFER TO STDS MVSI-141-0, MVSI-142A-0 AND MVSI-142B-0.
- 2.) FOR COMMERCIAL DRIVEWAY APPROACH REFER TO STDS MVSI-112A-0 ~ MVSI-112D-0.
- 3.) SIGNAGE PER THE CA MUTCD LATEST EDITION.
- 4.) TRUCK TURNING DIAGRAMS SHALL BE SUBMITTED TO SHOW NO CONFLICT WITH DRIVEWAY OR MEDIAN STRUCTURES.

FULL R/W	1/2 R/W	A	B	C	D
110'	55'	18'	9'	12'	3'
110'*	55'*	14'	7'	11'	1.5'
114'	57'	18'	9'	12'	3'
120'	60'	14'	7'	11'	1.5'
130'	65'	14'	7'	11'	1.5'
134'	67'	18'	9'	12'	3'

NOT TO SCALE



RECOMMENDED:  
  
 DIVISION MANAGER DATE 1/21/14  
 APPROVED:  
  
 PUBLIC WORKS DIRECTOR / CITY ENGINEER DATE 1/29/14

**CITY OF MORENO VALLEY**  
 PUBLIC WORKS DEPARTMENT - CAPITAL PROJECTS DIVISION

**ALIGNED OPPOSITE  
 DRIVEWAYS RESTRICTED  
 LEFT TURN MEDIAN**

STANDARD PLAN  
**MVSI-146-0**

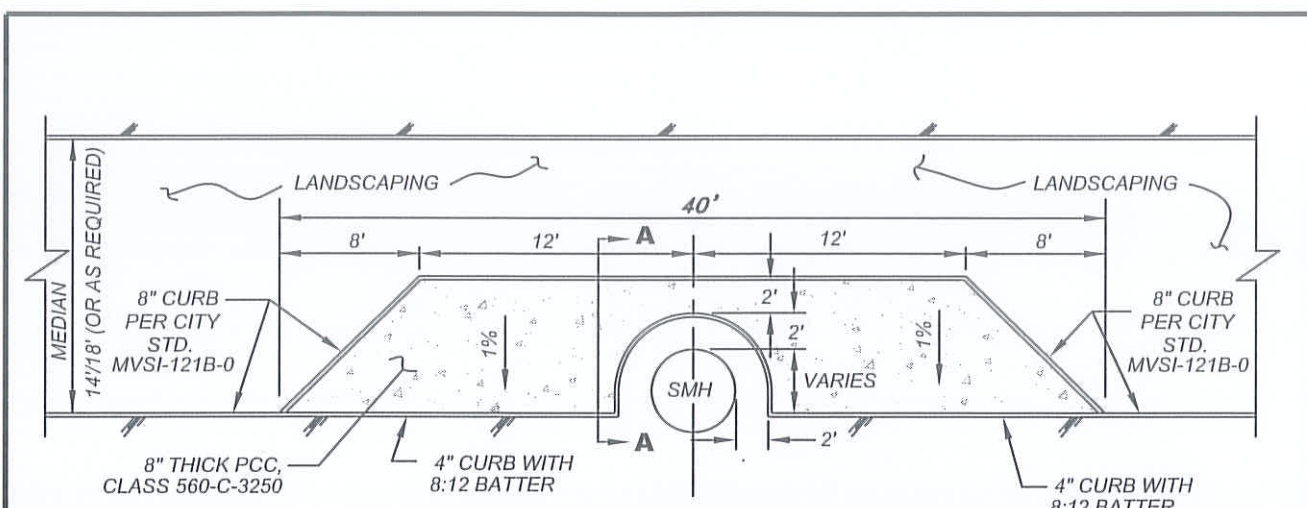

**CASE I**

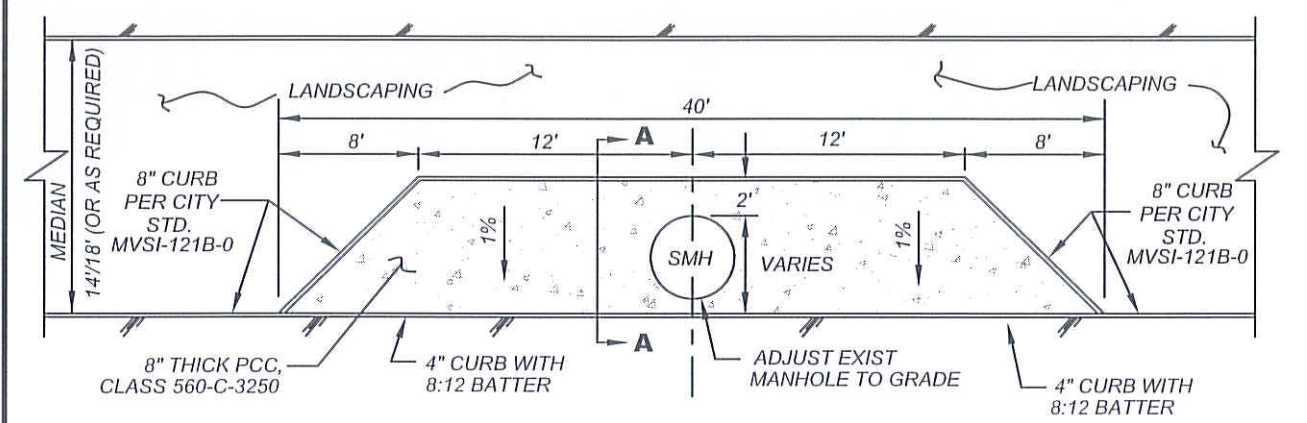

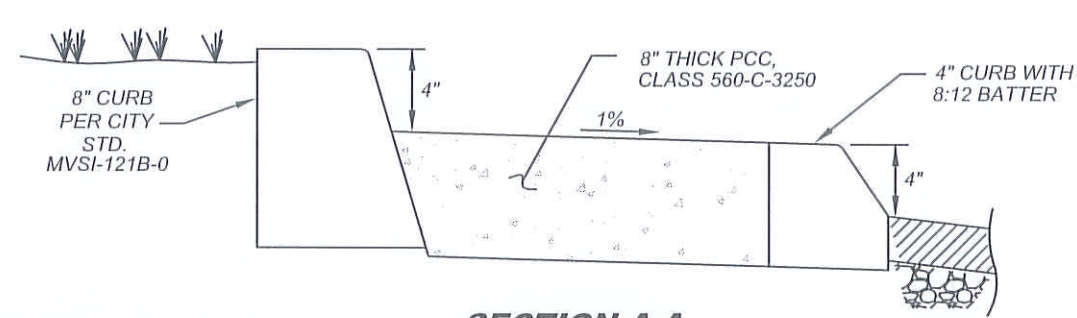

**CASE II**

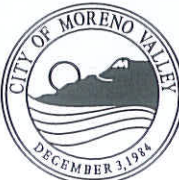

**SECTION A-A**

NOT TO SCALE

	RECOMMENDED:  DIVISION MANAGER DATE: 1/21/14	<b>CITY OF MORENO VALLEY</b> PUBLIC WORKS DEPARTMENT - LAND DEVELOPMENT DIVISION  <b>MANHOLE/CURB CONFLICT WITH MEDIAN ACCESS</b>	STANDARD PLAN <b>MVSI-147A-0</b>
	APPROVED:  PUBLIC WORKS DIRECTOR / CITY ENGINEER DATE: 1/29/14		SHEET 1 OF 2



**NOTES:**

- 1.) SEE STD. MVSI-121B-0 FOR TYPE "8A" CURB.
- 2.) ALL LANDSCAPE, IRRIGATION, AND DRAINAGE PLANS AND DEVICES SHALL BE APPROVED BY THE CITY PRIOR TO INSTALLATION.
- 3.) THE LANDSCAPE PLAN SHALL MINIMIZE RUNOFF TO THE PAVEMENT.
- 4.) MODIFICATIONS TO THIS STANDARD MAY BE MADE BY THE CITY ENGINEER.
- 5.) CONSTRUCT TRANSVERSE AND LONGITUDINAL WEAKENED - PLANE JOINTS IN CONCRETE PAD AT APPROXIMATELY 10' INTERVALS.
- 6.) CONCRETE SHALL BE CLASS 560-C-3250. AN AIR-ENTRAINING AGENT CONFORMING TO ASTM C260 AND/OR A NORMAL SET OR RETARDED SET WATER REDUCING ADMIXTURE CONFORMING WITH ASTM C494 MAY BE USED. CALCIUM CHLORIDE WILL NOT BE ALLOWED. THE SLUMP SHALL NOT EXCEED 4".
- 7.) THE CONTRACTOR FOR THE STAMPED CONCRETE SHALL PROVIDE CONCLUSIVE PROOF THAT THEY ARE QUALIFIED TO AND HAS PREVIOUSLY PRODUCED SUCH TEXTURED PAVING AND CAN COMPLY WITH THE PROVISIONS SPECIFIED HEREIN. THE CONTRACTOR SHALL ALSO STIPULATE THAT THEY WILL NOT INFRINGE ON ANY APPLICABLE PATENT RIGHTS AND WILL HOLD THE CITY HARMLESS FROM ANY DAMAGES ARISING FROM PATENT INFRINGEMENT.
- 8.) THE CONTRACTOR SHALL SUBMIT A SAMPLE OF THE SPECIFIED STAMPED CONCRETE A MINIMUM OF 4 S.F. BY 4 INCHES OR SHALL INDICATE TWO LOCATIONS WITHIN A 10 MILE LIMIT FROM THE CITY, WHERE THEIR PRIOR WORK OF SIMILAR STAMPED CONCRETE CAN BE OBSERVED. THE SAMPLES SHALL MEET THE APPROVAL OF THE CITY ENGINEER AND ALL WORK SHALL MATCH THE APPROVED SAMPLES.
- 9.) THE COLORING MIXTURE FOR THE STAMPED CONCRETE SHALL BE INTEGRALLY MIXED.
- 10.) THE COLORING MIXTURE FOR THE STAMPED CONCRETE SHALL BE "BRICK RED" NO. 160, BY DAVIS COLORS, OR APPROVED EQUAL, MATCHING THE CITY ENGINEER'S SELECTED AND APPROVED SAMPLE PATTERN. A TRANSLUCENT CURING COMPOUND SHALL BE APPLIED UNIFORMLY TO THE CONCRETE IMMEDIATELY AFTER FINISHING.
- 11.) THE CONTRACTOR SHALL DELIVER TO THE CITY ENGINEER (FOR APPROVAL PRIOR TO INSTALLATION) TWO LABELS FROM THE PACKAGES CONTAINING THE SELECTED COLORING AGENT USED IN THE COURSE OF THE SPECIFIED WORK.
- 12.) FOR CASE I, MH IN CURB LINE, THE CONTRACTOR SHALL CONSTRUCT 4" HIGH CURB AROUND MANHOLE RIM WITH A 2' OFFSET
- 13.) FOR CASE II, MH WITHIN MEDIAN, THE CONTRACTOR SHALL RAISE MANHOLE RIM TO PROPOSED GRADE OF MEDIAN HARDSCAPE.

NOT TO SCALE

	RECOMMENDED:  DIVISION MANAGER	DATE 11/21/14	<b>CITY OF MORENO VALLEY</b> PUBLIC WORKS DEPARTMENT - LAND DEVELOPMENT DIVISION	STANDARD PLAN
	APPROVED:  PUBLIC WORKS DIRECTOR / CITY ENGINEER	DATE 11/29/14		<b>MANHOLE/CURB CONFLICT WITH MEDIAN ACCESS</b>
				SHEET 2 OF 2

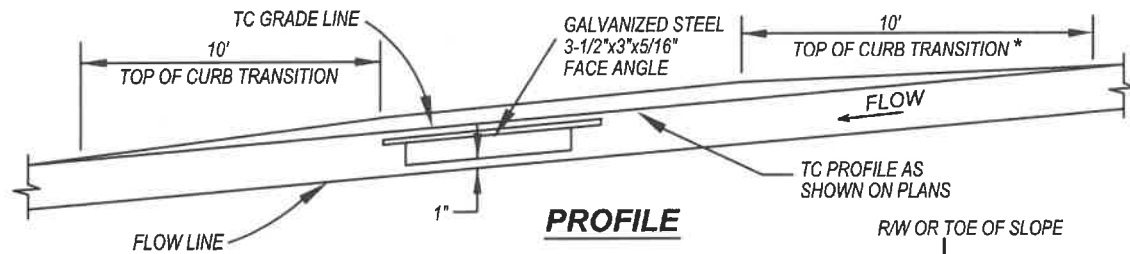
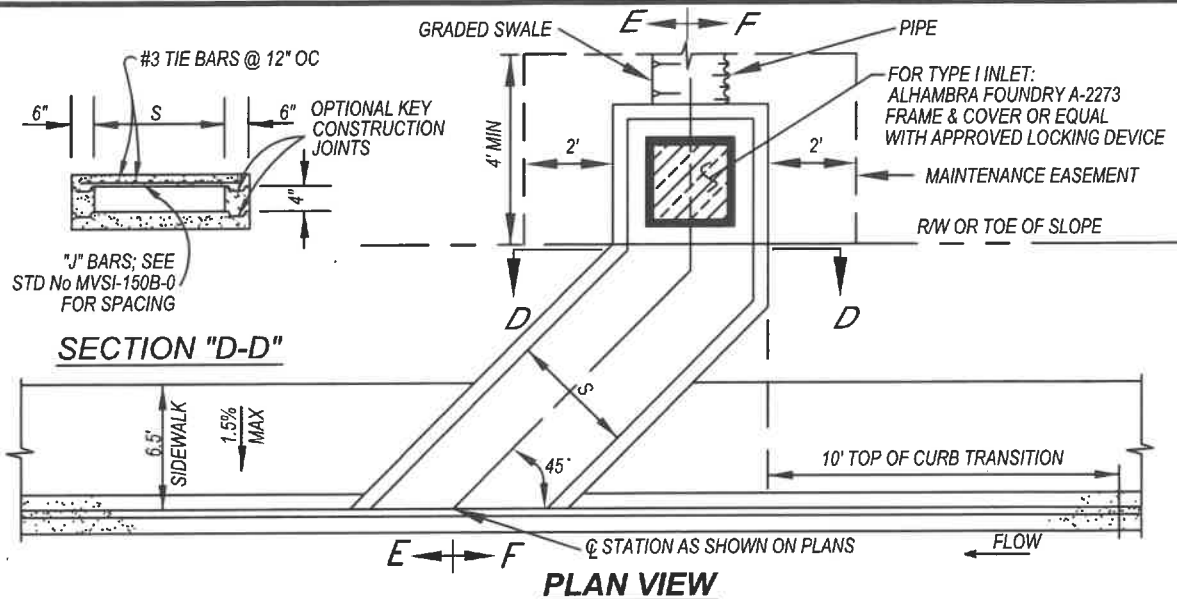

**NOTES:**

- 1) SPAN "S" AND HEIGHT OF OPENING AND CURB FACE HEIGHT AT CULVERT SHALL BE NOTED ON PLANS.
- 2) SEE STD PLAN No MVS1-150B FOR DETAILS AND NOTES.
- 3) CONCRETE SHALL BE CLASS 560-C-3250.
- 4) FACE ANGLE SHALL BE ANCHORED BY FULL PENETRATION WITH A 3-5/8" x 6-3/8" STEEL STUD OR BUTT WELD.
- 5) UNLESS OTHERWISE SPECIFIED, STANDARD FRAME AND COVER SHALL BE ALHAMBRA FOUNDRY GALVANIZED PIPE OR APPROVED EQUAL.
- 6) 1 INCH STEEL CLEARANCE MINIMUM FROM FACE OF CONCRETE.
- 7) TOP OF INLET STRUCTURE TO MATCH ADJACENT SLOPE.
- 8) SIDEWALK CROSS SLOPE SHALL NOT EXCEED 1.5% PER ADA REQUIREMENTS.

TOP OF CURB TRANSITION IS REQUIRED FOR \* 6" CURBS OR 8" CURBS WITH S > 4.0'.

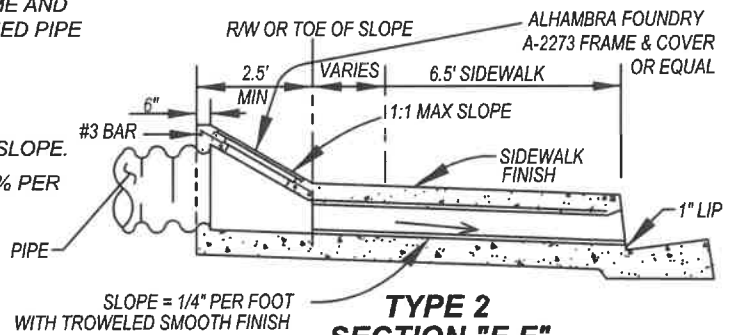
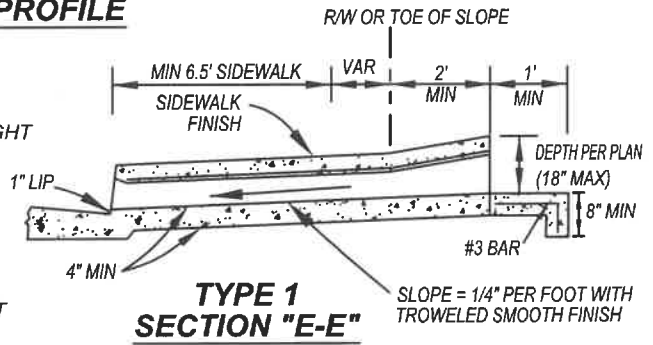

	RECOMMENDED: <i>Henrygo</i> 8/14/19 DIVISION MANAGER DATE	<h2 style="margin: 0;">CITY OF MORENO VALLEY</h2> <p style="margin: 0;">PUBLIC WORKS DEPARTMENT - CAPITAL PROJECTS DIVISION</p>	STANDARD PLAN <b>MVSI-150A-0</b>
	APPROVED: <i>M. Lopez</i> 10/11/19 PUBLIC WORKS DIRECTOR / DATE CITY ENGINEER	<h3 style="margin: 0;">PARKWAY CULVERT</h3>	SHEET 1 OF 2



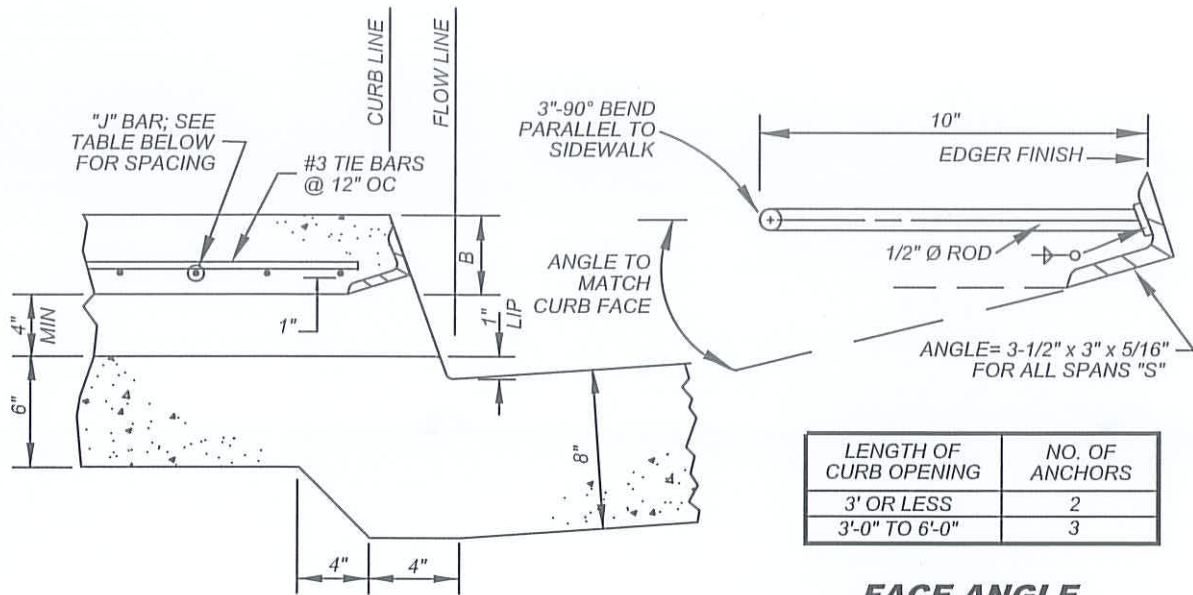

**OUTLET DETAIL**

**FACE ANCHOR DETAIL**

LENGTH OF CURB OPENING	NO. OF ANCHORS
3' OR LESS	2
3'-0" TO 6'-0"	3

SPAN "S"	B	STEEL SCHEDULE J-BARS		
		SIZE	SPACING C-C	LENGTH
2'-0"	3"	#3	7"	2'-9"
2'-6"	3"	#3	7"	3'-3"
3'-0"	3"	#3	7"	3'-9"
3'-6"	3"	#3	6"	4'-3"
4'-0"	3"	#3	5"	4'-9"
4'-6"	4"	#3	6-1/2"	5'-3"
5'-0"	4"	#3	5"	5'-9"
5'-6"	4"	#3	4"	6'-3"
6'-0"	4"	#3	3-1/2"	6'-9"

**STEEL SCHEDULE TABLE**

**NOTES:**

- 1.) FLOOR OF PARKWAY CULVERT SHALL HAVE A SMOOTH TROWELED FINISH.
- 2.) ALL EXPOSED METAL SHALL BE GALVANIZED AFTER FABRICATION.
- 3.) HEIGHT OF CURB OPENING FOR PARKWAY CULVERT WILL VARY WITH TYPE OF CURB.
- 4.) SPAN "S" AND HEIGHT OF CURB OPENING WILL BE DETERMINED FROM THE REQUIRED HYDRAULIC CAPACITY AND LIMITED TO THE DIMENSION IN STEEL SCHEDULE TABLE.
- 5.) REINFORCING STEEL SHALL BE 1" CLEAR TO INSIDE OF CULVERT UNLESS OTHERWISE SPECIFIED.
- 6.) CONSTRUCT PCC WALK AS SPECIFIED ON PLAN. THE CONTRACT PRICE PAID FOR PCC SIDEWALK ITEM SHALL INCLUDE WALK CONSTRUCTED IN CONJUNCTION WITH PARKWAY CULVERT.
- 7.) TYPE, DIMENSIONS, AND ELEVATIONS PER IMPROVEMENT PLAN.

NOT TO SCALE



RECOMMENDED:  
 [Signature] / 1/21/14  
 DIVISION MANAGER DATE  
 APPROVED:  
 [Signature] / 1/29/14  
 PUBLIC WORKS DIRECTOR / DATE  
 CITY ENGINEER



**CITY OF MORENO VALLEY**  
 PUBLIC WORKS DEPARTMENT - CAPITAL PROJECTS DIVISION

**PARKWAY CULVERT  
 DETAILS AND NOTES**

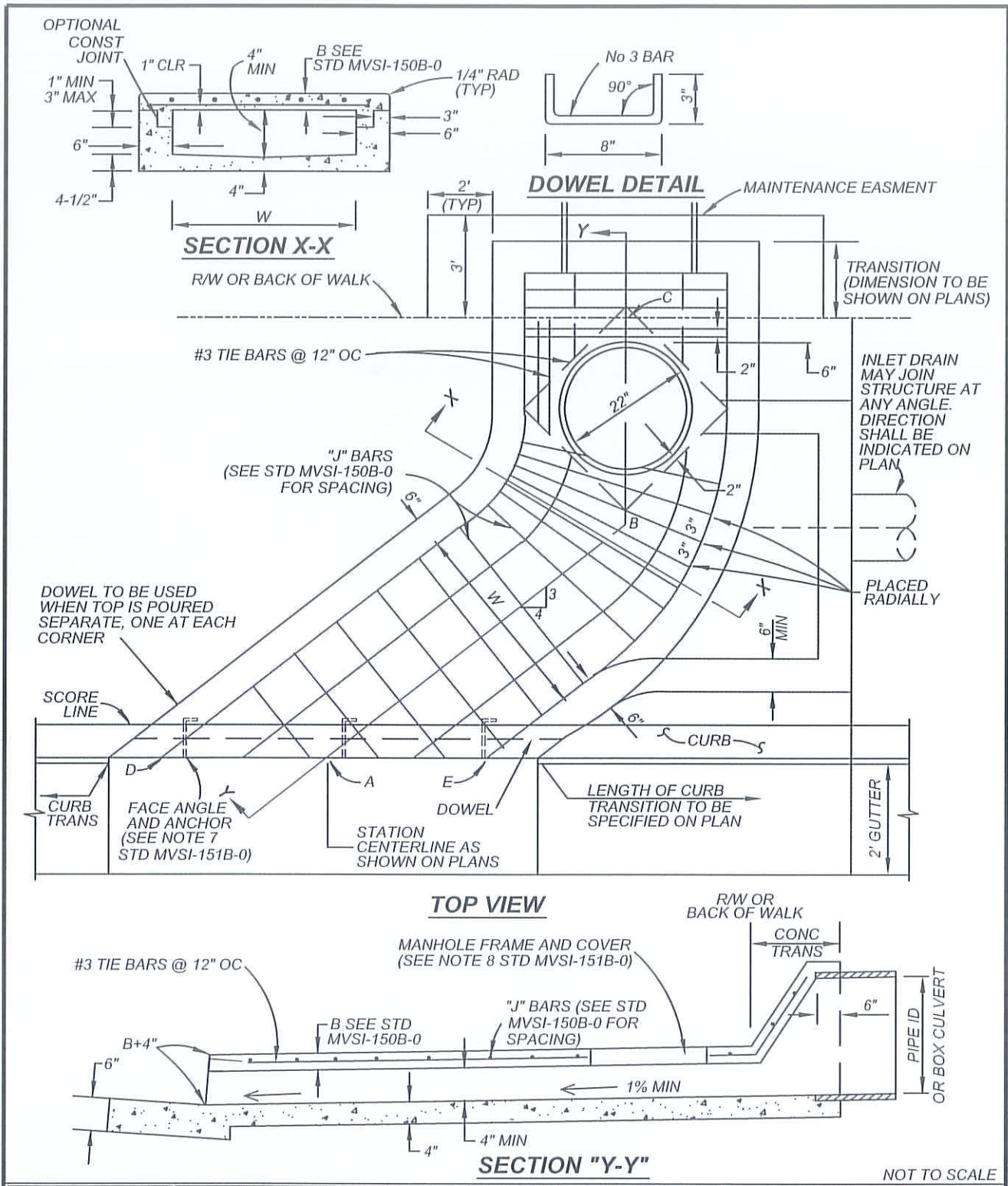
STANDARD PLAN  
**MVSI-150B-0**



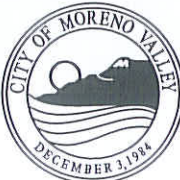

NOT TO SCALE

	RECOMMENDED:  DIVISION MANAGER DATE 1/21/14	<b>CITY OF MORENO VALLEY</b> PUBLIC WORKS DEPARTMENT - CAPITAL PROJECTS DIVISION	STANDARD PLAN <b>MVSI-151A-0</b>
	APPROVED:  PUBLIC WORKS DIRECTOR / DATE CITY ENGINEER 1/29/14		
			SHEET 1 OF 2

**NOTES:**

- 1.) CONCRETE SHALL BE CLASS 560-C-3250 PCC, CURED WITH WHITE PIGMENTED CURING COMPOUND.
- 2.) THE SURFACE OF ALL EXPOSED CONCRETE SHALL CONFORM IN SLOPE, GRADE, FINISH, AND SCORING TO EXISTING CURB, GUTTER AND WALK ADJACENT TO THE STRUCTURE.
- 3.) CURVATURE OF CONCRETE SURFACE SHALL BE SHAPED BY CURVED FORMS AND SHALL NOT BE SHAPED BY PLASTERING.
- 4.) THE INVERT OF THE STRUCTURE SHALL BE GIVEN A STEEL TROWELED FINISH AND CONSTRUCTED ON A STRAIGHT GRADE FROM THE INLET INVERT THROUGH POINT B TO POINT A.
- 5.) DIMENSIONS (UNLESS OTHERWISE INDICATED ON THE PROJECT PLANS):  
AB = 5'  
BC = 3'  
DE = 5'  
W = 3'
- 6.) DOWELS SHALL BE REQUIRED AT EACH CORNER AND AT 2 FEET OC (MAX) WHEN THE TOP SLAB IS CONSTRUCTED SEPARATELY. WHEN THE TOP SLAB IS CONSTRUCTED MONOLITHIC WITH ADJACENT SIDEWALK, THE DOWELS MAY BE OMITTED.
- 7.) INSTALL FACE ANGLE AND ANCHORS AT THE OUTLET OF THE STRUCTURE IN CONFORMANCE WITH STANDARD PLAN No MVS-150B-0.
- 8.) INSTALL CATCH BASIN MANHOLE FRAME AND COVER CONFORMING TO STANDARD MVFE-300E-0.

NOT TO SCALE

	RECOMMENDED:  1/21/14 DIVISION MANAGER DATE	<b>CITY OF MORENO VALLEY</b> PUBLIC WORKS DEPARTMENT - CAPITAL PROJECTS DIVISION	STANDARD PLAN
	APPROVED:  1/29/14 PUBLIC WORKS DIRECTOR/ CITY ENGINEER DATE		<b>SIDEWALK OUTLET STRUCTURE NOTES</b>
			SHEET 2 OF 2



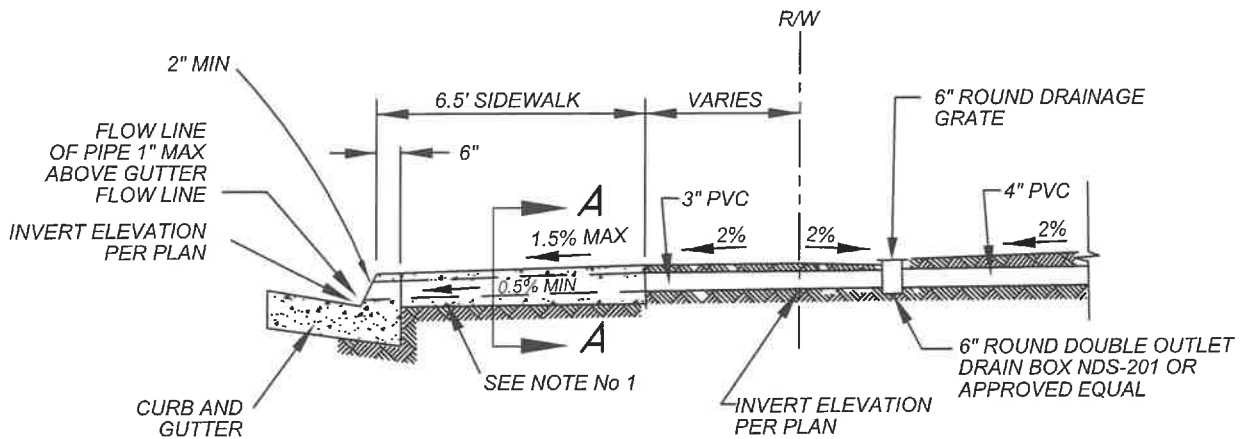

**ELEVATION**

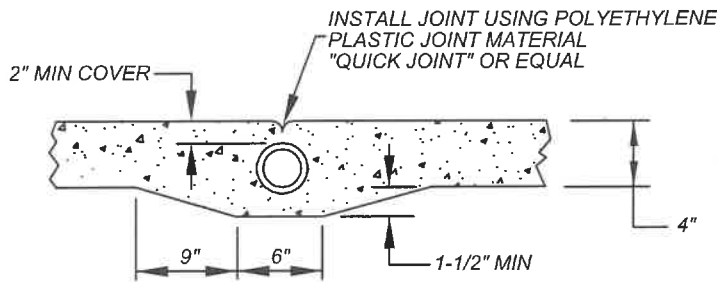

**SECTION "A-A"**  
**SIDEWALK**

**NOTES:**

- 1) DRAINS SHALL BE 3 INCH DIA PVC PIPE (SCHEDULE 40) OR RECTANGULAR CAST IRON BOX FOR 6 INCH CURB FACE AND 4 INCH DIA PVC PIPE (SCHEDULE 40) OR RECTANGULAR CAST IRON BOX FOR 8 INCH CURB FACE. PIPE MUST BE CONTINUOUS, NO JOINTS ALLOWED WITHIN CONCRETE SIDEWALK.
- 2) THE CURB SHALL BE CORED FOR ALL DRAIN PIPES.
- 3) THE NUMBER OF PIPES AT ANY LOCATION SHALL NOT EXCEED 4 @ 12" OC.
- 4) FOR ALL SINGLE FAMILY RESIDENTIAL LOTS AS APPROVED BY THE CITY ENGINEER.

NOT TO SCALE

	RECOMMENDED: <i>Harvey</i> 7/16/19 DIVISION MANAGER DATE	<b>CITY OF MORENO VALLEY</b> PUBLIC WORKS DEPARTMENT - CAPITAL PROJECTS DIVISION	
	APPROVED: <i>M. Wolf</i> 10/16/19 PUBLIC WORKS DIRECTOR / DATE CITY ENGINEER	<b>CURB DRAIN - RESIDENTIAL</b>	
			SHEET 1 OF 1

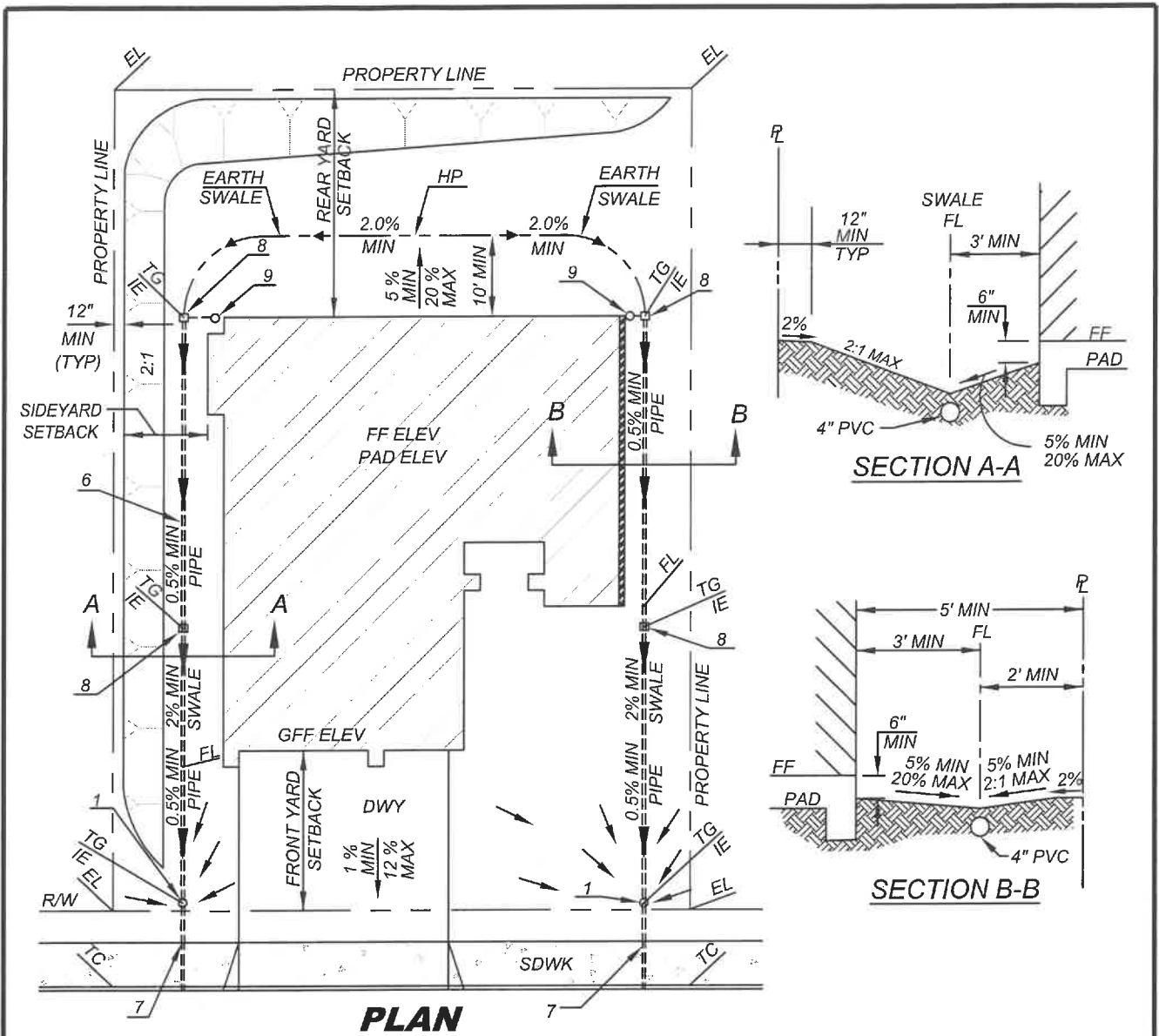

**NOTES:**

- 1.) 6 INCH ROUND NDS-201 DOUBLE OUTLET DRAIN BOX AND DRAINAGE GRATE, OR APPROVED EQUAL.
- 2.) ALL FITTINGS BY: NDS, INC (OR EQUAL)
- 3.) DO NOT GLUE GRATE OR RISER TO PIPE.
- 4.) GLUE SHALL BE "IPS WELD ON" # 773 SOLVENT.
- 5.) USE TEE WITH 90° SWEEP WHEN CONNECTING GRATE OR CLEAN-OUT TO AREA DRAIN SYSTEM.
- 6.) COMPLETE YARD DRAIN SYSTEM.
- 7.) CONSTRUCT YARD DRAIN AND CLEAN-OUT PER STD MVSI-152.
- 8.) TYPICAL AREA DRAIN PER STD MVSI-153B.
- 9.) TYPICAL DOWNSPOUT PER STD MVSI-153C.
- 10.) SEE STD MVSI-160B-0 GRADING REQUIREMENTS.

**LEGEND:**

- 4" PVC PIPE
- FLOW LINE
- ===== DEEPENED FOOTINGS, AS REQUIRED
- 6" DRAIN BOX AND GRATE
- AREA DRAIN ASSEMBLY (SEE STD MVSI-153B)

NOT TO SCALE

	RECOMMENDED: <i>MOL</i> 7/31/19 DIVISION MANAGER      DATE	<h2 style="margin: 0;">CITY OF MORENO VALLEY</h2> <p style="margin: 0;">PUBLIC WORKS DEPARTMENT - LAND DEVELOPMENT DIVISION</p>	STANDARD PLAN <b>MVSI-153A-1</b>
	APPROVED: <i>M. W. ...</i> 7/30/19 PUBLIC WORKS DIRECTOR / DATE CITY ENGINEER	<h3 style="margin: 0;">TYPICAL LOT DRAINAGE AND YARD DRAIN</h3>	



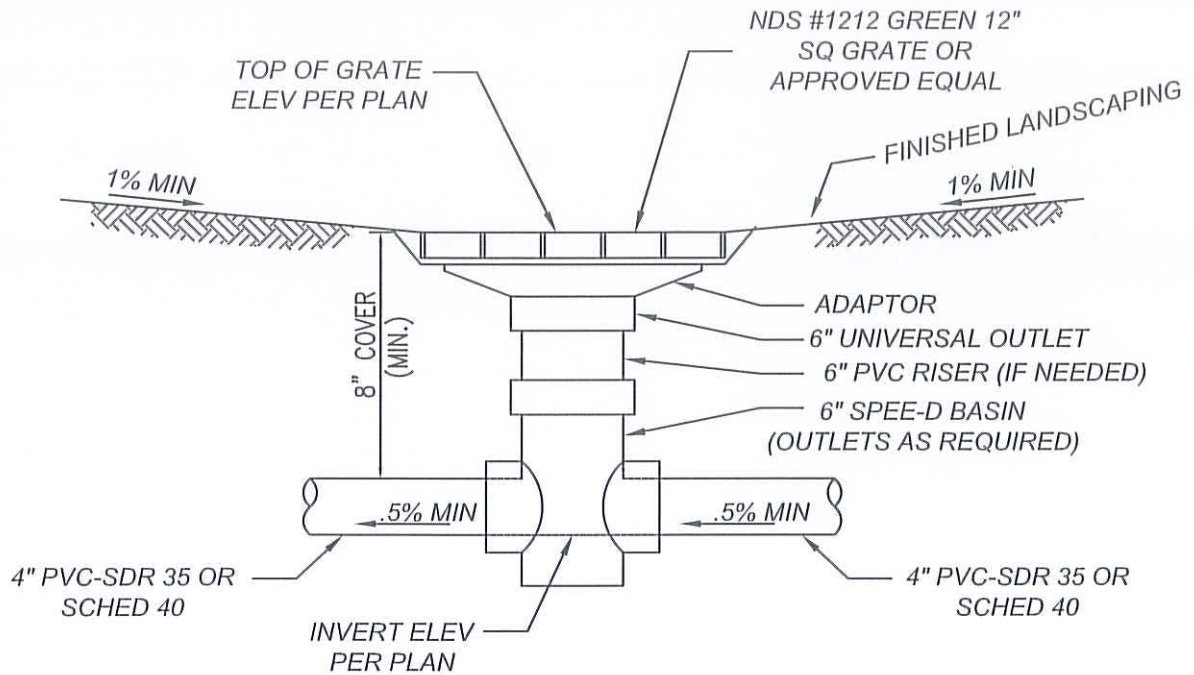

**NOTES:**

1. REFER TO FINISH LANDSCAPING DRAWING
2. DO NOT GLUE RISER TO PIPE (NEED TO BE ABLE TO REMOVE FOR MAINTENANCE PURPOSES).

NOT TO SCALE

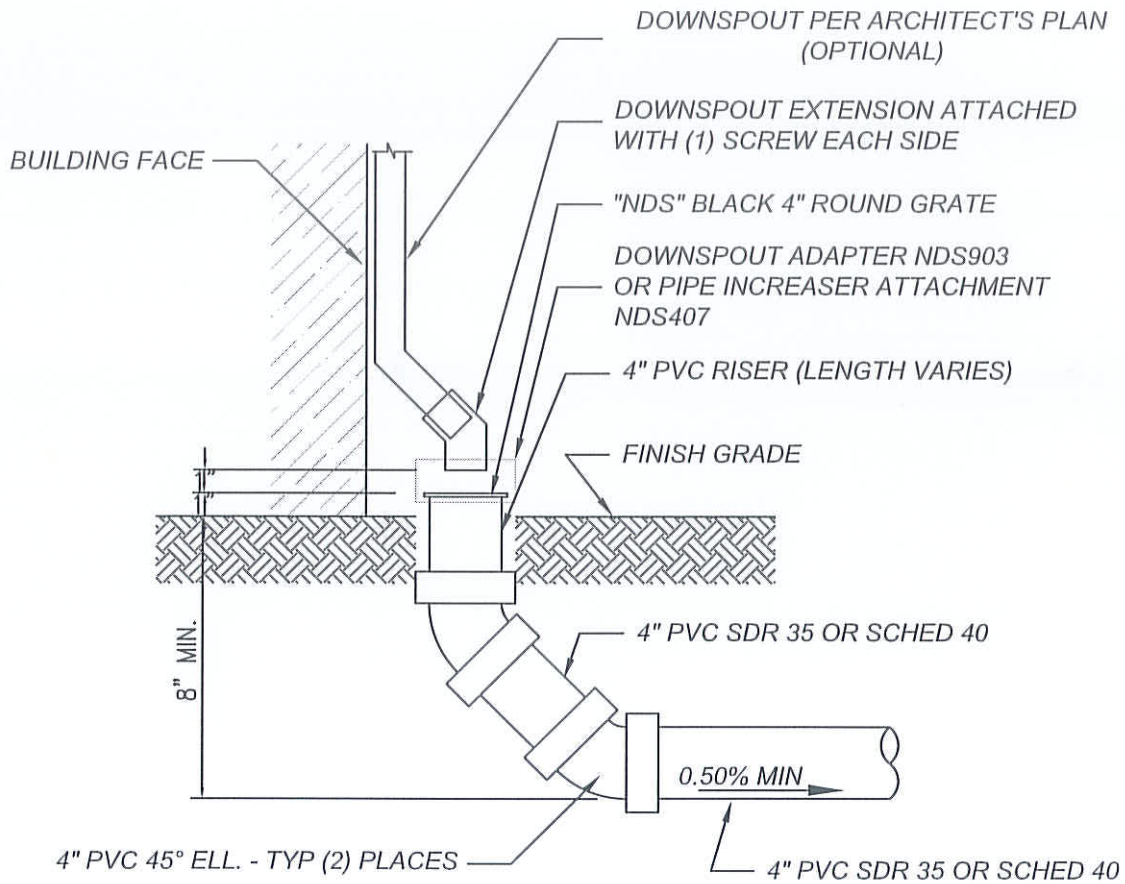

	RECOMMENDED:  DIVISION MANAGER DATE: 1/21/14	<b>CITY OF MORENO VALLEY</b> PUBLIC WORKS DEPARTMENT - LAND DEVELOPMENT DIVISION	STANDARD PLAN <b>MVSI-153B-0</b>
	APPROVED:  PUBLIC WORKS DIRECTOR / CITY ENGINEER DATE: 1/29/14	<b>RESIDENTIAL YARD DRAIN          B1- TYPICAL AREA DRAINS</b>	SHEET 2 OF 3



**NOTES:**

- 1.) ALL DOWNSPOUTS TO CONNECT TO AREA DRAIN SYSTEM.
- 2.) ONLY ALLOWED WHEN DISCHARGE IS PART OF AN APPROVED NPDES / WQMP SYSTEM.

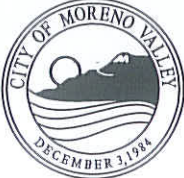
NOT TO SCALE

	RECOMMENDED:  1/21/14 DIVISION MANAGER DATE	<b>CITY OF MORENO VALLEY</b> PUBLIC WORKS DEPARTMENT - LAND DEVELOPMENT DIVISION	
	APPROVED:  1/29/14 PUBLIC WORKS DIRECTOR / DATE CITY ENGINEER	<b>RESIDENTIAL YARD DRAIN          B2 - TYPICAL DRAIN          DOWNSPOUT INLET DETAIL</b>	

## DESIGN POLICY

ANY CHANGES TO THE FOLLOWING REQUIRES PRIOR APPROVAL BY THE CITY ENGINEER:

### STREET DESIGN

- GRADES: 1% TO 9% FOR ARTERIALS, 12 % MAXIMUM FOR LOCALS AND COLLECTORS (SEE ROADWAY DESIGN STANDARD PLAN MVSI-160C); EXCEPT AT INTERSECTIONS, WHERE GRADES SHALL NOT EXCEED 4% ON THROUGH STREETS FOR 100 FEET BEFORE THE CURB RETURNS, AND 2% ON SIDE (CONNECTING) STREETS FOR 50 FEET BEFORE THE CURB RETURNS.
- MINIMUM GRADES: 1% MINIMUM UNLESS OTHERWISE APPROVED BY THE CITY ENGINEER. HOWEVER, ABSOLUTE MINIMUM GRADE SHALL BE NO LESS THAN 0.65%.
- GRADE BREAKS: 0.5% MAXIMUM, EXCESS OF 0.5% REQUIRES 100' MINIMUM VC. 50' MINIMUM BETWEEN GRADE BREAKS. GRADE BREAKS SHALL NOT EXCEED 0.5% TOTAL IN 200'.
- PROFILE MAXIMUM GRADIENT ADJACENT TO CROSS GUTTER: 2.50%.
- CHANGE IN PROFILE GRADES SHOULD NOT EXCEED 6% THROUGH VERTICAL CURVE.
- STREET STRUCTURAL SECTION SHALL BE PER CITY STANDARD OR SOIL ENGINEERS RECOMMENDATION, WHICHEVER IS GREATER.
- NO CROSS GUTTER AT INTERSECTION OF ARTERIAL STREETS WHERE CATCH BASINS CAN BE INSTALLED UPSTREAM.
- THE PAVEMENT CROSS SLOPE/GRADE ALONG THE ALIGNMENT OF ALL PEDESTRIAN CROSSWALKS MUST NOT EXCEED 1.5% OR PER LATEST ADA REQUIREMENTS.
- ALL PAVEMENT REPAIR SURFACE COURSE SHALL BE PG 64-16 ASPHALT RUBBER HOT MIX (ARHM-GG-C) OR AS APPROVED BY THE CITY ENGINEER. SEE CITY STANDARDS No MVSI-132, A THROUGH F.

### STREET CROSS SLOPE

- GRADES: 1.7% MINIMUM, 2% STANDARD (ALL NEW STREETS), 3.5% MAXIMUM.
- WIDENING OR JOINING EXISTING STREET REQUIRES COPY OF WORK SHEET SHOWING PROPOSED AND EXISTING X-SLOPES, ELEVATIONS, ETC., CROSS SECTIONS TO BE TAKEN EVERY 50 FEET.

### STREET ALIGNMENT

- CENTERLINE RADIUS: SEE STANDARD No MVSI-160C.
- STREET INTERSECTIONS AND STREET/DRIVEWAY INTERSECTIONS: 90° ± 5°.
- 0+00: TO BE GOOD, KNOWN POINT, PREFER CENTERLINE INTERSECTION.
- STATIONING: WEST TO EAST AND NORTH TO SOUTH, PREFER LEFT TO RIGHT ON DRAWING.
- 100 FEET TANGENT BETWEEN HORIZONTAL CURVES.

### STORM DRAINS (REFER TO RIVERSIDE COUNTY FLOOD CONTROL DISTRICT DESIGN MANUAL FOR ALL OTHER CRITERIA)

- MATERIAL: RCP, OR AS APPROVED BY THE CITY ENGINEER.
- SIZE: 24" MINIMUM MAINLINE, 24" MINIMUM CATCH BASIN LATERAL.
- SLOPE: 0.003 MINIMUM MAINLINE, 0.005 MIN ALL OTHERS AND SHOW HGL.
- SUBMIT ANY CALCULATIONS USED (CATCH BASIN SIZING, HYDROLOGY, ETC.).
- ALL STORM DRAIN SYSTEMS (AND LATERALS) SHALL BE DESIGNED TO A 100-YEAR STORM EVENT, UNLESS PRIOR APPROVAL BY THE CITY ENGINEER IS GIVEN.
- CATCH BASINS SHALL HAVE A MINIMUM OF 1.0' OF FREEBOARD AT THE CURB OPENING ABOVE THE HGL.

### STREET CAPACITY

- ALL DEPTHS OF WATER ARE NOT TO EXCEED ROW ELEVATION FOR 100YR FLOOD AND DEPTHS OF WATER FOR 10YR FLOOD ARE NOT TO EXCEED TOP OF CURB ELEVATION. HOWEVER, ONE LANE OF TRAFFIC FLOW IN EACH DIRECTION OF TRAVEL MUST REMAIN OPEN ALONG ARTERIAL STREETS AND ABOVE AND 12' TRAVEL PATH ON LOCAL AND COLLECTOR STREETS DURING THE 100 YR FLOOD EVENT. ALL EXCESS FLOWS THAT DO NOT MEET THIS CRITERIA MUST BE CAPTURED IN A STORM DRAIN SYSTEM.



### MONUMENTATION

- ALL MONUMENTS SHALL BE INSTALLED PER STANDARD PLANS MVSI-170-0 SERIES.
- NAIL AND TAG ON TOP OF CURB AT ALL PROPERTY LINE PROLONGATIONS.
- CENTERLINE TIE SHEETS REQUIRED AT COMPLETION OF WORK ( 8 1/2" x 11" MYLAR) TRACTS AND COMMERCIAL PARCEL MAPS AND/OR WHEN NEW INTERSECTION STREETS ARE CREATED.

### CURB RETURN / HEIGHTS

- RADIUS: 25 FEET MINIMUM FOR LOCAL STREETS, 35' FOR INDUSTRIAL AND ABOVE, 50' AT INTERSECTION OF 2 TRUCK ROUTES.
- ELEVATIONS: SHOW BCR, 1/4, 1/2, 3/4, DELTAS, AND ECR.
- DIFFERENCE IN BCR ELEVATION AND ECR ELEVATION SHOULD NOT EXCEED 2 FEET, PREFER 1.5 FOOT, MAXIMUM.
- 6 INCH CURB FACE IN RESIDENTIAL.
- 8 INCH CURB FACE ON INDUSTRIAL COLLECTORS AND ABOVE.
- GUTTER HIKEUP AND ADJACENT ROADWAY PAVEMENT AT CURB RAMP MUST MEET ADA REQUIREMENTS.

NOT TO SCALE

	RECOMMENDED:  10/13/16 DIVISION MANAGER DATE	<h2 style="margin: 0;">CITY OF MORENO VALLEY</h2> <p style="margin: 0;">PUBLIC WORKS DEPARTMENT - LAND DEVELOPMENT DIVISION</p>
	APPROVED:  10/29/16 PUBLIC WORKS DIRECTOR / DATE CITY ENGINEER	<h2 style="margin: 0;">DESIGN POLICY</h2>

**DESIGN POLICY ( continued )**

ANY CHANGES TO THE FOLLOWING REQUIRES PRIOR APPROVAL:

**WATER AND SEWER LINES**

- REFER TO EMWD DESIGN CRITERIA.



**GRADING PLANS**

- CHECK THE GRADING REGULATIONS IN THE CITY MUNICIPAL CODE CAREFULLY.
- GRADING PLAN TO SHOW ALL EXISTING AND PROPOSED ELEVATIONS AND CONTOURS, ADJACENT ELEVATIONS, PROPOSED ELEVATIONS OF HOUSE PADS, LOT CORNERS, SWALES, HIGH AND LOW POINTS.
- ENGINEER SHALL SUBMIT ROUGH GRADING PLANS AND PRECISE GRADING PLANS UNLESS APPROVED OTHERWISE BY THE CITY ENGINEER.
- ALL SLOPES SHALL BE ON LOWER PROPERTY.
- A CORNER LOT WITH A SIDEYARD SLOPE ADJACENT TO A SIDEWALK TO BE 5:1 MAXIMUM SLOPE.
- NO COMMON SWALES PERMITTED. (NOT ON PROPERTY LINE)
- GRADING PLANS AND STREET IMPROVEMENT PLANS SHOULD BE REVIEWED AT THE SAME TIME.
- CALCULATIONS SHALL BE SUBMITTED TO VERIFY YARDAGES. (EARTHWORK)
- TEMPORARY EROSION CONTROL PLANS SHALL BE REQUIRED TO BE SUBMITTED WITH GRADING PLANS. THIS DOES NOT REPLACE A STORM WATER POLLUTION PREVENTION PLAN (SWPPP).
- RETAINING WALLS REQUIRE SEPARATE BUILDING PERMIT. ALL WALLS MUST SHOW TOP OF WALL (TW) AND TOP OF FOOTING (TF) ELEVATIONS AND LENGTHS. DRAINAGE IS **NOT** ALLOWED TO FLOW AGAINST OR OVER THE WALL. A DRAINAGE STRUCTURE IS REQUIRED ADJACENT TO THE TOP OF THE WALL.
- A PRELIMINARY SOILS INVESTIGATION REPORT PREPARED BY A REGISTERED GEOTECHNICAL ENGINEER IS REQUIRED.
- SLOPES SHALL NOT EXCEED 2:1.
- SUBDRAINS ARE REQUIRED WHEN FILLS ARE PLACED OVER NATURAL DRAINAGE COURSES.
- SIDE AND REAR OF BUILDING PAD WILL BE ELEVATED SUCH THAT THE PAD AREA WILL HAVE A SLOPE OF 5% MINIMUM, 20% MAXIMUM, TOWARD AN ACCEPTABLE DRAINAGE OUTLET. GRADED SWALES WILL HAVE A MINIMUM SLOPE OF 2%. THE SWALE CENTERLINE SHALL BE 3' MINIMUM AWAY FROM THE PAD ALONG SIDE YARDS AND 10' MINIMUM ALONG THE REAR. THERE SHALL BE 2' MINIMUM DISTANCE FROM GRADED SWALE CENTERLINE AND PROPERTY LINES. THE FIRST FOOT FROM THE PROPERTY LINE SHALL BE AT 2% SLOPE AWAY FROM THE PROPERTY LINE THEN UP TO A 2:1 SLOPE MAY BE CONSTRUCTED (SEE STD MVS1-154).
- ENGINEERED FILLS SHALL BE COMPACTED TO NOT LESS THAN 90% OF MAXIMUM DENSITY AS DETERMINED BY ASTM TEST D1557.
- ALL CUT SLOPES OVER 5' AND FILL SLOPES OVER 3' SHALL BE PLANTED.
- DRIVEWAYS SHALL NOT EXCEED 12% MAXIMUM SLOPE.
- ALL WALL/FENCES SHALL BE AT THE TOP OF SLOPES.
- DRAINAGE SHALL BE DIRECTED TO AREA DRAINS. NO DEVELOPMENT SHALL DRAIN OVER DRIVEWAYS OR SIDEWALKS.
- COMMERCIAL, OFFICE, AND INDUSTRIAL PARKING LOT DRIVE AISLES, PARKING LOT DRIVES, AND PARKING STALLS SHALL NOT EXCEED 5% SLOPE. AT DISABLED PARKING STALLS, MAXIMUM SLOPE SHALL NOT EXCEED 2% IN ANY DIRECTION. ALONG ADA PATH OF TRAVEL, MAXIMUM LONGITUDINAL SLOPE SHALL NOT EXCEED 5% AND MAXIMUM CROSS SLOPE SHALL NOT EXCEED 2%.

**COST ESTIMATES**

- SUBMIT BREAK DOWN OF COST ON A PER ITEM BASIS. PROVIDE CALCULATIONS WORK SHEETS ALONG WITH LIST OF ASSUMPTION. (SEE CITY COST ESTIMATE SPREAD SHEET ON THE CITY WEB SITE).
- DENSITY FOR ASPHALT CONCRETE AND AGGREGATE BASE: 150 lb/ft<sup>3</sup>.
- SUBMIT EARTHWORK QUANTITIES WITH CALCULATIONS USED.

NOT TO SCALE

	RECOMMENDED:  DIVISION MANAGER	10/13/20 DATE	<b>CITY OF MORENO VALLEY</b> PUBLIC WORKS DEPARTMENT - LAND DEVELOPMENT DIVISION	
	APPROVED:  PUBLIC WORKS DIRECTOR / CITY ENGINEER	10/29/20 DATE	<b>DESIGN POLICY</b>	STANDARD PLAN <b>MVSI-160B-1</b>

# STREET CLASSIFICATION

		RURAL STREET (STD MVSI-107C)	MODIFIED LOCAL (STD MVSI-107B)	GENERAL LOCAL (STD MVSI-107A)	COLLECTOR (STD MVSI-106B), INDUSTRIAL COLLECTOR (STD MVSI-106A)	MINOR ARTERIAL (STD MVSI-105A)	ARTERIAL (STD MVSI-104A)	DIVIDED ARTERIAL (STD MVSI-103A)	MODIFIED DIVIDED MAJOR ARTERIAL (STD MVSI-102A)	DIVIDED MAJOR ARTERIAL (STD MVSI-101A)	EXPRESSWAY (STD MVSI-101A)
R/W (FT)		40	50	56	66 78	88	100	110	120	134	134
CURB TO CURB WIDTH (FT)		28	36	36	44 56	64	76	86	102	110	110
MINIMUM RADII HORIZONTAL (FT)	FLAT (0-4%)	300	300	300	850	1600	2000	-	2000	2000	2000
	ROLLING (4-6%)	300	300	300	550	-	-	-	-	-	-
	MOUNTAINOUS (> 6%)	150	150	150	300	-	-	-	-	-	-
MAXIMUM GRADE (%)	FLAT	4	4	4	4	3	3	-	3	3	3
	ROLLING	9	9	9	8	6	6	7	6	6	6
	MOUNTAINOUS	12	12	12	12	9	9	9	9	-	-
DESIGN SPEED (MPH)	FLAT	30	30	30	45	55	60	-	60	60	60
	ROLLING	30	30	30	35	48	55	45	55	55	55
	MOUNTAINOUS	20	20	25	30	35	48	35	48	-	-
INTERSECTION (C <sub>1</sub> TO C <sub>2</sub> ) INTERVALS (FT)		N/A	200	200	200	(1) 330	(1) 660	(2) 660	(1) 1320	(1) 1320	(1),(2) 5280

- (1) DIRECT RESIDENTIAL ACCESS RESTRICTED.  
 (2) DIRECT ACCESS RESTRICTED.

**NOTES:**

- 1.) MINIMUM GRADE = 1.0 %  
 2.) ROADWAY DESIGN LESS THAN SHOWN REQUIRES APPROVAL OF THE CITY ENGINEER.

NOT TO SCALE

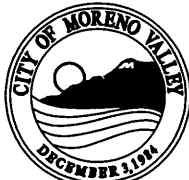
	RECOMMENDED: <i>MDL</i> 12/29/16 DIVISION MANAGER DATE	<b>CITY OF MORENO VALLEY</b> PUBLIC WORKS DEPARTMENT - LAND DEVELOPMENT DIVISION		
	APPROVED: <i>[Signature]</i> 1/20/17 PUBLIC WORKS DIRECTOR / DATE CITY ENGINEER	<b>ROADWAY DESIGN REQUIREMENTS</b>		STANDARD PLAN <b>MVSI-160C-1</b>
				SHEET 3 OF 3



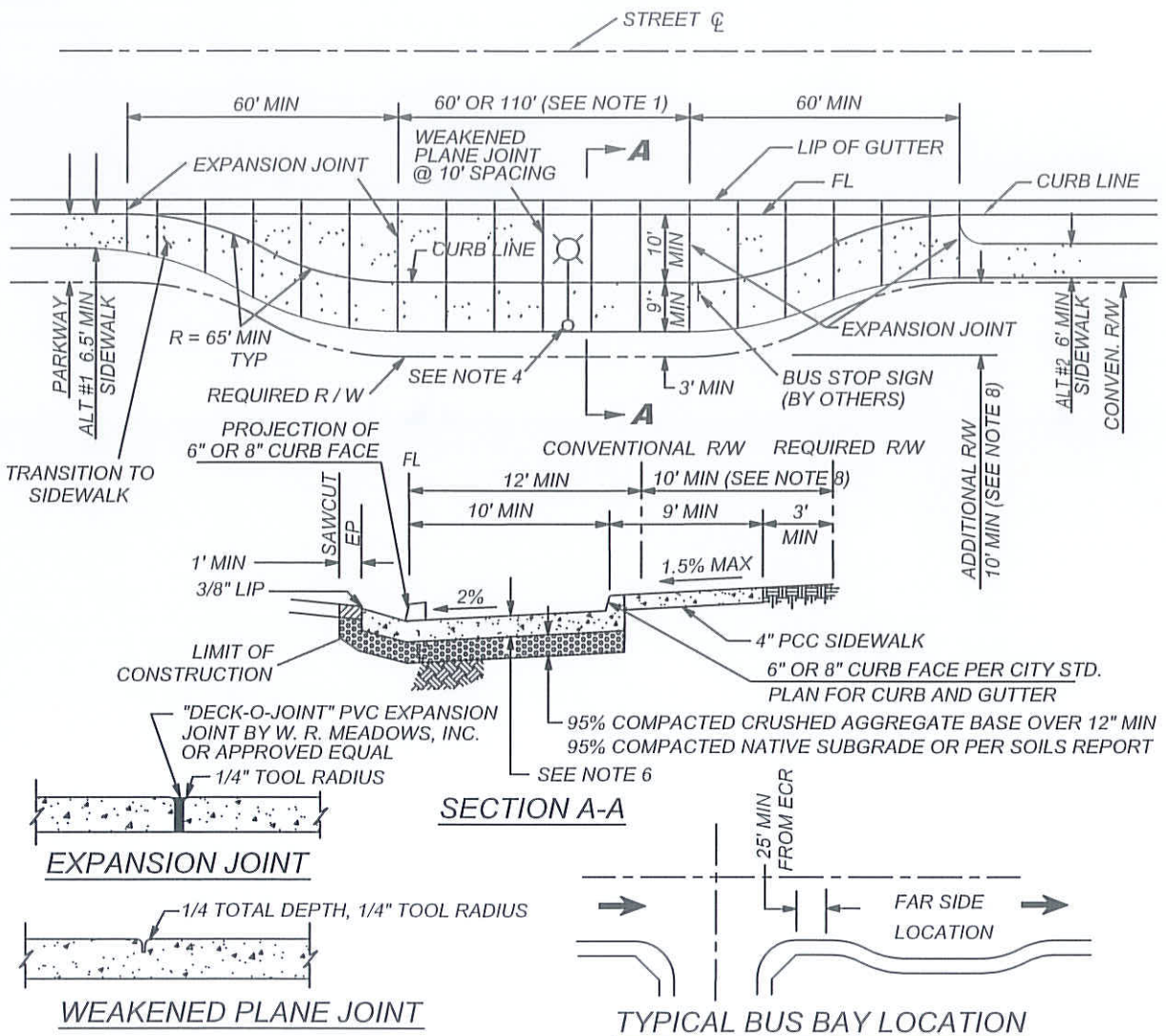



**NOTES:**

1. LENGTH OF STORAGE DETERMINED BY SINGLE OR DOUBLE BUS STOP AS SPECIFIED BY SERVING TRANSIT AGENCY AND APPROVED BY THE CITY ENGINEER.
2. IF BENCH/SHELTER IS PROPOSED, 4 FEET MINIMUM OF SIDEWALK CLEARANCE IS REQUIRED.
3. FAR SIDE BUS BAY LOCATION IS PREFERRED, PER ABOVE DETAIL.
4. ADDITIONAL STREET LIGHTING WITH LONGER MAST ARM MAY BE REQUIRED AS DETERMINED BY THE CITY ENGINEER.
5. CONSTRUCT EXPANSION JOINTS (AT 60' SPACING) AND WEAKENED PLANE JOINTS (AT 10' SPACING) OR AS DIRECTED BY THE CITY ENGINEER.
6. PCC PAVEMENT THICKNESS SHALL BE DETERMINED BY THE ENGINEER. STRUCTURAL SECTION CALCULATIONS ARE REQUIRED. MINIMUM THICKNESS SHALL BE 8" PCC WITH #4 REBARS AT 24" OC IN BOTH DIRECTIONS OVER 6" AB OVER 12" MIN. 95% COMPACTED NATIVE SUBGRADE OR PER SOIL REPORT. CONCRETE SHALL BE CLASS 560-C-3250.
7. CURB SHALL BE POURED MONOLITHIC WITH PCC PAVEMENT.
8. ADDITIONAL R/W AND / OR EASEMENTS MAY BE REQUIRED BY CITY ENGINEER.
9. LOCATION OF BUS TURNOUT SHOULD BE AS APPROVED BY THE TRANSPORTATION DIVISION AND IN CONSULTATION WITH THE APPROPRIATE TRANSIT AGENCY.

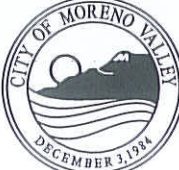
NOT TO SCALE

	RECOMMENDED:  DIVISION MANAGER / DATE 1/21/14	<h2 style="margin: 0;">CITY OF MORENO VALLEY</h2> <p style="margin: 0;">PUBLIC WORKS DEPARTMENT - CAPITAL PROJECTS DIVISION</p>	STANDARD PLAN <h3 style="margin: 0;">MVSI-161-0</h3>
	APPROVED:  PUBLIC WORKS DIRECTOR / DATE 1/29/14	<h2 style="margin: 0;">BUS TURNOUT</h2>	SHEET 1 OF 1

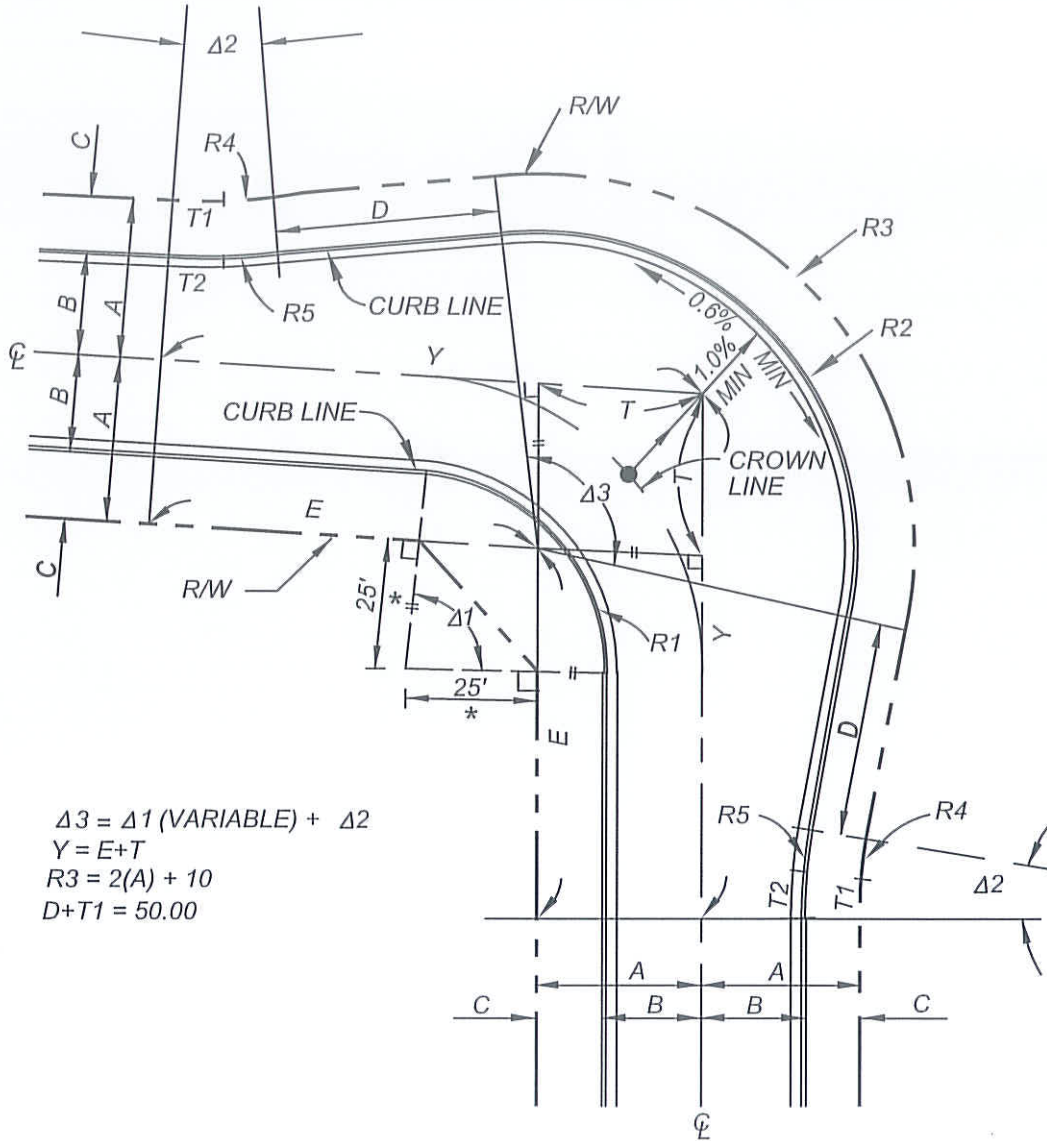

$\Delta 3 = \Delta 1 \text{ (VARIABLE)} + \Delta 2$   
 $Y = E + T$   
 $R3 = 2(A) + 10$   
 $D + T1 = 50.00$

R/W	ROADWAY IMPROVEMENT WIDTH	A	B	C	D	E	R1	R2	R3	$\Delta 2$	R4	T1	R5	T2
50	36	25	18	7	40.91	69.09	34	53	60	10°23'20"	100	9.09	107	9.91
56	36	28	18	10	40.99	70.00	35	56	66	10°17'48"	100	9.01	110	9.91
60	40	30	20	10	41.04	70.60	35	60	70	10°14'12"	100	8.96	110	9.85
66	44	33	22	11	41.12	71.49	36	65	76	10°08'58"	100	8.88	111	9.86
78	56	39	28	11	41.26	73.23	36	77	88	9°58'58"	100	8.73	111	9.69

DISTANCES IN FEET

**NOTES:**

- 1.) THE VALUE FOR "T" & "Y" WILL VARY ACCORDING TO DESIGN.
- 2.) LIMITS OF CROSS SLOPE, CROWN LINE TO OUTSIDE GUTTER: MINIMUM OF 1%.

\* 25' REGARDLESS OF R/W WIDTH.

NOT TO SCALE



RECOMMENDED:  
  
 DIVISION MANAGER / DATE 1/21/14

APPROVED:  
  
 PUBLIC WORKS DIRECTOR / DATE 1/29/14  
 CITY ENGINEER

**CITY OF MORENO VALLEY**  
 PUBLIC WORKS DEPARTMENT - CAPITAL PROJECTS DIVISION

**KNUCKLE**

STANDARD PLAN  
**MVSI-162-0**

SHEET 1 OF 1



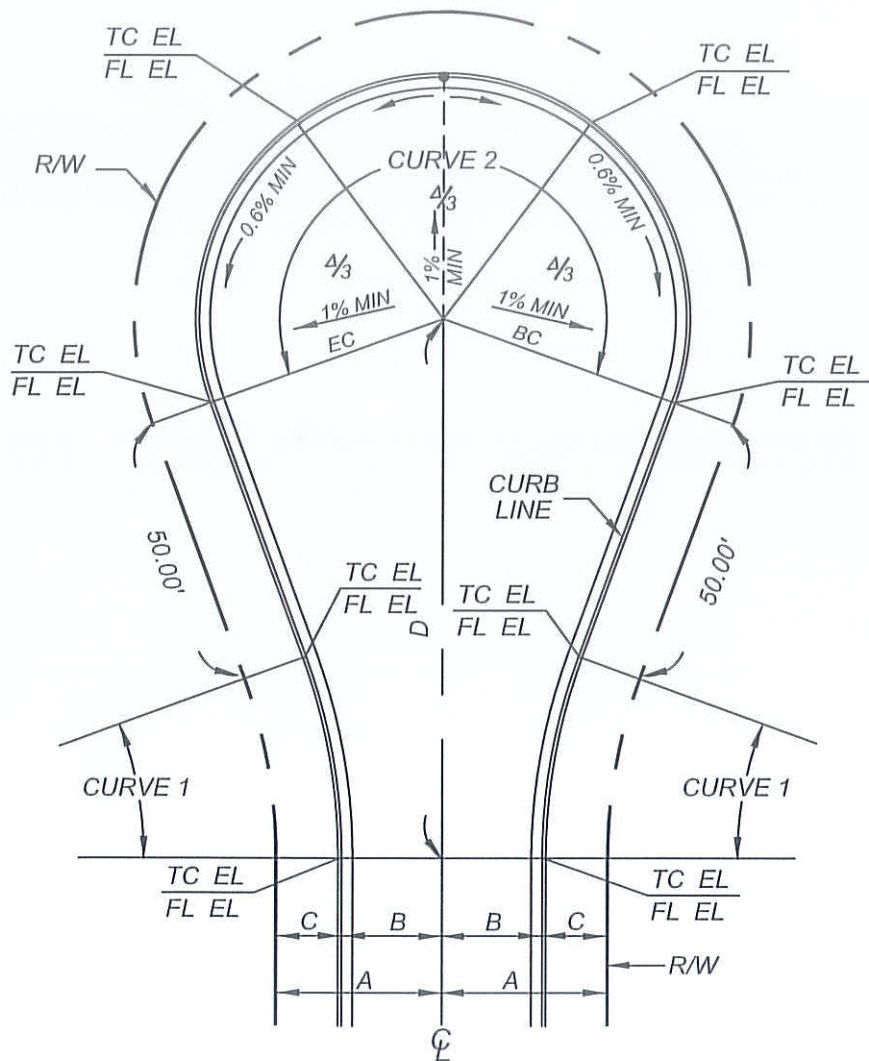

R/W	CURVE 1				Δ	CURVE 2								
	A	B	C	D		CURB		R/W		Δ	CURB		R/W	
						R	L	R	L		R	L	R	L
50'	25'	18'	7'	88.88'	16°23'22"	107'	30.61'	100'	28.60'	212°46'43"	38'	141.12'	45'	167.12'
56'	28'	18'	10'	89.55'	16°18'41"	110'	31.31'	100'	28.47'	212°37'22"	38'	141.02'	48'	178.12'
60'	30'	20'	10'	86.63'	15°00'38"	110'	28.82'	100'	26.20'	210°01'17"	38'	139.29'	48'	175.95'
66'	33'	22'	11'	83.74'	13°38'40"	111'	26.44'	100'	23.82'	207°17'21"	38'	137.48'	49'	177.28'
78'	39'	28'	11'	95.39'	17°12'31"	111'	33.33'	100'	30.03'	214°25'02"	50'	187.11'	61'	226.27'
88'	44'	32'	12'	103.27'	19°15'21"	112'	37.64'	100'	33.61'	218°30'42"	58'	221.20'	70'	266.96'

NOT TO SCALE

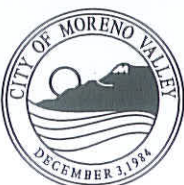

RECOMMENDED:  
*[Signature]* 1/29/14  
 DIVISION MANAGER DATE

APPROVED:  
*[Signature]* 1/29/14  
 PUBLIC WORKS DIRECTOR / DATE  
 CITY ENGINEER

**CITY OF MORENO VALLEY**  
 PUBLIC WORKS DEPARTMENT - LAND DEVELOPMENT DIVISION

**CUL-DE-SAC  
 (SYMMETRICAL)**

STANDARD PLAN  
**MVSI-163A-0**

SHEET 1 OF 2

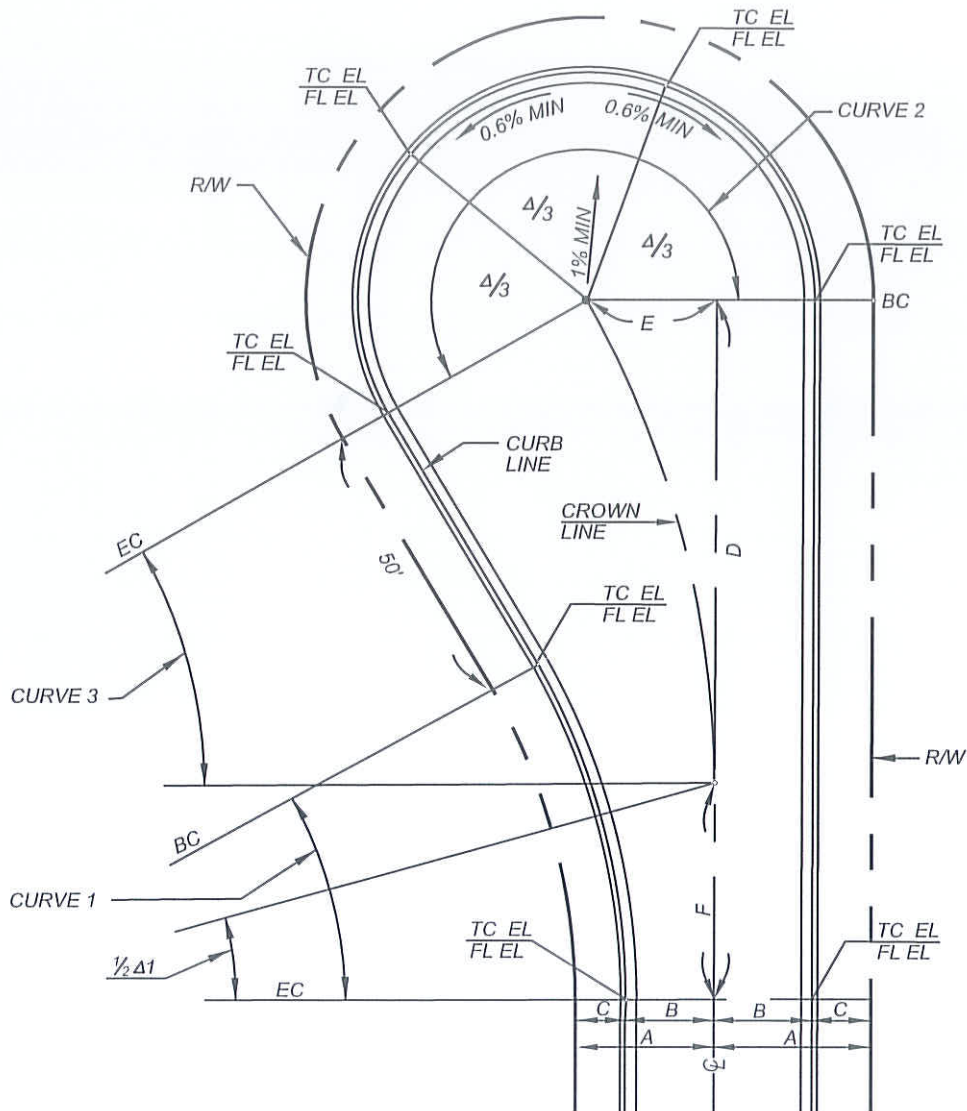

R/W	CURVE 1						CURVE 2				CURVE 3								
	A	B	C	D	E	F	Δ	CURB		R/W		Δ	CROWN LINE						
								R	L	R	L		R	L					
50'	25'	18'	7'	111.80'	20'	30.17'	27°46'18"	107'	51.86'	100'	48.47'	207°46'18"	38'	137.80'	45'	163.18'	27°46'18"	173.63'	84.16'
56'	28'	18'	10'	112.87'	20'	31.44'	27°35'48"	110'	52.98'	100'	48.17'	207°35'48"	38'	137.68'	48'	173.92'	27°35'48"	175.79'	84.67'
60'	30'	20'	10'	108.90'	18'	29.45'	25°31'48"	110'	49.01'	100'	44.56'	205°31'48"	38'	136.31'	48'	172.18'	25°31'48"	184.35'	82.14'
66'	33'	22'	11'	104.94'	16'	27.47'	23°20'19"	111'	45.21'	100'	40.73'	203°20'19"	38'	134.86'	49'	173.90'	23°20'19"	195.54'	79.65'
78'	39'	28'	11'	121.37'	22'	35.69'	28°47'56"	111'	55.79'	100'	50.26'	208°47'56"	50'	182.21'	61'	222.30'	28°47'56"	177.87'	89.40'

NOT TO SCALE

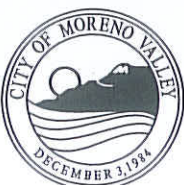

RECOMMENDED:  
  
 DIVISION MANAGER  
 DATE 1/23/14

APPROVED:  
  
 PUBLIC WORKS DIRECTOR / CITY ENGINEER  
 DATE 1/29/14

**CITY OF MORENO VALLEY**  
 PUBLIC WORKS DEPARTMENT - LAND DEVELOPMENT DIVISION

**CUL-DE-SAC  
 (OFFSET)**

STANDARD PLAN  
**MVSI-163B-0**

SHEET 2 OF 2

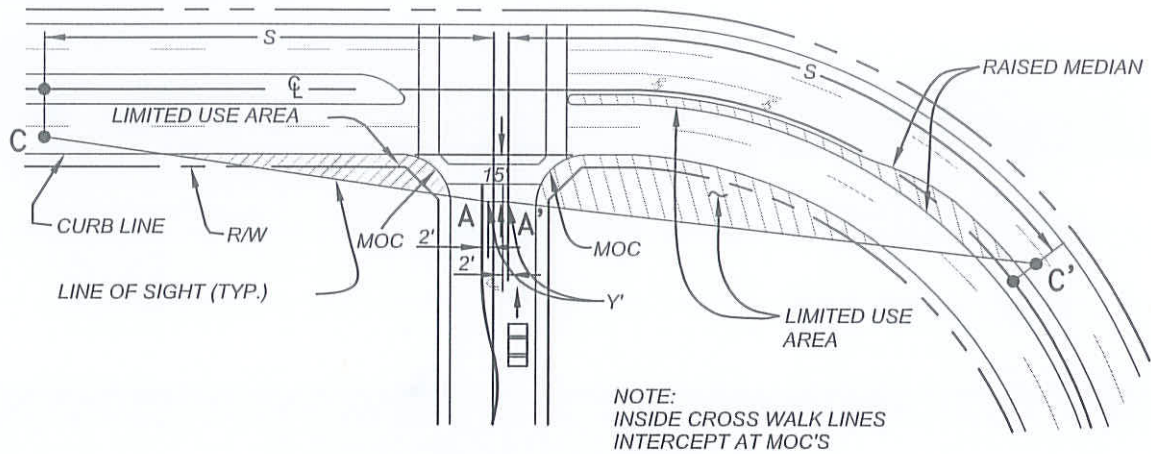

**LEFT AND RIGHT TURN OUT  
AND CROSS TRAFFIC  
SIGHT DISTANCE**

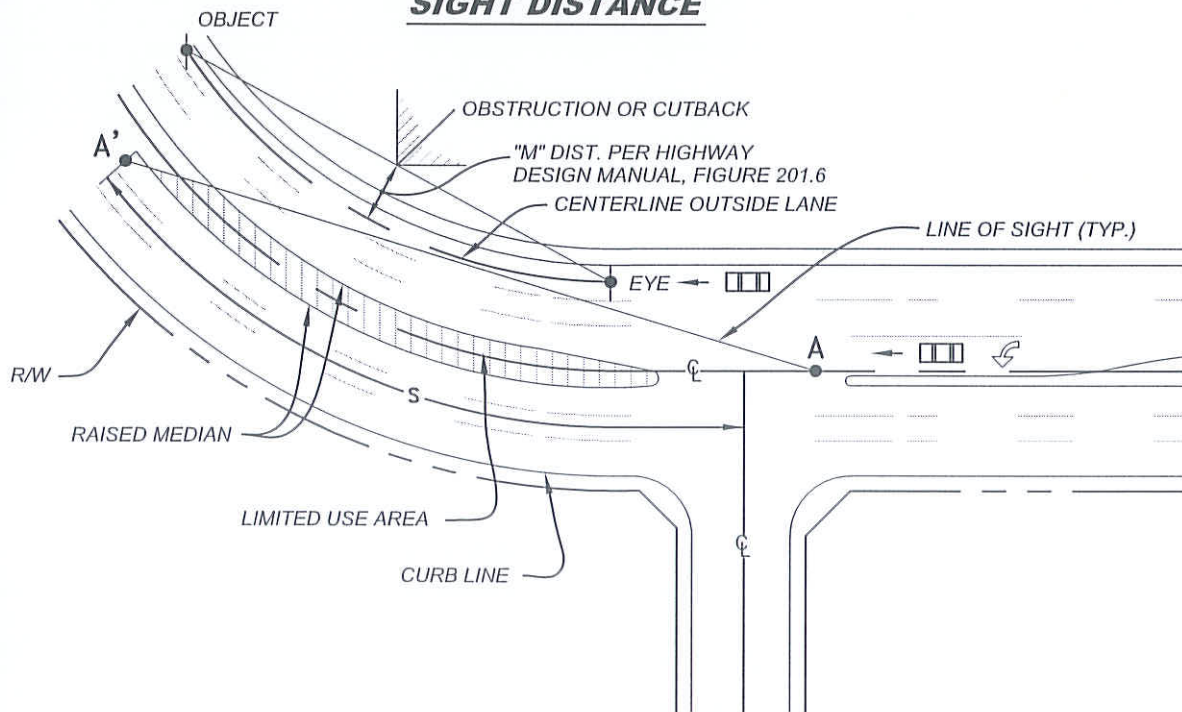

**LEFT TURN IN AND OBSTRUCTION  
SIGHT DISTANCE**

NOT TO SCALE

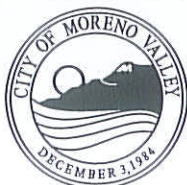

RECOMMENDED:  
*EL*  
 DIVISION MANAGER  
 DATE: *1/22/14*  
 APPROVED:  
*[Signature]*  
 PUBLIC WORKS DIRECTOR / DATE: *1/29/14*  
 CITY ENGINEER

**CITY OF MORENO VALLEY**  
 PUBLIC WORKS DEPARTMENT - TRANSPORTATION ENGINEERING DIVISION

**INTERSECTION  
SIGHT DISTANCE**

STANDARD PLAN  
**MVSI-164A-0**

SHEET 1 OF 3



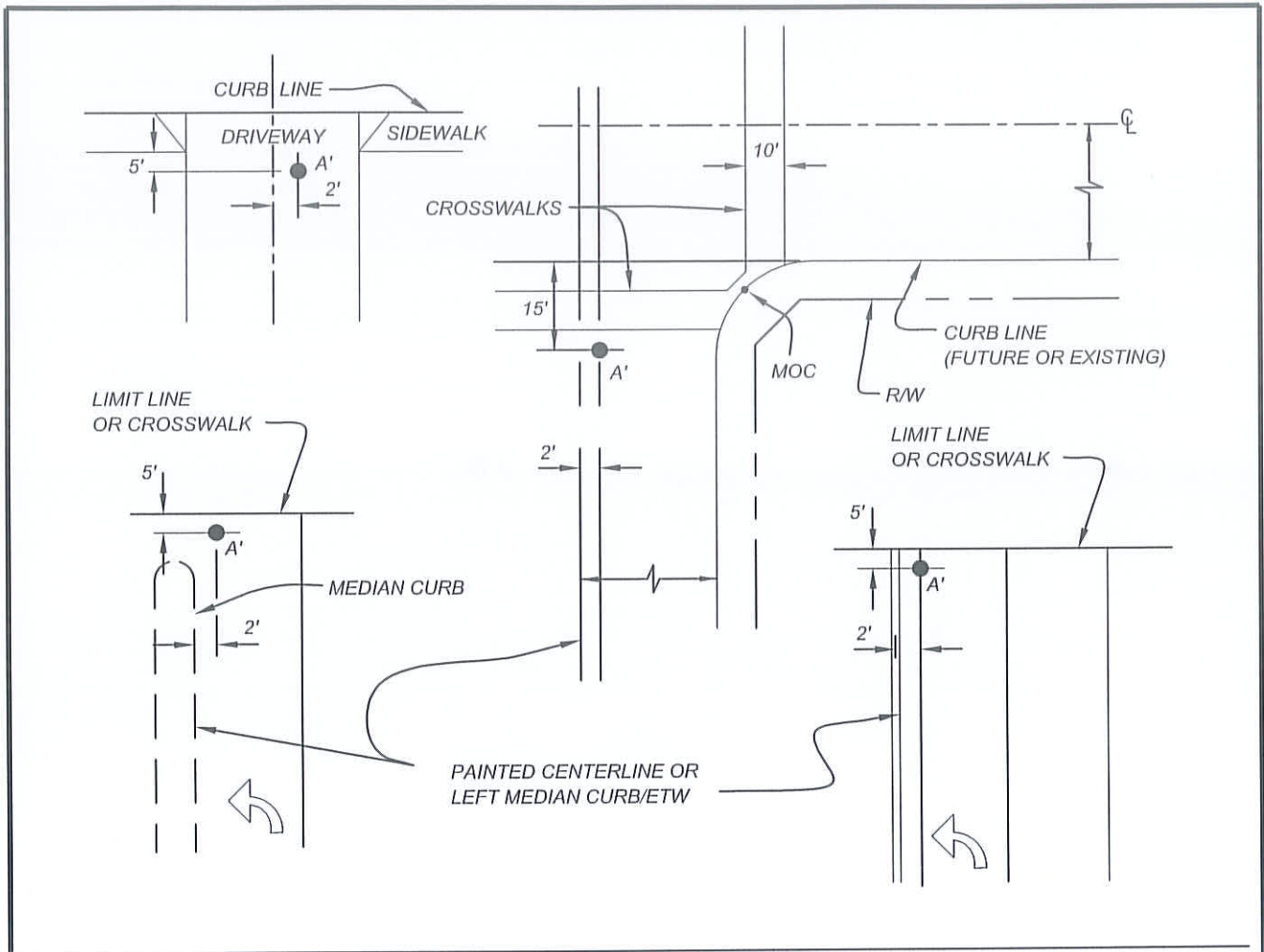

DESIGN OR 85TH PERCENTILE SPEED (MPH)	CORNER SIGHT DISTANCE (FT)
25	275
30	330
35	385
40	440
45	495
50	550
55	605
60	660
65	715

- NOTES:
- = POINT OF MEASUREMENT.
  - FOR INTERSECTION CASES, SEE STD MVSI-164C-0 FOR APPLICATION.
  - REFER TO STD MVSI-164A-0 FOR LINE OF SIGHT APPLICATION TO DISTANCE (S).
  - WHERE VEHICLES ARE BACKING INTO ON COMING TRAFFIC, A' SHALL BE 13' VERSUS 5'.
  - MOC - MIDDLE OF CURB RETURN.
  - ETW - EDGE OF TRAVELED WAY.
- \* - REQUIRED  
 \*\* - RECOMMENDED

TABLE SOURCE: CALTRANS HIGHWAY DESIGN MANUAL  
 TABLE 405.1A

NOT TO SCALE

	RECOMMENDED: <i>EL</i> DIVISION MANAGER DATE: <i>1/22/14</i>	<h2 style="margin: 0;">CITY OF MORENO VALLEY</h2> <p style="margin: 0;">PUBLIC WORKS DEPARTMENT - TRANSPORTATION ENGINEERING DIVISION</p>	STANDARD PLAN <h3 style="margin: 0;">MVSI-164B-0</h3>
	APPROVED: <i>[Signature]</i> PUBLIC WORKS DIRECTOR/ CITY ENGINEER DATE: <i>1/29/14</i>	<h2 style="margin: 0;">INTERSECTION SIGHT DISTANCE</h2>	SHEET 2 OF 3

**NOTES:**

1. THE DISTANCE S REPRESENTS THE INTERSECTION SIGHT DISTANCE MEASURED ALONG THE CENTERLINE OF THE ROAD. THE INTERSECTION SIGHT DISTANCE IS THE DISTANCE REQUIRED TO ALLOW STOPPING DISTANCE FOR THE DRIVER ON THE CROSS ROAD (OR LEFT TURN POCKET) TO CROSS THE MAIN ROADWAY OR TURN LEFT WHILE THE APPROACH VEHICLE TRAVELS AT THE ASSUMED DESIGN SPEED OF THE MAIN ROADWAY.
2. THE DISTANCE S SHOULD BE INCREASED BY 20% FROM THE AMOUNT SHOWN ON THE STOPPING DISTANCE TABLE ON SUSTAINED DOWNGRADES STEEPER THAN 3% AND LONGER THAN ONE MILE.
3. POINTS A AND A' ARE THE LOCATIONS OF A DRIVER'S LINE OF SIGHT (3.5 FOOT EYE HEIGHT) TO ONCOMING VEHICLES (4.25 FOOT OBJECT HEIGHT) LOCATED AT POINTS C AND C' WHILE IN A VEHICLE AT AN INTERSECTION FIFTEEN FEET FROM THE EDGE OF THE TRAVELED WAY.
4. THE DISTANCE Y' IS THE 2 FOOT DISTANCE MEASURED FROM THE LEFT EDGE OF THE TRAVELED WAY TO THE LOCATION OF THE DRIVER.
5. THE LIMITED USE AREA IS DETERMINED BY THE GRAPHICAL METHOD USING THE APPROPRIATE DISTANCES GIVEN IN THE TABLE IN STANDARD MVSI-164B-0. IT SHALL BE USED FOR THE PURPOSE OF PROHIBITING OR CLEARING OBSTRUCTIONS IN ORDER TO MAINTAIN ADEQUATE SIGHT DISTANCE AT INTERSECTIONS.
6. THE LINE OF SIGHT LINE SHALL BE SHOWN AT INTERSECTIONS ON ALL LANDSCAPING PLANS, GRADING PLANS, AND TENTATIVE TRACT PLANS. IN CASES, WHERE AN INTERSECTION IS LOCATED ON A VERTICAL CURVE, A PROFILE OF THE LINE OF SIGHT MAY BE REQUIRED. THE LANDSCAPE PLAN SUBMITTED SHALL SHOW THE NAME, LOCATION AND MATURE DIMENSIONS, PLOTTED TO SCALE OF ALL THE PROPOSED TREES WITHIN THE LIMITED USE AREA.
7. OBSTRUCTIONS SUCH AS BUS SHELTERS, WALLS OR LANDSCAPING WITHIN THE LIMITED USE AREA WHICH COULD RESTRICT THE LINE OF SIGHT SHALL NOT BE PERMITTED. DRIVEWAYS ARE NOT PERMITTED WITHIN "T" INTERSECTION AREA DUE TO SIGHT DISTANCE RESTRICTION BY ENTERING VEHICLES.
  - a. PLANTS AND SHRUBS WITHIN THE LIMITED USE ARE SHALL BE OF THE TYPE THAT WILL GROW NO HIGHER THAN 30 INCHES ABOVE THE TOP OF CURB AND SHALL BE MAINTAINED AT A HEIGHT WHICH WILL ASSURE THAT THE 30 INCH MAXIMUM HEIGHT IS NOT EXCEEDED BETWEEN MAINTENANCE INTERVALS. MAINTENANCE AT A LOWER HEIGHT MAY BE REQUIRED ON CREST VERTICAL CURVES PER NOTE 6 ABOVE.
  - b. A PROFILE DETAIL OF THE LINE OF SIGHT MAY BE REQUIRED TO VERIFY 12" MINIMUM VERTICAL CLEARANCE ABOVE VARIABLE HEIGHT OBSTRUCTIONS SUCH AS SLOPE LANDSCAPING, PLANTS, SHRUBS AND PERIMETER WALLS.
  - c. THE TOE OF SLOPE MAY NOT ENCROACH INTO THE LIMITED USE AREA UNLESS THE REQUIREMENTS OF (b) ABOVE ARE SATISFIED.
  - d. IN LIEU OF PROVIDING A PROFILE OF THE LINE OF SIGHT PER NOTE 7.b. ABOVE, THE TOE OF SLOPE SHALL NOT ENCROACH INTO THE LIMITED USE AREA, AND THE LIMITED USE AREA SHALL SLOPE 2% MAXIMUM BETWEEN THE LINE OF SIGHT AND THE BACK OF SIDEWALK.
8. NO PARKING IS ALLOWED WITHIN THE LIMITED USE AREA.
9. TREES ARE GENERALLY NOT PERMITTED WITHIN ANY PORTION OF THE LIMITED USE AREA. EXCEPTIONS ARE ALLOWED WHEN THE SPECIES HAS A MATURE TRUNK DIAMETER OF 6 INCHES OR LESS.
10. MEDIAN AREAS LESS THAN FIVE (5) FEET IN WIDTH SHALL NOT BE LANDSCAPED.
11. INTERSECTION SIGHT DISTANCE AT RIGHT ANGLE INTERSECTIONS IS MEASURED FROM THE IDENTIFIED MEASUREMENT POINT A', IN ACCORDANCE WITH THE DIAGRAMS ON STD MVSI-164B-0.

NOT TO SCALE

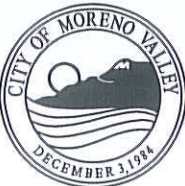
	RECOMMENDED: <div style="display: flex; justify-content: space-between; align-items: center;"> <span style="font-size: 1.2em; color: blue;">EL</span> <span style="font-size: 1.2em; color: blue;">1/22/14</span> </div> <small>DIVISION MANAGER      DATE</small>	<h2 style="margin: 0;">CITY OF MORENO VALLEY</h2> <p style="margin: 0;">PUBLIC WORKS DEPARTMENT - TRANSPORTATION ENGINEERING DIVISION</p>	<small>STANDARD PLAN</small> <h3 style="margin: 0;">MVSI-164C-0</h3>
	APPROVED: <div style="display: flex; justify-content: space-between; align-items: center;"> <span style="font-size: 1.5em; color: blue;">[Signature]</span> <span style="font-size: 1.2em; color: blue;">1/29/14</span> </div> <small>PUBLIC WORKS DIRECTOR / CITY ENGINEER      DATE</small>	<h3 style="margin: 0;">INTERSECTION SIGHT DISTANCE</h3>	<small>SHEET 3 OF 3</small>

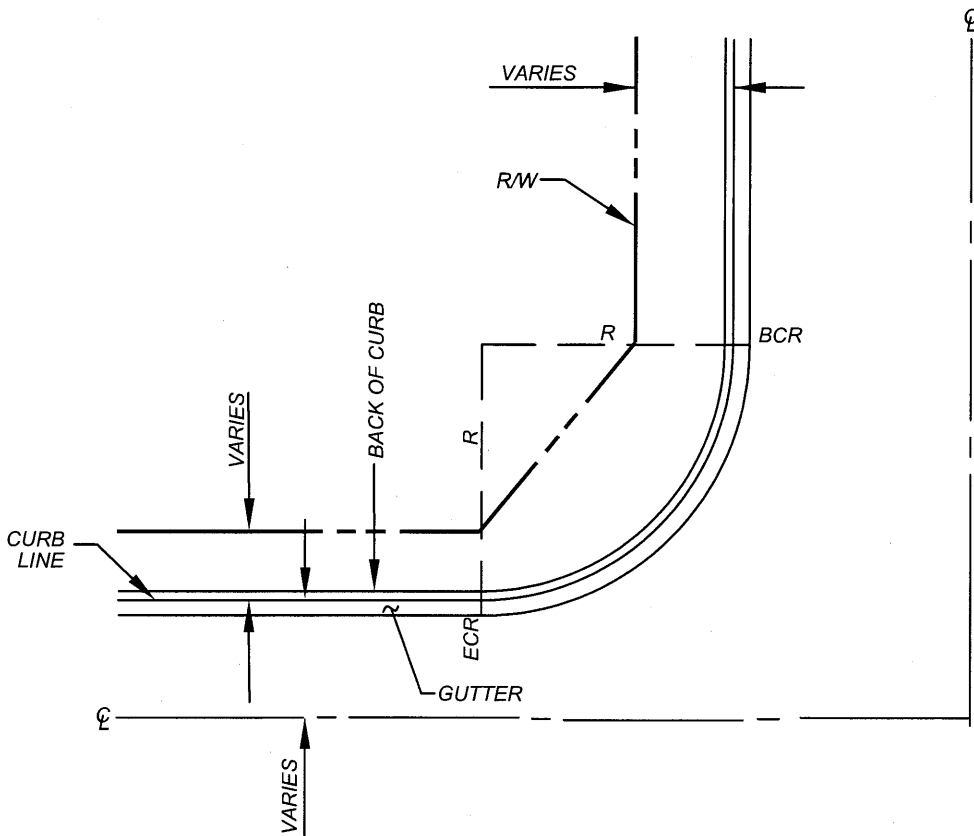

**NOTES:**

- 1.)  $R = 25'$  IF INTERSECTING STREETS HAVE A WIDTH LESS THAN 64' CURB TO CURB.
- 2.)  $R = 35'$  IF EITHER INTERSECTING STREET HAS A WIDTH EQUAL TO OR GREATER THAN 64' CURB TO CURB, EXCEPT IN CASES WHERE SPECIAL DESIGN EXISTS.
- 3.) TYPICALLY,  $R=50'$  AT THE INTERSECTION OF 2 TRUCK ROUTES OR STREETS THAT PRIMARILY SERVE INDUSTRIAL USES. CORNER CUT-BACK AREA MAY BE REDUCED AS APPROVED BY THE CITY ENGINEER. CURB RETURN RADII MAY BE REDUCED IF ADEQUATE TRUCK TURNING RADII CAN BE ESTABLISHED, AS APPROVED BY THE CITY ENGINEER.

NOT TO SCALE



RECOMMENDED:  
**MDL** 12/29/16  
 DIVISION MANAGER DATE

APPROVED:  
 1/20/17  
 PUBLIC WORKS DIRECTOR / DATE  
 CITY ENGINEER

**CITY OF MORENO VALLEY**  
 PUBLIC WORKS DEPARTMENT - LAND DEVELOPMENT DIVISION

**PROPERTY LINE  
 CORNER CUT-BACK  
 CURB RETURN RADIUS**

STANDARD PLAN  
**MVSI-165-0**

SHEET 1 OF 1



**STANDARD GENERAL NOTES (LAND DEVELOPMENT DIVISION):**  
**(APPLICABLE FOR DEVELOPER RELATED PROJECTS)**



1. **HOURS OF OPERATION:** 7:00 AM - 6:00 PM (MONDAY - FRIDAY); WEEKENDS BY PRIOR APPROVAL ONLY (8:00 AM - 4:00 PM), EXCLUDING HOLIDAYS. HOURS MAY BE SHORTENED BY THE CITY ENGINEER PER MUNICIPAL CODE 8.21.050(O).
2. NO WORK SHALL COMMENCE AND NO INSPECTIONS SHALL BE SCHEDULED UNTIL A PERMIT HAS BEEN ISSUED.
3. INSPECTION REQUESTS SHALL BE SUBMITTED TO LDINSPECTIONS@MOVAL.ORG AT LEAST 48 HOURS IN ADVANCE. ANY NIGHT AND/OR WEEKEND INSPECTION REQUESTS REQUIRE MINIMUM 72 HOURS ADVANCED NOTICE IN ORDER TO OBTAIN PLANNING DIVISION APPROVAL.
4. ALL WORK SHALL COMPLY WITH CURRENT CITY STANDARDS, APPLICABLE SECTIONS OF THE MUNICIPAL CODE AND/OR RESOLUTIONS ADOPTED BY THE CITY COUNCIL, AND STANDARD SPECIFICATIONS FOR PUBLIC WORKS CONSTRUCTION EXCEPT AS OTHERWISE NOTED ON THE APPROVED PLANS OR AS APPROVED BY THE CITY ENGINEER.
5. ANY ALTERATION FROM THE APPROVED PLANS, EXCEPT MINOR ADJUSTMENTS IN THE FIELD TO MEET EXISTING CONDITIONS, SHALL BE SUBMITTED FOR REVIEW AND APPROVED BY THE CITY ENGINEER PRIOR TO CONSTRUCTION.
6. AN "AS-BUILT" PLAN SHALL BE SUBMITTED BY THE ENGINEER OF RECORD AT THE COMPLETION OF WORK AND APPROVED BY THE CITY ENGINEER PRIOR TO OCCUPANCY RELEASE.
7. ADJACENT STREETS SHALL BE CLEANED DAILY OF ALL DIRT AND/OR DEBRIS.
8. DUST SHALL BE CONTROLLED BY WATERING OR AS APPROVED BY THE CITY ENGINEER.
9. SURVEY MONUMENTS SHALL BE PROTECTED IN PLACE.
10. CITY APPROVAL OF THESE PLANS SHALL NOT RELIEVE THE CONTRACTOR AND/OR DEVELOPER OF THEIR RESPONSIBILITY TO CORRECT ANY ERRORS AND/OR OMISSIONS DISCOVERED DURING CONSTRUCTION.
11. CITY INSPECTION OF THE WORK SHALL NOT RELIEVE THE CONTRACTOR AND/OR THE DEVELOPER OF THEIR RESPONSIBILITY TO PERFORM THE WORK IN COMPLIANCE WITH THE APPROVED PLANS.
12. CONCRETE GUTTERS, ALLEY APPROACHES, DRIVEWAYS AND OTHER CONCRETE ITEMS SUBJECT TO VEHICULAR TRAFFIC SHALL BE BARRICADED WITH NO VEHICULAR TRAFFIC PERMITTED FOR A PERIOD NO LESS THAN SEVEN (7) DAYS FOLLOWING THE PLACEMENT OF SAID CONCRETE ITEM(S). WHEN THE GENERAL PROVISIONS CALL FOR THE USE OF SAID CONCRETE ITEM(S) FOR VEHICULAR TRAFFIC EARLIER THAN THE SEVENTH DAY FOR CONVENIENCE OF OPERATION OR WHEN THE CONTRACTOR SO DESIRES, CONCRETE CONTAINING EIGHT SACKS OF CEMENT PER CUBIC YARD SHALL BE USED UNDER THE DIRECTION OF THE CITY ENGINEER TO ALLOW TRAFFIC AFTER 72 HOURS OF PLACEMENT OF CONCRETE.
13. CONTRACTOR SHALL BE RESPONSIBLE TO REPAIR OR REPLACE ANY DAMAGED OR ALTERED PUBLIC IMPROVEMENTS AS REQUIRED BY THE CITY ENGINEER.
14. CONTRACTOR SHALL BE RESPONSIBLE TO CONTACT THE APPLICABLE AGENCY OR COMPANY TO VERIFY THE LOCATION OF ANY IRRIGATION AND/OR UTILITY LINES, SHOWN OR NOT SHOWN ON THE APPROVED PLANS PRIOR TO EXCAVATING. CONTRACTOR SHALL BE RESPONSIBLE FOR ANY DAMAGE TO ANY IRRIGATION AND/OR UTILITY STRUCTURE CAUSED BY THEIR OPERATIONS.
15. CONTRACTOR SHALL MAKE PROVISIONS FOR CONTRIBUTORY DRAINAGE AT ALL TIMES.
16. **DECLARATION OF ENGINEER OF RECORD**

BY SIGNING THESE PLANS, I HEREBY DECLARE THAT THE DESIGN OF THE IMPROVEMENTS AS SHOWN ON THESE PLANS COMPLIES WITH PROFESSIONAL ENGINEERING STANDARDS AND PRACTICES, AND THAT I ASSUME FULL RESPONSIBILITY FOR ASSURING THE ACCURACY AND ACCEPTABILITY OF THE DESIGN OF THESE PLANS. AS THE ENGINEER IN RESPONSIBLE CHARGE OF DESIGN OF THESE IMPROVEMENTS, I ASSUME FULL RESPONSIBLE CHARGE FOR SUCH DESIGN. I UNDERSTAND AND ACKNOWLEDGE THAT THE REVIEW OF THESE PLANS BY THE CITY OF MORENO VALLEY IS FOR THE LIMITED PURPOSE OF ENSURING THAT THE PLANS COMPLY WITH CITY PROCEDURES, STANDARDS, APPLICABLE POLICIES AND ORDINANCES. THE REVIEW IS NOT A DETERMINATION OF THE TECHNICAL ADEQUACY OF THE DESIGN OF THE IMPROVEMENTS. SUCH REVIEW DOES NOT, THEREFORE, RELIEVE ME OF MY RESPONSIBILITY FOR THE DESIGN AND IN THE EVENT OF DISCREPANCIES ARISING DURING CONSTRUCTION; I SHALL BE RESPONSIBLE FOR DETERMINING AN ACCEPTABLE SOLUTION AND REVISE THE PLANS FOR CITY ENGINEER APPROVAL.

AS THE ENGINEER OF RECORD (EOR), I AGREE TO INDEMNIFY AND HOLD HARMLESS THE CITY OF MORENO VALLEY, THE MORENO VALLEY HOUSING AUTHORITY, AND THE MORENO VALLEY COMMUNITY SERVICES DISTRICT (CSD), ITS OFFICERS, OFFICIALS, EMPLOYEES, AGENTS AND VOLUNTEERS FROM ANY AND ALL LIABILITY OF CLAIMS, DAMAGES, OR INJURIES TO ANY PERSON OR PROPERTY, WHICH MIGHT ARISE FROM THE NEGLIGENT ACTS, ERRORS, OR OMISSIONS OF THE ENGINEER OF RECORD. I HAVE READ AND INFORMED THE DEVELOPER THAT APPROVAL OF THESE PLANS DOES NOT RELIEVE THEM FROM THE REQUIREMENTS OF THE CONDITIONS OF APPROVAL (ATTACHED HEREIN OR IN OTHER APPROVED PLANS).

I ALSO HEREBY DECLARE THAT I HAVE COMPARED THESE PLANS WITH ALL APPLICABLE ADA TITLE II AND TITLE 24 REQUIREMENTS FOR THIS PROJECT AND THESE PLANS ARE IN FULL COMPLIANCE.

NOT TO SCALE

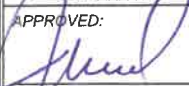
	RECOMMENDED:  DIVISION MANAGER DATE: 1-28-22	<b>CITY OF MORENO VALLEY</b> PUBLIC WORKS DEPARTMENT - LAND DEVELOPMENT DIVISION	STANDARD PLAN <b>MVSI-166A-1</b>
	APPROVED:  PUBLIC WORKS DIRECTOR / CITY ENGINEER DATE: 2/4/22		
			SHEET 1 OF 4

**STANDARD STREET IMPROVEMENT NOTES (LAND DEVELOPMENT DIVISION):**

1. CONTRACTOR SHALL BE RESPONSIBLE FOR THE CLEARING OF THE PROPOSED WORK AREA AND RELOCATION COSTS OF ALL EXISTING UTILITIES.
2. DEVELOPER/OWNER SHALL BE RESPONSIBLE TO NOTIFY THEIR ENGINEER OF RECORD TO INSTALL STREET CENTERLINE MONUMENTS AS REQUIRED BY CITY ORDINANCE FOR NEW DEVELOPMENT AND/OR REPLACE ANY DISTURBED AND/OR COVERED EXISTING MONUMENTS.
3. STREET STRUCTURAL SECTION SHALL BE THE MINIMUM REQUIRED PER THE CITY STANDARD CROSS SECTION OF EACH STREET CLASSIFICATION SUBJECT TO R-VALUE TESTING AND TRAFFIC INDEX. CLASS II CRUSHED AGGREGATE BASE (CAB) PLACED WITHIN THE PUBLIC RIGHT-OF-WAY SHALL BE NATURAL CAB (CLASS II PER CALTRANS STANDARDS FOR SIEVE ANALYSIS) OR AS APPROVED BY THE CITY ENGINEER.
4. ALL STREET STRUCTURAL SECTIONS ARE TENTATIVE. ADDITIONAL SOIL TESTING SHALL BE TAKEN AFTER ROUGH GRADING TO DETERMINE THE EXACT STREET STRUCTURAL SECTION REQUIREMENTS.
5. ALL UNDERGROUND FACILITIES AND/OR STRUCTURES SHALL BE IN PLACE PRIOR TO PAVING THE STREET SECTION INCLUDING DRY AND/OR WET UTILITIES. CITY MAINTAINED STORM DRAINS SHALL BE VIDEO RECORDED AND SUBMITTED TO THE LAND DEVELOPMENT DIVISION.
6. RUBBERIZED EMULSION-AGGREGATE SLURRY (REAS), AS DEFINED IN SECTION 203-5 OF STANDARD SPECIFICATIONS FOR PUBLIC WORKS CONSTRUCTION, SHALL BE APPLIED AT THE CONCLUSION OF THE ONE-YEAR WARRANTY PERIOD, AS DETERMINED BY THE CITY ENGINEER FOLLOWING INSPECTION OF PAVEMENT CONDITIONS. TYPE I SLURRY SHALL APPLY TO THE LOCAL STREET CLASSIFICATION AND TYPE II SLURRY SHALL APPLY TO THE COLLECTOR AND GREATER STREET CLASSIFICATIONS. ALL EXISTING STRIPING, PAVEMENT MARKINGS, AND MARKERS SHALL BE REMOVED (SANDBLASTED) PRIOR TO SLURRY APPLICATION AND RE-ESTABLISHED TO MATCH EXISTING (PRE-SLURRY APPLICATION) AND PER CURRENT CITY STANDARDS.
7. NO PUBLICLY TRAVELED STREET SHALL BE CLOSED TO TRAFFIC WITHOUT PRIOR APPROVAL.
8. STREET STRUCTURAL SECTION DETERMINED TO BE UNSUITABLE FOR OVERLAY DUE TO CRACKING, SUBSIDENCE, IRREGULAR SURFACE, AGE, MATERIAL COMPOSITION, OR WATER DAMAGE SHALL BE REMOVED AND REPLACED AS DIRECTED BY THE CITY ENGINEER.
9. UTILITY TRENCH BACKFILL SHALL BE PER CURRENT CITY STANDARD MVS-132 SERIES.
10. ALL WATER VALVES AND/OR SEWER MANHOLES SHALL BE RAISED TO GRADE IN ACCORDANCE WITH LOCAL WATER PURVEYOR STANDARDS.
11. NO TRENCHES SHALL BE LEFT OPEN OVERNIGHT UNLESS APPROVED BY THE CITY ENGINEER.
12. IF ANY UTILITIES AND/OR FACILITIES CONFLICT WITH PROPOSED IMPROVEMENTS, WORK SHALL STOP AND THE ENGINEER OF RECORD SHALL BE NOTIFIED IMMEDIATELY.
13. AN APPROVED WEED KILLER SHALL BE APPLIED TO THE PREPARED BASE PRIOR TO ASPHALT PAVING.

NOT TO SCALE

	RECOMMENDED: <i>cmd</i> DIVISION MANAGER	1-28-22 DATE	<h2 style="margin: 0;">CITY OF MORENO VALLEY</h2> <p style="margin: 0;">PUBLIC WORKS DEPARTMENT - LAND DEVELOPMENT DIVISION</p>
	APPROVED:  PUBLIC WORKS DIRECTOR / CITY ENGINEER	2/4/22 DATE	<h3 style="margin: 0;">STANDARD STREET IMPROVEMENT NOTES</h3> <p style="margin: 0;"><b>(FOR LAND DEVELOPMENT DIVISION)</b></p>



**STANDARD GRADING NOTES (LAND DEVELOPMENT DIVISION):**  
 (APPLICABLE FOR BORROW SITE, MASS, ROUGH, OR STOCKPILE PLANS)

1. ALL IMPROVEMENTS AS SHOWN ON THIS PLAN WERE PREPARED UNDER THE SUPERVISION OF THE ENGINEER OF RECORD AND IT CONFORMS TO THE LATEST EDITION OF THE CALIFORNIA BUILDING CODE (CBC) AS MODIFIED BY CITY OF MORENO VALLEY ORDINANCE, AND THE INTERIM GUIDELINES.
2. ALL GRADING SHALL BE COMPLETED UNDER THE SUPERVISION OF A REGISTERED SOILS ENGINEER OF RECORD IN CONFORMANCE WITH THE PRELIMINARY GEOTECHNICAL (SOILS) INVESTIGATION BY \_\_\_\_\_ DATED \_\_\_\_\_.
3. THE SOILS COMPACTION REPORT SHALL REFLECT THAT THE COMPACTION HAS BEEN OBTAINED FOR THE BUILDING PAD AND SITE, INCLUDING SLOPES.
4. THE ENGINEER OF RECORD SHALL CERTIFY THAT THE ROUGH GRADING SOIL COMPACTION HAS BEEN COMPLETED PER NOTE 1 AND 2 ABOVE, AND THAT THE SITE CONFORMS TO THE APPROVED PLAN AS TO LINE AND GRADE PRIOR TO THE RELEASE OF THE BUILDING PERMIT.
5. A CERTIFICATE SHALL BE PROVIDED CERTIFYING THAT ALL IMPORTED SOIL IS FREE FROM CONTAMINANTS PRIOR TO UNLOADING.
6. THE SOILS ENGINEER OF RECORD SHALL INSPECT AND ENSURE COMPLIANCE WITH NOTE 2 ABOVE.
7. THE SOILS ENGINEER OF RECORD SHALL TEST AND CERTIFY ALL TRENCH BACKFILLS TO NO LESS THAN 90% MAXIMUM DENSITY AS DETERMINED BY SOIL COMPACTION TEST ASTM-D1557.
8. THE TOP 3 FEET OF SUBGRADE BELOW THE STREET PAVEMENT STRUCTURAL SECTION SHALL BE COMPACTED TO 95% RELATIVE COMPACTION.
9. FILL PLACED OVER EXISTING SLOPING TERRAIN SHALL BE SUPPORTED ON HORIZONTAL BENCH CUT INTO COMPETENT MATERIAL.
10. A SEPARATE BUILDING PERMIT SHALL BE REQUIRED FOR ALL ONSITE SEWER/WATER INSTALLATIONS, WALLS, AND/OR FENCES.

NOT TO SCALE

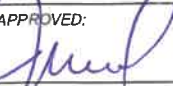
	RECOMMENDED: <div style="display: flex; justify-content: space-between;"> <div style="text-align: center;">             DIVISION MANAGER         </div> <div style="text-align: center;">           1-28-22            DATE         </div> </div>	<h2 style="margin: 0;">CITY OF MORENO VALLEY</h2> <p style="margin: 0;">PUBLIC WORKS DEPARTMENT - LAND DEVELOPMENT DIVISION</p>	
	APPROVED: <div style="display: flex; justify-content: space-between;"> <div style="text-align: center;">             PUBLIC WORKS DIRECTOR /            CITY ENGINEER         </div> <div style="text-align: center;">           2/4/22            DATE         </div> </div>	<p><b>STANDARD GRADING NOTES</b>  <b>(FOR LAND DEVELOPMENT DIVISION)</b></p>	STANDARD PLAN <b>MVSI-166C-2</b>

**STANDARD PRECISE GRADING NOTES (LAND DEVELOPMENT DIVISION):**

1. ALL IMPROVEMENTS AS SHOWN ON THIS PLAN WERE PREPARED UNDER THE SUPERVISION OF THE ENGINEER OF RECORD AND IT CONFORMS TO THE LATEST EDITION OF THE CALIFORNIA BUILDING CODE (CBC) AS MODIFIED BY CITY OF MORENO VALLEY ORDINANCE, AND THE INTERIM GUIDELINES.
2. ALL GRADING SHALL BE COMPLETED UNDER THE SUPERVISION OF A REGISTERED SOILS ENGINEER OF RECORD IN CONFORMANCE WITH THE PRELIMINARY GEOTECHNICAL (SOILS) INVESTIGATION BY \_\_\_\_\_ DATED \_\_\_\_\_.
3. THE SOILS COMPACTION REPORT SHALL REFLECT THAT THE COMPACTION HAS BEEN OBTAINED NOT ONLY IN THE BUILDING PAD AREAS, BUT ALSO IN THE REMAINDER OF THE SITE, INCLUDING SLOPES.
4. THE ENGINEER OF RECORD SHALL CERTIFY THAT THE ROUGH GRADING SOIL COMPACTION HAS BEEN COMPLETED PER NOTE 1 AND 2 ABOVE, AND THAT THE SITE CONFORMS TO THE APPROVED PLAN AS TO LINE AND GRADE PRIOR TO THE RELEASE OF THE BUILDING PERMIT.
5. THE ENGINEER OF RECORD SHALL CERTIFY THAT THE FINAL GRADING CONFORMS TO APPENDIX J OF THE LATEST EDITION OF THE CALIFORNIA BUILDING CODE (CBC) AND THE APPROVED PLAN PRIOR TO THE RELEASE OF OCCUPANCY.
6. A CERTIFICATE SHALL BE PROVIDED CERTIFYING THAT ALL IMPORTED SOIL IS FREE FROM CONTAMINANTS PRIOR TO UNLOADING.
7. THE SOILS ENGINEER OF RECORD SHALL TEST AND CERTIFY ALL TRENCH BACKFILLS TO NO LESS THAN 90% MAXIMUM DENSITY AS DETERMINED BY SOIL COMPACTION TEST ASTM-D1557.
8. THE TOP 3 FEET OF SUBGRADE BELOW THE STREET PAVEMENT STRUCTURAL SECTION SHALL BE COMPACTED TO 95% RELATIVE COMPACTION.
9. FILL PLACED OVER EXISTING SLOPING TERRAIN SHALL BE SUPPORTED ON HORIZONTAL BENCH CUT INTO COMPETENT MATERIAL.
10. A SEPARATE BUILDING PERMIT SHALL BE REQUIRED FOR ALL ONSITE SEWER/WATER INSTALLATIONS, WALLS, AND/OR FENCES.
11. A SEPARATE ENCROACHMENT PERMIT SHALL BE REQUIRED FOR ANY CONSTRUCTION WITHIN THE PUBLIC RIGHT-OF-WAY.

NOT TO SCALE

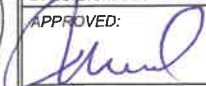

	RECOMMENDED: <i>CMG</i> DIVISION MANAGER DATE <i>1-28-22</i>	<b>CITY OF MORENO VALLEY</b> PUBLIC WORKS DEPARTMENT - LAND DEVELOPMENT DIVISION
	APPROVED:  PUBLIC WORKS DIRECTOR / DATE CITY ENGINEER <i>2/4/22</i>	<b>STANDARD PRECISE GRADING NOTES (FOR LAND DEVELOPMENT DIVISION)</b>



**GENERAL STREET IMPROVEMENT NOTES:**  
**(FOR CITY CAPITAL IMPROVEMENT PROJECTS )**

1. ALL WORK SHALL CONFORM TO THE CONTRACT DOCUMENTS IN EFFECT AT THE TIME OF BID, THE CITY OF MORENO VALLEY "STANDARD PLANS," AND OTHER AGENCIES' APPLICABLE "STANDARD PLANS" AS NOTED ON THE PLANS AND IN THE SPECIAL PROVISIONS.
2. ALL TRAFFIC SIGNAL WORK SHALL CONFORM TO THE CONTRACT DOCUMENTS IN EFFECT AT THE TIME OF BID, SECTION 86 "SIGNALS AND LIGHTING" OF CALTRANS STANDARD SPECIFICATIONS, CALTRANS STANDARD PLANS, AND THE SPECIAL PROVISIONS.
3. TRAFFIC CONTROL SHALL BE IN ACCORDANCE WITH THE CALIFORNIA M.U.T.C.D. PART 6 "TEMPORARY TRAFFIC CONTROL".
4. PRIOR TO CONSTRUCTION, THE CONTRACTOR SHALL OBTAIN A CITY OF MORENO VALLEY BUSINESS LICENSE AND ENCROACHMENT PERMIT.
5. PRIOR TO START OF CONSTRUCTION, THE CONTRACTOR SHALL CONTACT UNDERGROUND SERVICE ALERT, PROVIDE ALERT NUMBER TO CITY ENGINEER AND ALL NECESSARY UTILITY COMPANIES.
6. PRIOR TO CONSTRUCTION, THE CONTRACTOR SHALL FILE AN APPLICATION FOR A FIRE HYDRANT METER WITH THE APPROPRIATE WATER AGENCY.
7. REQUEST FOR INSPECTION TO THE CITY OF MORENO VALLEY SHALL BE MADE BY THE CONTRACTOR AT LEAST TWENTY-FOUR (24) HOURS BEFORE THE SERVICES THEREOF WILL BE REQUIRED AT (951) 413-3130.
8. WORK IN PUBLIC STREETS, ONCE BEGUN, SHALL BE WITHOUT DELAY SO AS TO PROVIDE MINIMUM INCONVENIENCE TO ADJACENT PROPERTY OWNERS AND TO THE TRAVELING PUBLIC. FAILURE TO COMPLY WILL BE A VIOLATION OF THE CONTRACT. CONTRACTOR SHALL PROVIDE ACCESS TO RESIDENCES AND BUSINESSES AT ALL TIMES.
9. NO PUBLIC TRAVELED STREET SHALL BE CLOSED TO TRAFFIC WITHOUT PRIOR CITY COUNCIL APPROVAL.
10. PROVISIONS SHALL BE MADE BY THE CONTRACTOR AT ALL TIMES FOR CONTRIBUTORY DRAINAGE.
11. THE EXISTENCE AND LOCATION OF ANY UNDERGROUND UTILITY PIPES, CONDUITS OR STRUCTURES SHOWN ON THESE PLANS WERE OBTAINED BY A SEARCH OF AVAILABLE RECORDS, THESE LOCATIONS ARE APPROXIMATE. THE CONTRACTOR IS REQUIRED TO TAKE DUE PRECAUTIONARY MEASURES TO PROTECT ANY UTILITY LINES SHOWN AND OTHER LINES NOT ON RECORD OR NOT SHOWN ON THESE PLANS.
12. THE CONTRACTOR SHALL EXCAVATE INSPECTION HOLES (POT HOLES) AND DETERMINE THE LOCATION AND DEPTH OF ALL UNDERGROUND STRUCTURES AND UTILITIES THAT ARE IN THE VICINITY OF OR THAT MAY BE AFFECTED BY THE PROPOSED IMPROVEMENT WORK PRIOR TO ANY CONSTRUCTION WORK WHICH COULD DAMAGE OR CONFLICT WITH SAID STRUCTURES OR UTILITIES.
13. THE CONTRACTOR SHALL PROTECT IN PLACE ALL EXISTING TRAFFIC SIGNAL CONDUIT WITHIN 6" ABOVE PROPOSED SUB GRADE SURFACE AND ALL CONDUIT BELOW PROPOSED SUBGRADE SURFACE. ALL EXISTING CONDUIT THAT IS MORE THAN 6" ABOVE THE PROPOSED SUBGRADE SURFACE SHALL BE RELOCATED TO WITHIN 6" BELOW PROPOSED SUBGRADE SURFACE.
14. THE CONTRACTOR SHALL NOTIFY THE ENGINEER IMMEDIATELY IF THE IMPROVEMENTS CONFLICT WITH EXISTING FACILITIES AND WORK IN THE CONFLICTING LOCATION SHALL STOP.
15. ANY ALTERATIONS OR VARIANCES FROM THE PLANS, EXCEPT MINOR ADJUSTMENTS IN THE FIELD TO MEET EXISTING CONDITIONS, SHALL BE REQUESTED IN WRITING AND MAY NOT BE INSTITUTED UNTIL APPROVED BY THE CITY ENGINEER OR REPRESENTATIVES ACTING SPECIFICALLY ON THE CITY ENGINEERS INSTRUCTIONS.
16. INSPECTION BY THE CITY INSPECTOR SHALL NOT, IN ANY WAY, RELIEVE THE CONTRACTOR OF HIS/HER OBLIGATIONS TO COMPLETELY AND DILIGENTLY PERFORM ALL WORK IN COMPLIANCE WITH THE APPROVED PLANS AND SPECIFICATIONS.
17. ALL ELEVATIONS SHOWN ON THE PLANS ARE ESTABLISHED BY LOCAL BENCH MARKS. SURVEY MONUMENTS SHALL BE PROTECTED IN PLACE.
18. ALL AC AND PCC SHALL BE SAWCUT UNLESS OTHERWISE SPECIFIED.
19. NO TRENCHES EXCEPT CURB AND GUTTER, SHALL BE LEFT OPEN OVERNIGHT UNLESS APPROVED BY THE CITY ENGINEER IN WRITING.
20. ALL UTILITIES SHALL BE INSTALLED, INSPECTED, TESTED AND APPROVED BY THE APPROPRIATE UTILITY COMPANY PRIOR TO PAVING. PROOF OF SUCH INSPECTION/APPROVAL SHALL BE SUPPLIED TO THE CITY INSPECTOR OR REPRESENTATIVE.
21. IRRIGATION LINES WITHIN ANY CITY STREET SHALL HAVE A 30" MINIMUM COVER FROM FINISH SURFACE, UNLESS SAID IRRIGATION LINE HAS BEEN APPROVED BY THE CITY ENGINEER IN WRITING TO BE ENCASED IN CONCRETE OR BEDDED IN A SPECIAL CONCRETE CRADLE.
22. THE CONTRACTOR SHALL COMPACT THE UPPER SIX INCHES OF SUBGRADE/AGGREGATE BASE TO A MINIMUM RELATIVE DENSITY OF 90/95 PERCENT RESPECTIVELY PER ASTM 1556-82 TESTING METHOD, OR AS DIRECTED BY THE ENGINEER.

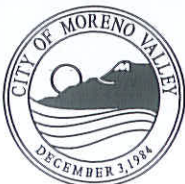
NOT TO SCALE

	RECOMMENDED: 	<h2 style="margin: 0;">CITY OF MORENO VALLEY</h2> <p style="margin: 0;">PUBLIC WORKS DEPARTMENT - CAPITAL PROJECTS DIVISION</p>	
	DIVISION MANAGER DATE 1/21/14	APPROVED: 	<h3 style="margin: 0;">GENERAL STREET IMPROVEMENT NOTES</h3> <p style="margin: 0;">(FOR CITY CAPITAL IMPROVEMENT PROJECTS)</p>
	PUBLIC WORKS DIRECTOR / CITY ENGINEER DATE 1/29/14	STANDARD PLAN <h2 style="margin: 0;">MVSI-167A-0</h2>	SHEET 1 OF 2

**GENERAL STREET IMPROVEMENT NOTES:**  
**(FOR CITY CAPITAL IMPROVEMENT PROJECTS)**

23. SUBGRADE MATERIAL PLACED FOR CURBS, GUTTERS, DRIVEWAY APPROACHES, AND SIDEWALKS SHALL BE TO A RELATIVE COMPACTION OF 90 PERCENT.
24. ALL PORTLAND CEMENT CONCRETE (PCC) REMOVALS, INCLUDING, BUT NOT LIMITED TO CROSS GUTTERS, CURBS, DRIVEWAY APPROACHES, SIDEWALK, AND SPANDRELS SHALL BE MADE BY REMOVING AND REPLACING THE ENTIRE SECTION BETWEEN JOINTS. IF ANY UTILITY CUTS ARE MADE IN PCC IMPROVEMENTS, THE ENTIRE SECTION SHALL BE REMOVED AND REPLACED.
25. CONCRETE SIDEWALKS, CURBS AND GUTTERS, OR OTHER CONCRETE STRUCTURES WHICH WILL NOT BE SUBJECTED TO VEHICULAR TRAFFIC, SHALL BE BARRICADED FOR A PERIOD OF AT LEAST SEVEN (7) DAYS FOLLOWING PLACEMENT OF THE SAID CONCRETE STRUCTURE. FOR DRIVEWAYS, CROSS GUTTERS, SPANDRELS OR OTHER STRUCTURES WHICH WILL BE SUBJECTED TO VEHICULAR TRAFFIC, THE CONTRACTOR SHALL USE CONCRETE CONTAINING EIGHT SACKS OF CEMENT AND ADDITIVES THAT PROVIDE HIGH EARLY STRENGTH IN ORDER TO UTILIZE EARLIER USE OF CONSTRUCTED FACILITIES, AS EARLY AS 24-HOUR AFTER PLACING OF CONCRETE. THE CONTRACTOR SHALL OBTAIN WRITTEN APPROVAL FROM THE CITY ENGINEER FOR TRAFFIC USE TO BE PERMITTED THEREON TWENTY-FOUR HOURS AFTER THE PLACING OF CONCRETE.
26. ALL TRAFFIC CONTROL DEVICES AND SIGNS SHALL BE IN PLACE AND APPROVED BY THE CITY PRIOR TO PAVING. DELINEATION SHALL BE COMPLETED PRIOR TO STREET OPEN.
27. THE CONTRACTOR SHALL NOT PLACE ASPHALT CONCRETE PAVING UNTIL SUBGRADE OR AGGREGATE BASE HAS BEEN INSPECTED AND APPROVED BY THE CITY AND SHALL INCLUDE A COPY OF THE CERTIFICATION OF BASE/COMPACTION BY THE GEOTECHNICAL ENGINEER.
28. THE CONTRACTOR SHALL PLACE THE ARHM FINISH SURFACE COURSE PAVING AFTER ALL BASE COURSE PAVING HAS BEEN COMPLETED. TACK COAT SHALL BE PLACED BETWEEN ALL COURSES OF PAVING.
29. THE CONTRACTOR SHALL ADJUST WATER VALVE COVERS TO FINISH GRADE DURING PAVING, LOOSEN AFTER PAVING, AND PAINT BLUE.
30. BLUE DOTS SHALL BE INSTALLED TO INDICATE THE LOCATION OF FIRE HYDRANTS.
31. ALL TREE BRANCHES OVERHANGING THE SIDEWALK SHALL BE TRIMMED CLEAR TO A MINIMUM HEIGHT OF 10 FEET ABOVE FINISHED SURFACE/GROUND SURFACE AND BRANCHES OVERHANGING THE ROADWAY SHALL BE TRIMMED CLEAR TO A MINIMUM HEIGHT OF 18 FEET.
32. ALL IRRIGATION SHALL BE RELOCATED BEHIND IMPROVEMENTS, AND REPLACED WITH THE SAME STANDARD OF MATERIALS OR HIGHER. ALL LANDSCAPING SHALL COMPLY WITH THE CONTRACT DOCUMENTS.
33. ALL PAVEMENT REPAIR SURFACE COURSE SHALL BE PG 64-14 ASPHALT RUBBER HOT MIX (ARHM-GG-C), OR AS APPROVED BY THE CITY ENGINEER. SEE STANDARDS No MVSI-132, A THROUGH F. ARHM SHALL CONFORM TO SECTION 203-11 OF THE STANDARD SPECIFICATIONS FOR PUBLIC WORKS CONSTRUCTION, LATEST EDITION.

NOT TO SCALE



RECOMMENDED:  
*HN*      *10/14/20*  
 DIVISION MANAGER      DATE

APPROVED:  
*M. W. [Signature]*      *10/21/20*  
 PUBLIC WORKS DIRECTOR      DATE  
 CITY ENGINEER

**CITY OF MORENO VALLEY**

PUBLIC WORKS DEPARTMENT - CAPITAL PROJECTS DIVISION

**GENERAL STREET  
 IMPROVEMENT NOTES**

**(FOR CITY CAPITAL IMPROVEMENT PROJECTS)**

STANDARD PLAN

**MVSI-167B-1**

SHEET 2 OF 2









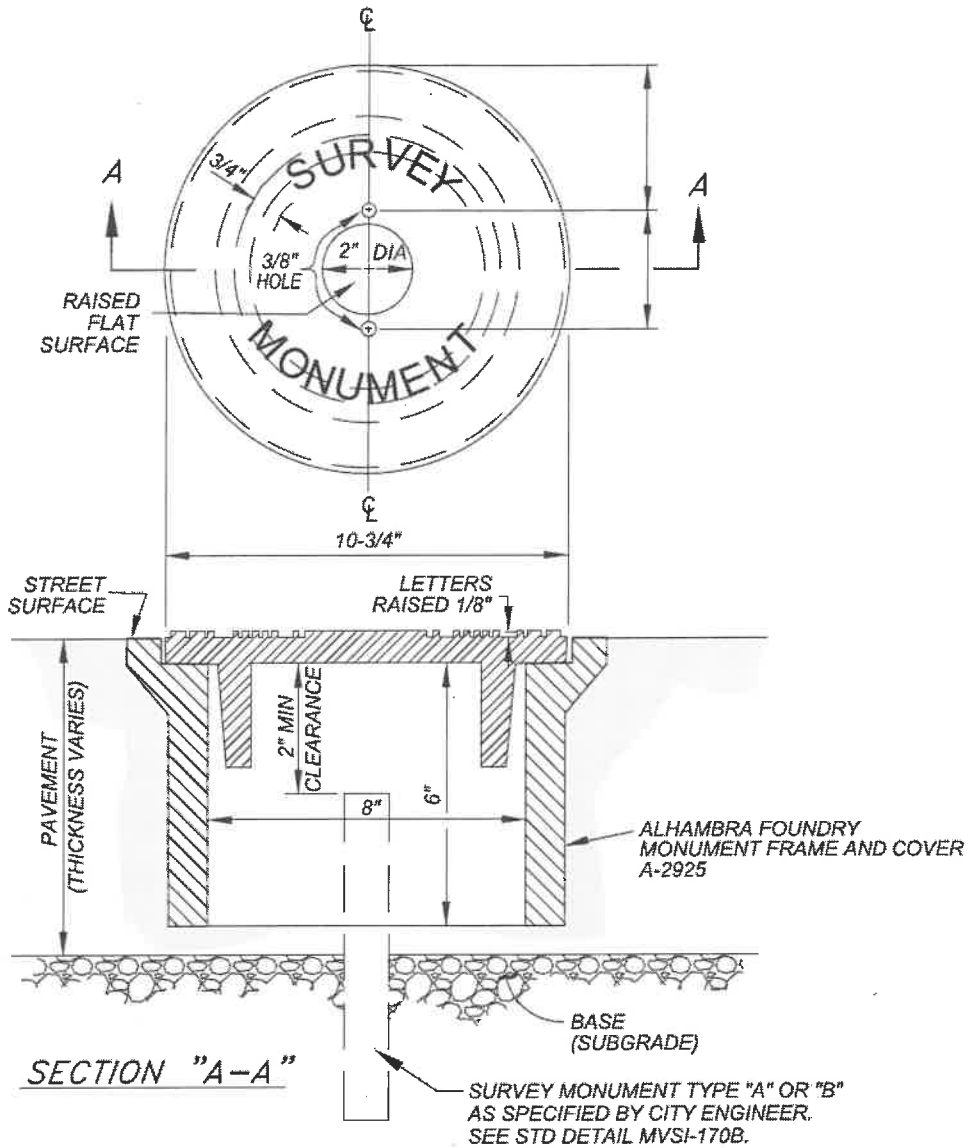

**NOTES:**

- 1.) CAST IRON SHALL CONFORM TO SECTION 206-3 OF "STANDARD SPECIFICATIONS FOR PUBLIC WORKS CONSTRUCTION."
- 2.) LETTERING SHALL BE AS SHOWN HEREON, 1/8" HIGH, AND SHALL BE CAST INTEGRAL WITH THE CASTING.
- 3.) THE 3/8" DIAMETER HOLES IN THE COVER SHALL BE AS SHOWN HEREON, AND SHALL EITHER BE FORMED BY PROVIDING A REMOVABLE PLUG PRIOR TO CASTING OR DRILLED AFTER CASTING HAS COOLED AND BEFORE COATING IS APPLIED. THE HOLES SHALL NOT BE PUNCHED.
- 4.) AFTER CASTING HAS COOLED, IT SHALL BE GIVEN AN ASPHALTIC COATING CONFORMING TO SECTION 206-3.6 OF THE STANDARD SPECIFICATIONS.
- 5.) DURING INSTALLATION, WHEN THE PAVEMENT IS FOUND TO BE LESS THAN 6-5/8" THICK, THE BASE OF THE MONUMENT COVER SHALL BE CUT SO THAT IT DOES NOT EXTEND INTO THE BASE. APPLY A COAT OF ASPHALTIC COATING OR ASPHALT PAINT TO ANY UNCOATED SURFACE OR CUTEDGE.
- 6.) MONUMENTS AT STREET INTERSECTIONS, COLLECTORS AND ABOVE, SHALL HAVE MONUMENT COVERS.

NOT TO SCALE

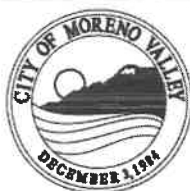

RECOMMENDED:

*WJL*  
DIVISION MANAGER

*7/24/9*  
DATE

APPROVED:

*M.L. Woff* *7/30/9*  
PUBLIC WORKS DIRECTOR / DATE  
CITY ENGINEER

**CITY OF MORENO VALLEY**  
PUBLIC WORKS DEPARTMENT - LAND DEVELOPMENT DIVISION

**MONUMENT COVER**

STANDARD PLAN  
**MVSI-170A-1**

SHEET 1 OF 5

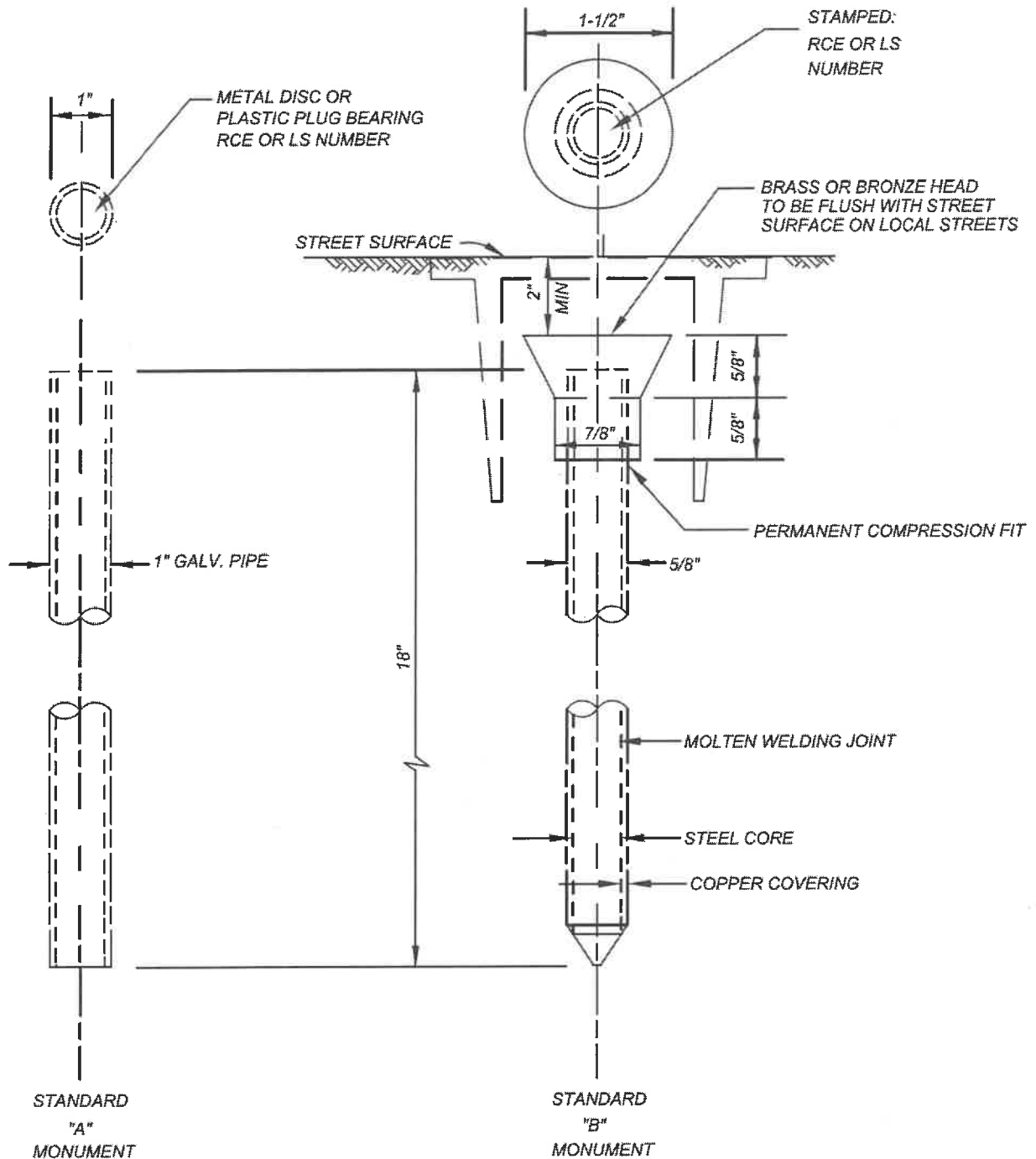

**NOTES:**

- 1.) SEE STD No MVSI-170E FOR TIE-OUT/MONUMENT NOTES.
- 2.) MONUMENTS AT STREET INTERSECTIONS, STANDARD KNUCKLE INTERSECTION, AND CUL-DE-SAC RADIAL POINTS SHALL HAVE MONUMENT COVERS.

NOT TO SCALE

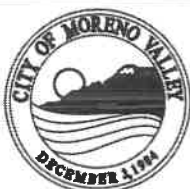

RECOMMENDED:

*MDL* 7/2/19  
DIVISION MANAGER DATE

APPROVED:

*Mt. Wolfe* 7/30/19  
PUBLIC WORKS DIRECTOR / DATE  
CITY ENGINEER

**CITY OF MORENO VALLEY**

PUBLIC WORKS DEPARTMENT - LAND DEVELOPMENT DIVISION

**SURVEY MONUMENT**

STANDARD PLAN

**MVSI-170B-0**

SHEET 2 OF 5



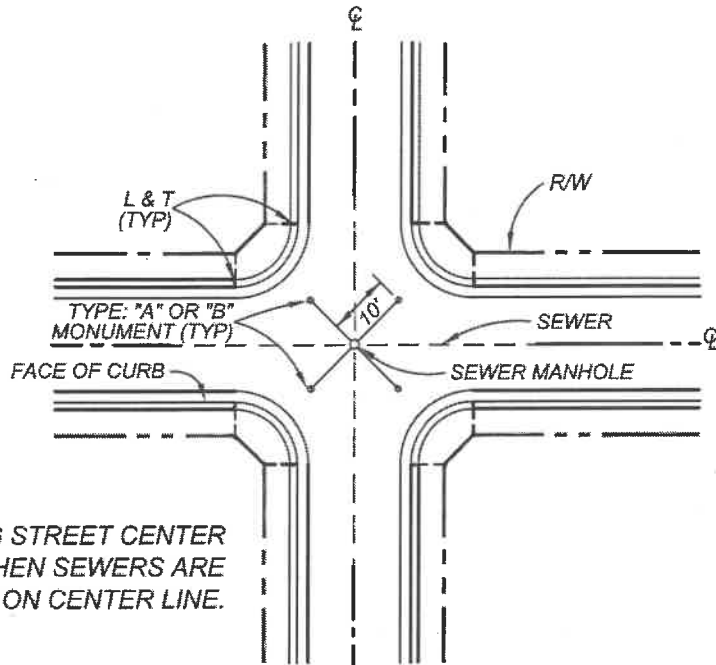

MONUMENTING STREET CENTER LINES WHEN SEWERS ARE LOCATED ON CENTER LINE.

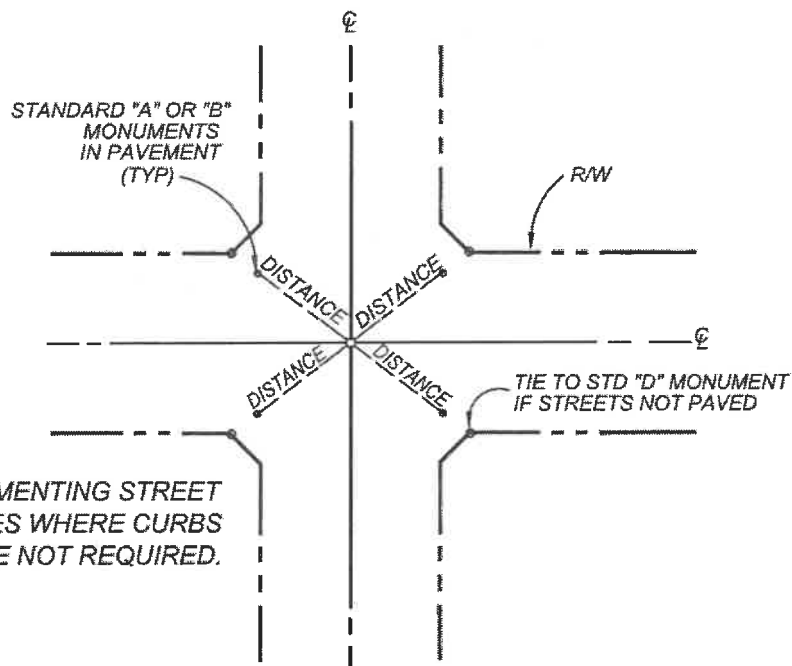

MONUMENTING STREET CENTER LINES WHERE CURBS ARE NOT REQUIRED.

**NOTES:**

- 1.) L & T AS SHOWN HEREON INDICATES LEAD AND TACK OR STEEL PIN MONUMENT SET IN CURB.
- 2.) LEAD AND TACK OR STEEL PIN MONUMENT WITNESS TO PROPERTY CORNER MAY BE SET, NOT REQUIRED.
- 3.) SEE STD No MVS1-170B FOR TYPE "A" AND TYPE "B" MONUMENT.
- 4.) SEE STD No MVS1-170E FOR TIE-OUT/MONUMENT NOTES.

NOT TO SCALE

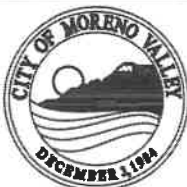

RECOMMENDED:  
*WDL* 7/8/19  
 DIVISION MANAGER DATE  
 APPROVED:  
*Mt. Wyle* 7/30/19  
 PUBLIC WORKS DIRECTOR / DATE  
 CITY ENGINEER

**CITY OF MORENO VALLEY**  
 PUBLIC WORKS DEPARTMENT - LAND DEVELOPMENT DIVISION

**TIE-OUT STANDARDS**

STANDARD PLAN  
**MVSI-170C-0**

SHEET 3 OF 5

MONUMENTING STREET INTERSECTIONS WHERE CURB AND GUTTERS ARE INSTALLED

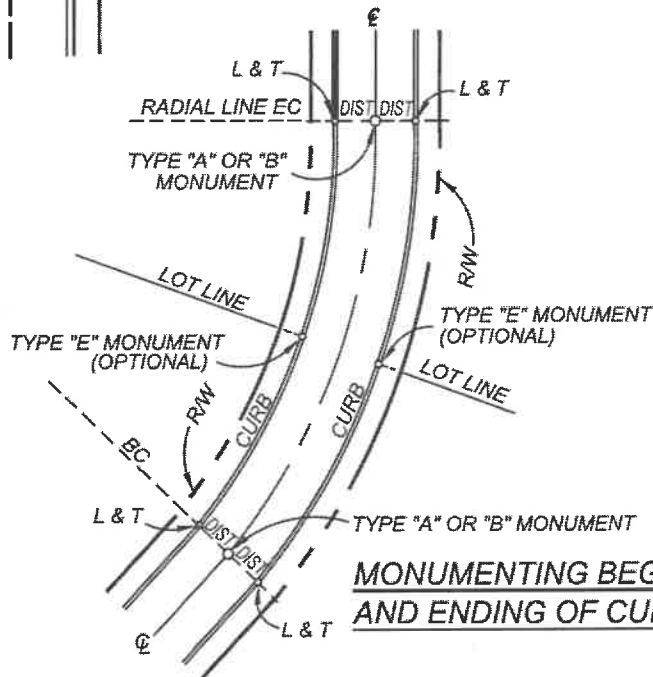
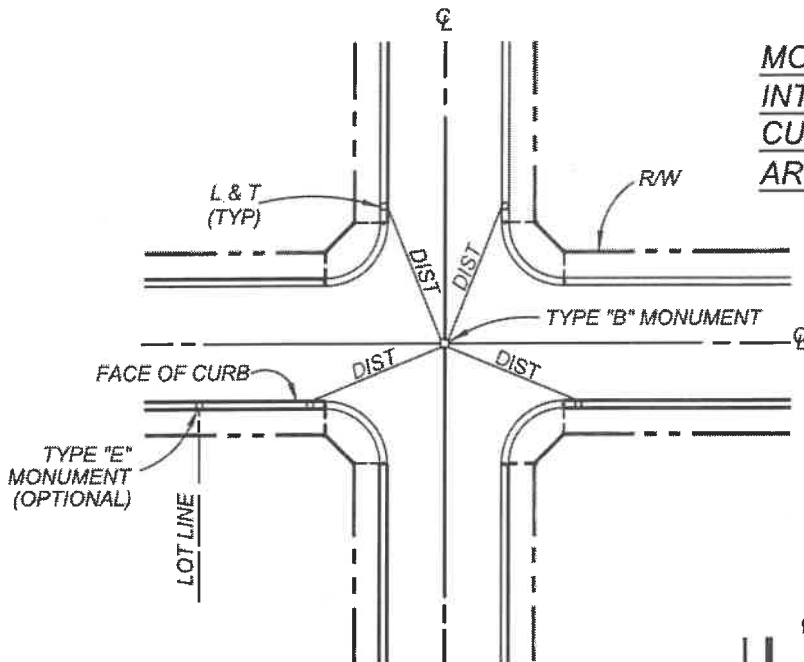

MONUMENTING BEGINNING AND ENDING OF CURVE

**NOTES:**

- 1.) L & T SHOWN HEREON INDICATES LEAD AND TACK OR STEEL PIN MONUMENT SET IN CONCRETE CURB.
- 2.) LEAD AND TACK OR STEEL PIN MONUMENT WITNESS TO PROPERTY CORNER MAY BE SET ( "E" MONUMENT ) IN LIEU OF SETTING FRONT LOT CORNERS.
- 3.) THE PI OF THE CURVE C OF A STREET MAY BE MONUMENTED IN LIEU OF EC AND BC IF THE PI FALLS WITHIN THE TRAVELED WAY. IT SHALL BE REFERENCED WITH L & T's IN CURB.
- 4.) SEE STD MVS1-170B AND MVS1-170E FOR TIE-OUT/MONUMENT NOTES.

NOT TO SCALE

	RECOMMENDED: <i>M.D.L.</i> 7/2/19 DIVISION MANAGER      DATE	<h2 style="margin: 0;">CITY OF MORENO VALLEY</h2> <p style="margin: 0;">PUBLIC WORKS DEPARTMENT - LAND DEVELOPMENT DIVISION</p>	STANDARD PLAN <b>MVSI-170D-0</b>
	APPROVED: <i>M.L. Wolfe</i> 7/30/19 PUBLIC WORKS DIRECTOR / DATE CITY ENGINEER	<h3 style="margin: 0;">STREET CENTERLINE MONUMENT</h3>	SHEET 4 OF 5



**NOTES:**

- 1.) **GENERAL REQUIREMENTS:** THE SUBDIVISION BOUNDARIES, LOT CORNERS, CITY LIMITS, ROAD, STREET, HIGHWAY CENTERLINE, ANGLE POINTS IN ALL LINES, BEGINNING AND END OF ALL CURVED LINES, SHALL BE MONUMENTED IN ACCORDANCE WITH THE HEREINAFTER DESCRIBED STANDARD MONUMENTS AND PROCEDURES. ANY MONUMENT HAVING CHARACTERISTICS OTHER THAN THE HEREINAFTER DESCRIBED MAY BE USED ONLY UPON WRITTEN APPROVAL OF THE CITY ENGINEER. IF AN EXISTING RECORD AND IDENTIFIED MONUMENT IS FOUND ON THE GROUND AT THE LOCATION OF A SUBDIVISION CORNER, THIS MONUMENT MAY BE USED IN LIEU OF REPLACEMENT WITH A NEW MONUMENT PROVIDED THE EXISTING MONUMENT IS A TYPE CONSIDERED TO BE DURABLE.
- 2.) **STANDARD "A" MONUMENTS:** THIS MONUMENT IS TO BE ONE INCH ( INSIDE DIAMETER ) GALVANIZED IRON PIPE EIGHTEEN (18") INCHES LONG. A METAL DISC OR PLASTIC PLUG BEARING THE REGISTERED CIVIL ENGINEER OR LAND SURVEYOR NUMBER SHALL BE SECURELY AFFIXED TO THE TOP OF THE PIPE. THE TOP SURFACE OF THE MONUMENT SHALL BE 2 2/3" MINIMUM BELOW THE PAVED STREET SURFACE WITH MONUMENT COVER. SEE STANDARD PLANS No's MVSI-170A AND MVSI-170B. THIS MONUMENT IS NOT TO BE USED WITHOUT A MONUMENT COVER.
- 3.) **STANDARD "B" MONUMENTS:** THIS MONUMENT IS TO BE AN EIGHTEEN (18") INCH COPPER CLAD STEEL PIN WITH ONE-HALF (1-1/2") INCH CONICAL BRASS CAP. THE MONUMENT MAY BE USED AS AN ALTERNATIVE TO THE TYPE "A" MONUMENT TO MARK CENTERLINE CONTROL IN PAVED STREETS. THE MONUMENT IS TO BE DRIVEN 2" MINIMUM BELOW THE STREET SURFACE WITH MONUMENT COVER. AFTER SETTING THE MONUMENT, THE REGISTERED CIVIL ENGINEER OR LAND SURVEYOR NUMBER SHALL BE STAMPED INTO THE SURFACE OF THE BRASS CAP. SEE STANDARD PLAN No's MVSI-170A AND MVSI-170B. THIS MONUMENT SHALL BE FLUSH WITH STREET SURFACE WHEN PLACED IN LOCAL STREETS.
- 4.) **STANDARD "C" MONUMENTS:** THIS MONUMENT TO CONSIST OF A 1/2" REBAR, 18" LONG WITH APPROPRIATE STAMPED CAP. SEE MONUMENT SCHEDULE BELOW FOR USE OF THIS MONUMENT.
- 5.) **STANDARD "D" MONUMENTS:** THIS MONUMENT TO CONSIST OF A 3/4" INSIDE DIAMETER x 18" LONG GALVANIZED IRON PIPE DRIVEN TO A POINT NOT TO EXCEED 1" ABOVE THE NATURAL GROUND SURFACE. THE EXACT POINT OF INTERSECTION OF THE LINES SHALL BE MARKED AS SHOWN ON STANDARD MVSI-170C-0, AND ON THE TOP CENTER OF THE PIPE BY A SUITABLE TACK OR NAIL, WHICH IN TURN SHALL BE USED TO SECURE TO THE STAKE THE METAL DISK BEARING THE REGISTERED CIVIL ENGINEER OR LAND SURVEYOR NUMBER OR PLASTIC PLUG WITH RCE OR LS NUMBER. SEE MONUMENT SCHEDULE BELOW FOR USE OF THIS MONUMENT.
- 6.) **STANDARD "E" MONUMENTS:** THIS MONUMENT TO CONSIST OF LEAD PLUG OR STEEL PIN WITH METAL IDENTIFICATION DISK SET IN CONCRETE CURB. SEE MONUMENT SCHEDULE BELOW FOR USE OF THIS MONUMENT.
- 7.) **MONUMENT SCHEDULE:**

STANDARD	USE OF MONUMENT	REMARKS
"A"	TRACT BOUNDARY CONTROL: STREET CENTERLINE CONTROL--UNPAVED AND PAVED	AS SPECIFIED BY THE CITY ENGINEER.
"B"	STREET CENTERLINE CONTROL	MAY BE USED IN LIEU OF TYPE "A" MONUMENT IN PAVED STREETS. TYPE "B" SHALL BE USED AT ALL STREET INTERSECTIONS
"C"	LOT CORNER ANGLE POINT IN LOT LINE, EC AND BC, LOT LINE, RIGHT-OF-WAY LINE	
"D"	SAME AS "C"	
"E"	SAME AS "C"	ALL LOT CORNER MONUMENT EXCEPT WHEN LOT CORNER IS COINCIDENT WITH BOUNDARY CORNER MAY BE SET IN THE FACE OF THE CURB ON THE PROLONGATION OF THE LOT LINE. IN THE EVENT IMPROVEMENTS IN A SUBDIVISION INCLUDE A BLOCK WALL ALONG THE REAR LOT LINES, A STANDARD "E" MONUMENT MAY BE SET ON BOTH SIDES OF THE BLOCK WALL TO INDICATE DIRECTION OF THE SIDE LOT LINES. SUCH POINTS SHALL BE NOTED ON THE FINAL MAP AS "POINTS ON LINE".

- 8.) **MONUMENTS TIES:** UPON COMPLETION OF THE TRACT MONUMENTATION, THE ENGINEER OR LICENSED LAND SURVEYOR SHALL FURNISH TO THE CITY ENGINEER TIES TO ALL STREET CENTERLINE MONUMENTS. SUCH TIES ARE TO BE PERMANENT PHYSICAL OBJECTS, THERE BEING NOT LESS THAN 3 AND PREFERABLY 4 TIES TO EACH MONUMENT. WHENEVER CURB AND GUTTER IS INSTALLED, STREET CENTERLINE MONUMENTS ARE TO BE TIED TO PERMANENT POINTS SET IN THE CURB. THESE PERMANENT POINTS TO CONSIST OF EITHER OF THE FOLLOWING: LEAD AND TACK OR STEEL PIN DRIVEN INTO THE CONCRETE. USE OF A CROSS CUT INTO THE CONCRETE WILL NOT BE ACCEPTABLE. CROSS OVER TIES ARE PREFERRED WHEN MADE WITH TRANSIT AND TAPE. THE TIES FURNISHED TO THE CITY ENGINEER ARE TO BE PREPARED ON 8-1/2" x 11" SHEETS OF MYLAR. SKETCH TO BE CLEAR AND LEGIBLE AND SPACED TO AVOID CONFUSION OR MISINTERPRETATION.

NOT TO SCALE

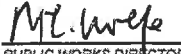
	RECOMMENDED:  DIVISION MANAGER	7/8/19 DATE	<b>CITY OF MORENO VALLEY</b> PUBLIC WORKS DEPARTMENT - LAND DEVELOPMENT DIVISION	STANDARD PLAN <b>MVSI-170E-0</b>
	APPROVED:  PUBLIC WORKS DIRECTOR / CITY ENGINEER	7/30/19 DATE		

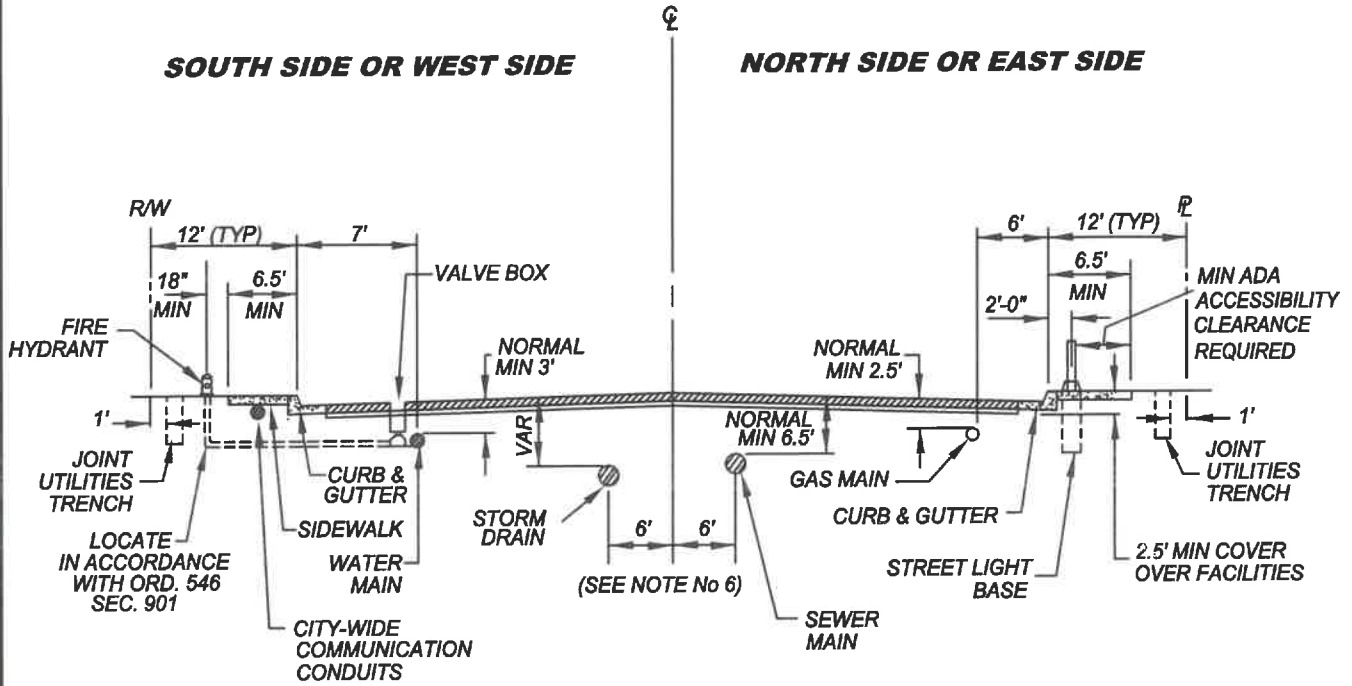

**NOTES:**

- 1.) LOCATION AND DEPTH OF EXISTING AND PROPOSED UTILITIES MUST BE PROVIDED BY THE SUBDIVIDER AND SHOWN ON ANY PLANS SUBMITTED TO THE CITY ENGINEER FOR APPROVAL.
- 2.) CHANGES MAY BE PERMITTED BY CITY ENGINEER IN CASES OF CONFLICTING FACILITIES.
- 3.) CONFLICTS BETWEEN UTILITY COMPANIES FACILITIES, EXISTING AND PROPOSED, MUST BE MUTUALLY RESOLVED BY THE UTILITY COMPANIES.
- 4.) FOR COMMERCIAL SIDEWALKS, THE FIRE HYDRANT SHALL BE PLACED WITHIN THE SIDEWALK 1.5' BEHIND FACE OF CURB.
- 5.) SEE STD No's MVL-400A AND MVL-400B FOR LIGHTING DETAILS.
- 6.) FOR STREETS WITH RAISED MEDIANS, THE OFFSET DISTANCES OF STORM DRAIN AND SEWER MAIN FROM THE STREET CENTERLINE SHALL BE PER THE CITY ENGINEER'S REVIEW AND APPROVAL.
- 7.) ORANGE INSULATED COPPER CLAD STEEL TRACER WIRE PER KRISTECH SPECIFICATIONS SHEET, OR EQUAL. TRACER WIRE TO BE INSTALLED 2" ABOVE COMMUNICATION CONDUIT PER "THE COMPLETE UTILITY LOCATING SYSTEM SPECIFICATIONS FOR TELECOMMUNICATIONS" BY COPPERHEAD INDUSTRIES, OR EQUIVALENT.

NOT TO SCALE

	RECOMMENDED: <i>[Signature]</i> 12/16/21 DIVISION MANAGER DATE	<h2 style="margin: 0;">CITY OF MORENO VALLEY</h2> <p style="margin: 0;">PUBLIC WORKS DEPARTMENT - CAPITAL PROJECTS DIVISION</p>	STANDARD PLAN <h3 style="margin: 0;">MVSI-180A-1</h3>
	APPROVED: <i>[Signature]</i> 2/4/22 PUBLIC WORKS DIRECTOR/ DATE CITY ENGINEER	<h3 style="margin: 0;">NORMAL LOCATION OF UNDERGROUND UTILITIES</h3>	SHEET 1 OF 2



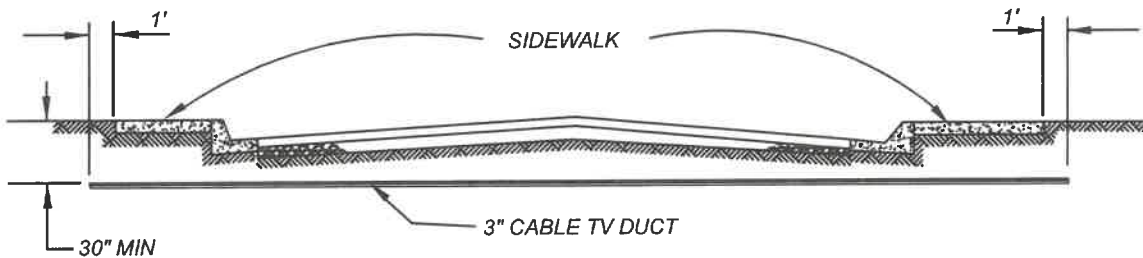
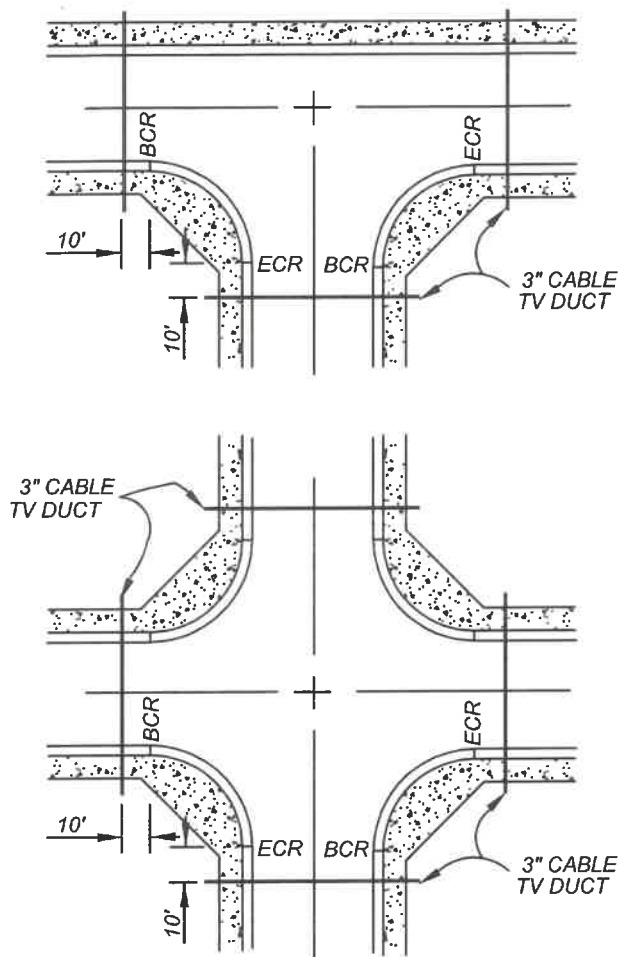

**TYPICAL CROSS SECTION**

**NOTE:**

1. ORANGE INSULATED COPPER CLAD STEEL TRACER WIRE PER KRISTECH SPECIFICATIONS SHEET, OR EQUAL. TRACER WIRE TO BE INSTALLED 2" ABOVE COMMUNICATION CONDUIT PER "THE COMPLETE UTILITY LOCATING SYSTEM SPECIFICATIONS FOR TELECOMMUNICATIONS" BY COPPERHEAD INDUSTRIES, OR EQUIVALENT.

NOT TO SCALE



RECOMMENDED:  
*Henrygo* 12/16/21  
 DIVISION MANAGER DATE

APPROVED:  
*Chenel* 2/4/22  
 PUBLIC WORKS DIRECTOR / DATE  
 CITY ENGINEER

**CITY OF MORENO VALLEY**  
 PUBLIC WORKS DEPARTMENT - CAPITAL PROJECTS DIVISION

**LOCATION OF CABLE TV  
 DUCTS AT STREET  
 INTERSECTIONS**

STANDARD PLAN  
**MVSI-180B-1**

SHEET 2 OF 2

REPLACE EXISTING LANDSCAPING AND IRRIGATION IN KIND

**TRENCH BACKFILL:**

1.5 SACK CEMENT SLURRY SHALL BE PLACED PRIOR TO THE END OF EACH WORK DAY UNLESS OTHERWISE APPROVED BY THE CITY ENGINEER. ALL COMPACTION SHALL BE BY MECHANICAL METHODS ONLY. JETTING, FLOODING OR PONDING WILL NOT BE ALLOWED UNLESS AUTHORIZED BY CITY ENGINEER. SEE SECTION 306-1.3, STANDARD SPECIFICATIONS FOR PUBLIC WORKS CONSTRUCTION, LATEST EDITION.

TOP 24"  
90% RELATIVE  
COMPACTION

36" MIN \*

12"

3" SAND BASE

BEDDING AND COVERING MATERIALS SHALL MEET OR EXCEED SECTION 306-1.2.1, STANDARD SPECIFICATIONS FOR PUBLIC WORKS CONSTRUCTION, LATEST EDITION. LOCALLY EXCAVATED NATIVE MATERIALS MAY BE BLENDED TO THE REQUIRED SAND EQUIVALENCY OF 30 OR GREATER.

\* 36" MIN FOR TRUNK AND DISTRIBUTION CONDUIT SYSTEM AND 18" MIN. FOR SERVICE LATERAL CONDUIT SYSTEM.

**NOTES:**

1. SEE STD No's MVSI-185A THROUGH MVSI-185D FOR TECHNICAL PROVISIONS OF COMMUNICATIONS FACILITIES.
2. ALL TRENCHING AND BACKFILL SHALL BE DONE IN ACCORDANCE WITH SECTION 306, STANDARD SPECIFICATIONS FOR PUBLIC WORKS CONSTRUCTION, LATEST EDITION.
3. FOUR-WAY CLIP SPACERS SHALL BE INSTALLED EVERY 50' TO HOLD CONDUITS IN A UNIFORM ORDER AS SHOWN THROUGH OUT THE LENGTH OF THE TRENCH.
4. ORANGE INSULATED COPPER CLAD STEEL TRACER WIRE PER KRISTECH SPECIFICATIONS SHEET, OR EQUAL. TRACER WIRE TO BE INSTALLED 2" ABOVE COMMUNICATION CONDUIT PER "THE COMPLETE UTILITY LOCATING SYSTEM SPECIFICATIONS FOR TELECOMMUNICATIONS" BY COPPERHEAD INDUSTRIES, OR EQUIVALENT.

NOT TO SCALE



RECOMMENDED:

*Honeygo* 12/16/21  
DIVISION MANAGER DATE

APPROVED:

*[Signature]* 2/4/22  
PUBLIC WORKS DIRECTOR / DATE  
CITY ENGINEER

**CITY OF MORENO VALLEY**

PUBLIC WORKS DEPARTMENT - CAPITAL PROJECTS DIVISION

**COMMUNICATIONS CONDUIT  
IN PARKWAY  
SEPARATE TRENCH DETAIL**

STANDARD PLAN

**MVSI-181A-1**

SHEET 1 OF 4

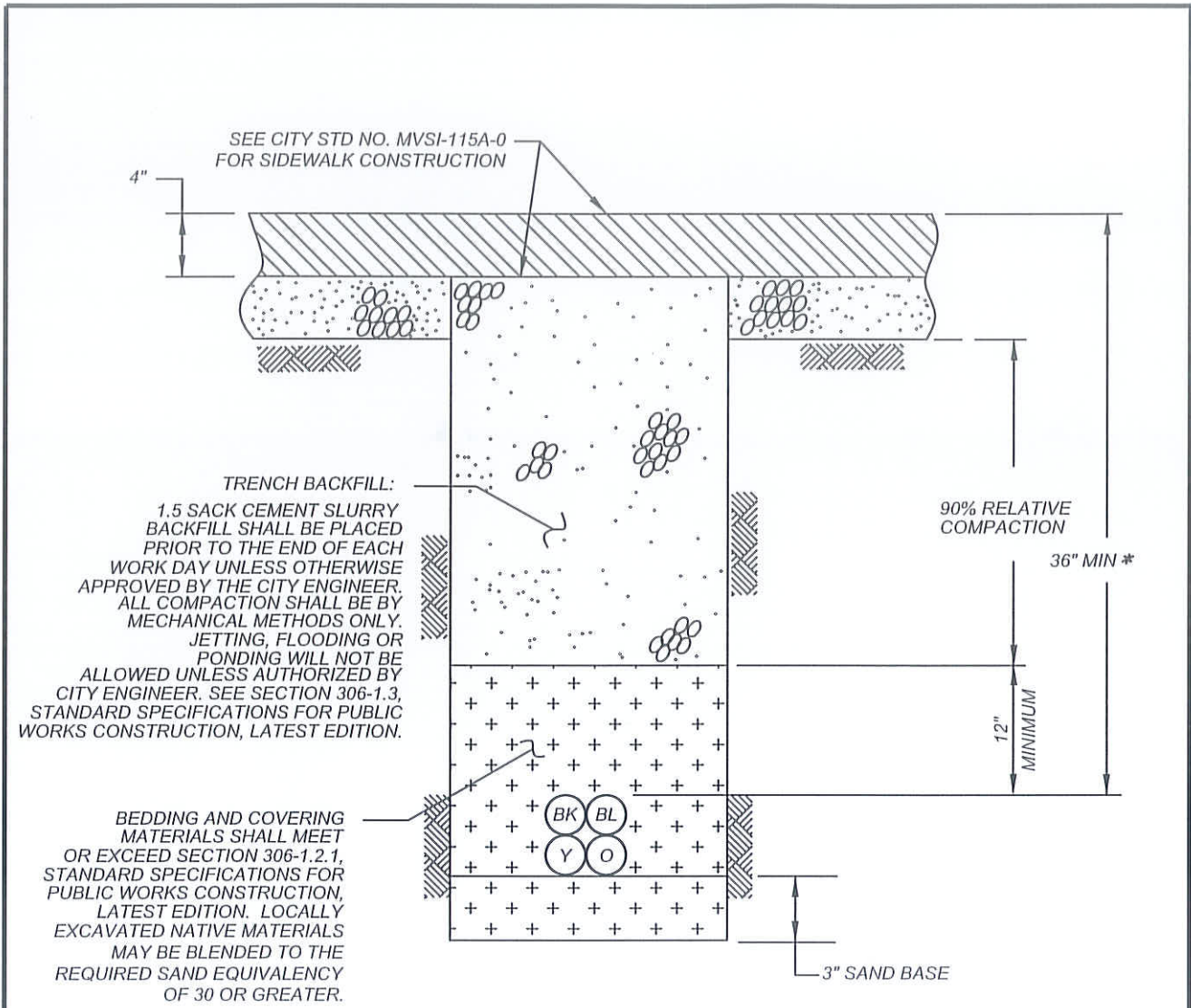



\* 36" MIN FOR TRUNK AND DISTRIBUTION CONDUIT SYSTEM AND 18" MIN FOR SERVICE LATERAL CONDUIT SYSTEM.

**NOTES:**

1. SEE STDS MVS-185A-0 ~ MVS-185D-0 FOR TECHNICAL PROVISIONS OF COMMUNICATIONS FACILITIES.
2. ALL TRENCHING AND BACKFILL SHALL BE DONE IN ACCORDANCE WITH SECTION 306, STANDARD SPECIFICATIONS FOR PUBLIC WORKS CONSTRUCTION, LATEST EDITION.
3. FOUR-WAY CLIP SPACERS SHALL BE INSTALLED EVERY 50' TO HOLD CONDUITS IN A UNIFORM ORDER AS SHOWN THROUGHOUT THE LENGTH OF THE TRENCH.

NOT TO SCALE

	RECOMMENDED:  DIVISION MANAGER / DATE 1/21/19	<b>CITY OF MORENO VALLEY</b> PUBLIC WORKS DEPARTMENT - CAPITAL PROJECTS DIVISION	
	APPROVED:  PUBLIC WORKS DIRECTOR / DATE 1/29/19 CITY ENGINEER	<b>COMMUNICATIONS CONDUIT IN SIDEWALK SEPARATE TRENCH DETAIL</b>	



FINISH OVERLAY TO BE PLACED NO LATER THAN 15 DAYS AFTER BASE PAVING. APPLY TACK AND LEVELING COURSE TO BRING WITHIN 0.10' OF EXISTING GRADE. SURFACE COURSE SHALL BE TYPE III C3-AR 4000 AC AND BASE COURSE B2-AR-4000 AC

ORANGE WARNING TAPE LIKE THOMAS AND BETTS 6" WIDE PLASTIC TAPE WITH SUITABLE WARNING LEGEND DESCRIBING BURIED TELECOMMUNICATIONS FACILITIES.

SAWCUT EXISTING PAVEMENT AND APPLY HEAVY ASPHALTIC TACK COAT ON SAWCUT FACE.

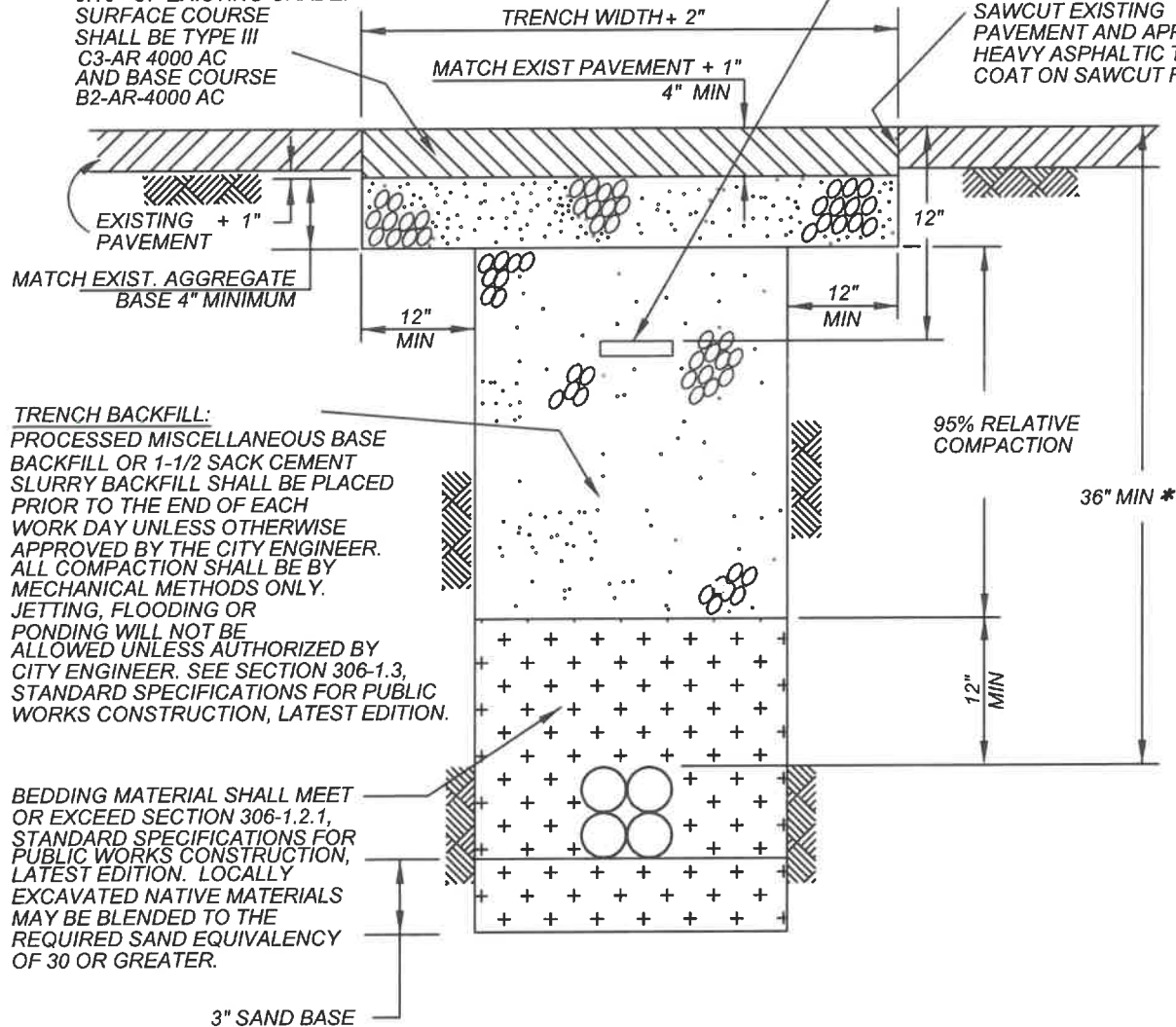

**TRENCH BACKFILL:**  
 PROCESSED MISCELLANEOUS BASE BACKFILL OR 1-1/2 SACK CEMENT SLURRY BACKFILL SHALL BE PLACED PRIOR TO THE END OF EACH WORK DAY UNLESS OTHERWISE APPROVED BY THE CITY ENGINEER. ALL COMPACTION SHALL BE BY MECHANICAL METHODS ONLY. JETTING, FLOODING OR PONDING WILL NOT BE ALLOWED UNLESS AUTHORIZED BY CITY ENGINEER. SEE SECTION 306-1.3, STANDARD SPECIFICATIONS FOR PUBLIC WORKS CONSTRUCTION, LATEST EDITION.

BEDDING MATERIAL SHALL MEET OR EXCEED SECTION 306-1.2.1, STANDARD SPECIFICATIONS FOR PUBLIC WORKS CONSTRUCTION, LATEST EDITION. LOCALLY EXCAVATED NATIVE MATERIALS MAY BE BLENDED TO THE REQUIRED SAND EQUIVALENCY OF 30 OR GREATER.

\* 36" MIN FOR TRUNK AND DISTRIBUTION CONDUIT SYSTEM AND 18" MIN FOR SERVICE LATERAL CONDUIT SYSTEM.

**NOTES:**

- 1.) SEE STD No's MVSI-185A THROUGH MVSI-185D FOR TECHNICAL PROVISIONS OF COMMUNICATIONS FACILITIES.
- 2.) ALL TRENCHING AND BACKFILL SHALL BE DONE IN ACCORDANCE WITH SECTION 306, STANDARD SPECIFICATIONS FOR PUBLIC WORKS CONSTRUCTION, LATEST EDITION.
- 3.) ORANGE INSULATED COPPER CLAD STEEL TRACER WIRE PER KRISTECH SPECIFICATIONS SHEET, OR EQUAL. TRACER WIRE TO BE INSTALLED 2" ABOVE COMMUNICATION CONDUIT PER "THE COMPLETE UTILITY LOCATING SYSTEM SPECIFICATIONS FOR TELECOMMUNICATIONS" BY COPPERHEAD INDUSTRIES, OR EQUIVALENT.

NOT TO SCALE



RECOMMENDED:  
*Henry...* 12/16/21  
 DIVISION MANAGER DATE  
 APPROVED:  
*[Signature]* 2/4/22  
 PUBLIC WORKS DIRECTOR / DATE  
 CITY ENGINEER

**CITY OF MORENO VALLEY**  
 PUBLIC WORKS DEPARTMENT - CAPITAL PROJECTS DIVISION

**COMMUNICATIONS CONDUIT  
 IN PAVEMENT  
 SEPARATE TRENCH DETAIL**

STANDARD PLAN  
**MVSI-181C-1**

SHEET 3 OF 4



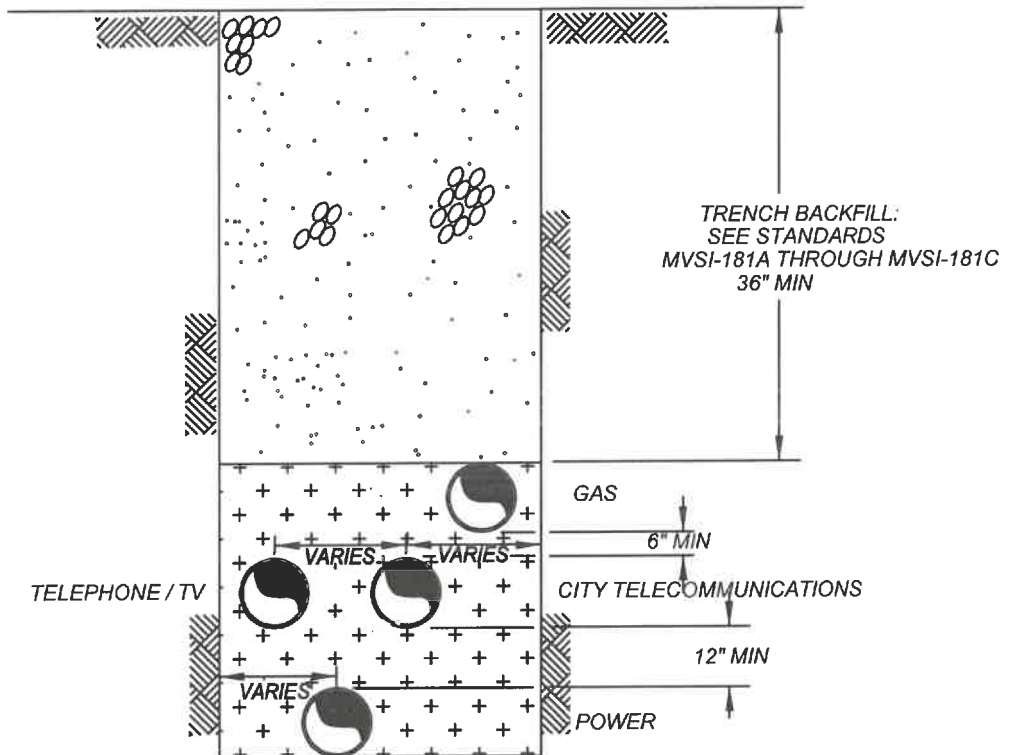

**NOTES:**

- 1.) SEE STD No's MVS-185A THROUGH MVS-185D FOR TECHNICAL PROVISIONS OF TELECOMMUNICATIONS FACILITIES.
- 2.) ORANGE INSULATED COPPER CLAD STEEL TRACER WIRE PER KRISTECH SPECIFICATIONS SHEET, OR EQUAL. TRACER WIRE TO BE INSTALLED 2" ABOVE COMMUNICATION CONDUIT PER "THE COMPLETE UTILITY LOCATING SYSTEM SPECIFICATIONS FOR TELECOMMUNICATIONS" BY COPPERHEAD INDUSTRIES, OR EQUIVALENT.

NOT TO SCALE

	RECOMMENDED: <i>Henry</i> 12/16/21 DIVISION MANAGER DATE	<h2 style="margin: 0;">CITY OF MORENO VALLEY</h2> <p style="margin: 0;">PUBLIC WORKS DEPARTMENT - CAPITAL PROJECTS DIVISION</p>	STANDARD PLAN <h3 style="margin: 0;">MVS-181D-1</h3>
	APPROVED: <i>Shel</i> 2/4/22 PUBLIC WORKS DIRECTOR / DATE CITY ENGINEER	<h3 style="margin: 0;">TYPICAL MULTI-CONDUIT JOINT TRENCH DETAIL</h3>	

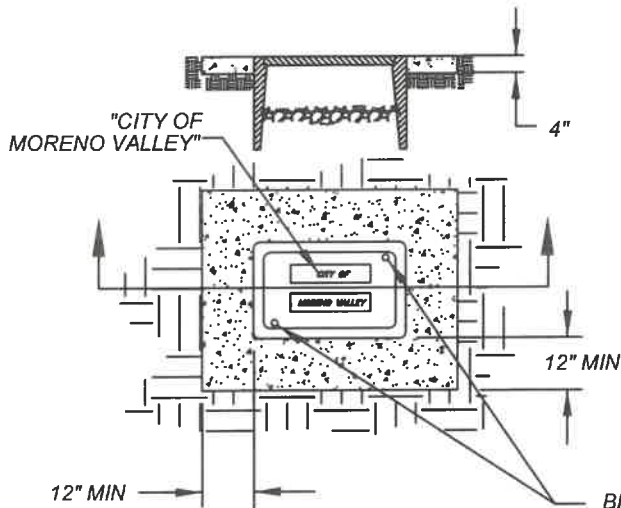
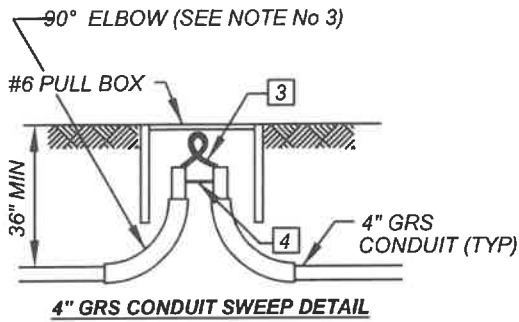

BRASS OR STAINLESS STEEL STUD BOLTS, NUTS AND WASHERS, 2 PER BOX. RECESS IN COVER FOR NUT.

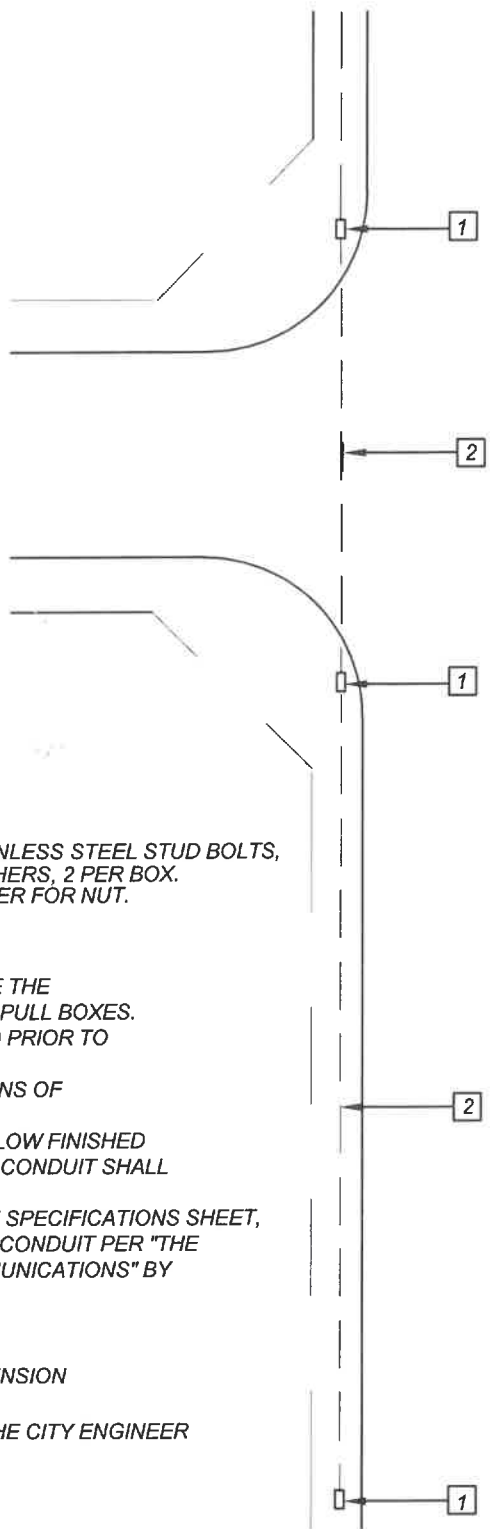

**NOTES:**

- 1.) THE CITY ENGINEER OR DESIGNATED REPRESENTATIVE SHALL APPROVE THE EXACT LOCATION OF ALL GALVANIZED RIGID STEEL CONDUIT (GRS) AND PULL BOXES.
- 2.) THE LOCATION OF GRS CONDUIT AND PULL BOXES WILL BE DETERMINED PRIOR TO SUBMITTAL OF THE ENGINEERING PLANS.
- 3.) SEE STD No's MVS1-185A THROUGH MVS1-185D FOR TECHNICAL PROVISIONS OF TELECOMMUNICATIONS FACILITIES.
- 4.) DISTRIBUTION SYSTEM CONDUIT SHALL BE 2" PVC, SCHEDULE 40, 36" BELOW FINISHED GRADE AND PER STD No MVS1-181D-0 IF APPLICABLE. SERVICE LATERAL CONDUIT SHALL BE 1" PVC, SCHEDULE 40, 18" BELOW FINISHED GRADE.
- 5.) ORANGE INSULATED COPPER CLAD STEEL TRACER WIRE PER KRISTECH SPECIFICATIONS SHEET, OR EQUAL. TRACER WIRE TO BE INSTALLED 2" ABOVE COMMUNICATION CONDUIT PER "THE COMPLETE UTILITY LOCATING SYSTEM SPECIFICATIONS FOR TELECOMMUNICATIONS" BY COPPERHEAD INDUSTRIES, OR EQUIVALENT.

**LEGEND:**

- 1 FURNISH AND INSTALL No 6 PULL BOX (MAX 400' SPACING) & EXTENSION
- 2 FURNISH AND INSTALL NEW 4" GRS CONDUIT, AS APPROVED BY THE CITY ENGINEER OR HIS REPRESENTATIVE.
- 3 LOOP CABLES
- 4 COPPER STRAP FOR GROUND.

NOT TO SCALE



RECOMMENDED:

*Hempig* 12/16/24  
 DIVISION MANAGER DATE

APPROVED:

*[Signature]* 2/4/25  
 PUBLIC WORKS DIRECTOR / DATE  
 CITY ENGINEER

**CITY OF MORENO VALLEY**

PUBLIC WORKS DEPARTMENT - CAPITAL PROJECTS DIVISION

**TELECOMMUNICATIONS  
 TRUNK CONDUIT SYSTEM &  
 PULLBOX LAYOUT DETAIL**

STANDARD PLAN

**MVS1-182-1**

SHEET 1 OF 1

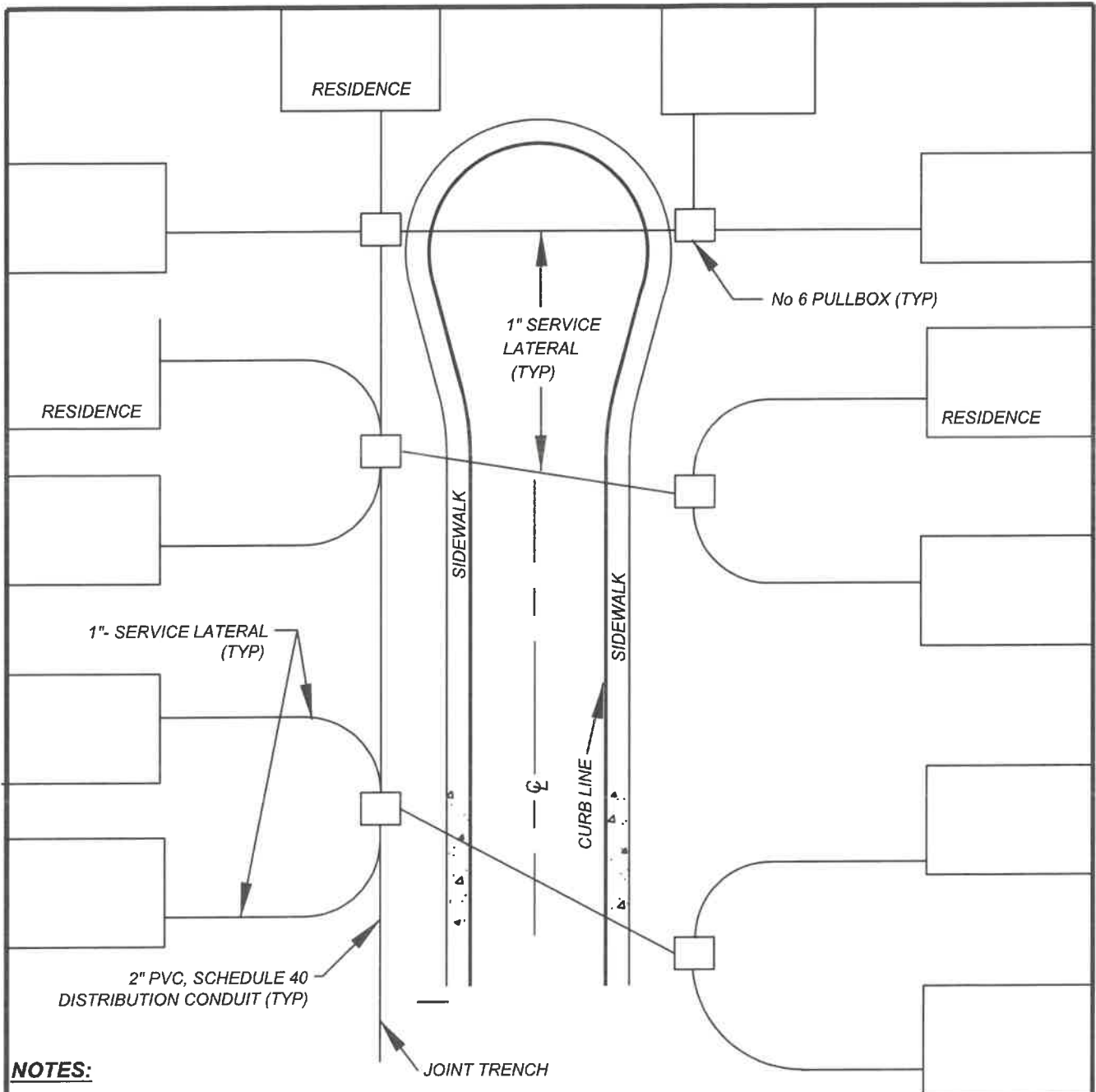

**NOTES:**

- 1.) SEE STD MVS-180A FOR NORMAL LOCATION OF UNDERGROUND UTILITIES.
- 2.) ALL TRENCHING AND BACKFILL SHALL BE DONE IN ACCORDANCE WITH TELECOMMUNICATION STANDARDS FOR TYPE OF SURFACE COVER. SEE TELECOMMUNICATION STDS MVS-181A THROUGH MVS-181D, PAGES 1 THROUGH 4.
- 3.) MAINTAIN MINIMUM 12" FROM ALL TRENCH OCCUPANTS EXCEPT CATV PER CALIFORNIA PUBLIC UTILITY COMMISSION GENERAL ORDER 128.
- 4.) ORANGE INSULATED COPPER CLAD STEEL TRACER WIRE PER KRISTECH SPECIFICATIONS SHEET, OR EQUAL. TRACER WIRE TO BE INSTALLED 2" ABOVE COMMUNICATION CONDUIT PER "THE COMPLETE UTILITY LOCATING SYSTEM SPECIFICATION FOR TELECOMMUNICATIONS" BY COPPERHEAD INDUSTRIES, OR EQUIVALENT.
- 5.) SEE STD MVS-185A THRU MVS-185D FOR TECHNICAL PROVISIONS OF TELECOMMUNICATIONS FACILITIES. NOT TO SCALE

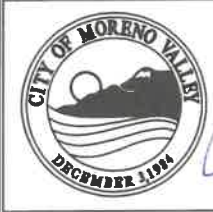

RECOMMENDED:  
*Hempy* 12/16/21  
 DIVISION MANAGER DATE

APPROVED:  
*[Signature]* 2/4/22  
 PUBLIC WORKS DIRECTOR / DATE  
 CITY ENGINEER

**CITY OF MORENO VALLEY**  
 PUBLIC WORKS DEPARTMENT - CAPITAL PROJECTS DIVISION

**TELECOMMUNICATIONS  
 DISTRIBUTION AND SERVICE  
 LATERAL CONDUIT SYSTEM**

STANDARD PLAN  
**MVSI-183-1**  
 SHEET 1 OF 1

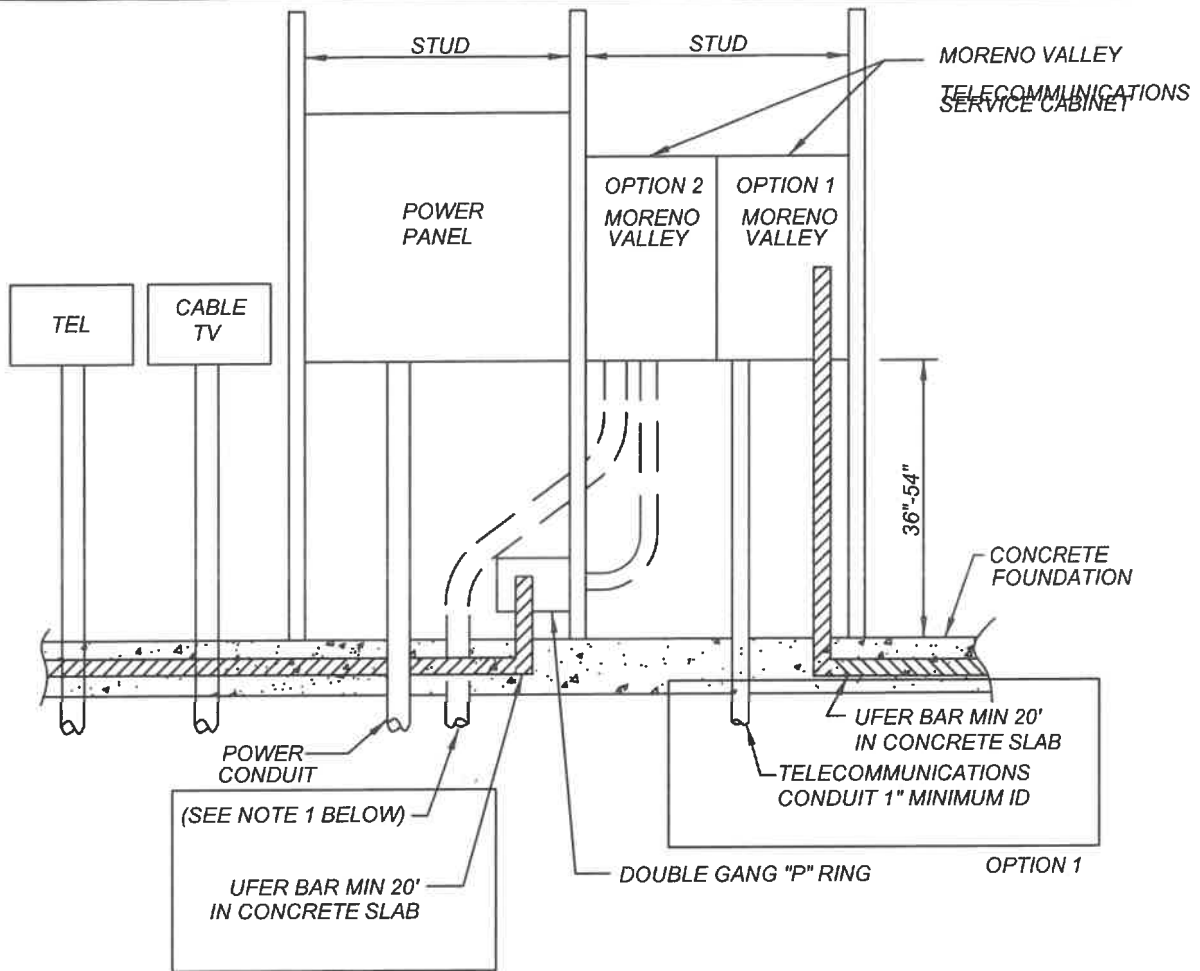

**NOTES:**

- 1.) IF THE TELECOMMUNICATIONS CONDUIT ENTERS THE SAME BAY AS THE POWER CONDUIT (DASHED CONDUIT IN DETAIL ABOVE), SWEEPS MUST BE PLACED BY THE DEVELOPER INTO THE TELECOMMUNICATIONS SERVICE CABINET. CONDUIT SWEEPS MUST BE OF ADEQUATE RADIUS TO ALLOW FOR CABLE PLACEMENT.
- 2.) THE DEVELOPER IS PROVIDED WITH THREE OPTIONS RELATED TO GROUNDING. THE ORDER OF PRIORITY IS AS FOLLOWS.
  - A. UFER BAR EXTENDED INTO TELECOMMUNICATIONS SERVICE CABINET.
  - B. CONDUIT FROM UFER TO TELECOMMUNICATIONS SERVICE CABINET.
  - C. DEVELOPER INSTALLED #12 GROUND WIRE FROM UFER TO TELECOMMUNICATIONS SERVICE CABINET.

THE GROUNDING MEDIUM MUST BE PERMANENTLY ACCESSIBLE BY PLACEMENT OF A DOUBLE GANG "P" RING (3") MOUNTED ON THE BUILDING EXTERIOR.
- 3.) THE MINIMUM DIMENSIONS OF THE MORENO VALLEY TELECOMMUNICATIONS SERVICE CABINET SHOULD BE 8" H x 6" W x 4"D.
- 4.) ORANGE INSULATED COPPER CLAD STEEL TRACER WIRE PER KRISTECH SPECIFICATIONS SHEET, OR EQUAL. TRACER WIRE TO BE INSTALLED 2" ABOVE COMMUNICATION CONDUIT PER "THE COMPLETE UTILITY LOCATING SYSTEM SPECIFICATIONS FOR TELECOMMUNICATIONS" BY COPPERHEAD INDUSTRIES, OR EQUIVALENT.

TELECOMMUNICATIONS STANDARD UNDERGROUND SERVICE ARRANGEMENTS FOR RESIDENTIAL BUILDING (1 TO 2 LIVING UNITS)

NOT TO SCALE

	RECOMMENDED: <i>Henry</i> 12/16/21 DIVISION MANAGER DATE	<h2 style="margin: 0;">CITY OF MORENO VALLEY</h2> <p style="margin: 0;">PUBLIC WORKS DEPARTMENT - CAPITAL PROJECTS DIVISION</p>	STANDARD PLAN <b>MVSI-184A-1</b>
	APPROVED: <i>[Signature]</i> 2/1/22 PUBLIC WORKS DIRECTOR / DATE CITY ENGINEER	<h3 style="margin: 0;">TELECOMMUNICATIONS RESIDENTIAL UNITS</h3>	SHEET 1 OF 2



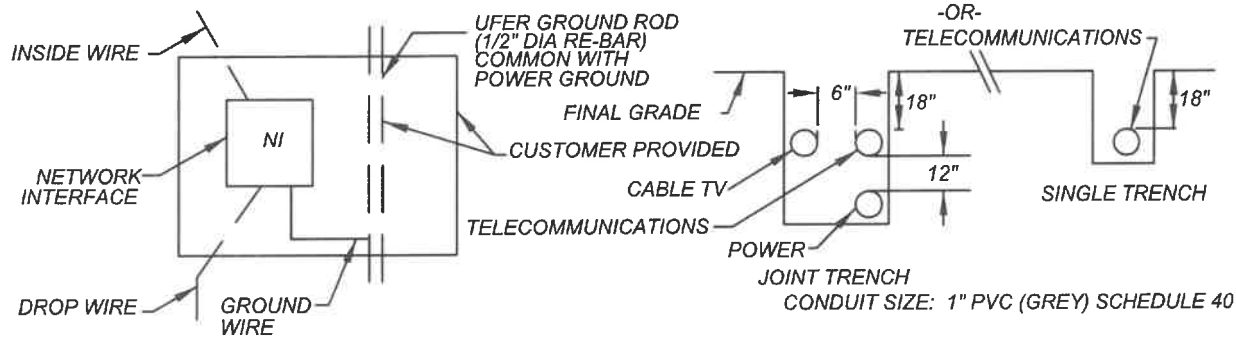
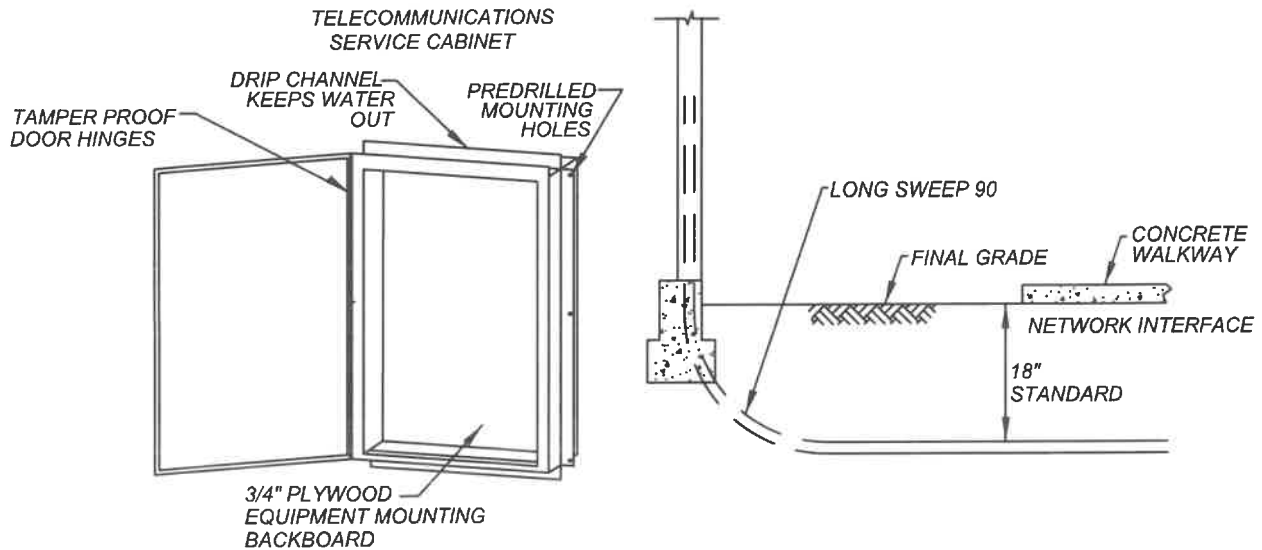

**TYPICAL CABINET LAYOUT**

**WEATHERPROOF EXTERIOR MOUNTING NOTES:**

- 1.) SAFE ALL - METAL CONSTRUCTION - METAL CONSTRUCTION PERMITS COMMON GROUND FOR ALL INSTALLATIONS. ALL METAL PARTS ARE PROTECTED WITH SPECIAL EARTH-TONE POLYURETHANE COVERING.
- 2.) STANDARD CONSTRUCTION REQUIREMENTS - THE TELECOMMUNICATIONS SERVICE CABINET IS PROVIDED FOR MOUNTING ON 2" x 4" STUDS ON 16" CENTER ON THE OUTSIDE BUILDING WALL. THE BOTTOM OF THE CABINET SHOULD BE 36" - 59" ABOVE FINAL GRADE.
- 3.) BURIED SERVICE - PROVIDE AN ENTRANCE CONDUIT STUBBED THROUGH THE FOUNDATION.
- 4.) SPECIFICATIONS - TELECOMMUNICATIONS SERVICE CABINET WITH GALVANIZED STEEL FINISH HAS MINIMUM DIMENSIONS OF 8" H x 6" W x 4" D.
- 5.) ORANGE INSULATED COPPER CLAD STEEL TRACER WIRE PER KRISTECH SPECIFICATIONS SHEET, OR EQUAL. TRACER WIRE TO BE INSTALLED 2" ABOVE COMMUNICATION CONDUIT PER "THE COMPLETE UTILITY LOCATING SYSTEM SPECIFICATIONS FOR TELECOMMUNICATIONS" BY COPPERHEAD INDUSTRIES, OR EQUIVALENT.

NOT TO SCALE

	RECOMMENDED: <i>[Signature]</i> 12/16/21 DIVISION MANAGER      DATE	<h2 style="margin: 0;">CITY OF MORENO VALLEY</h2> <p style="margin: 0;">PUBLIC WORKS DEPARTMENT - CAPITAL PROJECTS DIVISION</p>	
	APPROVED: <i>[Signature]</i> 2/4/22 PUBLIC WORKS DIRECTOR / DATE CITY ENGINEER	<h3 style="margin: 0;">TELECOMMUNICATIONS RESIDENTIAL UNITS</h3>	STANDARD PLAN <h3 style="margin: 0;">MVSI-184B-1</h3> <p style="margin: 0;">SHEET 2 OF 2</p>

**TECHNICAL PROVISIONS FOR  
INSTALLATION OF UNDERGROUND CONDUIT AND RELATED FACILITIES  
FOR THE TELECOMMUNICATION CONDUIT SYSTEM  
IN THE CITY OF MORENO VALLEY, CALIFORNIA**

**GENERAL DESCRIPTION OF REQUIREMENTS**

All new telecommunication plant installations serving new or existing single-family residential, multi-family residential, mobile homes, and commercial property within the boundaries of the City of Moreno Valley ("City"), shall be provided with underground conduit, pull boxes, pull lines, and all related items ("the conduit system"), as more fully described below, as well as telecommunication system trunk and/or distribution fiber optic cables, and related facilities.

Installation of said facilities shall be coordinated with all cable television companies and utilities (i.e., electric power, telephone service, gas, etc.), which will provide their services via underground facilities within the same development area. Conduits shall typically be placed in a shared trench with telephone and cable television conduits. Prior to any physical installation of facilities, including but not limited to digging and/or trenching, all applicable City permits must be secured. Underground Service Alert of Southern California ("USA"), or its successor(s), must be properly notified by the excavator prior to the start of the actual excavation.

The City reserves the right, particularly in locations where other City improvements exist, to require that conduits be installed by jacking the conduit, in accordance with Section 306-8, "Microtunneling," of the latest edition of the Standard Specifications for Public Works Construction (Green book).

The conduit system shall generally consist of trunk and distribution conduits installed between and swept into pull boxes mounted at finished grade. Service laterals to locations designated by the City shall emanate from the trunk and/or distribution pull boxes and then terminate at the service location.

All underground conduit and facilities shall be installed to provide for continuous and sealed runs between pull boxes so as to retard the ingress into the conduit system of liquids and/or other foreign materials.

The installation of the conduit system shall be constructed in strict conformance and compliance with all federal, state, and local requirements, and specifically the requirements of the State of California Public Utilities Commission General Order 95 and General Order 128, as amended. Should General Order 95 and/or General Order 128 become null, void, or otherwise be declared unenforceable in whole or in part by court or legislative action, then the requirements of the American National Standards Institute shall apply in place of General Order 95 and/or General Order 128 to the extent that General Order 95 and/or General Order 128 are unenforceable. The City specifically reserves the right to modify, extend in scope, or reduce in scope specific construction requirements, which in the opinion of the City Engineer, are necessary to protect the public.

Testing shall conform to the provisions in Section 86-2.05C, "Installation," of the latest edition of the Caltrans Standard Specifications and these Technical Provisions. The Contractor is responsible for all costs involved in testing the conduit system. Backfill material shall not be placed until the conduit system has been inspected and approved for backfilling by the Engineer.

NOT TO SCALE

	RECOMMENDED: <i>Henry Jones</i> 12/16/21 DIVISION MANAGER DATE	<b>CITY OF MORENO VALLEY</b> PUBLIC WORKS DEPARTMENT - CAPITAL PROJECTS DIVISION	
	APPROVED: <i>[Signature]</i> 2/4/22 PUBLIC WORKS DIRECTOR / DATE CITY ENGINEER	<b>TELECOMMUNICATIONS TECHNICAL PROVISIONS</b>	

**SECTION A  
CONDUIT SIZE, TYPE, COVER, AND LOCATION  
TRUNK, DISTRIBUTION, AND SERVICE LATERAL CONDUIT SYSTEM**

Within the City of Moreno Valley right-of-way and public utility easements, the following construction standards shall apply to the construction of the trunk conduit system:

**A-1.** All conduit runs and related facilities (e.g., pull boxes, etc.) shall be plotted and shown on drawings which shall be filed with, and approved by the City Engineer prior to the installation of the conduit system. No change in location of the conduit system shall be made prior to, or at the time of physical installation, unless authorized in writing in advance by the City Engineer. After completion of installation, all conduit runs and related facilities shall be accurately plotted as installed on the As-Built Drawings. Location measurements shall be made from the curb face (or from the centerline of the road if no curb exists), and shall be shown on the As-Built Drawings, which shall be filed with the City Engineer within thirty days after conduit installation. As-Built Drawings shall be 1"=50' scale on 24"x36" Mylar sheets and shall include details and general notes.

**A-2.** A polypropylene, polyethylene, nylon, or other City approved non-organic type pull line shall be installed into the conduit. Pull lines shall have a breaking strength of no less than five hundred (500) pounds. Pull lines shall extend no less than three feet (3') beyond each end of the conduit. Each terminus of the conduit run shall be secured with a City-approved conduit end plug/cap in such a way as to retard the ingress into the conduit system of liquids and/or other foreign materials.

**A-3.** Conduit system pull boxes shall be no smaller than Caltrans Standard Plan No. 6 pull boxes. Pull box lid shall be labeled "City of Moreno Valley." All pull box lids shall be secured with two brass or stainless steel tamper-proof stud bolts, nuts, and washers per Standard No. C.

**A-4.** Each pull box shall be placed as to intercept and break continuous straight conduit runs at intervals of no more than four hundred feet (400'), with two (2) 90 degree (90°) wide sweeps, each with a minimum radius of not less than six times the inside diameter of the conduit, into pull boxes at each end of the conduit run. In the event that conduit installation necessitates the installation of additional sweeps between pull boxes, a pull box shall be placed after every 360 degrees (360°) (cumulative in any direction) of sweep, including the sweeps into and out of pull boxes. A copper tie strap between all conduits shall ground all conduits within pullboxes.

**A-5.** Pull boxes shall typically be placed in parkway areas behind the sidewalk. Pull boxes may be placed in roads or other traffic areas only upon approval by the City Engineer, and shall have a traffic bearing concrete body and lid. Pull boxes shall not be installed in sidewalk areas or in driveways unless otherwise authorized in writing by the City Engineer. All lids shall be permanently marked with the inscription "City of Moreno Valley." All lids shall have an integral system to secure the lid to the main body of the vault.

NOT TO SCALE

	RECOMMENDED: <i>Henry</i> 12/16/21 DIVISION MANAGER      DATE	<b>CITY OF MORENO VALLEY</b> PUBLIC WORKS DEPARTMENT - CAPITAL PROJECTS DIVISION	
	APPROVED: <i>[Signature]</i> 2/4/22 PUBLIC WORKS DIRECTOR / DATE CITY ENGINEER	<b>TELECOMMUNICATIONS TECHNICAL PROVISIONS</b>	
			SHEET 2 OF 4

**SECTION B  
CONDUIT SIZE, TYPE, COVER, AND LOCATION  
TRUNK CONDUIT SYSTEM**

Within the City of Moreno Valley right-of-way and public utility easements, the following construction standards shall apply to the construction of the trunk conduit system:

**B-1.** Polyvinyl chloride (PVC), Schedule 40, shall be furnished and installed in continuous runs. Conduit size shall be no smaller than four inches (4") in diameter. Trunk conduit system shall be installed on all arterial streets. Trunk conduit may also be installed on designated collector streets at the direction of the City Engineer. Orange warning tape shall be installed directly above trunk conduit and 12 inches (12") below finished grade, per Standard No. A.

**B-2.** Trunk conduit shall be placed underground so as to provide for a minimum cover of 36 inches (36") below finished grade as measured from the top of the conduit. Backfill requirements shall be per City Standard Plan No. A and may be modified by the City Engineer.

**SECTION C  
CONDUIT SIZE, TYPE, COVER, AND LOCATION  
DISTRIBUTION AND SERVICE LATERAL CONDUIT SYSTEM**

Within the City of Moreno Valley, the following construction standards shall apply to the construction of the distribution and service lateral conduit system that originate at trunk conduit system pull boxes.

**C-1.** Polyvinyl chloride (PVC), Schedule 40, conduit shall be furnished and installed in continuous runs. The distribution conduit size shall be two inches (2") in diameter. Service lateral conduit shall be one inch (1") PVC, Schedule 40. Service laterals that exceed two hundred fifty feet (250') in length shall be two inch (2") PVC, Schedule 40. The minimum strength of the service entry conduits through foundations shall be equal to, or greater than PVC, Schedule 40. Conduit shall be laid, connected, and solvent welded in continuous runs. "Bell" type overlapping ends of no less than one inch (1"), or slip couplets shall be used to join sections of conduit. Manufacturer's instructions shall be followed in solvent welding conduit sections so as to prevent ingress into the conduit system of liquids and/or other foreign materials. PVC conduit shall be assembled together so that the manufacturer's identification markings are facing up and readable from the top of the trench. Orange warning tape shall be installed directly above distribution conduit and 12 inches (12") below finished grade, per Standard No. MVSI-185C. Orange insulated copper clad steel tracer wire per Kristech specifications sheet, or equal. Tracer wire to be installed 2" above communications conduit per "The Complete Utility Locating System Specifications for Telecommunications" by Copperhead Industries, or equivalent.

**C-2.** Distribution conduit shall be placed underground so as to provide for a minimum cover of 36 inches (36") below finished grade as measured from the top of the conduit. Service lateral conduit shall be placed underground so as to provide for a minimum cover of 18 inches (18") below finished grade as measured from the top of the conduit. Where service lateral conduit crosses public roadway, minimum cover shall be 36 inches (36") below finished grade. Backfill requirements shall be per City Standard Plan No. A, and may be modified by the City Engineer.

NOT TO SCALE

	RECOMMENDED: <i>Henrygo</i> 12/16/21 DIVISION MANAGER      DATE	<b>CITY OF MORENO VALLEY</b> PUBLIC WORKS DEPARTMENT - CAPITAL PROJECTS DIVISION	
	APPROVED: <i>[Signature]</i> 2/4/22 PUBLIC WORKS DIRECTOR / DATE CITY ENGINEER	<b>TELECOMMUNICATIONS TECHNICAL PROVISIONS</b>	



**C-3.** At each designated service location, the service lateral conduit system shall extend through the foundation to the rear of a Service Inlet Box co-located in the common utility service area at the service location. It is the policy of the City to co-locate all service entries into a structure.

**C-4.** A Service Inlet Box ("service box") shall be placed at the terminus of each service lateral per Standard No. E. The service box shall be designed to be secured to studs on 16" centers. The finish shall be galvanized steel.

**C-5.** Service box lids shall be permanently marked with the inscription "City of Moreno Valley," or any other inscription that is authorized in writing in advance by the City Engineer. Lids shall have an integral device to secure the lid to the main body of the service box.

**C-6.** A service trench must be provided from the property line to the riser protection conduit. It may be a joint trench for use by several utilities, or a single trench for telecommunications facilities only. Riser protection conduit may be any standard electrical trade conduit except aluminum or flexible steel. Access to the point of connection to the grounding medium must be permanently concealed in walls that are to be finished on both the exterior and interior surfaces.

### SECTION D FIBER OPTIC CABLE SPECIFICATIONS

**D-1.** Fiber Optic Cable shall be 144 strand single mode fiber Corning brand, or equal, with optical characteristics as specified below.

Fiber Code	E
Fiber Name	Single-mode (OS2)
Fiber Type	Single-mode
Performance Option Code	00
Maximum Attenuation	0.35 dB/km / 0.35 dB/km / 0.25dB/km
Wavelengths	1310 nm / 1383 nm / 1550 nm
Fiber Category	G.652.D

NOT TO SCALE

	RECOMMENDED: <i>Henry</i> 12/16/21 DIVISION MANAGER      DATE	<b>CITY OF MORENO VALLEY</b> PUBLIC WORKS DEPARTMENT - CAPITAL PROJECTS DIVISION	
	APPROVED: <i>[Signature]</i> 2/4/22 PUBLIC WORKS DIRECTOR / DATE CITY ENGINEER	<b>TELECOMMUNICATIONS TECHNICAL PROVISIONS</b>	

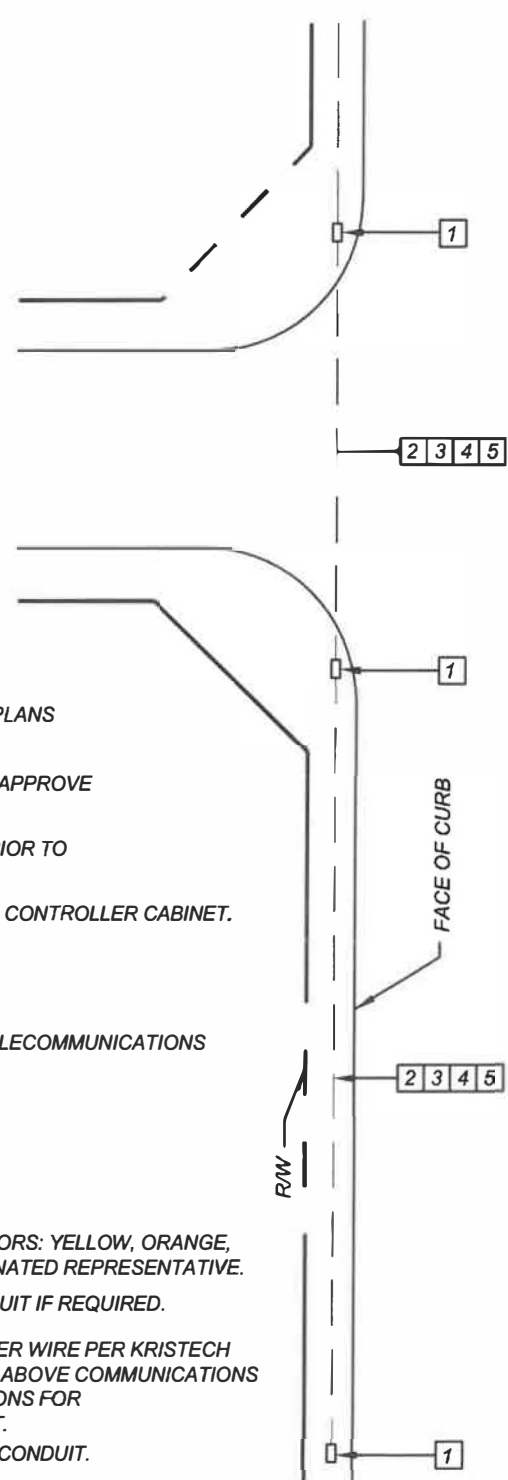

**NOTES:**

- 1.) ALL WORK AND MATERIALS SHALL CONFORM TO CALTRANS STANDARD PLANS AND SPECIFICATIONS.
- 2.) THE CITY TRAFFIC ENGINEER OR DESIGNATED REPRESENTATIVE SHALL APPROVE THE EXACT LOCATION OF ALL CONDUITS AND PULL BOXES.
- 3.) THE LOCATION OF CONDUITS AND PULL BOXES WILL BE DETERMINED PRIOR TO SUBMITTAL OF THE ENGINEERING PLANS.
- 4.) INTERCONNECT SHALL NOT BE SPLICED EXCEPT IN THE TRAFFIC SIGNAL CONTROLLER CABINET.
- 5.) CONDUIT SHALL BE INSTALLED UNDER SIDEWALK WHERE APPLICABLE.
- 6.) SEE STDS MVSİ-181A AND MVSİ-181B FOR TRENCH DETAIL.
- 7.) SEE STD MVSİ-185A THRU MVSİ-185D FOR TECHNICAL PROVISIONS OF TELECOMMUNICATIONS FACILITIES.

**LEGEND:**

- 1 FURNISH AND INSTALL P48 FIBERGLASS PULL BOX @ 600' SPACING.
- 2 FURNISH AND INSTALL FOUR (4) 1.5" HDPE SCHEDULE 80 CONDUITS (COLORS: YELLOW, ORANGE, BLUE, AND BLACK) AS APPROVED BY CITY TRAFFIC ENGINEER OR DESIGNATED REPRESENTATIVE.
- 3 FURNISH AND INSTALL 6 PAIR No 19 INTERCONNECT CABLE IN ONE CONDUIT IF REQUIRED.
- 4 FURNISH AND INSTALL ORANGE INSULATED COPPER CLAD STEEL TRACER WIRE PER KRISTECH SPECIFICATIONS SHEET, OR EQUAL. TRACER WIRE TO BE INSTALLED 2" ABOVE COMMUNICATIONS CONDUIT PER "THE COMPLETE UTILITY LOCATING SYSTEM SPECIFICATIONS FOR TELECOMMUNICATIONS" BY COPPERHEAD INDUSTRIES, OR EQUIVALENT.
- 5 FURNISH AND INSTALL MULE TAPE (TENSILE STRENGTH 1250LBS) IN EACH CONDUIT. SECURE MULE TAPE IN EACH TERMINATING PULLBOX.

NOT TO SCALE

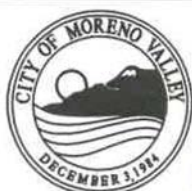

RECOMMENDED:  
*We. Sw* 2/1/2022  
 DIVISION MANAGER DATE  
 APPROVED:  
*[Signature]* 2/4/22  
 PUBLIC WORKS DIRECTOR / DATE  
 CITY ENGINEER

**CITY OF MORENO VALLEY**  
 PUBLIC WORKS DEPARTMENT - TRANSPORTATION ENGINEERING DIVISION

**CITYWIDE COMMUNICATION CONDUITS**

STANDARD PLAN  
**MVSİ-186-1**  
 SHEET 1 OF 1

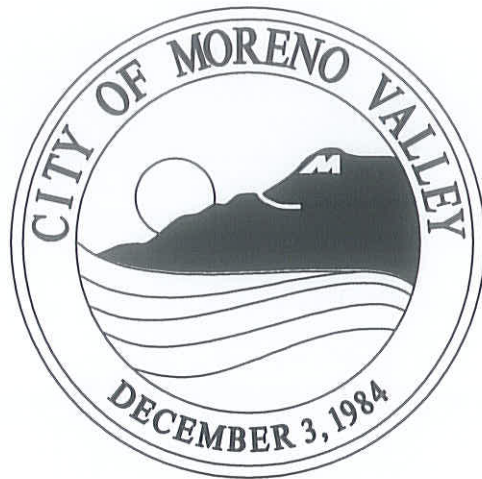

# **CITY OF MORENO VALLEY STANDARD PLANS**

## **SECTION 2**

# **SEWERS AND SANITATION**

*Note: All Eastern Municipal Water District Standards  
are adopted in this Section.*

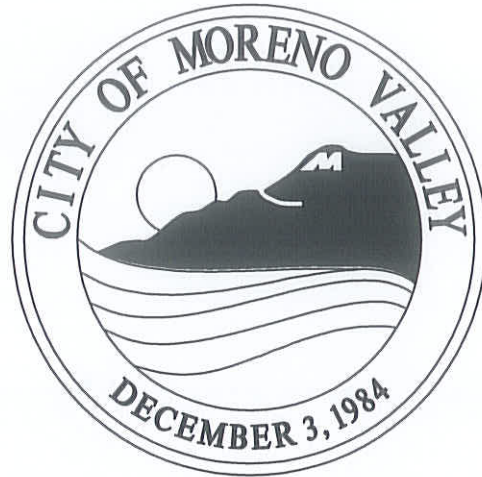

# **CITY OF MORENO VALLEY STANDARD PLANS**

## **SECTION 3**

# **FLOOD AND EROSION CONTROL**

*Note: All other Riverside County Flood Control and Water Conservation District Standards not specifically included, are adopted in this Section. The use of APWA's Flood Control and Storm Drain Facilities Standards must have prior approval from the Public Works Director/City Engineer.*



# City of Moreno Valley

## Standard Plans Index - 2017 Edition

---

### **SECTION 2: Sewers and Sanitation**

**Note:** *All Eastern Municipal Water District Standards are adopted in this Section.*

### **SECTION 3: Flood and Erosion Control**

#### General

MVFE-300A-0	Catch Basin
MVFE-300B-0	Catch Basin Notes
MVFE-300C-0	Catch Basin Opening Detail
MVFE-300D-0	Catch Basin Face Plate and Protection Bar Detail
MVFE-300E-0	Catch Basin Manhole Frame and Cover
MVFE-300F-0	Catch Basin Reinforcement

#### Manholes and Structures

MVFE-320A-0	Manhole
MVFE-320B-0	Manhole Notes
MVFE-320C-0	Manhole Shaft for Cast Pipe
MVFE-321A-0	Manhole Frame and Cover
MVFE-321B-0	Manhole Frame and Cover Notes
MVFE-340-0	Concrete Collar for Pipe 24 through 36 Inches

#### Water Quality and Erosion Control

MVFE-350-0	NPDES Notes
MVFE-351A-0	Erosion Control Notes (Rough Grading Phase)
MVFE-351B-0	Erosion Control Notes (Precise Grading Phase)
MVFE-351C-0	Erosion Control Notes (Straw-Bale Barriers)
MVFE-351D-0	Erosion Control Notes
MVFE-351E-0	Construction Driveway Desilting Basin
MVFE-351F-0	Temporary Access Ramp and Check Dam Detail
MVFE-352-0	Semi-Pervious Straw Bale Sediment Barrier
MVFE-353-0	Temporary Desilting Measures at Catch Basin
MVFE-354-0	Stabilized Construction Exit Sediment Removal
MVFE-355-0	Silt Fence Detail
MVFE-356-0	Desilting Basin

**Note:** *All other Riverside County Flood Control and Water Conservation District Standards which are not specifically included are adopted in this Section. The use of APWA's Flood Control and Storm Drain Facilities Standards must have prior approval from the Public Works Director/City Engineer.*

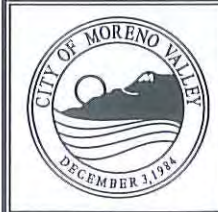
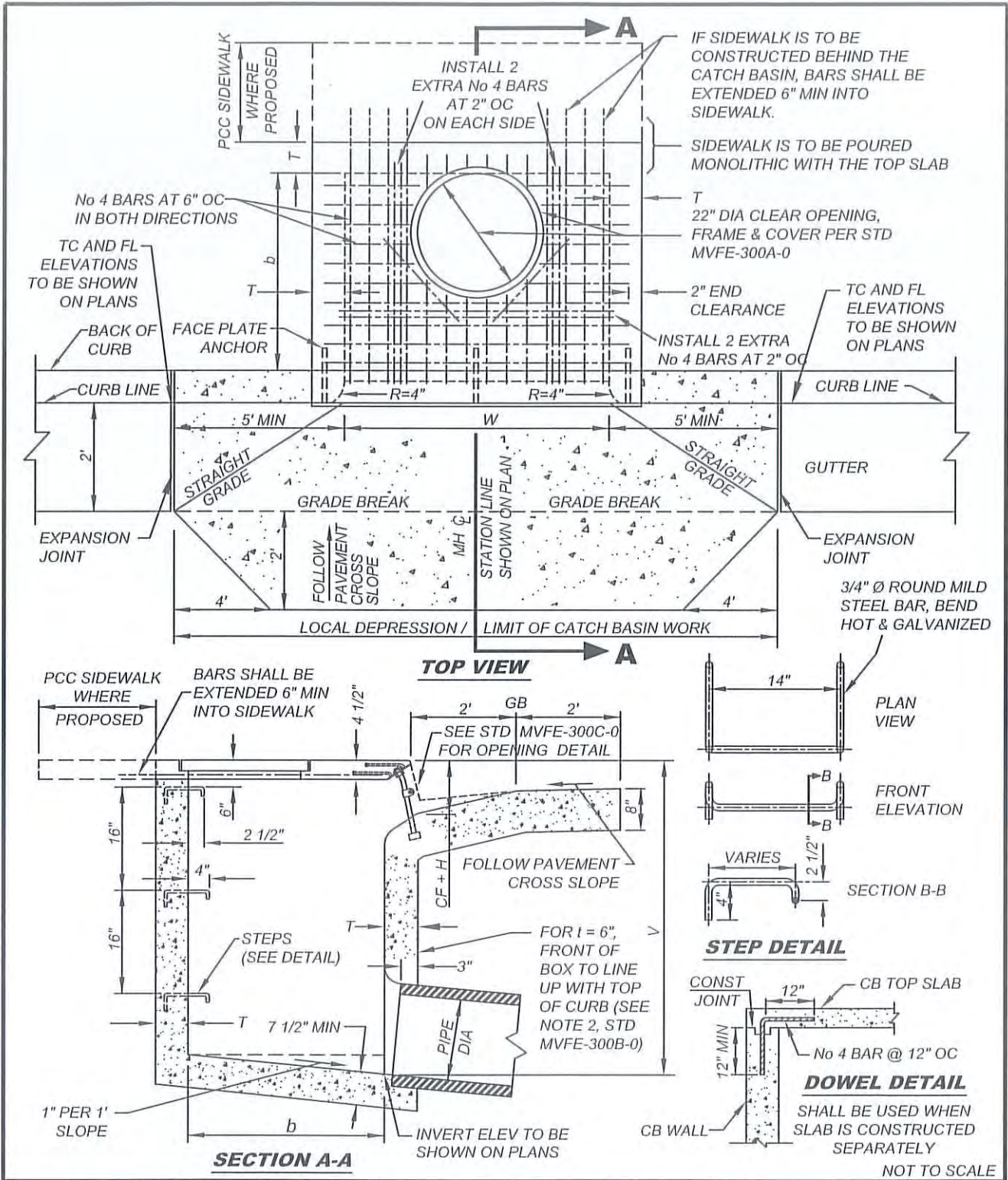

RECOMMENDED:  
 [Signature] / 1/21/14  
 DIVISION MANAGER DATE  
 APPROVED:  
 [Signature] / 1/29/14  
 PUBLIC WORKS DIRECTOR / DATE  
 CITY ENGINEER

**CITY OF MORENO VALLEY**  
 PUBLIC WORKS DEPARTMENT - CAPITAL PROJECTS DIVISION

**CATCH BASIN**

STANDARD PLAN  
**MVFE-300A-0**



SHEET 1 OF 6



**NOTES:**

- 1) CONCRETE SHALL BE CLASS 560-C-3250 PCC, CURED WITH WHITE PIGMENTED CURING COMPOUND.
- 2) DIMENSIONS:
  - a. W SHALL BE AS SPECIFIED ON THE PLAN (4' MIN).
  - b. V SHALL BE AS SPECIFIED ON THE PLAN.
  - c. H = 4" UNLESS OTHERWISE SPECIFIED ON THE PLAN.
  - d. b = 38" UNLESS OTHERWISE SPECIFIED ON THE PLAN.
  - e. T = 6" IF V IS 4' OR LESS. T = 8" IF V IS BETWEEN 4' AND 8'. T = 10" IF V IS 8' OR MORE.
  - f. THICKNESS OF THE WALL UNDER THE OPENING SHALL BE T + 2" WHEN W EXCEEDS 7'-0". IF T > 6", WIDENING OF WALL SHALL BE ON THE STREET SIDE.
- 3) PROTECTION BAR:
  - a. PROTECTION BAR SHALL BE PER STD MVFE-300D-0.
  - b. ALL BARS SHALL BE 1" Ø GALVANIZED SMOOTH STEEL. BAR LENGTHS SHALL NOT EXCEED 21' AND SHALL BE CUT TO FIT IN FIELD.
  - c. WHEN "W" IS OVER 21', PROTECTION BAR SHALL CONSIST OF TWO OR MORE SECTIONS DEPENDING UPON LENGTH OF BASIN.
  - d. INSTALL COUPLING AT DOWNSTREAM END OF CATCH BASIN OPENING.
  - e. PROTECTION BAR "S" SHALL BE INSTALLED WHEN THE MINIMUM CLEAR OPENING OF THE CATCH BASIN EXCEEDS 6". BAR "S" SHALL BE PLACED SUCH THAT NO MINIMUM CLEAR OPENING EXCEEDS 6".
  - f. WHEN ONE BAR IS REQUIRED, "S" SHALL BE 6 3/4". HOWEVER, THIS SHALL BE REDUCED IF NECESSARY SO THAT THE CENTER OF THE PROTECTION BAR IS NOT LESS THAN 2 1/2" FROM THE FACE PLATE.
  - g. WHEN TWO OR MORE BARS ARE REQUIRED, "S" SHALL BE 6 3/4" WITH REMAINING BARS SPACED AT 6 3/4" CC. SPACING OF TOP BAR SHALL BE REDUCED IF NECESSARY SO THAT THE CENTER OF THE BAR IS NOT LESS THAN 2 1/2" FROM THE FACE PLATE.
- 4) SUPPORT BOLT:
  - a. SUPPORT BOLTS SHALL BE PER STD MVFE-300C-0.
  - b. SUPPORT BOLTS ARE REQUIRED WHEN LENGTH OF THE CATCH BASIN IS 7' OR GREATER.
  - c. LOCATION OF SPECIAL SUPPORT BARS AND ADDITIONAL SOCKET SET SCREWS SHALL BE DETERMINED BY THE ENGINEER IN THE FIELD.
  - d. SOCKET SET SCREW SHALL BE STAINLESS STEEL OR BRASS.
- 5) FACE PLATE ASSEMBLY:
  - a. FACE PLATE SHALL BE PER STD MVFE-300D-0.
  - b. LENGTH OF FACE PLATE SHALL BE "W" + 12" EXCEPT AS MODIFIED FOR CURB OPENING CATCH BASIN AT DRIVEWAY.
  - c. WHERE CATCH BASIN IS TO BE CONSTRUCTED ON CURVE, THE MAXIMUM CHORD LENGTH FOR FACE PLATE SHALL BE SUCH THAT THE MAXIMUM DIMENSION FROM SAID CHORD (MEASURED PERPENDICULAR THERETO) TO THE TRUE CURVE WILL NOT EXCEED ONE INCH. WHERE MORE THAN ONE CHORD IS REQUIRED, CHORD LENGTHS SHALL BE EQUAL.
  - d. WHERE LENGTH OF FACE PLATE IS BETWEEN 22' AND 43', TWO SECTIONS MAY BE USED. WHEN LENGTH EXCEEDS 43', THREE SECTIONS MAY BE USED. SECTIONS SHALL BE SPLICED ACCORDING TO THE SPLICE DETAIL PER STD MVFE-300D-0. SPLICE SHALL BE PLACED ONE FOOT FROM SUPPORT BOLT.
  - e. SET END ANCHORS 3" FROM ENDS OF FACE PLATE.
  - f. PLACE ONE ANCHOR AT EACH SIDE OF ANY OR ALL SPLICE JOINTS AND WITHIN 6" THEREOF.
  - g. ROUND HEAD ANCHORS FOR FACE PLATE SHALL BE NELSON H-4F SHEAR CONNECTOR, KSN WELDING SYSTEMS DIVISION SHEAR CONNECTOR OR EQUAL.
- 6) CONNECTOR PIPE: UNLESS OTHERWISE INDICATED ON THE PROJECT PLANS, CONNECTOR PIPE SHALL BE 24" ID MINIMUM, REINFORCED CONCRETE PIPE (RCP).
- 7) STEPS: SHALL BE PER STD MVFE-300A-0 AND SHALL BE 3/4" Ø ROUND MILD STEEL BAR, BEND HOT & GALVANIZED. STEPS SHALL BE INSTALLED 16" APART WHEN V EXCEED 4 1/2'. THE TOP STEP SHALL BE 6" BELOW THE TOP SURFACE AND SHALL BE 2 1/2" CLEAR FROM THE WALL. ALL OTHER STEPS SHALL BE 4" CLEAR FROM THE WALL. ONLY ONE STEP 12" FROM THE BOTTOM FLOOR SHALL BE INSTALLED IF V IS 4 1/2' OR LESS. ALL STEPS SHALL BE ANCHORED NOT LESS THAN 4" INTO THE CATCH BASIN WALL. IF STEPS ARE NOT WET SET / INSTALLED, HIGH-STRENGTH EPOXY ANCHORING ADHESIVE, TYPE SET-XP BY STRONG-TIES OR EQUAL APPROVED, SHALL BE USED FOR THE INSTALLATION.
- 8) STEEL REINFORCEMENT: SHALL BE PER STD MVFE-300F-0.
- 9) MANHOLE FRAME AND COVER: SHALL BE PER STD MVFE-300E-0.
- 10) WHERE THE STRUCTURE IS TO BE CONSTRUCTED WITHIN THE LIMITS OF A PROPOSED SIDEWALK OR IS CONTIGUOUS TO SUCH A SIDEWALK THE TOP SLAB OF THE STRUCTURE SHALL BE Poured MONOLITHIC WITH THE SIDEWALK (WITH NO WEAKENED PLANE JOINT IN BETWEEN). THE SIDEWALK SHALL BE PROVIDED WITH A WEAKENED PLANE JOINT OR A ONE INCH DEEP SAWCUT CONTINUOUSLY ON BOTH SIDES OF THE STRUCTURE WALLS, INCLUDING ACROSS THE FULL WIDTH OF THE SIDEWALK.
- 11) THE SURFACE OF ALL EXPOSED CONCRETE SHALL CONFORM IN SLOPE, GRADE, COLOR, FINISH AND SCORING TO EXISTING OR PROPOSED CURB, GUTTER AND WALK ADJACENT TO THE STRUCTURE. CURVATURE OF CONCRETE SURFACE SHALL BE SHAPED BY CURVED FORMS AND SHALL NOT BE SHAPED BY PLASTERING. FLOOR OF STRUCTURE SHALL BE GIVEN A STEEL TROWELLED FINISH.
- 12) DOWELS SHALL BE REQUIRED PER DETAIL SHOWN ON STD MVFE-300A-0 WHEN THE TOP SLAB IS CONSTRUCTED SEPARATELY.
- 13) STENCIL INLET STRUCTURE WITH "ONLY RAIN IN THE STORM DRAIN".

NOT TO SCALE

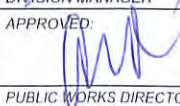
	RECOMMENDED:  DIVISION MANAGER	1/21/14 DATE	<h2 style="margin: 0;">CITY OF MORENO VALLEY</h2> <p style="margin: 0;">PUBLIC WORKS DEPARTMENT - CAPITAL PROJECTS DIVISION</p>		
	APPROVED:  PUBLIC WORKS DIRECTOR / CITY ENGINEER	1/29/14 DATE	<h3 style="margin: 0;">CATCH BASIN NOTES</h3>	STANDARD PLAN <h3 style="margin: 0;">MVFE-300B-0</h3>	
				SHEET 2 OF 6	



3 - #4 BARS x ( W + 6" ) IN  
ADDITION TO REINFORCING  
STEEL PER STDS MVFE-300A-0 &  
MVFE-300F-0 OR AS DETAILED  
ON PLANS

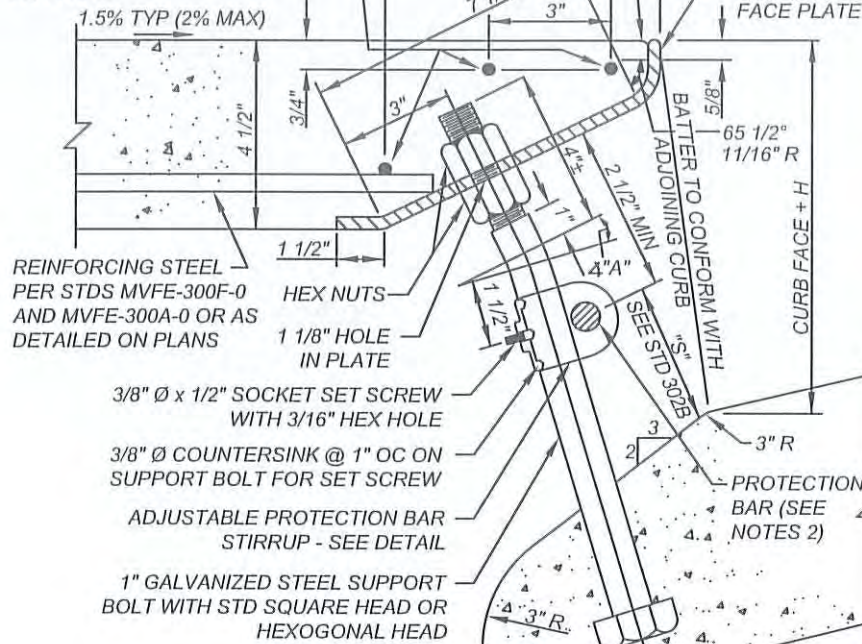

REINFORCING STEEL  
PER STDS MVFE-300F-0  
AND MVFE-300A-0 OR AS  
DETAILED ON PLANS

HEX NUTS  
1 1/8" HOLE  
IN PLATE

3/8" Ø x 1/2" SOCKET SET SCREW  
WITH 3/16" HEX HOLE

3/8" Ø COUNTERSINK @ 1" OC ON  
SUPPORT BOLT FOR SET SCREW

ADJUSTABLE PROTECTION BAR  
STIRRUP - SEE DETAIL

1" GALVANIZED STEEL SUPPORT  
BOLT WITH STD SQUARE HEAD OR  
HEXAGONAL HEAD

**CATCH BASIN OPENING DETAIL**

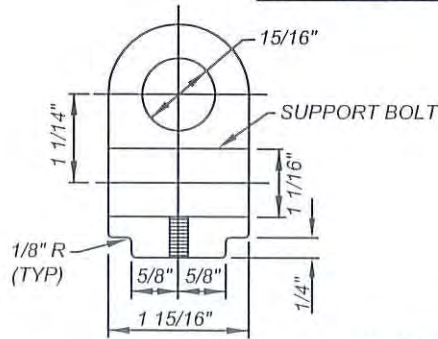

DRILL AND TAP HOLE  
AND INSTALL 3/8" x  
1/2" SOCKET SET  
SCREW WITH 3/16"  
RECESSED HEX HOLE

**STIRRUP DETAIL**

**NOTES:**

- 1) SUPPORT BOLT ANGLE "A" SHALL VARY TO CONFORM WITH BATTER OF ADJOINING CURB.
- 2) PROTECTION BAR SHALL BE INSTALLED AND SUPPORT BOLTS SHALL BE SPACED PER STD MVFE-300D-0.
- 3) SUPPORT BOLTS SHALL BE EQUAL LENGTH TO CURB FACE + 6" FOR ALL CURB BATTER.
- 4) ALL EXPOSED METAL PARTS SHALL BE GALVANIZED AFTER FABRICATION.

NOT TO SCALE



RECOMMENDED:  
*[Signature]* 1/21/14  
DIVISION MANAGER DATE  
APPROVED:  
*[Signature]* 1/29/14  
PUBLIC WORKS DIRECTOR/ DATE  
CITY ENGINEER

**CITY OF MORENO VALLEY**  
PUBLIC WORKS DEPARTMENT - CAPITAL PROJECTS DIVISION

**CATCH BASIN OPENING  
DETAIL**

STANDARD PLAN  
**MVFE-300C-0**

SHEET 3 OF 6



1/2" Ø x 8" STEEL ANCHORS, 15" MAX OC,  
ALTERNATE UPPER "A" AND LOWER "B"  
ANCHORS AS SHOWN

NELSON H-4F SHEAR  
CONNECTOR, KSN WELDING  
SYSTEMS DIVISION SHEAR  
CONNECTOR OR EQUAL

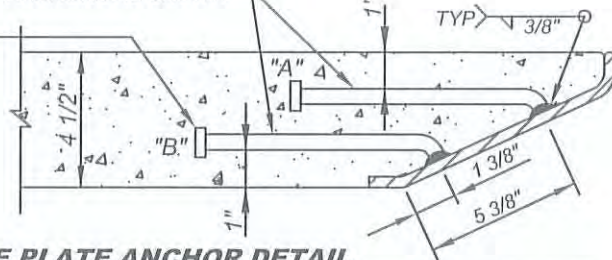

**FACE PLATE ANCHOR DETAIL**

2" x 3" OPENING FOR  
CONCRETE PLACEMENT

INTERIOR FACE OF CATCH  
BASIN END WALL

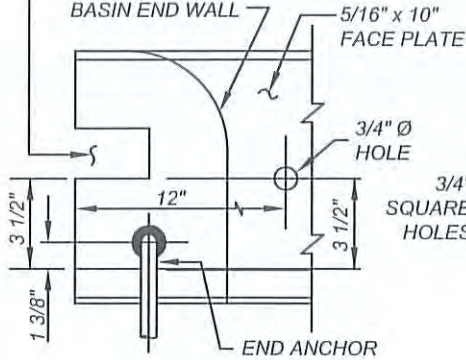

LOCATE WELDS IN  
LONGER SPAN SEGMENT

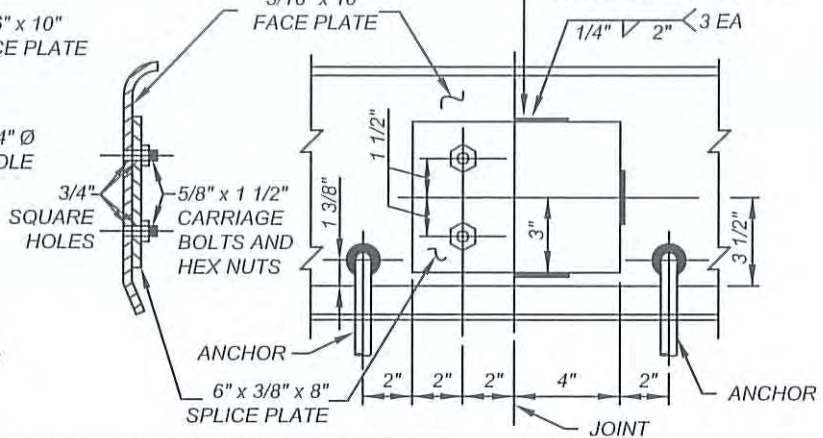

**FACE PLATE END AND SPLICE DETAILS**

END ANCHOR  
WITH  
COUPLING AND  
SET SCREW

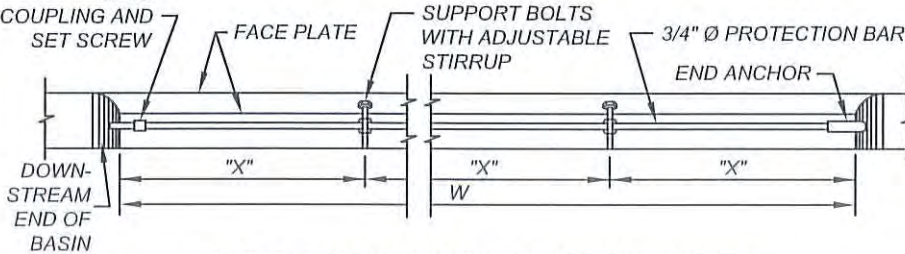

SUPPORT BOLT SPACING		
W	NUMBER OF BOLTS	NUMBER OF "X" LENGTHS
7' TO 10'	1	2
10' TO 15'	2	3
15' TO 20'	3	4
20' TO 25'	4	5
25' TO 30'	5	6

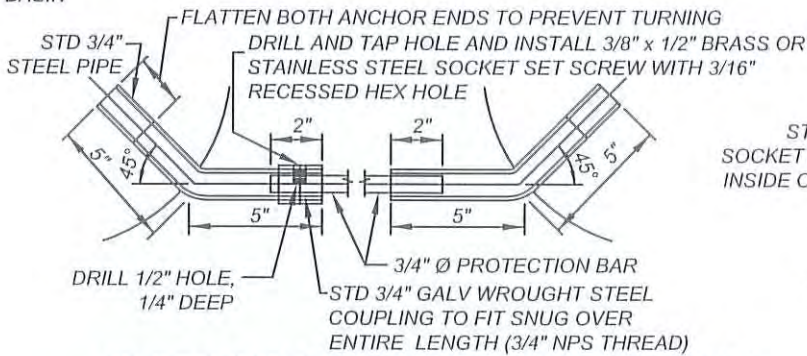

**PROTECTION BAR AND END ANCHOR DETAILS**

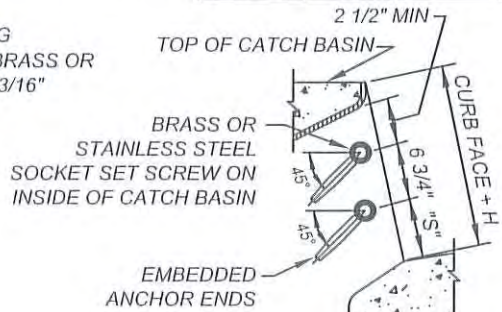

**SECTION VIEW**

NOT TO SCALE

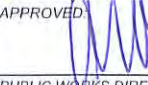

RECOMMENDED:  
 1/21/14  
 DIVISION MANAGER DATE  
 APPROVED:  
 1/29/14  
 PUBLIC WORKS DIRECTOR DATE  
 CITY ENGINEER

**CITY OF MORENO VALLEY**  
 PUBLIC WORKS DEPARTMENT - CAPITAL PROJECTS DIVISION

**CATCH BASIN FACE PLATE AND  
 PROTECTION BAR DETAIL**

STANDARD PLAN  
**MVFE-300D-0**  
 SHEET 4 OF 6



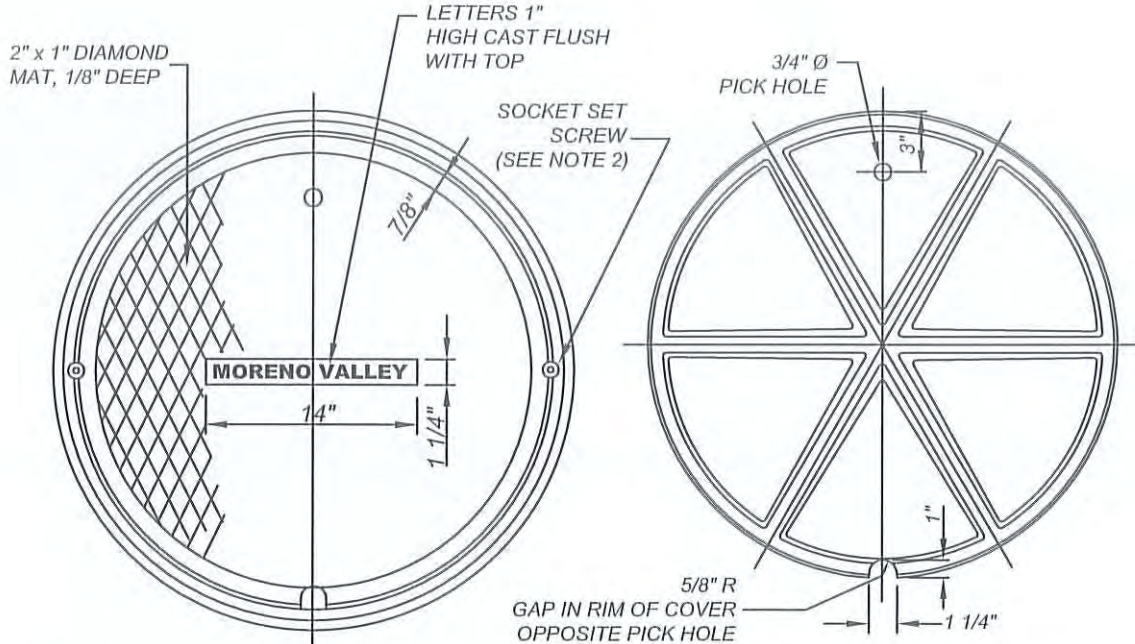

**TOP OF MANHOLE FRAME AND COVER**

**BOTTOM OF MANHOLE COVER**

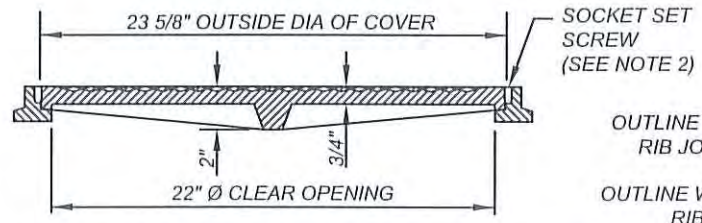

**CROSS SECTION THRU FRAME AND COVER**

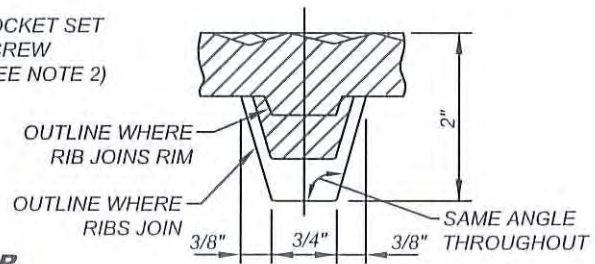

**CROSS SECTION THRU AT MID RADIUS**

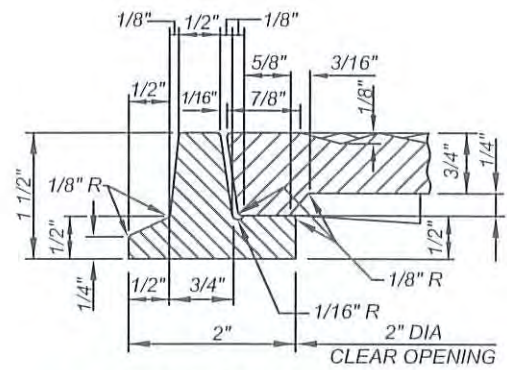

**CROSS SECTION THRU RIM**

**NOTES:**

1. FRAME AND COVER SHALL BE GRAY CAST IRON CONFORMING TO THE LATEST A.S.T.M. STANDARD A48, CLASS 30 OR BETTER, AND GALVANIZED PER A.S.T.M. A385.
2. DRILL AND TAP HOLE AND INSTALL 3/4" x 1 1/4" STAINLESS STEEL SOCKET SET SCREW WITH 3/8" RECESSED HEX HOLE. ALL THREADS TO BE NC.
3. FRAME AND COVER SHALL BE TESTED FOR ACCURACY OF FIT AND SHALL BE MARKED IN SETS BEFORE DELIVERY.
4. TOTAL WEIGHT OF FRAME AND COVER = 130 LBS.

NOT TO SCALE

	RECOMMENDED:  DIVISION MANAGER DATE: 1/21/14	<b>CITY OF MORENO VALLEY</b> PUBLIC WORKS DEPARTMENT - CAPITAL PROJECTS DIVISION		
	APPROVED:  PUBLIC WORKS DIRECTOR / CITY ENGINEER DATE: 1/29/14	<b>CATCH BASIN MANHOLE FRAME AND COVER</b>		STANDARD PLAN <b>MVFE-300E-0</b>
				SHEET 5 OF 6



WALL AND FLOOR STEEL						
W	V (ft)		T (in)	FRONT WALL STEEL		REAR, END WALLS, & FLOOR STEEL (EACH WAY)
	FROM	TO (INCLUDE)		HORIZONTAL	VERTICAL	
TO 7'		4	6	#3 @ 6"	#3 @ 6"	#3 @ 6"
TO 7'	4	8	8	#4 @ 12"	#4 @ 12"	#4 @ 12"
TO 7'	8	12	10	#4 @ 10"	#4 @ 10"	#4 @ 10"
14'		4	6	#3 @ 6"	#3 @ 6"	#3 @ 6"
14'	4	8	8	#4 @ 12"	#4 @ 12"	#4 @ 12"
14'	8	10	10	#4 @ 8"	#4 @ 12"	#4 @ 10"
14'	10	12	10	#4 @ 6"	#4 @ 12"	#4 @ 10"

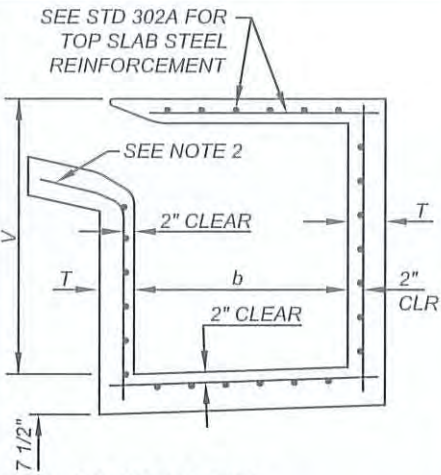

**REINFORCEMENT FOR CATCH BASIN WITH "W" TO 14' (INCLUDE)**

WALL AND FLOOR STEEL							
V (ft)		T (in)	FRONT WALL STEEL	REAR WALL STEEL			END WALL STEEL
FROM	TO (INCLUDE)		BAR A & B	BAR C	BAR D	BAR E	HORIZONTAL & VERTICAL
	4	6	#3 @ 24"	#3 @ 12"	----	#4 @ 24"	#3 @ 18"
4	5	8	#3 @ 20"	#3 @ 12"	----	#4 @ 24"	#3 @ 14"
5	6	8	#3 @ 12"	#3 @ 10 1/2"	----	#4 @ 24"	#3 @ 14"
6	7	8	#4 @ 17"	#3 @ 8 1/2"	----	#4 @ 24"	#3 @ 14"
7	8	8	#4 @ 13"	#3 @ 6 1/2"	----	#4 @ 24"	#3 @ 14"
8	9	10	#4 @ 15"	#3 @ 7 1/2"	----	#4 @ 20"	#3 @ 11"
9	10	10	#4 @ 12"	#4 @ 12"	----	#4 @ 20"	#3 @ 11"
10	11	10	#5 @ 15"	----	#4 @ 11"	#4 @ 18"	#3 @ 11"
11	12	10	#6 @ 18"	----	#4 @ 9"	#4 @ 13"	#3 @ 11"
X = (V + T) - (CF + H + 4 1/2")			Y = ( $\frac{b + 2T}{2}$ ) + 15 DIA. - 2"				



SEE STD MVFE-300A-0 FOR TOP SLAB STEEL REINFORCEMENT

**NOTES:**

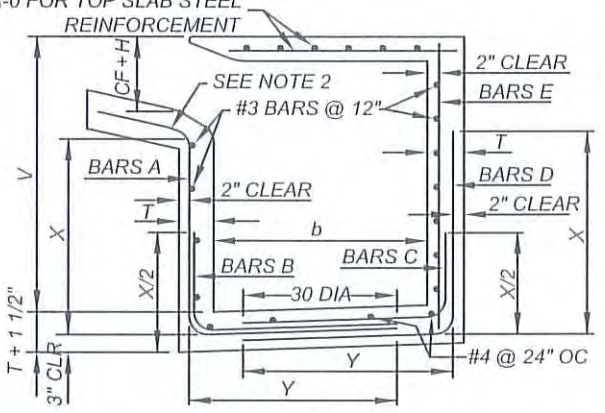
1. REINFORCING STEEL SHOWN HEREON SHALL BE USED FOR ALL CATCH BASIN REGARDLESS OF BASIN LENGTH "W" OF DEPTH "V".
2. VERTICAL BARS SHALL BE EXTENDED INTO LOCAL DEPRESSION AREA.
3. SEE STD MVFE-300A-0 FOR REINFORCEMENT FOR TOP SLAB.

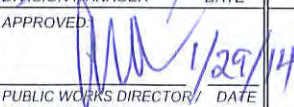

**REINFORCEMENT FOR CATCH BASIN WITH "W" GREATER THAN 14'** NOT TO SCALE

	RECOMMENDED:  DIVISION MANAGER DATE 1/21/14	<b>CITY OF MORENO VALLEY</b> PUBLIC WORKS DEPARTMENT - CAPITAL PROJECTS DIVISION		
	APPROVED:  PUBLIC WORKS DIRECTOR/ CITY ENGINEER DATE 1/29/14	<b>CATCH BASIN REINFORCEMENT</b>		STANDARD PLAN <b>MVFE-300F-0</b>
				SHEET 6 OF 6



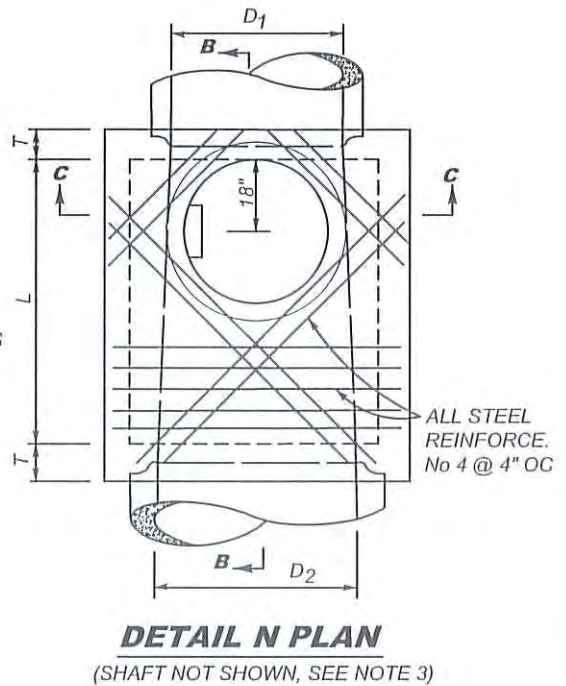
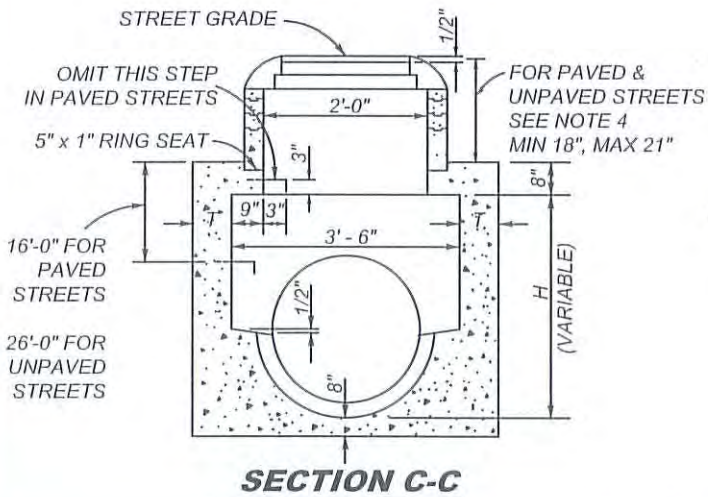
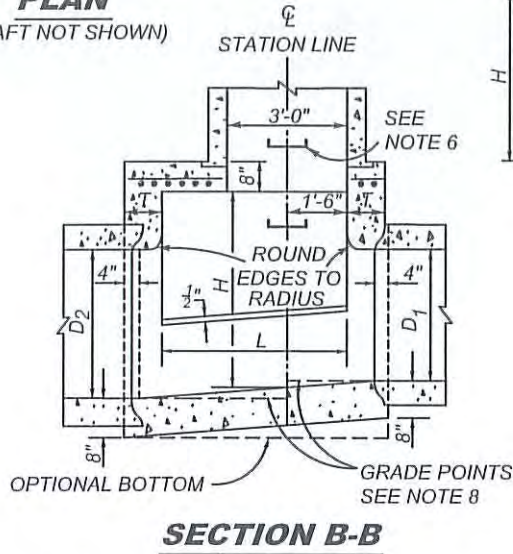
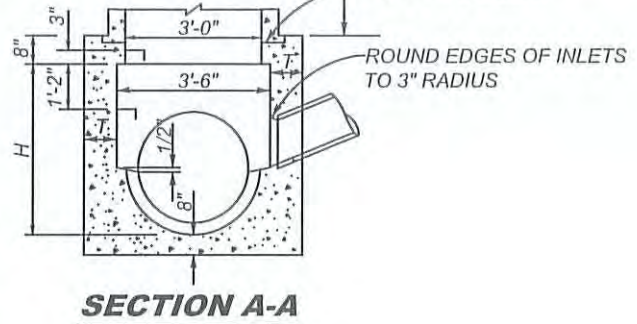
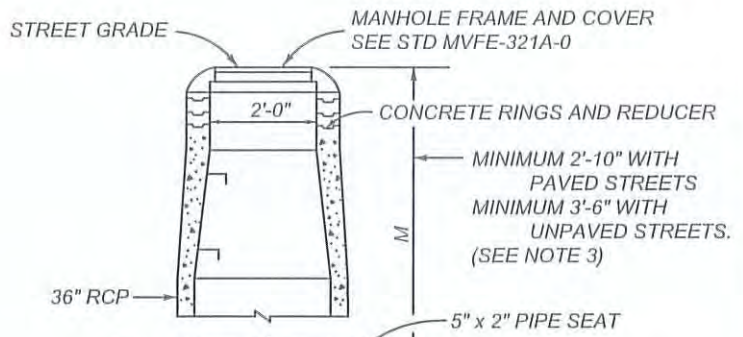
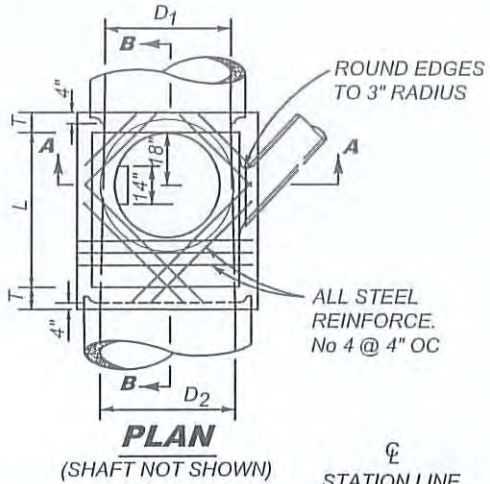

NOT TO SCALE



RECOMMENDED:  
 [Signature] 1/21/14  
 DIVISION MANAGER DATE  
 APPROVED:  
 [Signature] 1/29/14  
 PUBLIC WORKS DIRECTOR / DATE  
 CITY ENGINEER

**CITY OF MORENO VALLEY**  
 PUBLIC WORKS DEPARTMENT - CAPITAL PROJECTS DIVISION

**MANHOLE**

STANDARD PLAN  
**MVFE-320A-0**



SHEET 1 OF 3



**NOTES:**

1. HEIGHT SHALL BE NOT LESS THAN 4'-0" BUT MAY BE INCREASED AT OPTION OF CONTRACTOR PROVIDED THAT THE VALUE OF M SHALL NOT BE LESS THAN THE MINIMUM SPECIFIED AND THAT THE REDUCER SHALL BE USED. FOR H (IN SEC. C-C) SEE NOTE 4.
2. LENGTH L SHALL BE 4" UNLESS OTHERWISE SHOWN ON IMPROVEMENT PLAN. L MAY BE INCREASED OR LOCATION OF MANHOLE SHIFTED TO MEET PIPE ENDS, AT THE OPTION OF CONTRACTOR, EXCEPT THAT ANY CHANGE IN LOCATION OF MANHOLE MUST BE APPROVED BY THE ENGINEER.
3. SHAFT SHALL BE CONSTRUCTED AS PER SECTION C-C AND DETAIL N WHEN DEPTH M FROM STREET GRADE TO TOP OF BOX IS LESS THAN 2'-10 1/2" FOR PAVED STREETS OR 3'-6" FOR UNPAVED STREETS.
4. DEPTH P MAY BE REDUCED TO AN ABSOLUTE LIMIT OF 6" WHEN LARGE VALUES OF P WOULD REDUCE H (IN SECTION C-C) TO BE 3'-6" OR LESS.
5. T SHALL BE 8" FOR VALUE OF H UP TO AND INCLUDING 8'. T SHALL BE 10" FOR VALUE OF H OVER 8'.
6. STEPS SHALL BE 3/4" ROUND, GALVANIZED STEEL AND ANCHORED NOT LESS THAN 4" THE WALLS OF STRUCTURES. UNLESS OTHERWISE SHOWN, STEPS SHALL BE SPACED 16" ON CENTER. THE LOWEST STEP SHALL BE NOT MORE THAN 2" ABOVE THE INVERT.
7. REINFORCING STEEL SHALL BE ROUND, DEFORMED, BARS, No 4 AND 1 1/2" CLEAR FROM INSIDE FACE OF CONCRETE.
8. STATIONS REFER TO PLAN AND PROFILE SHEETS. ELEVATIONS AT C AND PROLONGED INVERT GRADE LINE. SEE NOTE 2 FOR SHIFTING LOCATION.
9. RINGS, REDUCER AND PIPE FOR ACCESS SHAFT SHALL BE SEATED IN CEMENT MORTAR AND NEATLY POINTED OR WIPED INSIDE SHAFT.
10. FLOOR OF MANHOLE SHALL BE STEEL TROWELED TO SPRINGLINE.
11. CONCRETE SHALL BE CLASS "A"

NOT TO SCALE

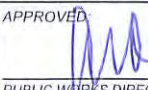
	RECOMMENDED:  DIVISION MANAGER / DATE 1/21/14	<h2 style="margin: 0;">CITY OF MORENO VALLEY</h2> <p style="margin: 0;">PUBLIC WORKS DEPARTMENT - CAPITAL PROJECTS DIVISION</p>	STANDARD PLAN <h3 style="margin: 0;">MVFE-320B-0</h3>
	APPROVED:  PUBLIC WORKS DIRECTOR / DATE 1/29/14 CITY ENGINEER	<h2 style="margin: 0;">MANHOLE NOTES</h2>	SHEET 2 OF 3
	PUBLIC WORKS DIRECTOR / DATE CITY ENGINEER		

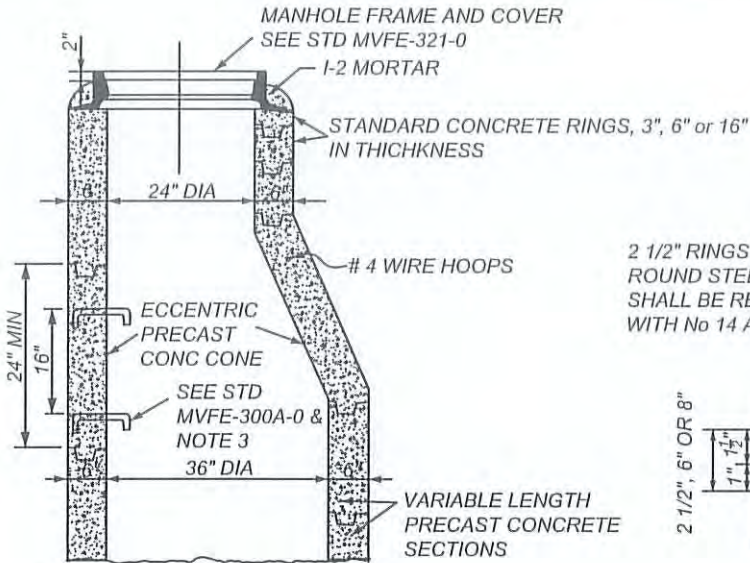

**VERTICAL SECTION  
OF PLAIN CONCRETE  
ECCENTRIC MANHOLE SHAFT**

2 1/2" RINGS SHALL BE REINFORCED WITH TWO 1/4 ROUND STEEL HOOPS, 6" AND 8" RINGS SHALL BE REINFORCED WITH FOUR HOOPS, TIED WITH No 14 A.S. & W. GAUGE WIRE, 8" OC

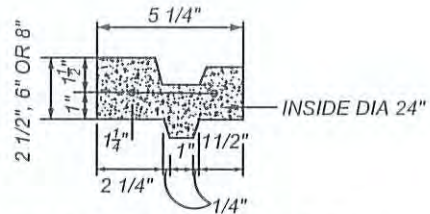

**CROSS SECTION OF  
REINFORCED CONCRETE RING**

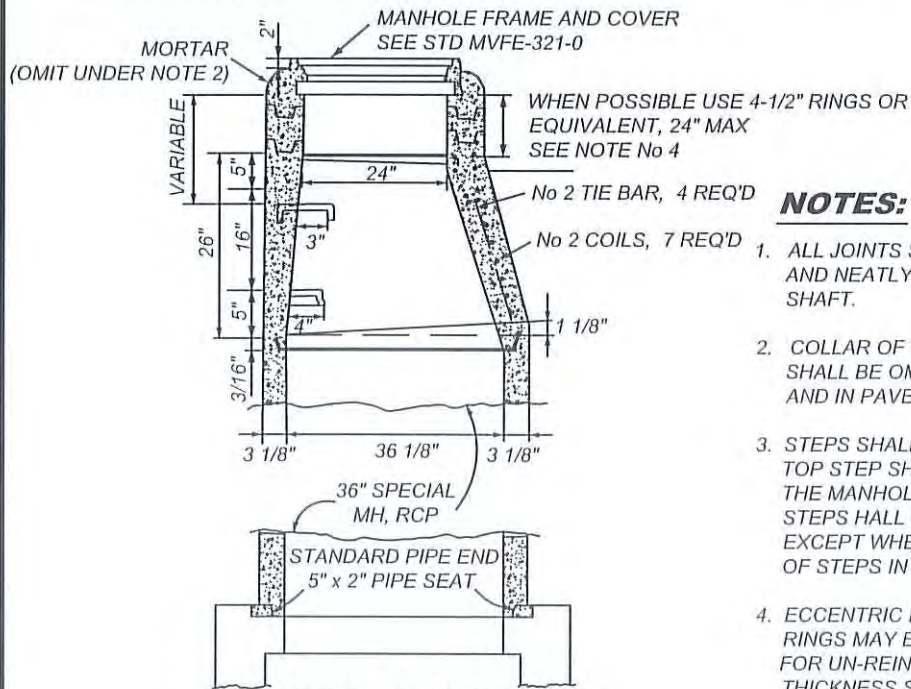

**VERTICAL SECTION  
OF REINFORCED CONCRETE  
ECCENTRIC MANHOLE SHAFT**

**NOTES:**

1. ALL JOINTS SHALL BE FILLED WITH 1-2 MORTAR AND NEATLY PAINTED OR WIPED ON INSIDE OF SHAFT.
2. COLLAR OF 1-2 MORTAR AROUND COVER FRAME SHALL BE OMITTED IN ROCK AND OIL STREETS AND IN PAVED STREETS.
3. STEPS SHALL BE 3/4" ROUND GALVANIZED STEEL. TOP STEP SHALL BE PLACED DIRECTLY BENEATH THE MANHOLE FRAME AND COVER. WIDTH OF ALL STEPS SHALL BE 14" BETWEEN LEG CENTERS. EXCEPT WHERE SHOWN OTHERWISE, SPACING OF STEPS IN SHAFT SHALL BE 16" CENTER.
4. ECCENTRIC MANHOLE: SHAFT, REDUCER AND RINGS MAY BE PLAIN CONCRETE. FOR UN-REINFORCED SECTIONS, THE MINIMUM THICKNESS SHALL BE 6". THE CONCRETE USED SHALL BE CLASS "A".

NOT TO SCALE



RECOMMENDED:  
 DIVISION MANAGER DATE 1/21/14  
 APPROVED:  
 PUBLIC WORKS DIRECTOR / DATE 1/29/14  
 CITY ENGINEER

**CITY OF MORENO VALLEY**  
 PUBLIC WORKS DEPARTMENT - CAPITAL PROJECTS DIVISION

**MANHOLE SHAFT FOR  
CAST PIPE**

STANDARD PLAN  
**MVFE-320C-0**

SHEET 3 OF 3



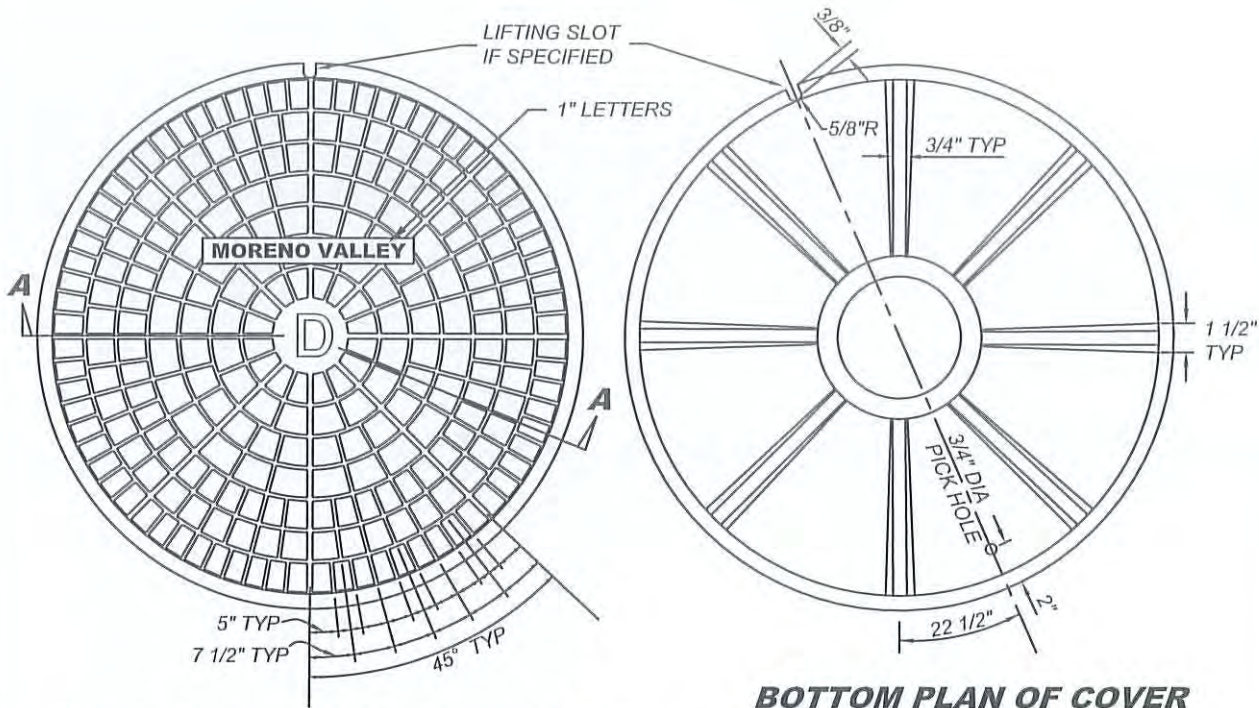

**BOTTOM PLAN OF COVER**

**COVER FOR 24\"/>**

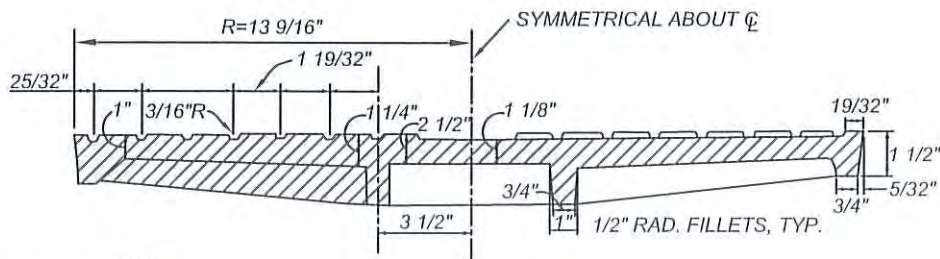

**SECTION A-A**

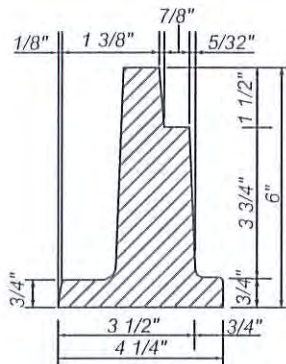

**DETAIL OF FRAME**

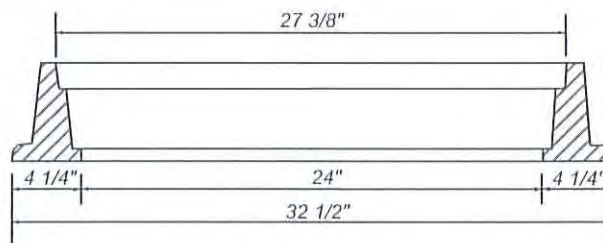

**SECTION THRU FRAME**

NOT TO SCALE

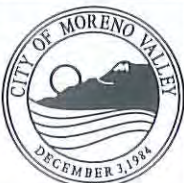

RECOMMENDED:  
 DIVISION MANAGER *[Signature]* 1/21/14  
 DATE  
 APPROVED:  
 PUBLIC WORKS DIRECTOR *[Signature]* 1/29/14  
 DATE  
 CITY ENGINEER

**CITY OF MORENO VALLEY**  
 PUBLIC WORKS DEPARTMENT - CAPITAL PROJECTS DIVISION

**MANHOLE FRAME AND COVER**



STANDARD PLAN  
**MVFE-321A-0**

SHEET 1 OF 2

**NOTES:**

1. THE CAST IRON USED SHALL CONFORM WITH ASTM A-48 CLASS 35B.
2. THE FRAME AND COVER SHALL BE COATED WITH ASPHALTUM OR BITUMINOUS PAINT AFTER TESTING AND INSPECTION.
3. COVERS SHALL BE CAST WITH THE LETTERS "D" AND "RCFC & WCD". THE LETTER "D" SHALL BE APPROXIMATELY 2 1/2 INCHES HIGH WITH 1/2 INCH LINE WIDTH AND PLACED IN THE CENTER OF THE COVER. ALL LETTERS SHALL BE FLUSH WITH THE FINISHED SURFACE OF THE COVER.
4. FOUNDRY IDENTIFYING MARK, HEAT AND DATE SHALL BE CAST ON THE BOTTOM OF THE COVER AND ON THE INSIDE OF THE FRAME.
5. IMPORTED COVERS AND FRAMES SHALL HAVE THE COUNTRY OF ORIGIN MARKING IN COMPLIANCE WITH FEDERAL REGULATIONS.
6. WEIGHT OF FRAME SHALL BE 265 POUNDS. WEIGHT OF COVER SHALL BE 175 POUNDS. ACTUAL WEIGHT SHALL BE WITHIN A RANGE OF 95% TO 110%.
7. THE MANHOLE FRAME AND COVER SHALL BE INSPECTED BY THE ENGINEER PRIOR TO SHIPMENT TO THE JOB SITE. ACCEPTANCE WILL BE INDICATED BY THE AGENCY'S MARK.
8. THE PROOF-LOAD FOR TEST METHOD B OF THE STANDARD SPECIFICATION IS 40,700 POUNDS.
9. COVERS FOR MANHOLES LOCATED IN EASEMENTS, ALLEYS, PARKWAYS AND ALL OTHER PLACES EXCEPTS PAVED STREETS SHALL BE PROVIDED WITH SOCKET SET SCREW LOCKING DEVICES. DRILL AND TAP TWO HOLES TO A DEPTH OF ONE INCH AT 90 DEGREES TO PICK HOLE AND INSTALL 3/4 INCH x 3/4 INCH STAINLESS STEEL SOCKET SET SCREWS WITH 3/8 INCH RECESSED HEX HEAD. ALL THREADS SHALL BE N.C.

NOT TO SCALE

	RECOMMENDED:  1/21/14 DIVISION MANAGER      DATE	<b>CITY OF MORENO VALLEY</b> PUBLIC WORKS DEPARTMENT - CAPITAL PROJECTS DIVISION	STANDARD PLAN <b>MVFE-321B-0</b>
	APPROVED:  1/29/14 PUBLIC WORKS DIRECTOR / DATE CITY ENGINEER	<b>MANHOLE FRAME AND COVER NOTES</b>	SHEET 2 OF 2



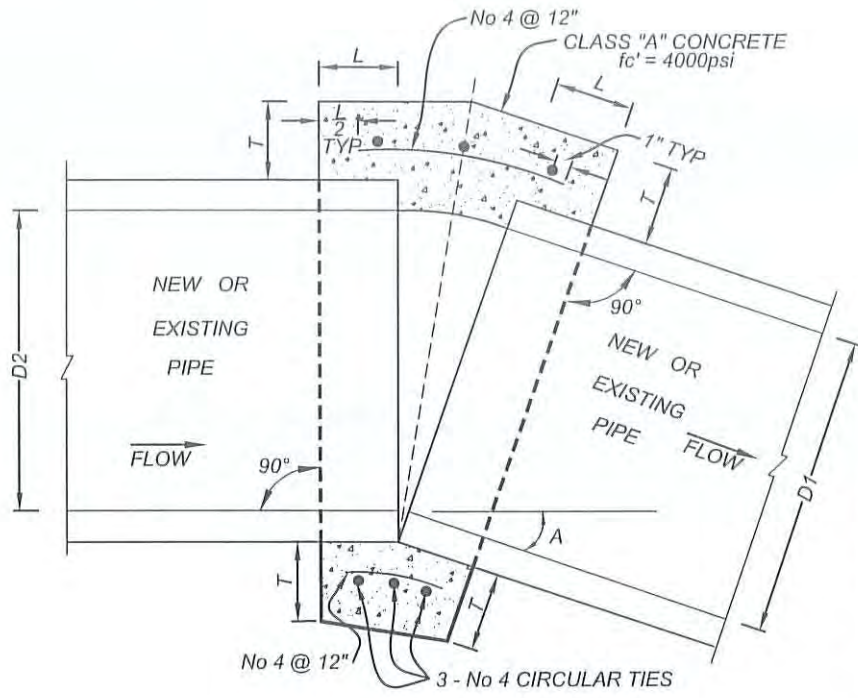

D	L	T
24"	1.0'	6"
36"	1.5'	8"
48"	1.5'	10"
57"	1.5'	10"
60"	1.75'	11"
66"	1.75'	11"

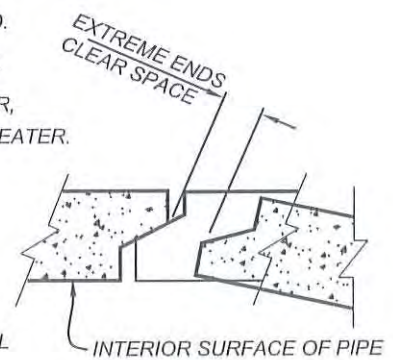

**NOTES:**

1. A CONCRETE COLLAR IS REQUIRED WHERE THE CHANGE IN GRADE EXCEEDS 0.10 FT. PER FOOT, OR IF CHANGE IN ALIGNMENT EXCEEDS 0.10 FT. PER FOOT.
2. IF THE EXTREME ENDS OF THE PIPE LEAVE A CLEAR SPACE THAT IS GREATER THAN 1", BUT LESS THAN 6", A CONCRETE COLLAR IS REQUIRED (SEE DETAIL A) IF THE CLEAR SPACE IS 6" OR GREATER, A TRANSITION STRUCTURE IS REQUIRED.
3. CONCRETE COLLAR SHALL NOT BE USED FOR A SIZE CHANGE ON THE MAIN LINE.
4. WHERE PIPES OF DIFFERENT DIAMETERS ARE JOINED WITH A CONCRETE COLLAR, L AND T SHALL BE THOSE OF THE LARGER PIPE.  $D = D_1$  OR  $D_2$ , WHICHEVER IS GREATER.
5. FOR PIPE LARGER THAN 66" A SPECIAL COLLAR DETAIL IS REQUIRED.
6. FOR PIPE SIZE NOT LISTED USE THE NEXT SIZE LARGER.
7. OMIT REINFORCING ON PIPES 24" AND LESS IN DIAMETER AND ON ALL PIPES WHERE ANGLE A IS LESS THAN 10°.
8. WHERE REINFORCING IS REQUIRED THE DIAMETER OF THE CIRCULAR TIES SHALL BE  $D + (2 \times \text{WALL THICKNESS}) + 8"$ .
9. WHEN D IS EQUAL TO OR LESS THAN D JOIN INVERTS AND WHEN D IS GREATER THAN D<sub>2</sub> JOIN SOFFITS.
10. PIPE MAY BE CORRUGATED METAL PIPE, CONCRETE PIPE, OR REINFORCED CONCRETE PIPE.



**DETAIL "A"**  
TYPICAL JOINT FOR  
REINFORCED CONCRETE PIPE

NOT TO SCALE

	RECOMMENDED:  1/21/14 DIVISION MANAGER DATE	<b>CITY OF MORENO VALLEY</b> PUBLIC WORKS DEPARTMENT - CAPITAL PROJECTS DIVISION	STANDARD PLAN <b>MVFE-340-0</b>
	APPROVED:  1/29/14 PUBLIC WORKS DIRECTOR / DATE CITY ENGINEER	<b>CONCRETE COLLAR</b> <b>FOR PIPE 24 THROUGH 36 INCHES</b>	





**NPDES NOTES:**

- 1.) EROSION CONTROL BMPs SHALL BE IMPLEMENTED AND MAINTAINED TO MINIMIZE AND/OR PREVENT THE ENTRAINMENT OF SOIL IN RUNOFF FROM DISTURBED SOIL AREAS ON CONSTRUCTION SITES.
- 2.) SEDIMENT CONTROL BMPs SHALL BE IMPLEMENTED AND MAINTAINED TO PREVENT AND/OR MINIMIZE THE TRANSPORT OF SOIL FROM THE CONSTRUCTION SITE.
- 3.) STOCKPILES OF SOIL SHALL BE PROPERLY CONTAINED TO ELIMINATE OR REDUCE SEDIMENT TRANSPORT FROM THE SITE TO STREETS, DRAINAGE FACILITIES OR ADJACENT PROPERTIES VIA RUNOFF, VEHICLE TRACKING, OR WIND.
- 4.) APPROPRIATE BMPs FOR CONSTRUCTION-RELATED MATERIALS, WASTES, SPILLS OR RESIDUES SHALL BE IMPLEMENTED TO ELIMINATE OR REDUCE TRANSPORT FROM THE SITE TO STREETS, DRAINAGE FACILITIES, OR ADJOINING PROPERTIES BY WIND OR RUNOFF.
- 5.) RUNOFF FROM EQUIPMENT AND VEHICLE WASHING SHALL BE CONTAINED AT CONSTRUCTION SITES AND MUST NOT BE DISCHARGED TO RECEIVING WATERS OR THE LOCAL STORM DRAIN SYSTEM.
- 6.) ALL CONSTRUCTION CONTRACTOR AND SUBCONTRACTOR PERSONNEL ARE TO BE MADE AWARE OF THE REQUIRED BEST MANAGEMENT PRACTICES AND GOOD HOUSEKEEPING MEASURES FOR THE PROJECT SITE AND ANY ASSOCIATED CONSTRUCTION STAGING AREAS.
- 7.) AT THE END OF EACH DAY OF CONSTRUCTION ACTIVITY ALL CONSTRUCTION DEBRIS AND WASTE MATERIALS SHALL BE COLLECTED AND PROPERLY DISPOSED IN TRASH OR RECYCLE BINS.
- 8.) CONSTRUCTION SITES SHALL BE MAINTAINED IN SUCH A CONDITION THAT A STORM DOES NOT CARRY WASTES OR POLLUTANTS OFF THE SITE. DISCHARGES OTHER THAN STORMWATER (NON-STORMWATER DISCHARGES) ARE PROHIBITED, EXCEPT AS AUTHORIZED BY AN INDIVIDUAL NPDES PERMIT OR THE STATEWIDE GENERAL PERMIT-CONSTRUCTION. POTENTIAL POLLUTANTS INCLUDE BUT ARE NOT LIMITED TO: SOLID OR LIQUID CHEMICAL SPILLS; WASTES FROM PAINTS, STAINS, SEALANTS, SOLVENTS, DETERGENTS, GLUES, LIME, PESTICIDES, HERBICIDES, FERTILIZERS, WOOD PRESERVATIVES, AND ASBESTOS FIBERS, PAINT FLAKES OR STUCCO FRAGMENTS; FUELS, OILS, LUBRICANTS, AND HYDRAULIC, RADIATOR OR BATTERY FLUIDS; CONCRETE AND RELATED CUTTING OR CURING RESIDUES; FLOATABLE WASTES; WASTES FROM ENGINE/EQUIPMENT STEAM CLEANING OR CHEMICAL DEGREASING; WASTES FROM STREET CLEANING; AND SUPER-CHLORINATED POTABLE WATER FROM LINE FLUSHING AND TESTING. DURING CONSTRUCTION, DISPOSAL OF SUCH MATERIALS SHOULD OCCUR IN A SPECIFIED AND CONTROLLED TEMPORARY AREA ON-SITE PHYSICALLY SEPARATED FROM POTENTIAL STORMWATER RUNOFF, WITH ULTIMATE DISPOSAL IN ACCORDANCE WITH LOCAL, STATE AND FEDERAL REQUIREMENTS.
- 9.) DISCHARGING CONTAMINATED GROUNDWATER PRODUCED BY DEWATERING GROUNDWATER THAT HAS INFILTRATED INTO THE CONSTRUCTION SITE IS PROHIBITED. DISCHARGING OF CONTAMINATED SOILS VIA SURFACE EROSION IS ALSO PROHIBITED. DISCHARGING NON-CONTAMINATED GROUNDWATER PRODUCED BY DEWATERING ACTIVITIES MAY REQUIRE A NATIONAL POLLUTANT DISCHARGE ELIMINATION SYSTEM (NPDES) PERMIT ISSUED BY THE REGIONAL BOARD.
- 10.) CONSTRUCTION SITES SHALL BE MANAGED TO MINIMIZE THE EXPOSURE TIME OF DISTURBED SOIL AREAS THROUGH PHASING AND SCHEDULING OF GRADING TO THE EXTENT FEASIBLE AND THE USE OF TEMPORARY AND PERMANENT SOIL STABILIZATION.
- 11.) BMPs SHALL BE MAINTAINED AT ALL TIMES. IN ADDITION, BMPs SHALL BE INSPECTED PRIOR TO PREDICTED STORM EVENTS AND FOLLOWING STORM EVENTS.

NOTE: THESE NOTES SHALL BE PLACED ON THE EROSION CONTROL SHEET OF ALL GRADING PLANS.

NOT TO SCALE

	RECOMMENDED:  12/14 DIVISION MANAGER DATE	<b>CITY OF MORENO VALLEY</b> PUBLIC WORKS DEPARTMENT - LAND DEVELOPMENT DIVISION	STANDARD PLAN <b>MVFE-350-0</b>
	APPROVED:  12/29/14 PUBLIC WORKS DIRECTOR / DATE CITY ENGINEER		<b>NPDES NOTES</b>

**EROSION CONTROL GRADING REQUIREMENTS**

1. ALL EARTHWORK PERFORMED TO CONSTRUCT EROSION CONTROL MEASURES SHALL CONFORM TO CITY GRADING REGULATIONS.
2. YARDAGE SHOWN ON THE PLANS ARE APPROXIMATE ESTIMATES OF WORK TO BE DONE AND THE CONTRACTOR SHALL VERIFY FIELD CONDITIONS AND QUANTITIES PRIOR TO COMMENCING WORK.
3. THE CONTRACTOR SHALL MAKE PROVISION FOR CONTRIBUTORY DRAINAGE AT ALL TIMES UNTIL WORK IS ACCEPTED BY THE CITY. THE EROSION CONTROL DEVICES SHOWN ON PLANS SHALL REMAIN IN OPERABLE CONDITION BY THE CONTRACTOR.
4. EXISTING STRUCTURES AND DEBRIS FOUND WITHIN WORK AREA SHALL BE REMOVED FROM SITE AND DISPOSED OF BY THE CONTRACTOR.
5. ROCK DISPOSAL AREAS ARE SHOWN ON PLANS. NO ROCK GREATER THAN 12" IN DIAMETER WILL BE PLACED IN THE FILL, UNLESS APPROVED BY THE SOILS ENGINEER.
6. FILL PLACED OVER EXISTING SLOPING TERRAIN SHALL BE SUPPORTED ON HORIZONTAL BENCH CUT INTO COMPETENT MATERIAL.
7. ANY MODIFICATIONS TO PLAN SHALL REQUIRE THE APPROVAL OF A REGISTERED CIVIL ENGINEER.
8. FILL SHALL BE COMPACTED TO 95 % OF MAXIMUM DENSITY AS DETERMINED BY A.S.T.M. SOIL COMPACTION TEST D1557. ONE FIELD TEST TO BE MADE FOR EACH TWO FOOT OF VERTICAL LIFT.
9. THE SOIL ENGINEER SHALL PROVIDE SUFFICIENT INSPECTION OF EARTHWORK TO ENSURE COMPLIANCE WITH THE APPROVED PLANS AND APPLICABLE CODES.



**EROSION CONTROL MAINTENANCE & INSPECTION:**

1. A STANDBY CREW FOR EMERGENCY WORK SHALL BE AVAILABLE DURING THE RAINY SEASON AT ALL TIMES. CONTACT THE CONTRACTOR AT ( ) IN CASE OF EMERGENCY.
2. ALL SILT AND DEBRIS SHALL BE REMOVED FROM ALL DEVICES WHENEVER SUCH MAY POSE A POTENTIAL HAZARD DOWNSTREAM.
3. THE PLACEMENT OF ADDITIONAL DEVICES TO REDUCE EROSION DAMAGE IS AT THE DISCRETION OF THE CITY INSPECTOR.
4. PLANTING AND IRRIGATION OF SLOPES SHALL BE THE RESPONSIBILITY OF THE CONTRACTOR.
5. A PREVENTIVE PROGRAM TO PROTECT SLOPES FROM POTENTIAL DAMAGE FROM BURROWING RODENTS IS REQUIRED. CONTRACTOR SHALL PERIODICALLY INSPECT SLOPES FOR EVIDENCE OF BURROWING RODENTS.

**NOTE:**

- 1.) THESE NOTES SHALL BE PLACED ON ALL ROUGH GRADING PLANS.

NOT TO SCALE

	RECOMMENDED: 	12/11/17 DATE	<b>CITY OF MORENO VALLEY</b> PUBLIC WORKS DEPARTMENT - LAND DEVELOPMENT DIVISION
	DIVISION MANAGER		
	APPROVED: 	9/14/18 DATE	<b>EROSION CONTROL NOTES (ROUGH GRADING PHASE)</b>
PUBLIC WORKS DIRECTOR/ CITY ENGINEER			STANDARD PLAN <b>MVFE-351A-0</b> SHEET 1 OF 6

**CURB INLET SEDIMENT BARRIERS CONSTRUCTION SPECIFICATIONS:**

1. BARRIERS SHALL BE PLACED ON GENTLY SLOPING STREETS WHERE WATER CAN POND PER STD PLAN MVFE-353.
2. THE BARRIERS SHALL ALLOW FOR OVERFLOW FROM A SEVERE STORM EVENT. SLOPE RUNOFF SHALL BE CONTROLLED USING STD PLANS MVFE-355 OR MVFE-356. A SPILLWAY SHALL BE CONSTRUCTED WITH THE SANDBAG STRUCTURES TO ALLOW OVERFLOW.
3. GRAVEL BAGS SHOULD BE OF WOVEN-TYPE GEOTEXTILE FABRIC.
4. GRAVEL BAGS SHALL BE FILLED WITH 3/4 INCH DRAIN ROCK OR 1/4 INCH PEA GRAVEL.
5. GRAVEL BAGS SHALL BE PLACED IN A CURVED ROW FROM THE TOP OF CURB AT LEAST 4 FEET INTO THE STREET. THE ROW SHOULD BE CURVED AT THE ENDS, POINTING UPHILL.
6. LAYERS OF BAGS SHALL BE OVER LAPPED AND PACKED TIGHTLY.
7. LEAVE ONE GRAVEL BAG GAP IN THE TOP ROW TO ACT AS A SPILLWAY.



**INSPECTION AND MAINTENANCE:**

1. THE CONTRACTOR SHALL INSPECT AND CLEAN BARRIER DURING AND AFTER EACH STORM AND REMOVE SEDIMENT FROM BEHIND GRAVEL BAG STRUCTURE AFTER EACH STORM.
2. ANY SEDIMENT AND GRAVEL SHALL BE IMMEDIATELY REMOVED FROM THE TRAVELED WAY OF ROADS.
3. THE REMOVED SEDIMENT SHALL BE PLACED WHERE IT CANNOT ENTER A STORM DRAIN, STREAM, OR BE TRANSPORTED OFF SITE.
4. IF THE GRAVEL BECOMES CLOGGED WITH SEDIMENT, IT MUST BE REMOVED FROM THE INLET AND OR REPLACED WITH NEW GRAVEL.
5. IT IS IMPERATIVE THAT EROSION CONTROL MEASURES ARE IN PLACE AT THE SOURCE IN ADDITION TO PROTECTING THE CATCH BASINS AND CURB INLETS DOWNSTREAM.

**NOTE:**

- 1.) THESE NOTES SHALL BE PLACED ON ALL PRECISE GRADING PLANS.

NOT TO SCALE

	RECOMMENDED:  12/11/17 DIVISION MANAGER      DATE	<b>CITY OF MORENO VALLEY</b> PUBLIC WORKS DEPARTMENT - LAND DEVELOPMENT DIVISION	
	APPROVED:  9/14/18 PUBLIC WORKS DIRECTOR / DATE CITY ENGINEER	<b>EROSION CONTROL NOTES (PRECISE GRADING PHASE)</b>	



**STRAW - BALE SEDIMENT BARRIERS (SEMI-PERVIOUS) CONSTRUCTION SPECIFICATIONS:**

1. THE ROCK SPILLWAY SHALL BE CONSTRUCTED OF GRADED DRAIN ROCK, 1-1/2 INCH MINIMUM, THAT IS SIZED ACCORDING TO EXPECTED FLOWS. FILTER FABRIC MAY BE USED TO COVER THE BALES AND BE ENVELOPED IN THE ROCK SPILLWAY.
2. THE ROCK SPILLWAY SHALL BE CONSTRUCTED TO A HEIGHT OF 2/3 THAT OF THE STRAW BALES.
3. THE MAXIMUM HEIGHT OF THE SPILLWAY SHALL BE 2 FEET.
4. PLACE BALES IN A SINGLE ROW, LENGTH WISE, ORIENTED PERPENDICULAR TO THE FLOW, AND WITH ENDS OF ADJACENT BALES TIGHTLY ABUTTING ONE ANOTHER.
5. EACH BALE SHALL BE EMBEDDED IN THE SOIL A MINIMUM OF 4 INCHES. USE STRAW, ROCKS, OR FILTER FABRIC TO FILL ANY GAPS BETWEEN THE BALES AND TAMP THE BACKFILL MATERIAL TO PREVENT EROSION UNDER OR AROUND THE BALES.
6. IF THE BALES ARE WIRE BOUND, THEY SHOULD BE ORIENTED SO BINDINGS ARE AROUND THE SIDES RATHER THAN ALONG THE TOP OR BOTTOM. WIRE BINDING THAT ARE PLACED IN CONTACT WITH SOIL SOON DISINTEGRATE AND MAY ALLOW THE BALE TO FALL APART.
7. THE BALES SHALL BE SECURELY ANCHORED IN PLACE BY TWO WOODEN STAKES OR REBAR DRIVEN THROUGH THE BALES. THE FIRST STAKE IN EACH BALE SHALL BE DRIVEN TOWARD THE PREVIOUSLY LAID BALE TO FORCE THE BALES TIGHTLY TOGETHER. DRIVE THE STAKES AT LEAST 18 INCHES (0.5 m) INTO THE GROUND. PROPER STAKING IS PARTICULARLY IMPORTANT IN CHANNEL FLOW APPLICATIONS.
8. EXTEND THE BARRIER, ACROSS THE SWALE TO SUCH A LENGTH THAT THE BOTTOMS OF END BALE ARE AT A HIGHER ELEVATION THAN THE TOP OF THE ROCK SPILLWAY TO ASSURE THAT SEDIMENT-LADEN RUNOFF WILL FLOW THROUGH OR OVER THE BARRIER BUT NOT AROUND IT.
9. ROCK AND/OR FILTER FABRIC SHALL BE PLACED IMMEDIATELY DOWNSTREAM OF THE ROCK THAT WILL DISSIPATE THE ENERGY OF THE FALLING WATER AND REDUCE DOWNSTREAM EROSION.



**INSPECTION AND MAINTENANCE**

1. THE SEMI-PERVIOUS STRAW BALE BARRIERS SHALL BE INSPECTED PERIODICALLY DURING THE WINTER AND AFTER EACH SIGNIFICANT STORM ( 1 INCH IN 24 HRS). REPAIRS AND/OR REPLACEMENT SHALL BE MADE PROMPTLY.
2. SEDIMENT SHALL BE REMOVED WHEN THE BARRIER IS 60 PERCENT FULL. THE REMOVED SEDIMENT SHALL BE DEPOSITED IN AN AREA THAT WILL NOT CONTRIBUTE SEDIMENT OFF-SITE AND CAN BE PERMANENTLY STABILIZED.
3. REMOVE THE STRAW BALES AND STAKES, AND REMOVE OR SPREAD THE ROCK IN THE CHANNEL BOTTOM WHEN THE UPSLOPE AREAS HAVE BEEN PERMANENTLY STABILIZED.
4. PROPERLY DISPOSE OF ALL THE BINDINGS WHICH HAVE FALLEN FROM THE STRAW BALES.

**NOTE:**

- 1.) THESE NOTES SHALL BE PLACED ON ALL GRADING PLANS WHERE STRAW-BALE BARRIERS ARE REQUIRED.



NOT TO SCALE

	RECOMMENDED:  DIVISION MANAGER	12/11/17 DATE	<b>CITY OF MORENO VALLEY</b> PUBLIC WORKS DEPARTMENT - LAND DEVELOPMENT DIVISION
	APPROVED:  PUBLIC WORKS DIRECTOR/ CITY ENGINEER	9/14/18 DATE	<b>EROSION CONTROL NOTES                  (STRAW-BALE BARRIERS)</b>

**STORM WATER POLLUTION CONTROL REQUIREMENTS**

1. ERODED SEDIMENTS AND OTHER POLLUTANTS SHALL BE RETAINED ON SITE AND SHALL NOT BE TRANSPORTED FROM THE SITE VIA SHEET FLOW, SWALES, AREA DRAINS, NATURAL DRAINAGE COURSES OR WIND.
2. STOCKPILES OF EARTH AND OTHER CONSTRUCTION RELATED MATERIALS SHALL BE PROTECTED.
3. FUELS, OILS, SOLVENTS, AND OTHER TOXIC MATERIALS SHALL BE STORED IN ACCORDANCE WITH THEIR LISTINGS AND ARE NOT TO CONTAMINATE THE SOIL, AND SURFACE WATERS. ALL APPROVED STORAGE CONTAINERS ARE TO BE PROTECTED FROM THE WEATHER. SPILLS MUST BE CLEANED UP IMMEDIATELY AND DISPOSED OF IN A PROPER MANNER. SPILLS SHALL NOT BE WASHED INTO THE DRAINAGE SYSTEM.
4. EXCESS OR WASTE CONCRETE SHALL NOT BE WASHED INTO THE PUBLIC RIGHT-OF-WAY OR ANY OTHER DRAINAGE SYSTEM, PROVISIONS SHALL BE MADE TO RETAIN CONCRETE WASTES ON SITE UNTIL THEY CAN BE DISPOSED OF AS SOLID WASTE.
5. TRASH AND CONSTRUCTION RELATED SOLID WASTES SHALL BE DEPOSITED INTO A COVERED RECEPTACLE TO PREVENT CONTAMINATIONS OF RAINWATER AND DISPERSAL BY WIND.
6. SEDIMENTS AND OTHER MATERIALS SHALL NOT BE TRACKED FROM THE SITE BY VEHICLE TRAFFIC. THE CONSTRUCTION ENTRANCE ROADWAYS SHALL BE STABILIZED SO AS TO INHIBIT SEDIMENTS FROM BEING DEPOSITED INTO THE PUBLIC RIGHT-OF-WAY. ACCIDENTAL DEPOSITIONS SHALL BE SWEEPED UP IMMEDIATELY AND SHALL NOT BE WASHED DOWN BY RAIN OR OTHER MEANS.
7. ANY SLOPES WITH DISTURBED SOILS OR DENUDED OF VEGETATION SHALL BE STABILIZED SO AS TO INHIBIT EROSION BY WIND AND WATER.
8. THE CASQA STORMWATER BMP HANDBOOK, LATEST REVISED EDITION, SHALL APPLY DURING CONSTRUCTION (ADDITIONAL MEASURES SHALL BE REQUIRED IF DEEMED APPROPRIATE BY THE CITY):

NOT TO SCALE

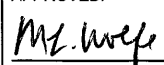
	RECOMMENDED: 	<h2 style="margin: 0;">CITY OF MORENO VALLEY</h2> <p style="margin: 0;">PUBLIC WORKS DEPARTMENT - LAND DEVELOPMENT DIVISION</p>	
	12/11/17 DIVISION MANAGER      DATE	<h3 style="margin: 0;">EROSION CONTROL NOTES</h3>	
	APPROVED: 	SHEET 4 OF 6	
	9/14/18 PUBLIC WORKS DIRECTOR / DATE CITY ENGINEER		

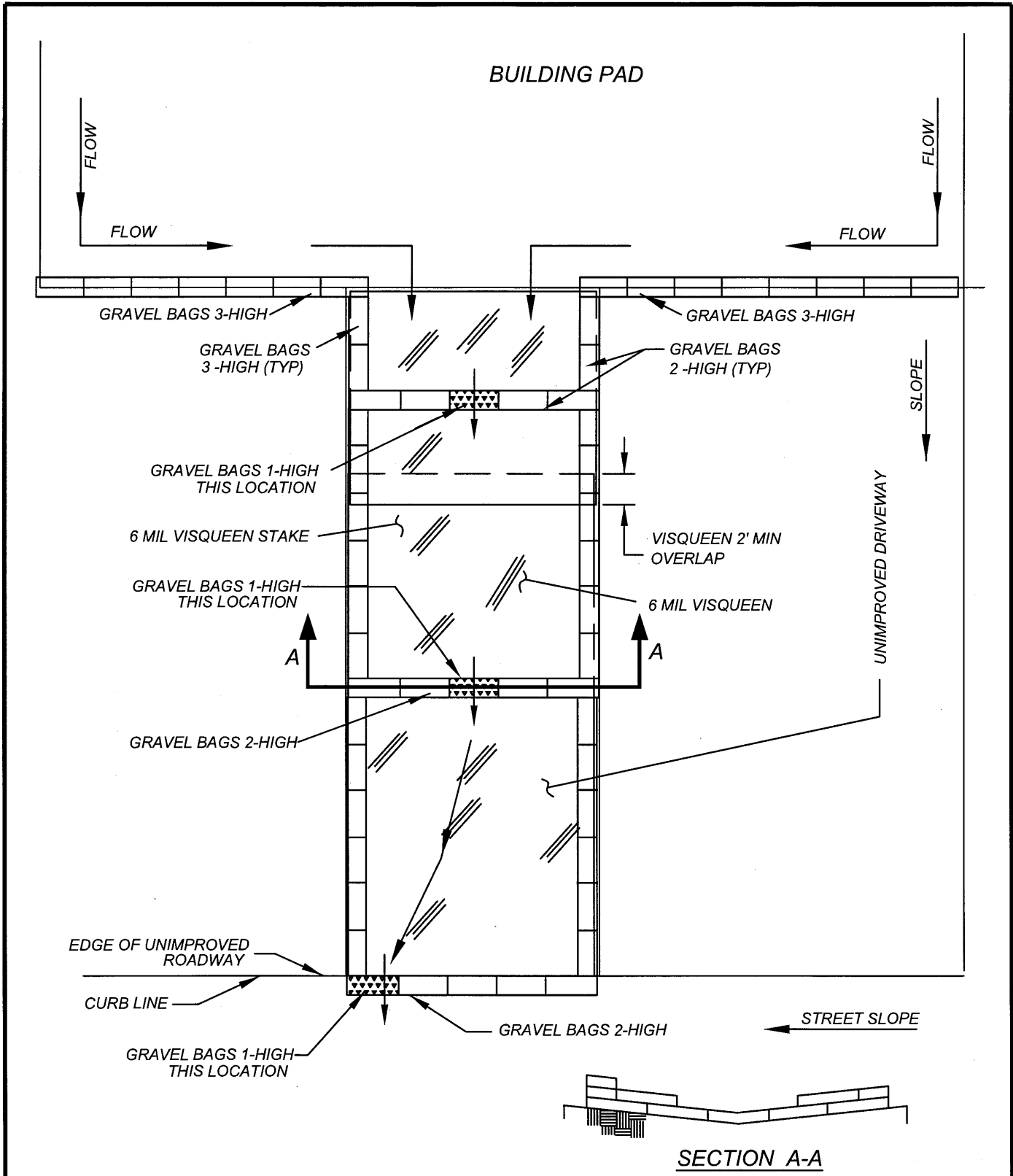

NOT TO SCALE

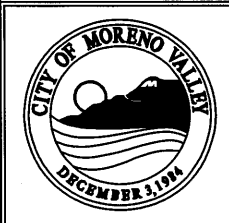

RECOMMENDED:  
*[Signature]* 12/11/17  
 DIVISION MANAGER DATE  
 APPROVED:  
*[Signature]* 9/24/18  
 PUBLIC WORKS DIRECTOR / DATE  
 CITY ENGINEER

**CITY OF MORENO VALLEY**  
 PUBLIC WORKS DEPARTMENT - LAND DEVELOPMENT DIVISION

**CONSTRUCTION DRIVEWAY  
 DESILTING BASIN**

STANDARD PLAN  
**MVFE-351E-0**  
 SHEET 5 OF 6

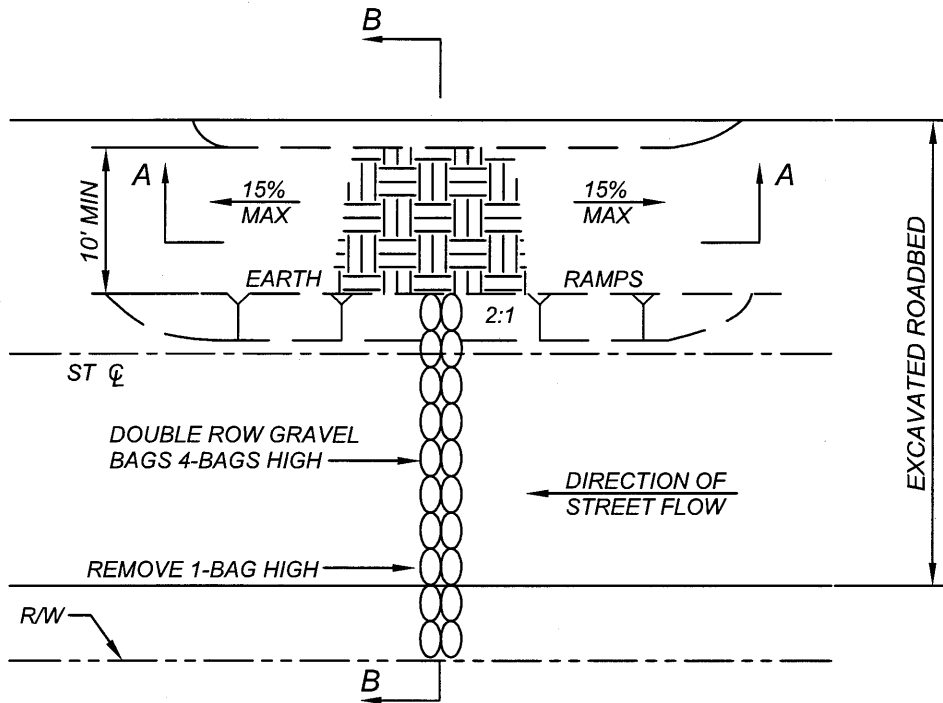

**PLAN**

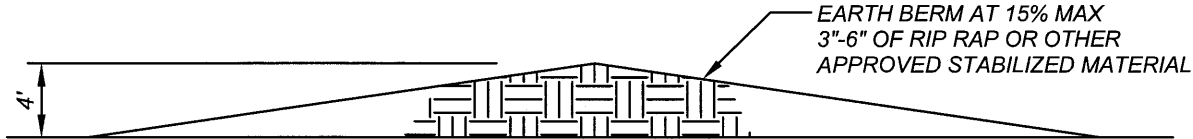

**SECTION A-A**

**NOTE:**

1.) THIS TEMPORARY VEHICLE ACCESS RAMP IS TO BE USED WHEN ON-SITE RUN-OFF (DRAINAGE) IS DIRECTED TOWARDS THE ENTRANCE OF THE PROJECT SITE. THE RAMP/DAM DETAIL IS TO PREVENT STORM WATER FROM EXITING THE PROJECT SITE AND PREVENT VEHICLES FROM DAMAGING THE CHECK DAM AREA.

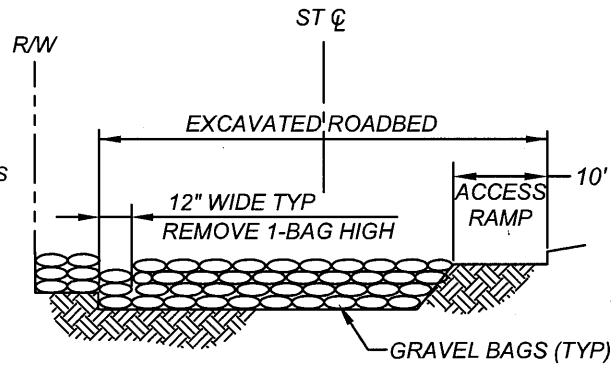

**SECTION B-B**

NOT TO SCALE

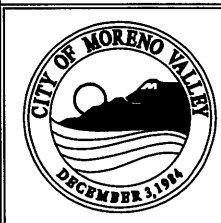

RECOMMENDED:  
*Chad* 12/11/17  
 DIVISION MANAGER DATE  
 APPROVED:  
*MZ. Wref* 9/4/18  
 PUBLIC WORKS DIRECTOR/ DATE  
 CITY ENGINEER

**CITY OF MORENO VALLEY**  
 PUBLIC WORKS DEPARTMENT - LAND DEVELOPMENT DIVISION

**TEMPORARY ACCESS RAMP  
 AND CHECK DAM DETAIL**

STANDARD PLAN  
**MVFE-351F-0**  
 SHEET 6 OF 6



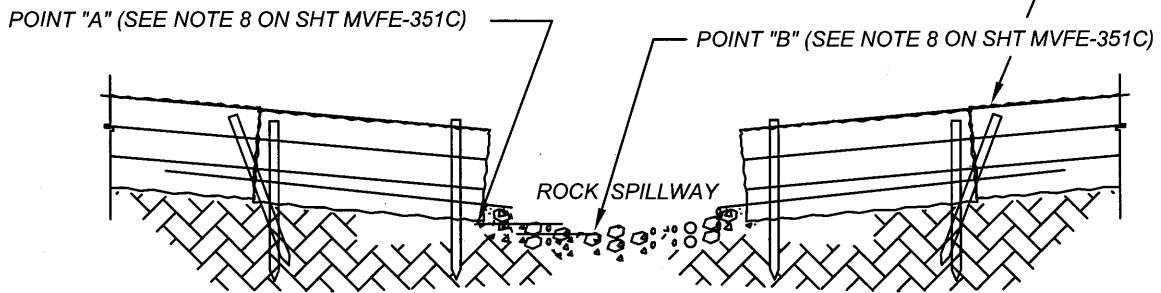
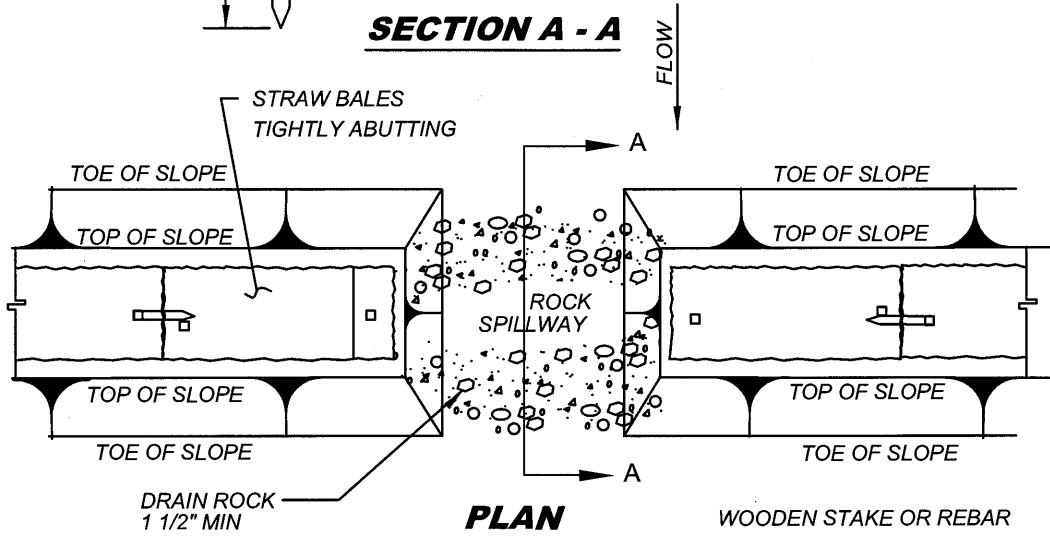
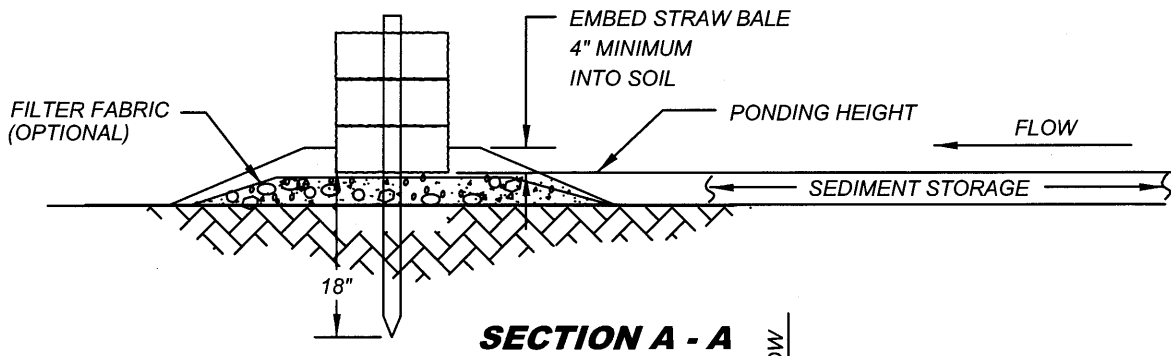

**NOTES:**

- 1.) PLACE BALES PERPENDICULAR TO FLOW.
- 2.) EMBED THE BALES 4" INTO THE SWALE TO PREVENT FLOW AROUND THE BALES.
- 3.) BALES PLACED IN A ROW WITH ENDS TIGHTLY ABUTTING.
- 4.) POINT "A" SHALL BE HIGHER THAN POINT "B".
- 5.) SPILLWAY HEIGHT SHALL NOT EXCEED 24".
- 6.) SEE EROSION CONTROL NOTES, CITY STANDARD NUMBER MVFE-351C.

NOT TO SCALE



RECOMMENDED:  
*[Signature]* 12/11/17  
 DIVISION MANAGER DATE  
 APPROVED:  
*MZ. wep* 9/24/18  
 PUBLIC WORKS DIRECTOR / DATE  
 CITY ENGINEER

**CITY OF MORENO VALLEY**  
 PUBLIC WORKS DEPARTMENT - LAND DEVELOPMENT DIVISION

**SEMI-PERVIOUS STRAW BALE  
 SEDIMENT BARRIER**

STANDARD PLAN  
**MVFE-352-0**

SHEET 1 OF 1

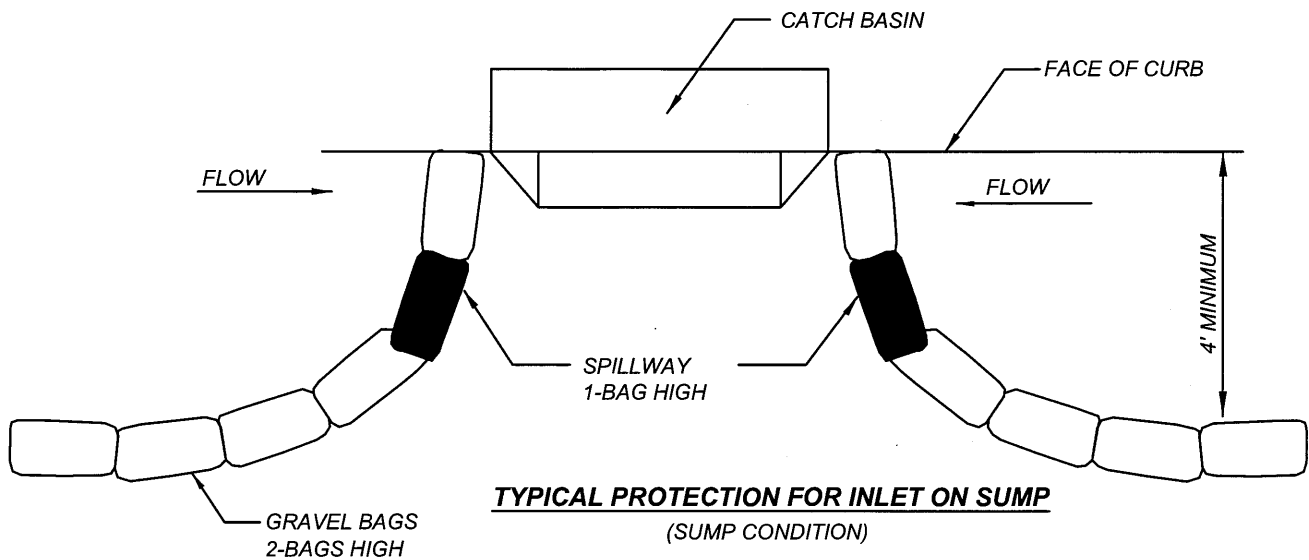

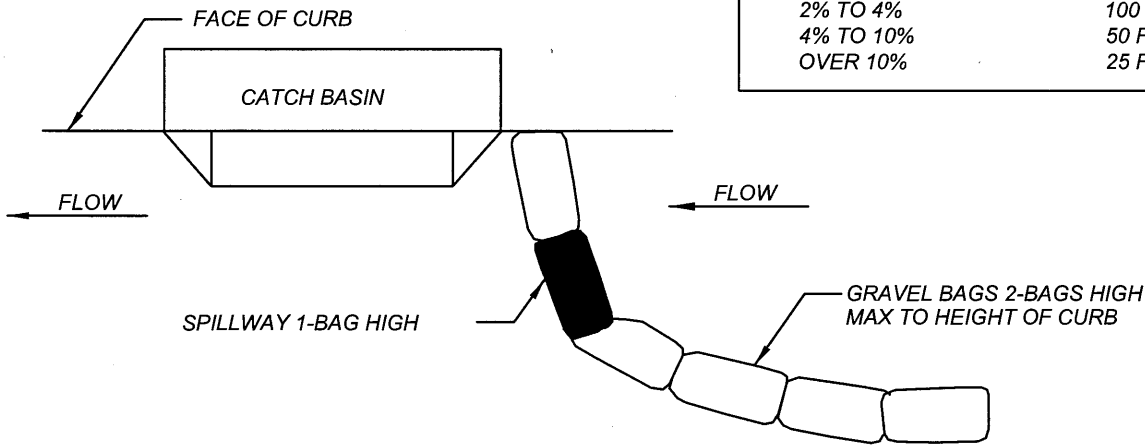

<u>GRADE OF STREET</u>	<u>INTERVAL</u>
LESS THAN 2%	AS REQUIRED
2% TO 4%	100 FEET
4% TO 10%	50 FEET
OVER 10%	25 FEET



**NOTES:**

- 1.) PLACE CURB TYPE SEDIMENT BARRIERS ON GENTLY SLOPING STREET SEGMENTS WHERE WATER CAN POND AND ALLOW SEDIMENT TO SEPARATE FROM RUNOFF.
- 2.) GRAVEL BAGS, OF EITHER BURLAP OR WOVEN GEOTEXTILE FABRIC, ARE FILLED WITH GRAVEL, LAYERED AND PACKED TIGHTLY.
- 3.) LEAVE ONE GRAVEL BAG GAP IN THE TOP ROW TO PROVIDE A SPILLWAY FOR OVERFLOW.
- 4.) INSPECT BARRIERS AND REMOVE SEDIMENT AFTER EACH STORM EVENT. SEDIMENT AND GRAVEL MUST BE REMOVED FROM THE TRAVEL WAY IMMEDIATELY.
- 5.) PROVIDE VELOCITY CHECK DAMS IN ALL UNPAVED STREET AREAS AT THE INTERVALS INDICATED (SEE CHART).
- 6.) SEE EROSION CONTROL NOTES, CITY STD No MVFE-351A & MVFE-351B.

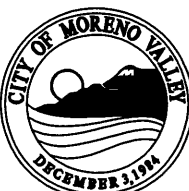
NOT TO SCALE

	RECOMMENDED:  DIVISION MANAGER DATE: 12/11/17	<h2 style="margin: 0;">CITY OF MORENO VALLEY</h2> <p style="margin: 0;">PUBLIC WORKS DEPARTMENT - LAND DEVELOPMENT DIVISION</p>	
	APPROVED:  PUBLIC WORKS DIRECTOR/ CITY ENGINEER DATE: 9/14/18	<h3 style="margin: 0;">TEMPORARY DESILTING MEASURES AT CATCH BASIN</h3>	

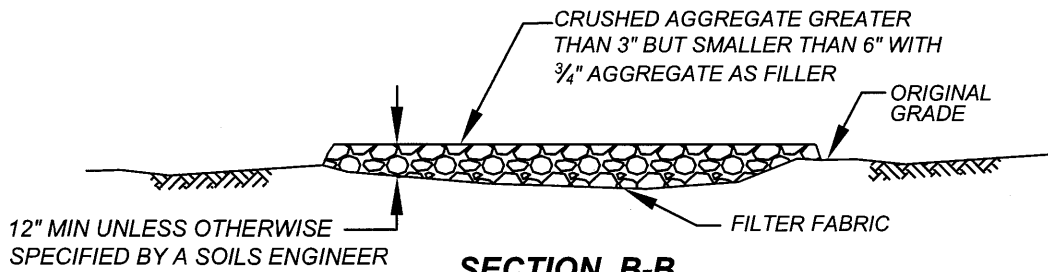

**SECTION B-B**

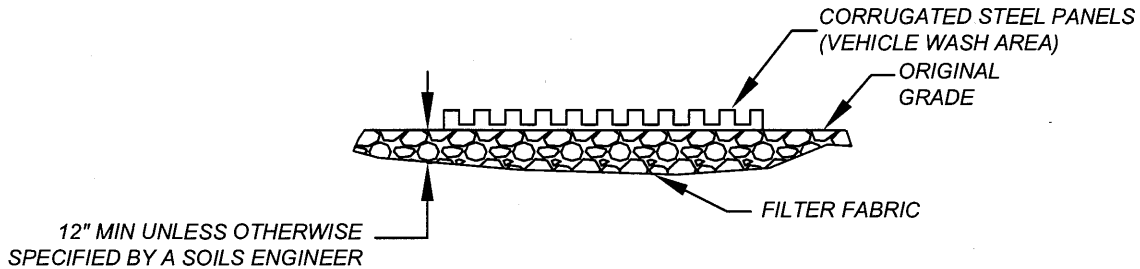

**SECTION A-A**

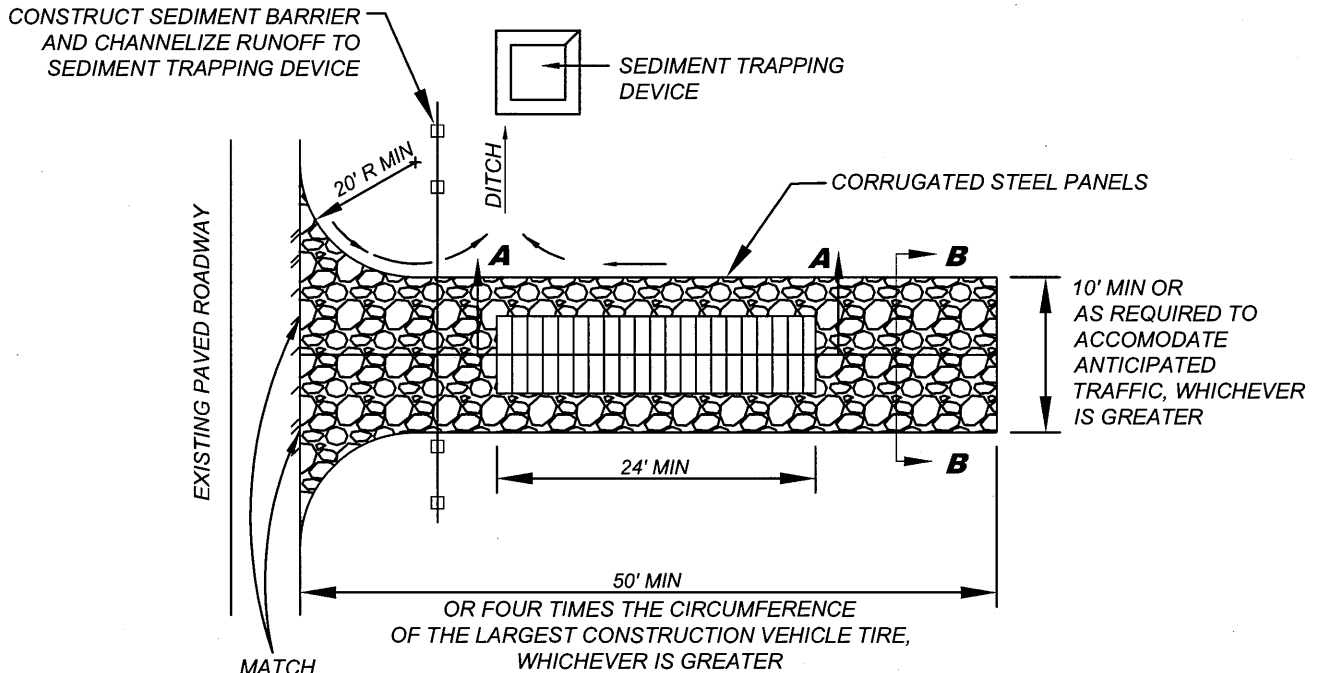

**PLAN**

**NOTES:**

- 1.) ALL CONSTRUCTION EQUIPMENT / PERSONNEL VEHICLES LEAVING THE CONSTRUCTION SITE SHALL BE WASHED DOWN TO REMOVE ALL MUD FROM VEHICLE PRIOR TO ENTERING THE PUBLIC RIGHT-OF-WAY, AS NEEDED.
- 2.) DIMENSIONS SHOWN ABOVE MAY BE ALTERED BY CITY STAFF IN ORDER TO ACHIEVE EFFECTIVENESS.

NOT TO SCALE



RECOMMENDED:  
*[Signature]* 12/11/17  
 DIVISION MANAGER DATE

APPROVED:  
*[Signature]* 9/19/18  
 PUBLIC WORKS DIRECTOR / DATE  
 CITY ENGINEER

**CITY OF MORENO VALLEY**  
 PUBLIC WORKS DEPARTMENT - LAND DEVELOPMENT DIVISION

**STABILIZED CONSTRUCTION  
 EXIT  
 SEDIMENT REMOVAL**

STANDARD PLAN  
**MVFE-354-0**

SHEET 1 OF 1





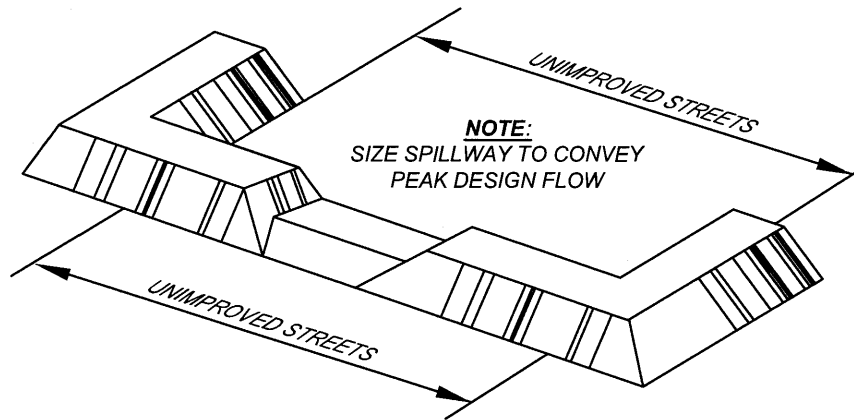

**TYPICAL OPEN SPILLWAY**

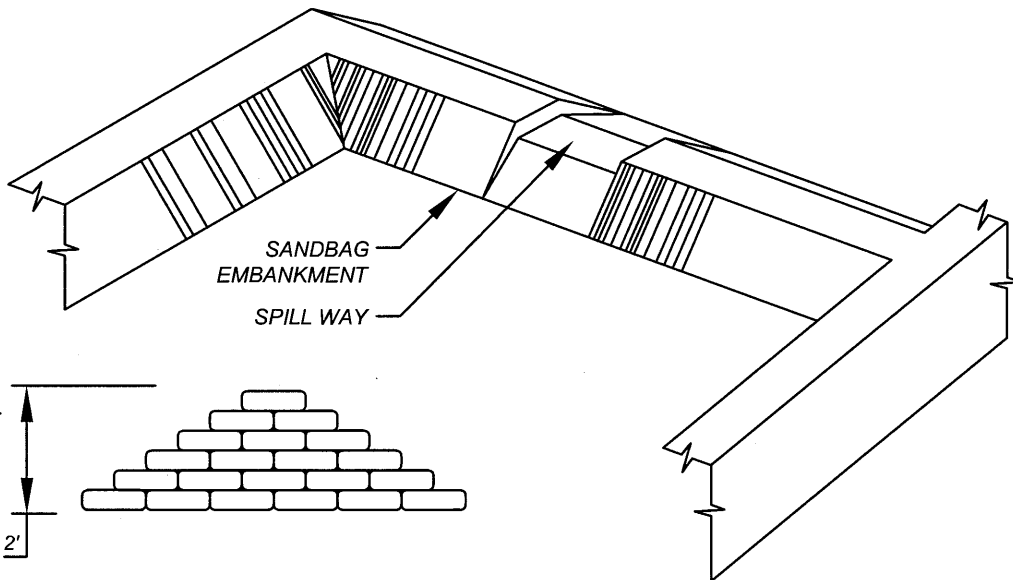

**TYPICAL SANDBAG STACK**  
FOR SPILLWAY APPLICATION

**NOTES:**

- 1.) INSPECT DESILTING BASIN PRIOR TO FORECAST RAIN, DAILY DURING EXTENDED RAIN EVENTS, AFTER RAIN EVENTS, WEEKLY DURING THE RAINY SEASON, AND AT TWO-WEEK INTERVALS DURING THE NON-RAINY SEASON.
- 2.) SANDBAGS EXPOSED TO SUNLIGHT WILL NEED TO BE REPLACED EVERY TWO TO THREE MONTHS DUE TO DEGRADATION OF THE BAGS.
- 3.) RESHAPE OR REPLACE SANDBAGS AS NEEDED.
- 4.) REPAIR WASHOUTS OR OTHER DAMAGE AS NEEDED.
- 5.) SEDIMENT THAT ACCUMULATES IN THE BASIN SHALL BE PERIODICALLY REMOVED IN ORDER TO MAINTAIN EFFECTIVENESS. SEDIMENT SHALL BE REMOVED WHEN THE SEDIMENT ACCUMULATION REACHES ONE-THIRD OF THE BARRIER HEIGHT. SEDIMENT REMOVED DURING MAINTENANCE MAY BE INCORPORATED INTO EARTHWORK ON THE SITE IF APPROVED BY SOIL ENGINEER, OR DISPOSED AT AN APPROPRIATE LOCATION.

NOT TO SCALE

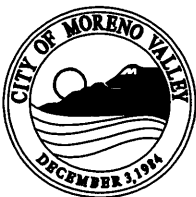

RECOMMENDED:

*[Signature]* 12/11/17  
DIVISION MANAGER DATE

APPROVED:

*[Signature]* 9/14/18  
PUBLIC WORKS DIRECTOR / DATE  
CITY ENGINEER

**CITY OF MORENO VALLEY**  
PUBLIC WORKS DEPARTMENT - LAND DEVELOPMENT DIVISION

**DESILTING BASIN**

STANDARD PLAN  
**MVFE-356-0**

SHEET 1 OF 1

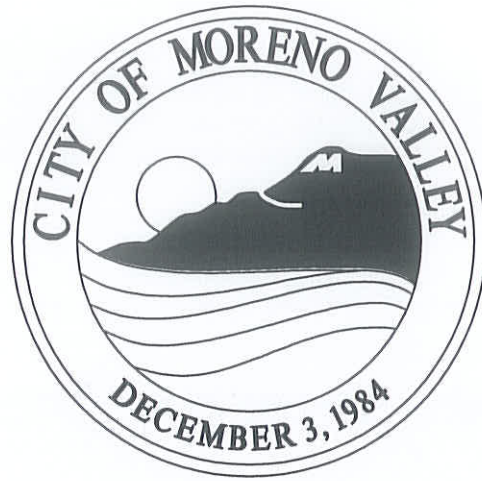

# **CITY OF MORENO VALLEY STANDARD PLANS**

## **SECTION 4**

# STREET LIGHT AND TRAFFIC

*Note: Various State's Standards for Street Light and Traffic may be used subject to review and approval from the Public Works Director/City Engineer.*

# City of Moreno Valley

## Standard Plans Index - 2022 Edition

---

### **SECTION 4: Street Light and Traffic**

#### Street Light

MVLT-400A-3	<i>Residential and Collector Lighting</i>
MVLT-400B-2	<i>Arterial Highway Lighting (Wireless Equipment Capable)</i>
MVLT-400C-0	<i>Arterial Highway Lighting</i>

#### Traffic

MVLT-410A-0	<i>Street Name Sign</i>
MVLT-410B-0	<i>Street Name Sign Abbreviations</i>
MVLT-410C-1	<i>Street Name Sign Specifications</i>
MVLT-410D-0	<i>Street Name Sign Placement</i>
MVLT-410E-0	<i>Street Name Sign Location</i>
MVLT-411A-0	<i>Internally Illuminated Street Name Sign</i>
MVLT-411B-1	<i>Internally Illuminated Street Name Sign Specifications</i>
MVLT-411C-1	<i>Internally / Retrofit Illuminated Street Name Sign Specifications</i>
MVLT-411D-0	<i>Mounting Assembly – Illuminated Street Name Sign Specifications</i>
MVLT-411E-0	<i>Structural Support for Various Luminaires on Type 1-A Pole</i>
MVLT-412-0	<i>Stop Sign Installation</i>
MVLT-413-0	<i>Marbelite Sign Installation</i>
MVLT-414A-0	<i>Sign Post Installation</i>
MVLT-414B-1	<i>Sign Post Installation Notes</i>
MVLT-414C-0	<i>Sign Post Block Out</i>
MVLT-415A-0	<i>Project Sign (Road Work)</i>
MVLT-415B-0	<i>Project Sign (Other Agencies)</i>
MVLT-415C-0	<i>Project Sign (Project Completion)</i>
MVLT-416A-0	<i>End of Road Treatment</i>
MVLT-416B-0	<i>End of Road Treatment Details</i>
MVLT-417-0	<i>Object Markers</i>
MVLT-418A-0	<i>Delineators</i>
MVLT-418B-0	<i>Delineator Placement</i>
MVLT-419-0	<i>Median Nose Treatment</i>
MVLT-420-0	<i>Street Pole Banner</i>
MVLT-430A-1	<i>Street Striping &amp; Pavement Legend Standards &amp; Specifications</i>
MVLT-430B-0	<i>Street Striping &amp; Pavement Legend Standards &amp; Specifications</i>
MVLT-430C-0	<i>Street Striping &amp; Pavement Legend Standards &amp; Specifications</i>
MVLT-431-1	<i>Stop Bar Legend Placement</i>
MVLT-432-1	<i>Crosswalk Location</i>
MVLT-433-0	<i>Continental Crosswalk and Advance Limit Line Placement</i>
MVLT-440A-0	<i>“Blue Dot” Type 1 Marker Placement Notes</i>
MVLT-440B-0	<i>“Blue Dot” Type 1 Marker Placement Street Intersection &amp; Cul-de-Sac</i>
MVLT-440C-0	<i>“Blue Dot” Type 1 Marker Placement - Divided Street &amp; Street with Turn Lane</i>
MVLT-450A-0	<i>Traffic Induction Loops (Decorative Crosswalk)</i>
MVLT-450B-0	<i>Traffic Induction Loops (Thermoplastic Crosswalk)</i>

# City of Moreno Valley

## Standard Plans Index - 2022 Edition

---

**SECTION 4:      Street Light and Traffic (Continued)**

<i>MVLT-450C-0</i>	<i>Traffic Induction Loops Wiring Details</i>
<i>MVLT-460-0</i>	<i>Type 333 Controller Cabinet Foundation Detail</i>
<i>MVLT-461-0</i>	<i>Dual Meter Traffic Signal Service Foundation</i>

**Note:**      ***Various State's Standards for Street Light and Traffic may be used subject to review and approval from the Public Works Director/City Engineer.***



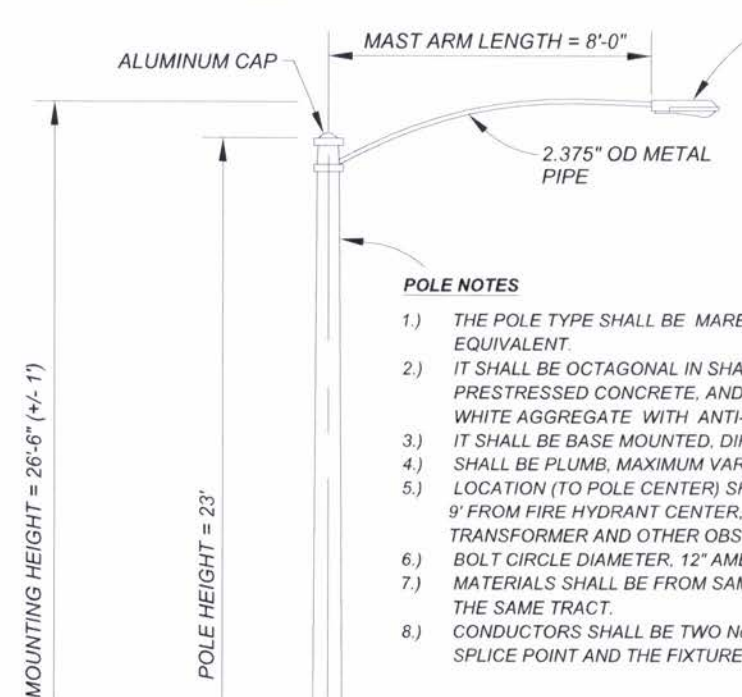

LED (LIGHT EMITTING DIODE) SHALL BE GENERAL ELECTRIC 120/240 V, EVOLVE LED MEDIUM COBRA HEAD WITH AN EVOLVE LIGHT ENGINE CONSISTING OF A NESTED CONCENTRIC AND DIRECTIONAL REFLECTORS, AN IP 65 RATED OPTICAL ENCLOSURE, AND AN INJECTION MOLDED HID ACRYLIC LENS.  
 COLOR TEMPERATURE: 2700 K  
 LUMENS: 3,800  
 WATTS: 29 W  
**ERL1 0 04 B5 27 A GRAY**

**POLE NOTES**

- 1.) THE POLE TYPE SHALL BE MARBELITE, AMERON SERIES 1C1 OR APPROVED EQUIVALENT.
- 2.) IT SHALL BE OCTAGONAL IN SHAPE, SYMMETRICALLY TAPERED, MADE OF PRECAST/PRESTRESSED CONCRETE, AND NATURAL GRAY IN COLOR WITH BLACK AND WHITE AGGREGATE WITH ANTI-GRAFFITI SURFACE.
- 3.) IT SHALL BE BASE MOUNTED, DIRECT BURIAL IS NOT ALLOWED.
- 4.) SHALL BE PLUMB, MAXIMUM VARIANCE 0.08"/FT.
- 5.) LOCATION (TO POLE CENTER) SHALL BE 2'-0" FROM FACE OF CURB, 5' FROM BCR/ECR, 9' FROM FIRE HYDRANT CENTER, 5' FROM DRIVEWAY EDGE, 5' FROM UTILITY TRANSFORMER AND OTHER OBSTRUCTIONS.
- 6.) BOLT CIRCLE DIAMETER, 12" AMERON.
- 7.) MATERIALS SHALL BE FROM SAME MANUFACTURER ALONG SAME STREET AND IN THE SAME TRACT.
- 8.) CONDUCTORS SHALL BE TWO No 8 THW WIRES WITHIN THE POLE BETWEEN THE SPLICE POINT AND THE FIXTURE.

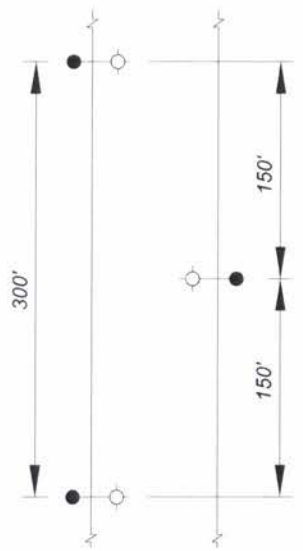
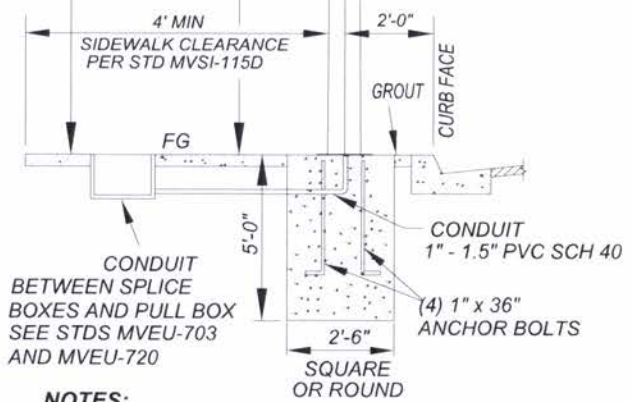

RESIDENTIAL - 3,800 LUMENS

**NOTES:**

- 1.) THE POLE TYPE SHALL BE MARBELITE - AMERON SERIES 1C1 (AMERON DWG No 1807-035) OR APPROVED EQUIVALENT. UTILITY IF THEY ARE IN ACCORDANCE WITH THE NATIONAL STREET LIGHTING GUIDE.
- 2.) LIGHTING SHALL BE PLACED 150' MAX (±20') OR AS APPROVED BY THE CITY ENGINEER) APART ON ALTERNATING SIDES OF THE STREET AND AS NOTED HERE:
  - A) AT THE MIDDLE OF A CUL-DE-SAC.
  - B) AT THE FAR SIDE OF A T-INTERSECTION.
  - C) AT THE END OF A CURB RETURN.
  - D) AT LOCATIONS DETERMINED BY THE CITY TO INCREASE ILLUMINATION.
- 3.) ALL CONCRETE SHALL BE 560-C-3250.
- 4.) THIS STANDARD SHALL APPLY TO STREET CLASSIFICATIONS OF COLLECTOR AND BELOW.
- 5.) FOR IN-FILL CONDITIONS, LIGHTS MAY BE LOCATED TO MATCH EXISTING CONDITIONS.

NOT TO SCALE



RECOMMENDED:  
*Wesun* 10/31/23  
 PRINCIPAL ENGINEER DATE  
 APPROVED:  
*[Signature]* 10/31/23  
 PUBLIC WORKS DIRECTOR DATE  
 CITY ENGINEER

CITY OF MORENO VALLEY  
 PUBLIC WORKS DEPARTMENT - TRANSPORTATION ENGINEERING DIVISION

**RESIDENTIAL & COLLECTOR LIGHTING**

STANDARD PLAN  
**MVLT-400A-3**  
 SHEET 1 OF 3

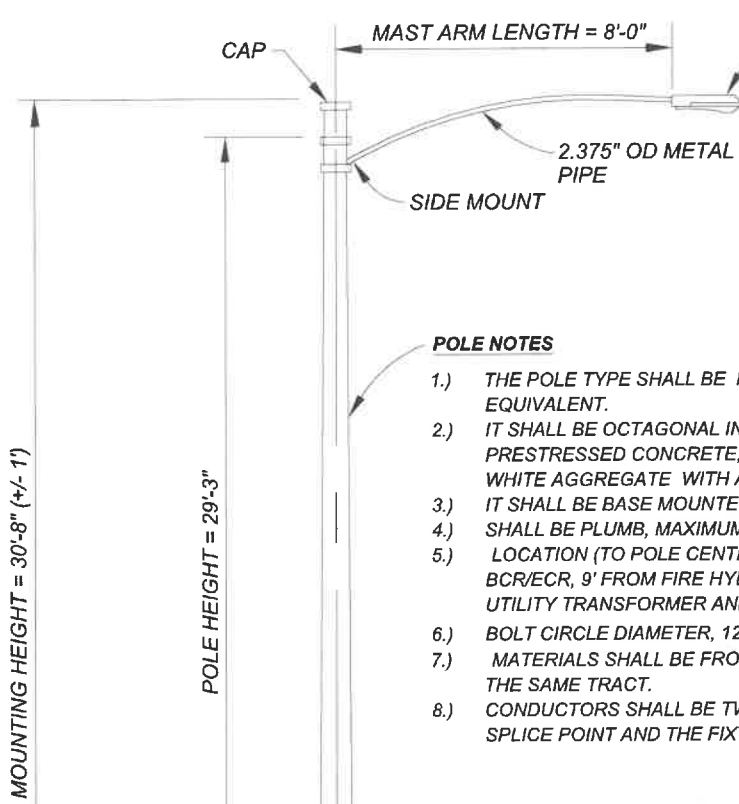

LED (LIGHT EMITTING DIODE) SHALL BE GENERAL ELECTRIC 120/240 V, EVOLVE LED MEDIUM COBRA HEAD WITH AN EVOLVE LIGHT ENGINE CONSISTING OF A NESTED CONCENTRIC AND DIRECTIONAL REFLECTORS, AN IP 65 RATED OPTICAL ENCLOSURE, AND AN INJECTION MOLDED HID ACRYLIC LENS.  
 COLOR TEMPERATURE: 4000 K  
 LUMENS: 11,500  
 WATTS: 98 W  
**ERLH 0 11 B3 40 A GRAY**

**POLE NOTES**

- 1.) THE POLE TYPE SHALL BE MARBELITE, AMERON CBO SERIES OR APPROVED EQUIVALENT.
- 2.) IT SHALL BE OCTAGONAL IN SHAPE, SYMMETRICALLY TAPERED, MADE OF PRECAST/PRESTRESSED CONCRETE, AND NATURAL GRAY IN COLOR WITH BLACK AND WHITE AGGREGATE WITH ANTI-GRAFFITI SURFACE.
- 3.) IT SHALL BE BASE MOUNTED, DIRECT BURIAL IS NOT ALLOWED.
- 4.) SHALL BE PLUMB, MAXIMUM VARIANCE 0.08"/FT.
- 5.) LOCATION (TO POLE CENTER) SHALL BE 2'-0" FROM FACE OF CURB, 5' FROM BCR/ECCR, 9' FROM FIRE HYDRANT CENTER, 5' FROM DRIVEWAY EDGE, 5' FROM UTILITY TRANSFORMER AND OTHER OBSTRUCTIONS.
- 6.) BOLT CIRCLE DIAMETER, 12 1/2" AMERON.
- 7.) MATERIALS SHALL BE FROM SAME MANUFACTURER ALONG SAME STREET AND IN THE SAME TRACT.
- 8.) CONDUCTORS SHALL BE TWO No 8 THW WIRES WITHIN THE POLE BETWEEN THE SPLICE POINT AND THE FIXTURE.

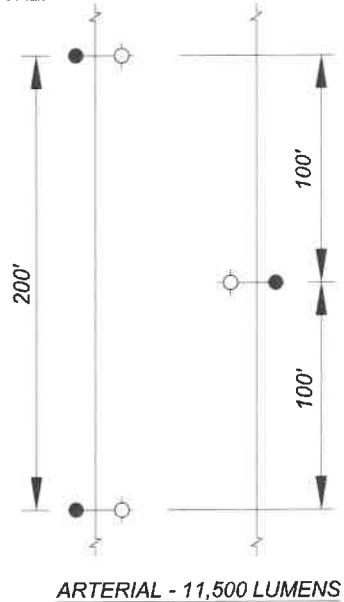
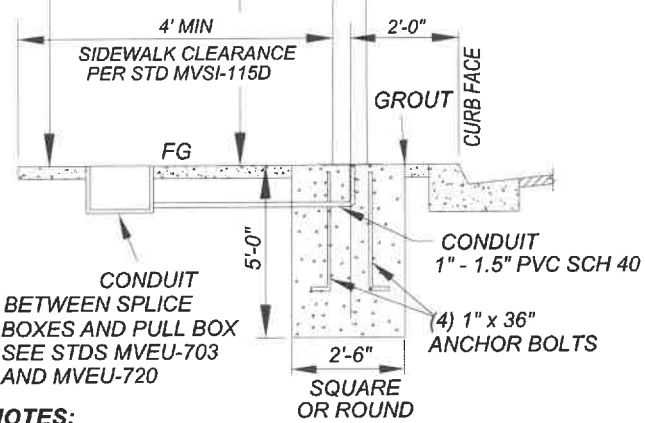

ARTERIAL - 11,500 LUMENS

**NOTES:**

- 1.) THE POLE TYPE SHALL BE MARBELITE - AMERON CBO SERIES (AMERON DWG No 1806-077A) OR APPROVED EQUIVALENT.
- 2.) LIGHTING SHALL BE SPACED 200' MAX (±20') OR AS APPROVED BY THE CITY ENGINEER) DISTANCE APART ON EACH SIDE OF THE STREET.
- 3.) THE CITY MAY REQUIRE ADDITIONAL LIGHTING IN AREAS WHERE INCREASED ILLUMINATION IS DETERMINED TO BE NEEDED.
- 4.) ALL CONCRETE SHALL BE 560-C-3250.
- 5.) THIS STANDARD SHALL APPLY TO STREET CLASSIFICATIONS OF INDUSTRIAL COLLECTOR AND ABOVE.
- 6.) FOR IN-FILL CONDITIONS, LIGHTS MAY BE LOCATED TO MATCH EXISTING CONDITIONS.

NOT TO SCALE



RECOMMENDED:  
*[Signature]* 8/12/20  
 DIVISION MANAGER DATE  
 APPROVED:  
*[Signature]* 8/13/2020  
 PUBLIC WORKS DIRECTOR / DATE  
 CITY ENGINEER

**CITY OF MORENO VALLEY**  
 PUBLIC WORKS DEPARTMENT - TRANSPORTATION ENGINEERING DIVISION

**ARTERIAL HIGHWAY LIGHTING**  
**(WIRELESS EQUIPMENT CAPABLE)**

STANDARD PLAN  
**MVLT-400B-2**  
 SHEET 2 OF 3

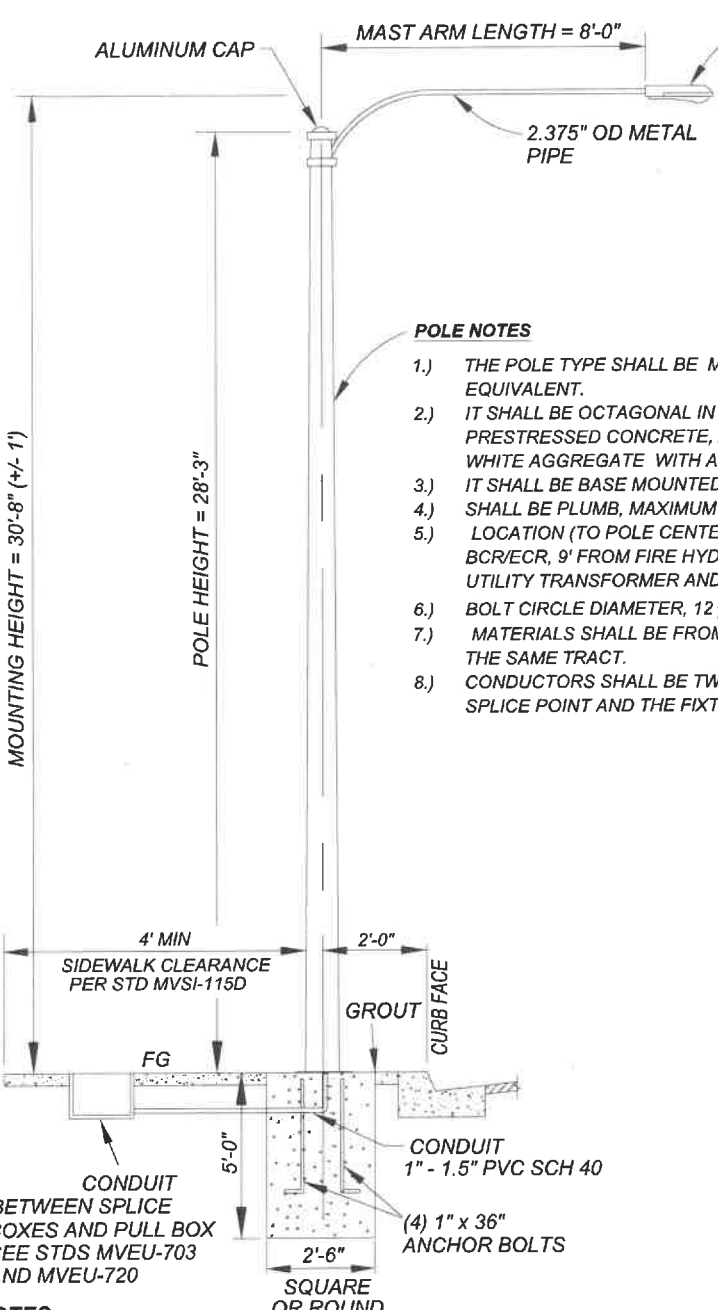

LED (LIGHT EMITTING DIODE) SHALL BE GENERAL ELECTRIC 120/240 V, EVOLVE LED MEDIUM COBRA HEAD WITH AN EVOLVE LIGHT ENGINE CONSISTING OF A NESTED CONCENTRIC AND DIRECTIONAL REFLECTORS, AN IP 65 RATED OPTICAL ENCLOSURE, AND AN INJECTION MOLDED HID ACRYLIC LENS.  
 COLOR TEMPERATURE: 4000 K  
 LUMENS: 11,500  
 WATTS: 98 W  
**ERLH 0 11 B3 40 A GRAY**

**POLE NOTES**

- 1.) THE POLE TYPE SHALL BE MARBELITE, AMERON SERIES 1C1 OR APPROVED EQUIVALENT.
- 2.) IT SHALL BE OCTAGONAL IN SHAPE, SYMMETRICALLY TAPERED, MADE OF PRECAST/PRESTRESSED CONCRETE, AND NATURAL GRAY IN COLOR WITH BLACK AND WHITE AGGREGATE WITH ANTI-GRAFFITI SURFACE.
- 3.) IT SHALL BE BASE MOUNTED, DIRECT BURIAL IS NOT ALLOWED.
- 4.) SHALL BE PLUMB, MAXIMUM VARIANCE 0.08"/FT.
- 5.) LOCATION (TO POLE CENTER) SHALL BE 2'-0" FROM FACE OF CURB, 5' FROM BCR/ECR, 9' FROM FIRE HYDRANT CENTER, 5' FROM DRIVEWAY EDGE, 5' FROM UTILITY TRANSFORMER AND OTHER OBSTRUCTIONS.
- 6.) BOLT CIRCLE DIAMETER, 12 1/2" AMERON.
- 7.) MATERIALS SHALL BE FROM SAME MANUFACTURER ALONG SAME STREET AND IN THE SAME TRACT.
- 8.) CONDUCTORS SHALL BE TWO No 8 THW WIRES WITHIN THE POLE BETWEEN THE SPLICE POINT AND THE FIXTURE.

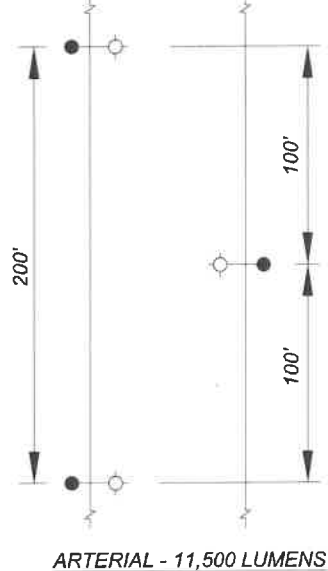

\* PROJECT MAY BE REQUIRED TO PROVIDE STREET LIGHTS / POLES PER CITY STANDARD MVLT-400B AT THE DISCRETION OF THE CITY ENGINEER

**NOTES:**

- 1.) THE POLE TYPE SHALL BE MARBELITE - AMERON SERIES 1C1 (AMERON DWG No 1206-042) OR APPROVED EQUIVALENT.\*
- 2.) LIGHTING SHALL BE SPACED 200' MAX (±20') OR AS APPROVED BY THE CITY ENGINEER) DISTANCE APART ON EACH SIDE OF THE STREET.
- 3.) THE CITY MAY REQUIRE ADDITIONAL LIGHTING IN AREAS WHERE INCREASED ILLUMINATION IS DETERMINED TO BE NEEDED.
- 4.) ALL CONCRETE SHALL BE 560-C-3250.
- 5.) THIS STANDARD SHALL APPLY TO STREET CLASSIFICATIONS OF INDUSTRIAL COLLECTOR AND ABOVE.
- 6.) FOR IN-FILL CONDITIONS, LIGHTS MAY BE LOCATED TO MATCH EXISTING CONDITIONS.

NOT TO SCALE

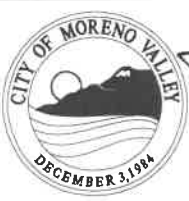

RECOMMENDED:  
*[Signature]* 8/12/20  
 DIVISION MANAGER DATE  
 APPROVED:  
*[Signature]* 8/13/2020  
 PUBLIC WORKS DIRECTOR / DATE  
 CITY ENGINEER

**CITY OF MORENO VALLEY**  
 PUBLIC WORKS DEPARTMENT - TRANSPORTATION ENGINEERING DIVISION

**ARTERIAL HIGHWAY LIGHTING**

STANDARD PLAN  
**MVLT-400C-0**  
 SHEET 3 OF 3

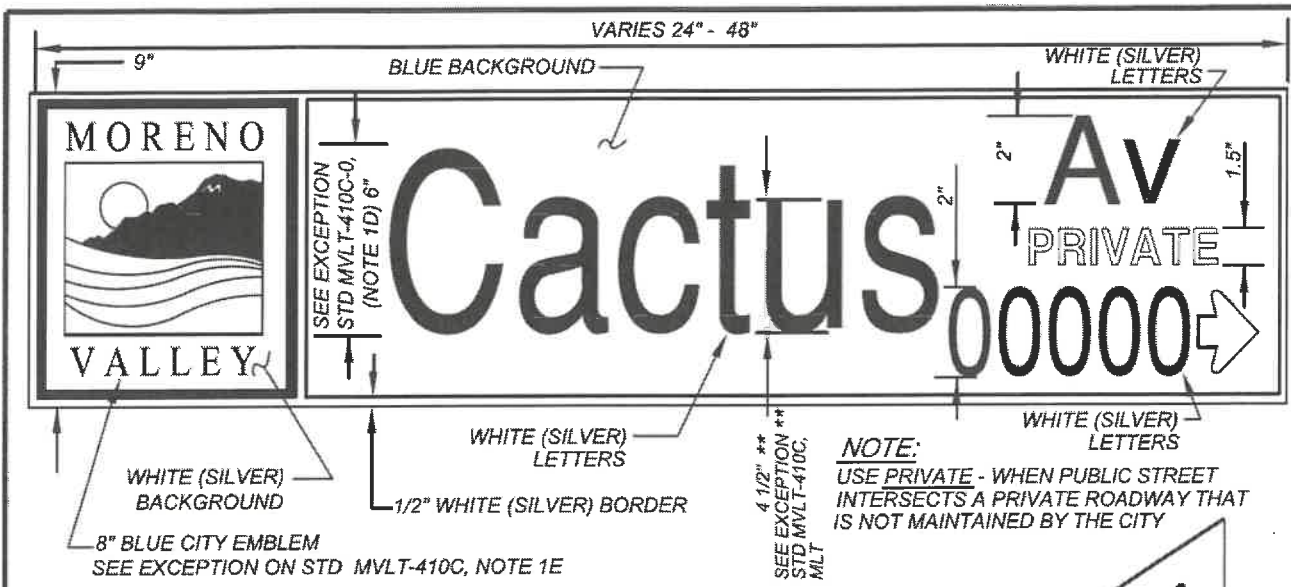

**STANDARD STREET NAME SIGN**



**MODIFIED STREET NAME SIGN**

**NOTE:** FOR INTERSECTING SECONDARY STREETS (LOCAL RESIDENTIAL), USE 5" UPPERCASE AND EQUIVALENT LOWER CASE AND NO CITY EMBLEM. ALL OTHER DIMENSIONS AND INSTALLATION SAME AS STANDARD STREET NAME SIGN. BLOCK NUMBERS ARE NOT SHOWN ON INTERSECTING SECONDARY STREETS

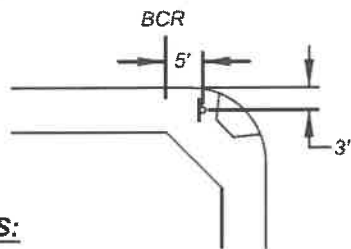

**NOTES:**

- 1.) EACH SIGN POST SHALL ACCOMPANY TWO STREET NAME SIGN BLADES SEE STD MVL-410C FOR COMPLETE STREET NAME SIGN SPECIFICATIONS SEE STD MVL-410D FOR COMPLETE ADDRESS AND ARROW PLACEMENT SEE STD MVL-414A & MVL-414B FOR COMPLETE SIGN POST INSTALLATION BLOCK NUMBERS NOT DISPLAYED ON INTERSECTING SECONDARY STREETS.

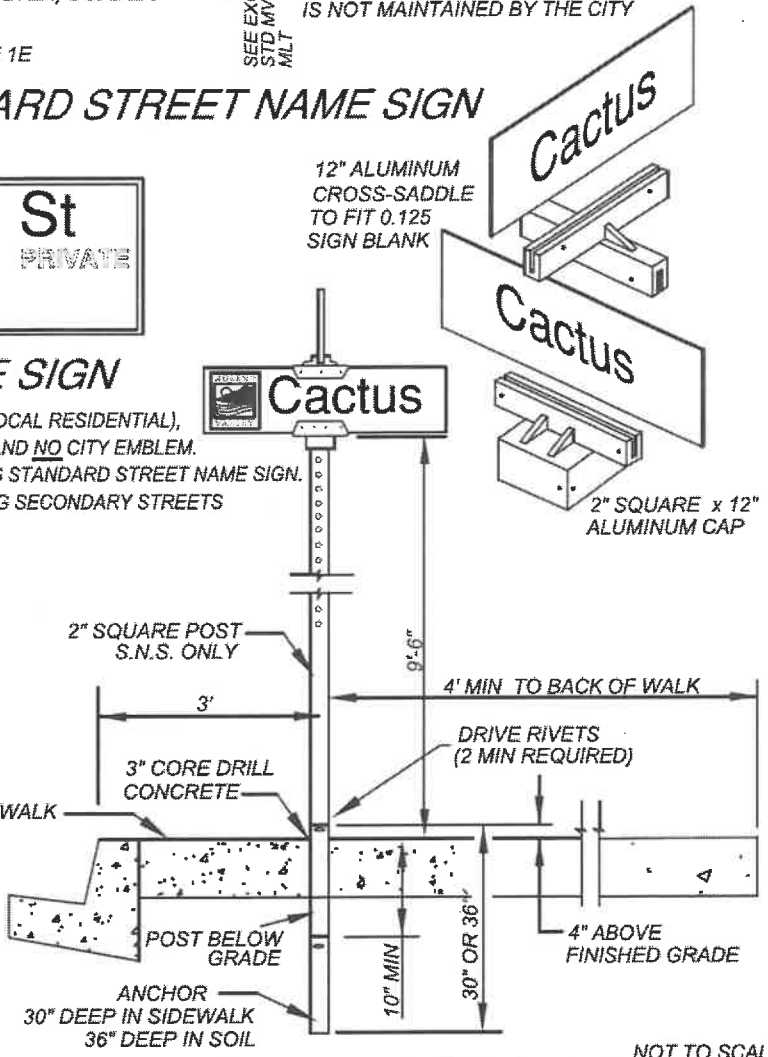

NOT TO SCALE

	RECOMMENDED: <b>EL</b> <b>7/31/19</b> DIVISION MANAGER      DATE	<b>CITY OF MORENO VALLEY</b> PUBLIC WORKS DEPARTMENT - TRANSPORTATION ENGINEERING DIVISION	
	APPROVED: <b>M.L. Welfo</b> <b>7/30/19</b> PUBLIC WORKS DIRECTOR / DATE CITY ENGINEER	<b>STREET NAME SIGN</b>	



**STANDARD ABBREVIATIONS**

ALLEY / ALLY / ALY	AY	LAKE / LAKES	LK
AVENUE / AVE / AVENIDA	AV	LANE	LN
BEACH	BCH	MANOR	MNR
BOULEVARD	BL	MOUNT	MT
BRIDGE	BR	MOUNTAIN	MTN
BROOK	BRK	PARK	PK
CANAL	CNL	PARKWAY	PKWY
CANYON	CYN	PLACE	PL
CENTER	CNTR	PLAZA	PLAZA
CIRCLE	CIR	POINT	PT
COAST	CST	RANCH / RANCHO	RCH
CORNER / CORNERS	COR	RIVER	RV
COURT	CT	ROAD	RD
CREEK	CEK	SPRING / SPRINGS	SPG
DRIVE	DR	SQUARE	SQ
EASTWAY	EWY	STATION	STA
ESTATES	EST	STREET	ST
EXPRESSWAY	EXPWY	SUMMIT	SUM
FIELD / FIELDS	FLD	TERRACE	TER
FORT	FT	TRAIL / TRAILS	TRL
FREEWAY	FWY	VALLEY	VLY
GROVE	GR	VILLAGE	VLG
HEIGHTS	HTS	WALK	WK
HIGHWAY	HWY	WAY	WY
HOME	HM	WESTWAY	WWY
ISLAND / ISLANDS	ISL		
JUNCTION	JCT		

NOT TO SCALE

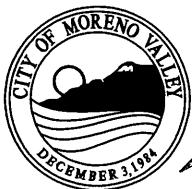

RECOMMENDED:  
**EL**      12/22/16  
 DIVISION MANAGER      DATE

APPROVED:  
 1/20/17  
 PUBLIC WORKS DIRECTOR / DATE  
 CITY ENGINEER

**CITY OF MORENO VALLEY**  
 PUBLIC WORKS DEPARTMENT - TRANSPORTATION ENGINEERING DIVISION

**STREET NAME  
 ABBREVIATIONS**

STANDARD PLAN  
**MVLT-410B-0**  
 SHEET 2 OF 5

**NOTES:**

**1.) SIGN MATERIALS, SIZES AND FABRICATION**

- A.) SIGN BLANK MUST BE 0.125 THICK ALUMINUM, 5052-H38 ALUMINUM ALLOY.
- B.) SIGN BLANK DIMENSIONS ARE 9" HIGH BY A MINIMUM OF 24" TO MAXIMUM OF 48" LONG AS REQUIRED
- C.) SIGN SHEETING MUST BE HIGH PERFORMANCE WIDE ANGLE PRISMATIC LENS REFLECTIVE WHITE (SILVER) SHEETING (3M SCOTCHLITE DIAMOND GRADE VIP 3990) . THE BACKGROUND MUST BE SCREEN PRINTED BLUE USING REFLECTIVE SHEETING MANUFACTURER MATCH COMPONENT INK (3M 8831).
- D.) SIGN STREET NAME LETTERS MUST BE WHITE (SILVER) FHWA (FEDERAL HIGHWAY ADMINISTRATION) SERIES C-6" UPPER CASE AND 4 1/2" LOWER CASE. ADDRESS BLOCK NUMBERS MUST BE WHITE (SILVER) FHWA SERIES C-2" STREET NAME SUFFIX MUST BE WHITE (SILVER) FHWA 2" UPPER CASE AND 1.5" LOWER CASE.  
EXCEPTION: INTERSECTING SECONDARY STREETS USE 5" UPPER CASE AND EQUIVALENT LOWER CASE STREET NAME LETTERS.
- E.) THE LETTER SIZING AND SPACING MUST MEET FHWA SPACING GUIDELINES. MINOR VARIATIONS AS APPROVED BY THE CITY ENGINEER.
- F.) THE CITY EMBLEM MUST BE A BLUE GRAPHIC ON A WHITE (SILVER) BACKGROUND.  
EXCEPTION: NO CITY EMBLEM REQUIRED FOR INTERSECTING SECONDARY STREETS.
- G.) STREET NAME MUST APPEAR ON EACH SIDE OF THE SIGN BLANK.
- H.) STREET NAME SIGN MAY BE FABRICATED USING REFLECTIVE SHEETING MANUFACTURED MATCHED COMPONENT ELECTRONIC CUTTABLE FILMS (3M E.C. 1175).
- I.) SLIGHT LAYOUT VARIATIONS ARE PERMITTED AND MUST BE APPROVED BY THE CITY ENGINEER.
- J.) CERTIFICATES OF COMPLIANCE SHALL BE SUPPLIED FOR ALL SIGNS INSTALLED.

**2.) POST MATERIALS**

- A.) POST MUST BE A TELES PAR 2" SQUARE POST (HOT DIPPED GALVANIZED INSIDE AND OUTSIDE). ALL SIGN POSTS SHALL BE 12 GAUGE STEEL.
- B.) ANCHORS MUST BE TELES PAR 30" OR 36" 2 1/4" SQUARE ANCHORS AND 2 1/2" SLEEVES. ALL ANCHORS AND SLEEVES SHALL BE 12 GAUGE STEEL.
- C.) DRIVE RIVETS MUST BE 3/8" STEEL COATED IN NICKEL, ZINC, OR CHROMIUM TO RESIST RUST (2 RIVETS MINIMUM REQUIRED PER POST / ANCHOR ASSEMBLY).
- D.) ALUMINUM CAP POST BRACKET MUST BE 2" SQUARE CAP WITH 12" SADDLE TO FIT 0.125 SIGN BLANK PER DETAIL MVL-410A-0
- E.) ALUMINUM CROSS SADDLE BRACKET MUST BE 12" SIGN HARDWARE HOLDING BRACKETS. MUST BE MANUFACTURED TO FIT 0.125 SIGN BLADE.



**3.) STREET NAME SIGN PLACEMENT**

- A.) PRIMARY STREET INTERSECTING SECONDARY STREET LOCATE ON PRIMARY STREET - SEE STD MVL-410D-0
- B.) PRIMARY STREET INTERSECTING PRIMARY STREET LOCATE ON NORTHEAST CORNER AND SOUTHWEST CORNER.
- C.) SECONDARY STREET INTERSECTING SECONDARY STREET LOCATE ON NORTHEAST CORNER OR AS APPROVED.

GENERAL NOTES: USE METRIC EQUIVALENTS AS REQUIRED.

COMPLETE TECHNICAL PROVISIONS ARE ON FILE WITH THE TRANSPORTATION ENGINEERING DIVISION.

NOT TO SCALE

	RECOMMENDED: <b>EL</b> DIVISION MANAGER	12/22/16 DATE	<h2 style="margin: 0;">CITY OF MORENO VALLEY</h2> <p style="margin: 0;">PUBLIC WORKS DEPARTMENT - TRANSPORTATION ENGINEERING DIVISION</p>
	APPROVED:  PUBLIC WORKS DIRECTOR / CITY ENGINEER	1/20/17 DATE	<h3 style="margin: 0;">STREET NAME SIGN SPECIFICATIONS</h3>
			SHEET 1 OF 1

Locate secondary street name sign on the bottom

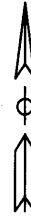
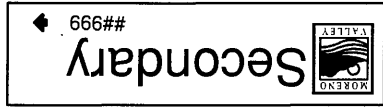

NORTH or EAST  
NOT TO SCALE

Street name sign (SNS) post to be a minimum of 36" from face of curb and 5' out from curb return (SNS ONLY)

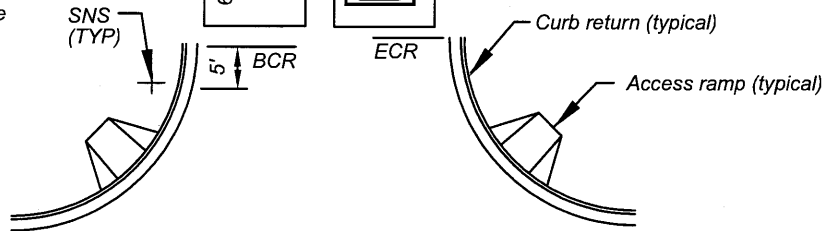

Secondary

Primary

Correct corner location per street classification  
See Standard 400

Use equivalent metric  
Exceptions as approved by City Engineer

Note: Street name signs for intersecting secondary streets do not show address block numbers

Street name signs for intersecting primary and secondary streets, and above, do show address block numbers



Street name post to be a minimum of 36" from face of curb and 5' out from curb return (SNS ONLY)

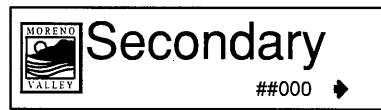
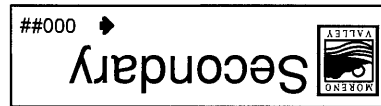

Locate secondary street name sign on the bottom

**NOTES:**

1.) ADDRESS BLOCK NUMBER POINTS IN THE LEADING DIRECTION - INCREASING ADDRESS NUMBERS FOR SOUTH AND EAST (##000➔) AND DECREASING ADDRESS NUMBERS FOR WEST AND NORTH (➔##999).

2.) SEE STD MVL-410E-0 FOR CORRECT CORNER LOCATION BASED ON STREET CLASSIFICATION.

NOT TO SCALE



RECOMMENDED:  
EL 12/22/16  
DIVISION MANAGER DATE  
APPROVED:  
[Signature] 1/20/17  
PUBLIC WORKS DIRECTOR / DATE  
CITY ENGINEER

**CITY OF MORENO VALLEY**

PUBLIC WORKS DEPARTMENT - TRANSPORTATION ENGINEERING DIVISION

**STREET NAME SIGN PLACEMENT**

STANDARD PLAN  
**MVLT-410D-0**

SHEET 4 OF 5

**PRIMARY & PRIMARY INTERSECTION**  
 ALWAYS LOCATE STREET NAME SIGN ON APPROACHING  
 NEARSIDE OF NORTHEAST CORNER AND SOUTHWEST CORNER.  
 EXCEPTIONS AS APPROVED BY CITY ENGINEER

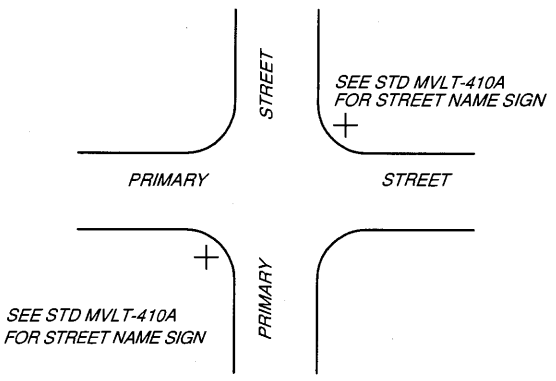

**PRIMARY & SECONDARY INTERSECTION**  
 ALWAYS LOCATE STREET NAME SIGN ON APPROACHING  
 NEARSIDE OF PRIMARY STREET-REGARDLESS OF STREET  
 DIRECTION EXCEPTIONS AS APPROVED BY CITY ENGINEER

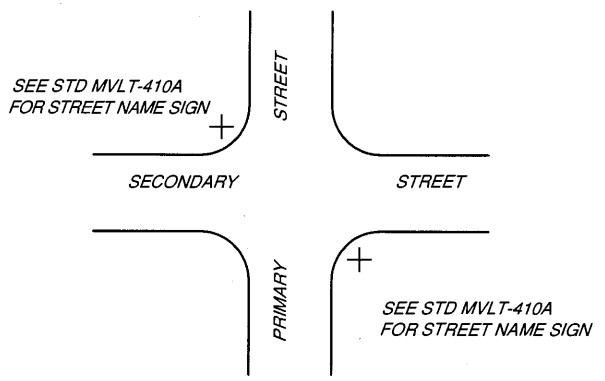

**SECONDARY & SECONDARY INTERSECTION**  
 ALWAYS LOCATE STREET NAME SIGN ON  
 APPROACHING NEARSIDE OF NORTHEAST CORNER.  
 EXCEPTIONS AS APPROVED BY CITY ENGINEER

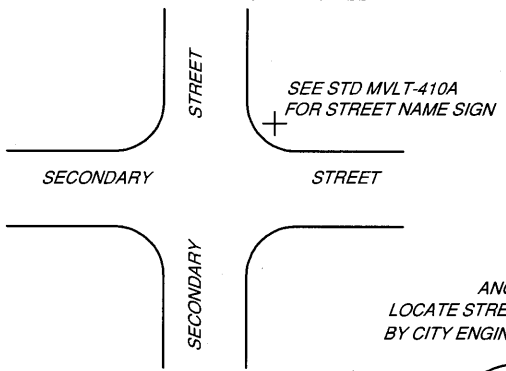

**"T" INTERSECTIONS**  
 ALWAYS LOCATE STREET NAME SIGN ON  
 APPROACHING NEARSIDE OF THROUGH STREET  
 EXCEPTIONS AS APPROVED BY CITY ENGINEER

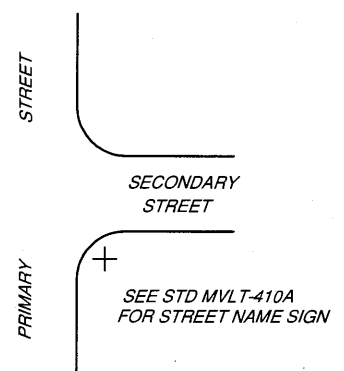

**ANGLED INTERSECTION**  
 LOCATE STREET NAME SIGN AS APPROVED  
 BY CITY ENGINEER

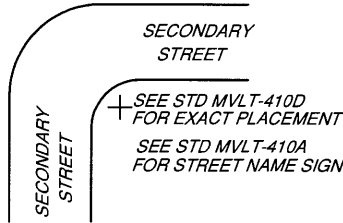

THE TERMS "PRIMARY" AND "SECONDARY" STREETS ARE INTENDED TO DENOTE WHICH STREET IS MORE IMPORTANT: E.G.: (THE WIDER STREET IS THE PRIMARY STREET)

<u>PRIMARY</u>		<u>SECONDARY</u>
ARTERIAL	VS.	COLLECTOR/RESIDENTIAL
COLLECTOR	VS.	LOCAL
LOCAL	VS.	CUL-DE-SAC

AT THE INTERSECTION OF 2 LOCAL STREETS, THE STREET CONSIDERED TO BE THE THROUGH STREET WILL BE BASED ON EXAMINATION OF NEIGHBORHOOD STREET PATTERNS BY THE FIELD ENGINEER.

NOT TO SCALE

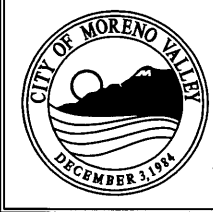

RECOMMENDED:  
**EL**  
 DIVISION MANAGER  
 DATE: 12/22/16

APPROVED:  
  
 PUBLIC WORKS DIRECTOR / DATE: 1/20/17  
 CITY ENGINEER

**CITY OF MORENO VALLEY**  
 PUBLIC WORKS DEPARTMENT - TRANSPORTATION ENGINEERING DIVISION

**STREET NAME SIGN  
 LOCATION**

STANDARD PLAN  
**MVL-410E-0**  
 SHEET 5 OF 5



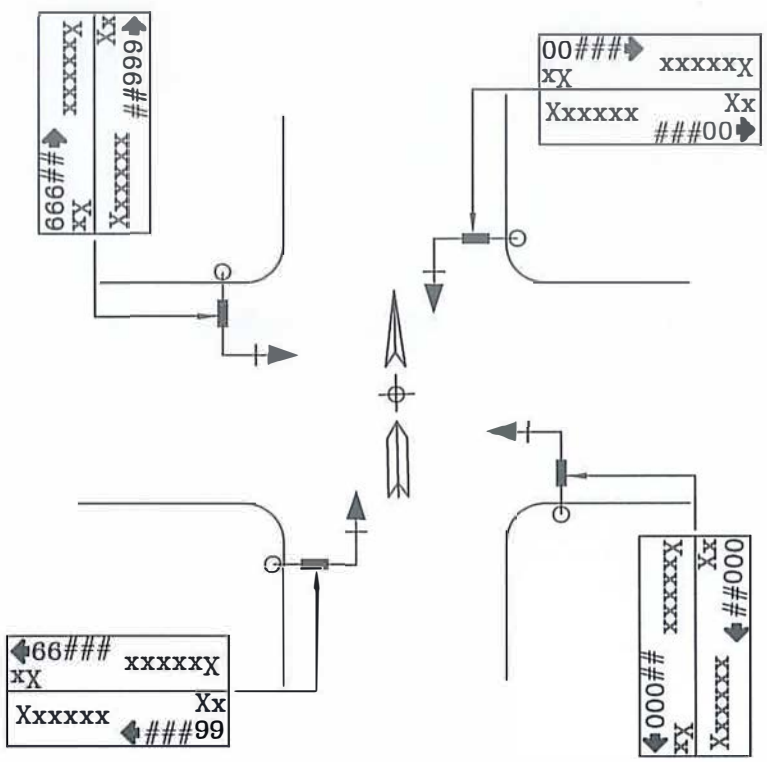

**NEW PANEL:**

**BACKGROUND:**  
 BLUE BACKGROUND WITH WHITE (SILVER) LEGEND AND NUMBERS.

**LETTER STYLE:**  
 FHWA SERIES C

**LETTER SIZE:**  
 STREET NAME.....8" UPPER CASE AND 6" LOWER CASE  
 BLOCK NUMBERS.....4"  
 STREET NAME SUFFIX..4" UPPER CASE AND 3" LOWER CASE

**NOTE:**

- 1.) ALL SPECIFICATIONS SHALL BE PER CALTRANS STANDARD PLAN ES-70 TYPE "A" SIGN EXCEPT AS NOTED ABOVE.
- 2.) SEE STANDARDS MVLT-411B-0, MVLT-411C-0 AND MVLT-411D-0 FOR INTERNALLY ILLUMINATED STREET SIGN SPECIFICATIONS.

NOT TO SCALE

	RECOMMENDED: <div style="display: flex; justify-content: space-between; align-items: center;"> <div style="text-align: center;"> <i>EL</i>            DIVISION MANAGER         </div> <div style="text-align: center;"> <i>1/22/14</i>            DATE         </div> </div>	<h2 style="margin: 0;">CITY OF MORENO VALLEY</h2> <p style="margin: 0;">PUBLIC WORKS DEPARTMENT - TRANSPORTATION ENGINEERING DIVISION</p>
	APPROVED: <div style="display: flex; justify-content: space-between; align-items: center;"> <div style="text-align: center;">             PUBLIC WORKS DIRECTOR /            CITY ENGINEER         </div> <div style="text-align: center;"> <i>1/29/14</i>            DATE         </div> </div>	<h3 style="margin: 0;">INTERNALLY ILLUMINATED STREET NAME SIGN</h3>
SHEET 1 OF 5		

**INTERNALLY ILLUMINATED STREET NAME SIGN**

THE SIGN PANEL, SIZED AS REQUIRED, MUST BE A MINIMUM 0.060 INCH THICK ULTRAVIOLET PROTECTED CLEAR POLYCARBONATE (LEXAN) WITH TRANSLUCENT HIGH PERFORMANCE WIDE ANGLE PRISMATIC LENS REFLECTIVE SHEETING (3M TRANSLUCENT DIAMOND GRADE VIP 3990T OR APPROVED EQUIVALENT).

THE CLEAR LEXAN SIGN PANEL MUST BE COVERED ON ONE SIDE WITH REFLECTIVE SHEETING AND MUST BE SCREEN PRINTED BLUE ON THE SHEETING SIDE USING SHEETING MANUFACTURERS MATCH COMPONENT INK (3M 883i) SO THAT THE LEGENDS ARE WHITE WITH A BLUE BACKGROUND. THE BLUE MUST MATCH THE STANDARD CALTRANS BLUE HIGHWAY GUIDE SIGNS.

THE FINISHED SIGN MUST BE IN CONFORMANCE WITH CITY STD MVL-411 AND HAVE A BLUE BACKGROUND WITH SPECIFIED STREET NAME IN WHITE (SILVER) LEGENDS (LETTERS) AND SPECIFIED NUMBERS IN THE FOLLOWING SIZES:

STREET NAME LETTERS ARE WHITE 8" HIGH UPPERCASE AND WHITE 6" HIGH LOWERCASE.  
 ADDRESS NUMBERS MUST BE WHITE 4" HIGH.  
 STREET SUFFIX MUST BE WHITE 4" HIGH UPPERCASE AND WHITE 3" HIGH LOWERCASE.  
 A 1/2" WHITE BORDER MUST BE VISIBLE WHEN THE SIGN PANEL IS PLACED INSIDE THE FRAME.  
 USE METRIC EQUIVALENTS AS NECESSARY. LOWERCASE LETTERS MAY BE IN PROPORTION TO UPPERCASE LETTERS.

ALL LETTERS AND NUMBERS MUST BE FHWA (FEDERAL HIGHWAY ADMINISTRATION) SERIES C AND MEET CASE REQUIREMENTS AND THE LETTER SPACING MUST MEET FHWA SPACING GUIDELINE. THE ADDRESS BLOCK NUMBER ARROW MUST BE THE STANDARD HIGHWAY TYPE AND POINT IN THE LEADING DIRECTION - INCREASING ADDRESS NUMBERS FOR SOUTH AND EAST (##000➔) AND DECREASING ADDRESS NUMBERS FOR WEST AND NORTH (◆##999).

THE FINISHED SIGN PANEL MUST INCLUDE AND BE INSERTED IN A FRAME AND TOGETHER FIT INTO AN EXISTING TYPE A INTERNALLY ILLUMINATED STREET SIGN NAME SIGN. SEE CALTRANS STANDARD PLAN ES-70.

ALL SPECIFICATIONS MUST MEET CALTRANS STANDARD PLAN ES-70 TYPE A 18" x 72" SIGN EXCEPT AS NOTED. IT IS THE SIGN FABRICATOR'S RESPONSIBILITY TO VERIFY THE DIMENSIONS OR SIZE OF THE EXISTING SIGN PANELS AND SIGN PANEL FRAME BEING REPLACED. SLIGHT VARIATIONS ARE ALLOWED AND MUST BE APPROVED BY THE CITY ENGINEER.

THE LIGHT SOURCE SHALL BE LIGHT EMITTING DIODE (LED) TECHNOLOGY, ILLUMECON LIGHTING EDGE LIT SYSTEM OR AS APPROVED BY THE CITY ENGINEER. THE POWER SUPPLY SHALL INCLUDE A CLASS 2 LED DRIVER WITH A POWER FACTOR OF AT LEAST 99 PERCENT AND TOTAL HARMONIC DISTORTION OF LESS THAN 10 PERCENT, MOUNTED EXTERNALLY FROM THE LED LAMPS, CAPABLE OF BEING MOUNTED TO AN EXISTING BALLAST TRAY. THE LED LAMPS SHALL BE MOUNTED TO A ROTATING DUAL LAMP TUBE HOUSING CONSTRUCTED OF ALUMINUM WITH RECESSED LEDS, SIZE NOT TO EXCEED 5/8" DIAMETER PER LAMP. LAMPS SHALL MOUNT IN ADAPTERS MANUFACTURED TO ACCOMMODATE SLIM LINE, HO, AND BI PIN EXISTING SOCKETS AS REQUIRED.

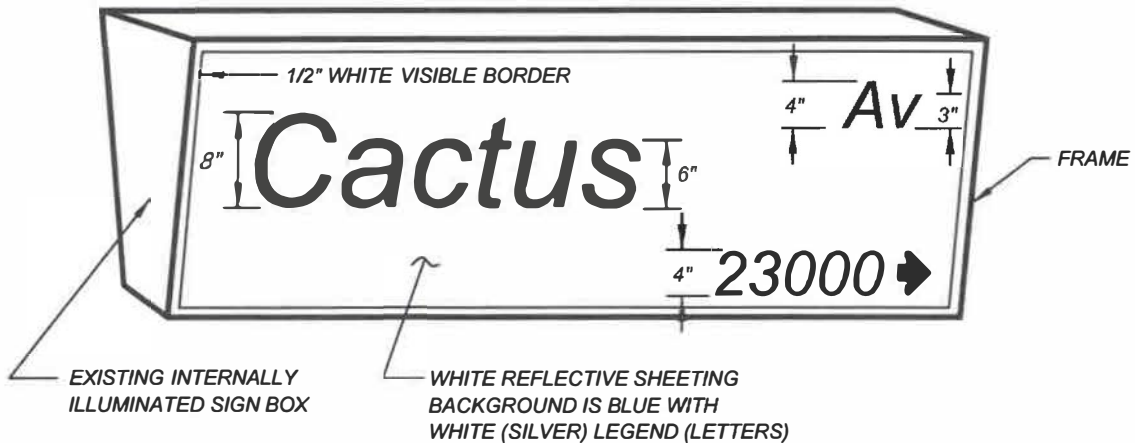

NOT TO SCALE



RECOMMENDED:  
*Wei Sun* 2/1/2022  
 DIVISION MANAGER DATE  
 APPROVED:  
*[Signature]* 2/1/22  
 PUBLIC WORKS DIRECTOR / DATE  
 CITY ENGINEER

**CITY OF MORENO VALLEY**  
 PUBLIC WORKS DEPARTMENT - TRANSPORTATION ENGINEERING DIVISION

**INTERNALLY ILLUMINATED  
 STREET NAME SIGN  
 SPECIFICATIONS**

STANDARD PLAN  
**MVLT-411B-1**  
 SHEET 2 OF 5

**RETROFIT INTERNALLY ILLUMINATED STREET NAME SIGN**

THE SIGN PANEL, SIDE AS REQUIRED, MUST BE A MINIMUM 0.060 INCH THICK ULTRAVIOLET PROTECTED CLEAR POLYCARBONATE (LEXAN) WITH TRANSLUCENT HIGH PERFORMANCE WIDE ANGLE PRISMATIC LENS REFLECTIVE SHEETING (3M TRANSLUCENT DIAMOND GRADE VIP 3990T OR APPROVED EQUIVALENT).

THE CLEAR LEXAN SIGN PANEL MUST BE COVERED ON ONE SIDE WITH REFLECTIVE SHEETING AND MUST BE SCREEN PRINTED BLUE ON THE SHEETING SIDE USING SHEETING MANUFACTURERS MATCH COMPONENT INK (3M 883j) SO THAT THE LEGENDS ARE WHITE WITH A BLUE BACKGROUND. THE BLUE MUST MATCH THE STANDARD CALTRANS BLUE HIGHWAY GUIDE SIGNS.

THE FINISHED SIGN MUST BE IN CONFORMANCE WITH CITY STD MVLT-411 AND HAVE A BLUE BACKGROUND WITH SPECIFIED STREET NAME IN WHITE (SILVER) LEGENDS (LETTERS) AND SPECIFIED NUMBERS IN THE FOLLOWING SIZES:

STREET NAME LETTERS ARE WHITE 8" HIGH UPPERCASE AND WHITE 6" HIGH LOWERCASE.  
 ADDRESS NUMBERS MUST BE WHITE 4" HIGH.  
 STREET SUFFIX MUST BE WHITE 4" HIGH UPPERCASE AND WHITE 3" HIGH LOWERCASE.  
 A 1/2" WHITE BORDER MUST BE VISIBLE WHEN THE SIGN PANEL IS PLACED INSIDE THE FRAME.  
 USE METRIC EQUIVALENTS AS NECESSARY. LOWERCASE LETTERS MAY BE IN PROPORTION TO UPPERCASE LETTERS.

ALL LETTERS AND NUMBERS MUST BE FHWA (FEDERAL HIGHWAY ADMINISTRATION) SERIES C AND MEET CASE REQUIREMENTS AND THE LETTER SPACING MUST MEET FHWA SPACING GUIDELINE. THE ADDRESS BLOCK NUMBER ARROW MUST BE THE STANDARD HIGHWAY TYPE AND POINT IN THE LEADING DIRECTION - INCREASING ADDRESS NUMBERS FOR SOUTH AND EAST (##000➔) AND DECREASING ADDRESS NUMBERS FOR WEST AND NORTH (◆##999).

THE FINISHED SIGN PANEL MUST INCLUDE AND BE INSERTED IN A FRAME AND TOGETHER FIT INTO AN EXISTING TYPE A INTERNALLY ILLUMINATED STREET SIGN NAME SIGN. SEE CALTRANS STANDARD PLAN ES-70.

ALL SPECIFICATIONS MUST MEET CALTRANS STANDARD PLAN ES-70 TYPE A 18" x 72" SIGN EXCEPT AS NOTED. IT IS THE SIGN FABRICATOR'S RESPONSIBILITY TO VERIFY THE DIMENSIONS OR SIZE OF THE EXISTING SIGN PANELS AND SIGN PANEL FRAME BEING REPLACED. SLIGHT VARIATIONS ARE ALLOWED AND MUST BE APPROVED BY THE CITY ENGINEER.

THE LIGHT SOURCE SHALL BE LIGHT EMITTING DIODE (LED) TECHNOLOGY, ILLUMECON LIGHTING EDGE LIT SYSTEM OR AS APPROVED BY THE CITY ENGINEER. THE POWER SUPPLY SHALL INCLUDE A CLASS 2 LED DRIVER WITH A POWER FACTOR OF AT LEAST 99 PERCENT AND TOTAL HARMONIC DISTORTION OF LESS THAN 10 PERCENT, MOUNTED EXTERNALLY FROM THE LED LAMPS, CAPABLE OF BEING MOUNTED TO AN EXISTING BALLAST TRAY. THE LED LAMPS SHALL BE MOUNTED TO A ROTATING DUAL LAMP TUBE HOUSING CONSTRUCTED OF ALUMINUM WITH RECESSED LEDS, SIZE NOT TO EXCEED 5/8" DIAMETER PER LAMP. LAMPS SHALL MOUNT IN ADAPTERS MANUFACTURED TO ACCOMMODATE SLIM LINE, HO, AND BI PIN EXISTING SOCKETS AS REQUIRED.

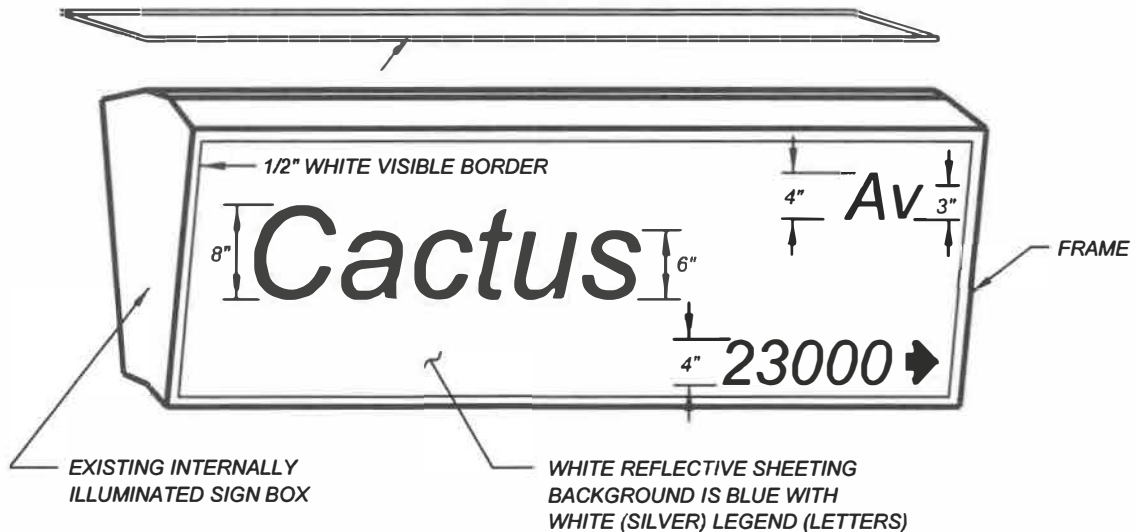

	RECOMMENDED: <i>Wes San</i> 2/1/2022 DIVISION MANAGER / DATE	<b>CITY OF MORENO VALLEY</b> PUBLIC WORKS DEPARTMENT - TRANSPORTATION ENGINEERING DIVISION	
	APPROVED: <i>[Signature]</i> 2/4/22 PUBLIC WORKS DIRECTOR / DATE CITY ENGINEER	<b>INTERNALLY - RETROFIT                  ILLUMINATED STREET NAME                  SIGN SPECIFICATIONS</b>	



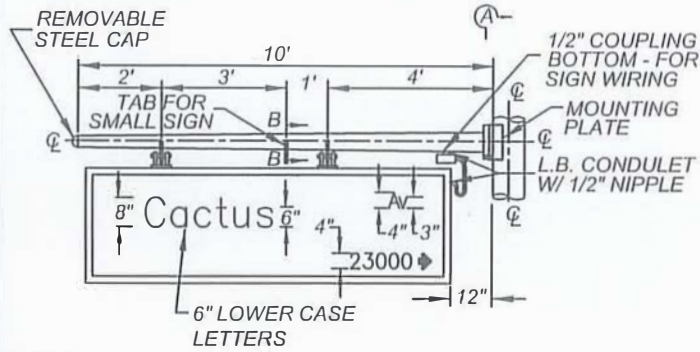

**NOTES FOR MOUNTING ASSEMBLY**

- ① LOWER MOUNTING ASSEMBLY, WITH GASKET.
- ② UPPER MOUNTING ASSEMBLY (TAB).
- ③ BOLT, 1/2", STAINLESS STEEL, WITH SELF-LOCKING NUT.
- ④ FLAT WASHER, STAINLESS STEEL.
- ⑤ BUSHING, BRONZE.
- ⑥ MOUNTING BOLT, 1/4" MINIMUM, WITH NUT AND LOCKWASHER, OR SELF-LOCKING NUT AND COTTER KEY.

**NOTE:**

FOR INTERNALLY ILLUMINATED STREET NAME SIGN, MOUNTING HARDWARE, AND ELECTRICAL DETAILS SEE CITY STD MVL-411B-0 STATE STANDARD ES-70 AND THE SPECIAL PROVISIONS.

**HORIZONTAL MAST ARM**

INSTALL IISNS ON HORIZONTAL MAST ARM 8 FEET ABOVE TOP OF SMA SIMPLEX TO CENTER OF IISNS ARM SIMPLEX. THE MANUFACTURER SHALL PROVIDE CERTIFICATION TO THE CITY THAT THE POLE IS DESIGNED TO ACCOMMODATE THE ADDITIONAL MAST ARM, MOUNTINGS AND INTERNALLY ILLUMINATED STREET NAME SIGN.

**NOTES FOR HORIZONTAL MAST ARM**

ROUND TAPERED STEEL TUBE 0.1793" WITH MAXIMUM TAPER OF 0.14 INCHES PER FOOT AND 5 1/2" OD MAXIMUM AT POLE, ASTM A-36 & 53. IN LIEU OF THE TORQUE REQUIREMENTS FOR HS BOLTS, CAP SCREWS SHALL BE TIGHTENED BY THE TURN-OF-NUT METHOD, 1/3 TURN FROM SNUG TIGHT CONDITION. NO WASHER WILL BE REQUIRED. CALTRANS STANDARD DRAWING ES-6S, DETAIL 'F', FATIGUE RESISTANT WELD, IS REQUIRED AT IISNS ARM PLATE AND POLE BASE PLATE.

**SPECIFICATIONS**

DESIGN: AASHTO SPECIFICATIONS FOR THE DESIGN AND CONSTRUCTION OF STRUCTURAL SUPPORTS FOR HIGHWAY SIGNS, LUMINAIRES AND TRAFFIC SIGNALS, DATED 2004 (4TH EDITION).

WIND LOADINGS: 100 MPH AASHTO

**UNIT STRESSES**

STRUCTURAL STEEL :  $f_y = 331 \text{ MPa}$  (TAPERED SHEET STEEL)  
 $f_y = 248 \text{ MPa}$  UNLESS NOTED OTHERWISE

CONSTRUCTION: STANDARD SPECIFICATIONS AND THE SPECIAL PROVISIONS.

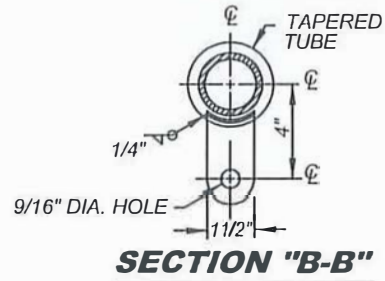
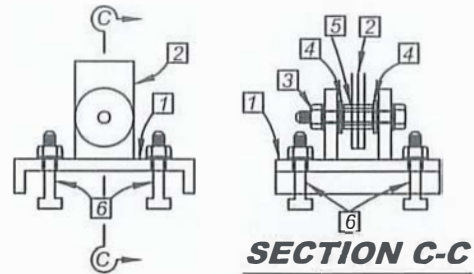

**NOTES:**

- 1. MATERIAL: STEEL OF 48,000 PSI MIN. YIELD AFTER FABRICATION.
- 2. HOT DIP GALVANIZED FINISH. PER ASTM A-123.
- 3. ALL WELDS SHALL CONFORM TO AWS D1.1 SPECIFICATIONS.
- 3. BASE PLATES AND FLANGES SHALL BE PER ASTM A-35 & A-36 STEEL

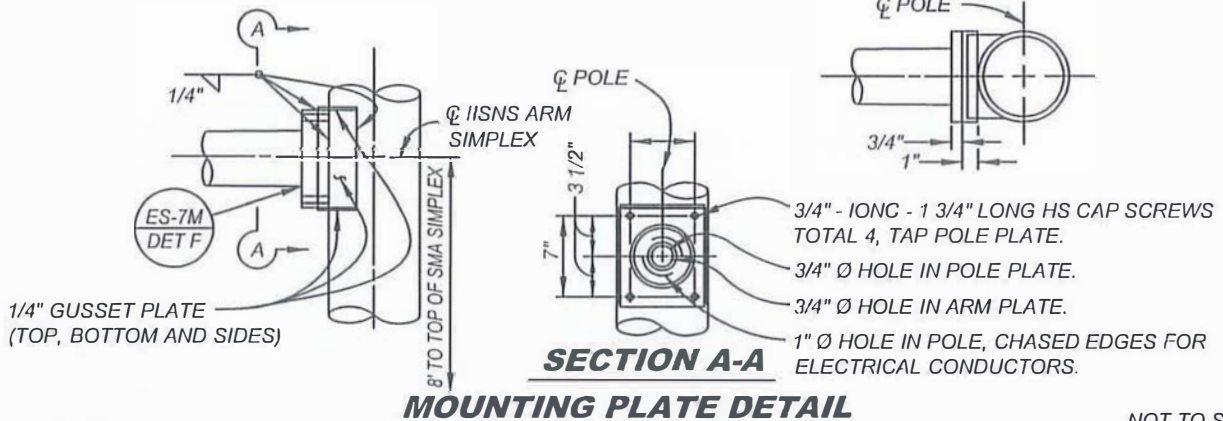

NOT TO SCALE



RECOMMENDED:  
 EL 1/22/14  
 DIVISION MANAGER DATE  
 APPROVED: [Signature] 1/29/14  
 PUBLIC WORKS DIRECTOR / DATE  
 CITY ENGINEER

**CITY OF MORENO VALLEY**  
 PUBLIC WORKS DEPARTMENT - TRANSPORTATION ENGINEERING DIVISION

**MOUNTING ASSEMBLY -  
 ILLUMINATED STREET NAME  
 SIGN SPECIFICATIONS**

STANDARD PLAN  
**MVL-411D-0**  
 SHEET 4 OF 5



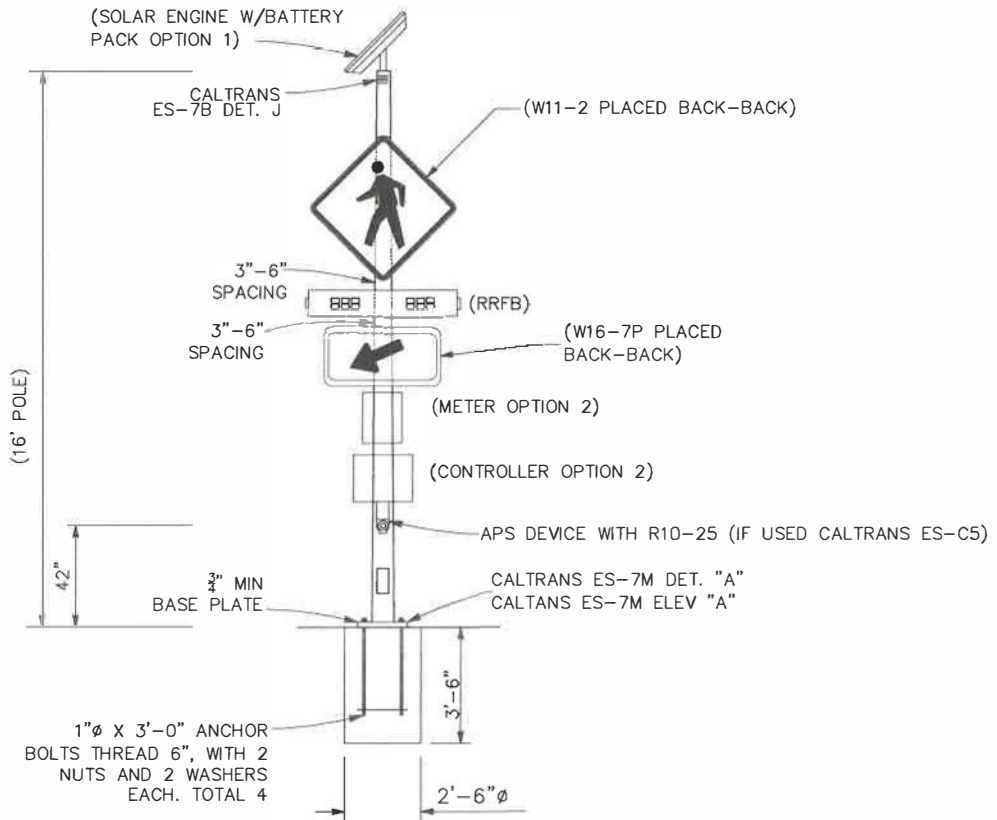

SAMPLE OF A RECTANGULAR RAPID FLASHING BEACON SETUP  
ON TYPE 1-A POLE  
EXHIBIT "A"

**GENERAL NOTES:**

1. INSTALL TYPE 1-A POLE (16' FT ) WITH FOUNDATION PER CALTRANS 2010 STANDARD ES-7B AND CITY STANDARDS (SEE EXHIBIT "A").
2. TYPE 1-A POLE CAN BE USED FOR STRUCTURAL SUPPORTS FOR LUMINAIRES FROM CALTRANS ES-7A THROUGH ES-7L WHICH INCLUDE THE FOLLOWING: TRAFFIC SIGNALS - PEDESTRIAN SIGNALS - STREET NAME SIGNS - LUMINAIRES - PUSH BUTTON ASSEMBLIES - ACCESSIBLE PEDESTRIAN SIGNALS - FLASHING BEACONS - RECTANGULAR RAPID FLASHING BEACONS - SPEED FEEDBACK - CERTAIN ASSOCIATED SIGN PANELS - CERTAIN OTHER MISCELLANEOUS ITEMS.
3. INSTALLATION OF DEVICES ATTACHED TO TYPE 1-A POLE SHALL BE COMPLETED IN ACCORDANCE WITH MANUFACTURE SPECIFICATIONS.
4. DIMENSIONS, MATERIALS, AND ATTACHMENTS WHICH MAY VARY BETWEEN MANUFACTURERS WILL REQUIRE CITY ENGINEER APPROVAL.
5. DESIGN PLANS SHOULD BE CONSULTED FOR VARIATIONS AND APPROVED BY CITY ENGINEER.
6. ALL SIGNS AND DEVICES MUST MEET THE CALIFORNIA MANUAL OF TRAFFIC CONTROL DEVICES GUIDELINES.
7. ANY MODIFICATIONS MADE MUST BE APPROVE BY CITY ENGINEER.
8. MINIMUM SIGN CLEARANCE SHALL BE AT 7FT FROM BASE OF POLE.

NOT TO SCALE

	RECOMMENDED: <i>W. Sun</i> 7/31/2023 DIVISION MANAGER      DATE	<h2 style="margin: 0;">CITY OF MORENO VALLEY</h2> <p style="margin: 0;">PUBLIC WORKS DEPARTMENT - TRANSPORTATION ENGINEERING DIVISION</p>	
	APPROVED: <i>[Signature]</i> 8/19/23 PUBLIC WORKS DIRECTOR / DATE CITY ENGINEER	<h3 style="margin: 0;">STRUCTURAL SUPPORT FOR VARIOUS LUMINAIRES ON TYPE 1-A POLE</h3>	STANDARD PLAN <h2 style="margin: 0;">MVLT-411E-0</h2>
			SHEET 5 OF 5

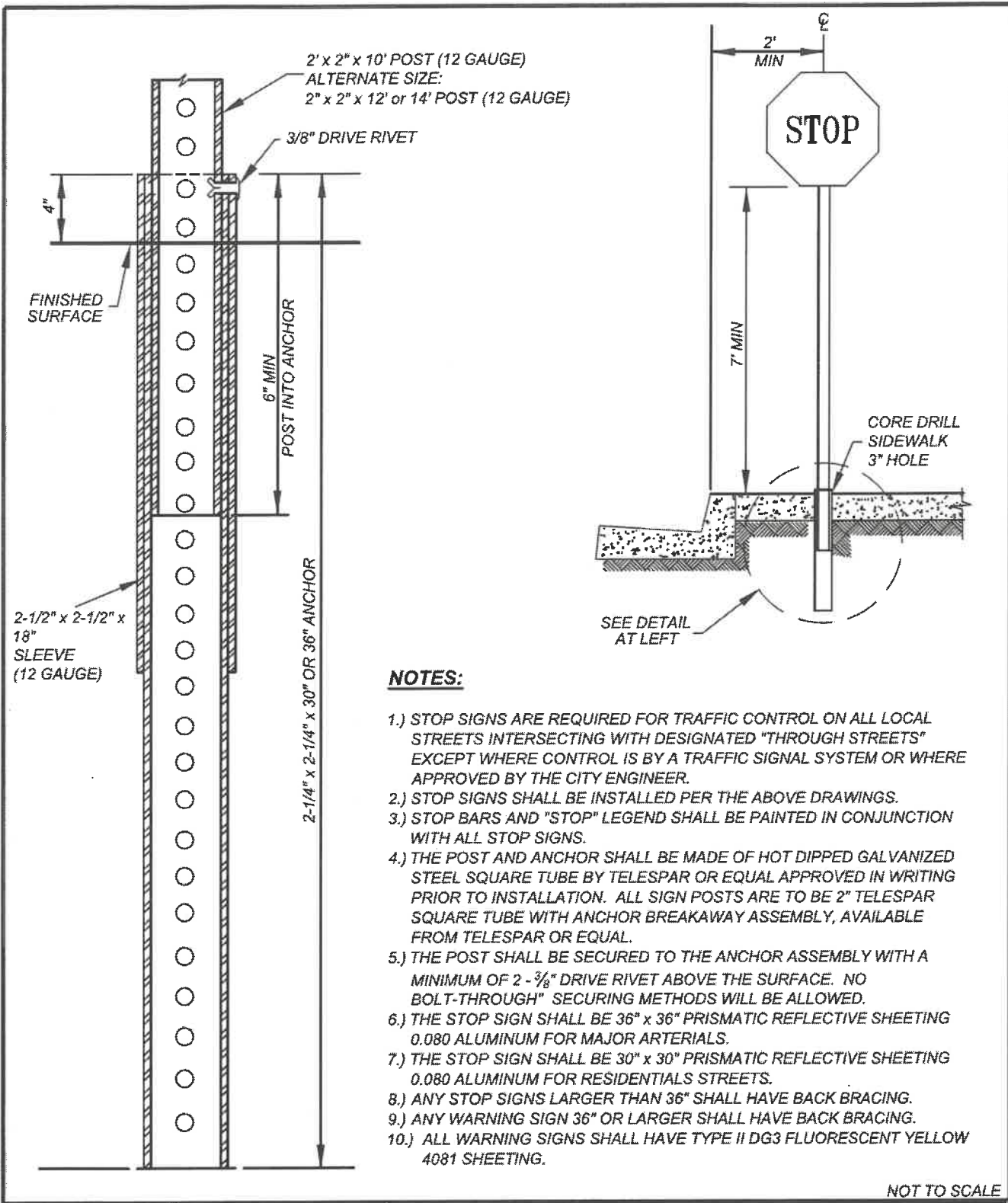

**NOTES:**

- 1.) STOP SIGNS ARE REQUIRED FOR TRAFFIC CONTROL ON ALL LOCAL STREETS INTERSECTING WITH DESIGNATED "THROUGH STREETS" EXCEPT WHERE CONTROL IS BY A TRAFFIC SIGNAL SYSTEM OR WHERE APPROVED BY THE CITY ENGINEER.
- 2.) STOP SIGNS SHALL BE INSTALLED PER THE ABOVE DRAWINGS.
- 3.) STOP BARS AND "STOP" LEGEND SHALL BE PAINTED IN CONJUNCTION WITH ALL STOP SIGNS.
- 4.) THE POST AND ANCHOR SHALL BE MADE OF HOT DIPPED GALVANIZED STEEL SQUARE TUBE BY TELESPAR OR EQUAL APPROVED IN WRITING PRIOR TO INSTALLATION. ALL SIGN POSTS ARE TO BE 2" TELESPAR SQUARE TUBE WITH ANCHOR BREAKAWAY ASSEMBLY, AVAILABLE FROM TELESPAR OR EQUAL.
- 5.) THE POST SHALL BE SECURED TO THE ANCHOR ASSEMBLY WITH A MINIMUM OF 2 - 3/8" DRIVE RIVET ABOVE THE SURFACE. NO "BOLT-THROUGH" SECURING METHODS WILL BE ALLOWED.
- 6.) THE STOP SIGN SHALL BE 36" x 36" PRISMATIC REFLECTIVE SHEETING 0.080 ALUMINUM FOR MAJOR ARTERIALS.
- 7.) THE STOP SIGN SHALL BE 30" x 30" PRISMATIC REFLECTIVE SHEETING 0.080 ALUMINUM FOR RESIDENTIALS STREETS.
- 8.) ANY STOP SIGNS LARGER THAN 36" SHALL HAVE BACK BRACING.
- 9.) ANY WARNING SIGN 36" OR LARGER SHALL HAVE BACK BRACING.
- 10.) ALL WARNING SIGNS SHALL HAVE TYPE II DG3 FLUORESCENT YELLOW 4081 SHEETING.

NOT TO SCALE

	RECOMMENDED: <div style="display: flex; justify-content: space-between; align-items: center;"> <span style="font-size: 1.5em; font-weight: bold;">EL</span> <span style="font-size: 1.5em; font-weight: bold;">7/3/19</span> </div> DIVISION MANAGER      DATE	<h2 style="margin: 0;">CITY OF MORENO VALLEY</h2> <p style="margin: 0;">PUBLIC WORKS DEPARTMENT - TRANSPORTATION ENGINEERING DIVISION</p>
	APPROVED: <div style="display: flex; justify-content: space-between; align-items: center;"> <span style="font-size: 1.5em; font-weight: bold;">MZ. Ward</span> <span style="font-size: 1.5em; font-weight: bold;">7/3/19</span> </div> PUBLIC WORKS DIRECTOR / DATE CITY ENGINEER	<h3 style="margin: 0;">STOP SIGN INSTALLATION</h3>
SHEET 1 OF 2		

- BAND-IT** - C406 OR EQUAL. 316 STAINLESS STEEL  
3/4" WIDTH  
.030" THICKNESS
- BRACKET** - BAND-IT, D001 OR EQUAL. 1 BOLT  
STRAIGHT LEG STAINLESS STEEL.
- BUCKLES** - BAND-IT C456 OR EQUAL. EAR LOCKED  
316 STAINLESS STEEL 3/4".
- BOLTS** - 1" x 5/16" COARSE THREAD STAINLESS STEEL.
- WASHERS** - ALL SIGNS SHALL BE INSTALLED WITH 5/16" ZINC  
COATED WASHERS LARGER THAN THE HEAD OF THE BOLT.  
ANY SIGN 24" OR LARGER SHALL BE INSTALLED WITH  
WASHERS NO LESS THAN 1" OUTSIDE DIAMETER  
ANY SIGN 30" OR LARGER SHALL BE INSTALLED WITH  
WASHERS NO LESS THAN 1-1/2" OUTSIDE DIAMETER  
(FENDER WASHER)

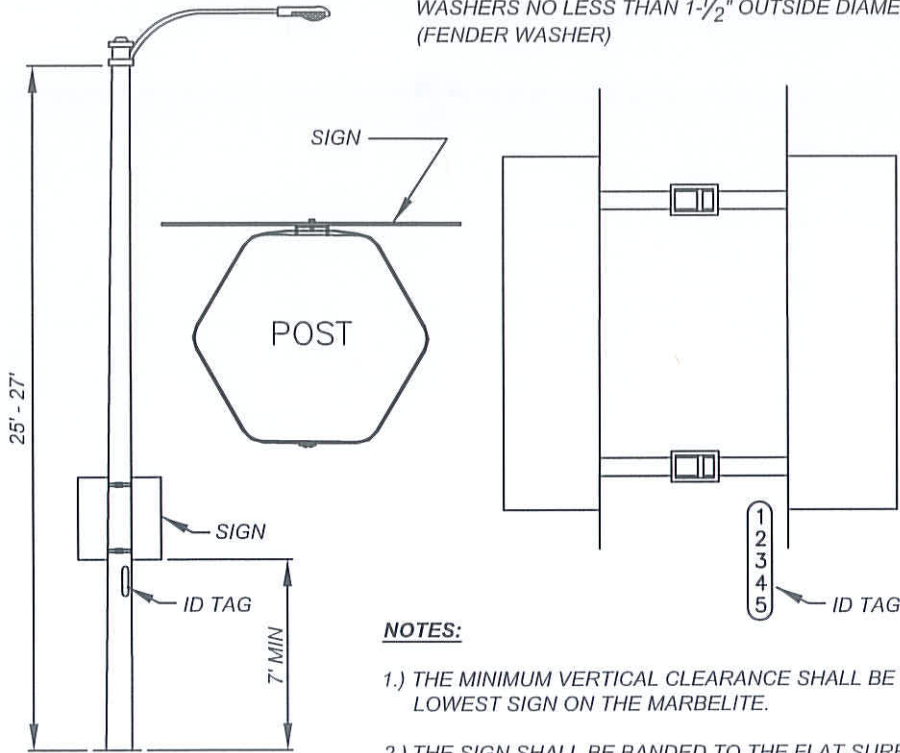

**NOTES:**

- 1.) THE MINIMUM VERTICAL CLEARANCE SHALL BE 7' TO THE BOTTOM OF THE LOWEST SIGN ON THE MARBELITE.
- 2.) THE SIGN SHALL BE BANDED TO THE FLAT SURFACE OF THE MARBELITE THAT BEST ACCOMMODATES A 90° ANGLE TO ON COMING TRAFFIC UNLESS OTHERWISE SPECIFIED.
- 3.) THE BAND SHALL BE TIGHTENED TO A POINT AT WHICH IT DOES NOT BREAK, YET PREVENTS MOVEMENT BY HAND OF THE SIGN, BAND, OR BRACKET.
- 4.) ALL SIGNS BEING BANDED TO MARBELITE SHALL HAVE NO LESS THAN 2 BANDS (UPPER AND LOWER). ANY SIGN LARGER THAN 36" SHALL HAVE NO LESS THAN 3 BANDS (UPPER, LOWER, AND MIDDLE).
- 5.) UNDER NO CIRCUMSTANCES SHALL THE BANDS COVER THE IDENTIFICATION TAG ON THE MARBELITE.
- 6.) INSTALLATION OF 2 OR MORE SIGNS ON A SINGLE POST SHALL NOT OVERLAP. SIGNS SHOULD HAVE A 1" GAP BETWEEN EACH SIGN.

NOT TO SCALE

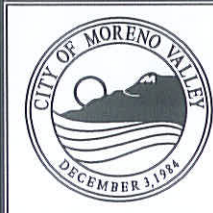

RECOMMENDED:  
 EL 1/22/14  
 DIVISION MANAGER DATE  
 APPROVED:  
 [Signature] 1/29/14  
 PUBLIC WORKS DIRECTOR / DATE  
 CITY ENGINEER

**CITY OF MORENO VALLEY**  
 PUBLIC WORKS DEPARTMENT - TRANSPORTATION ENGINEERING DIVISION

**MARBELITE  
 SIGN INSTALLATION**

STANDARD PLAN  
**MVLT-413-0**  
 SHEET 2 OF 2

RIVET LOCATIONS  
(SEE NOTE 6 ON  
STD No MVL-414B-0)

DIRECTION OF  
TRAFFIC FLOW

STREET  
SIDE  
OF  
POST

**SECTION "A-A"**

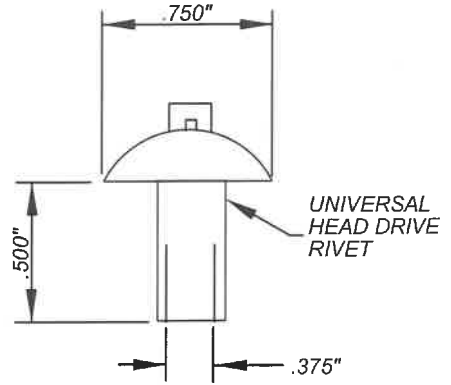

**RIVET DETAIL**

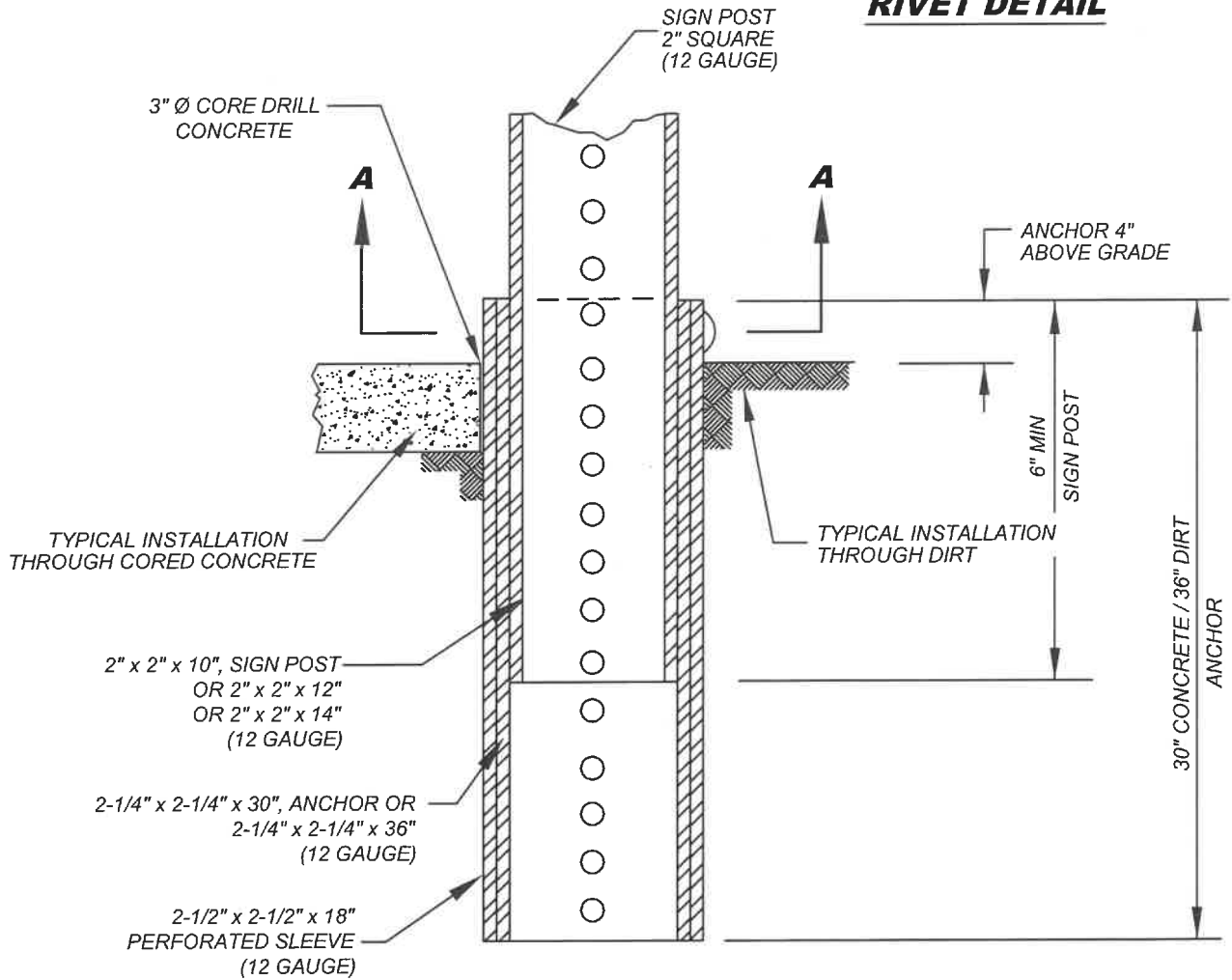

**TYPICAL SECTION**

NOT TO SCALE



RECOMMENDED:

EL

DIVISION MANAGER

5/14/19

DATE

APPROVED:

MJ. Wolfe

6/4/19

PUBLIC WORKS DIRECTOR / DATE  
CITY ENGINEER

**CITY OF MORENO VALLEY**

PUBLIC WORKS DEPARTMENT - TRANSPORTATION ENGINEERING DIVISION

**SIGN POST INSTALLATION**

STANDARD PLAN

**MVLT-414A-0**

SHEET 1 OF 3



**NOTES:**

- 1.) SQUARE PERFORATED STEEL TUBE POSTS WITH TWO-PIECE ANCHOR AND SLEEVE, "TELESPAR", SHALL BE USED FOR ALL TRAFFIC CONTROL AND INFORMATIONAL SIGNS WITHIN THE PUBLIC RIGHT-OF-WAY.
- 2.) THE NUMBER OF POSTS REQUIRED FOR SIGN INSTALLATION SHALL BE DETERMINED BY THE AREA OF THE SIGN OR COMBINATION OF SIGNS TO BE INSTALLED. A SINGLE POST SHALL BE USED WHERE BOTH THE LENGTH AND WIDTH ARE FORTY-EIGHT (48") INCHES OR LESS. DOUBLE POSTS SHALL BE USED WHERE EITHER THE LENGTH OR THE WIDTH EXCEEDS FORTY-EIGHT (48") INCHES.
- 3.) THE TWO-PIECE ANCHOR AND SLEEVE ASSEMBLY SHALL CONSIST OF A TWO AND A QUARTER INCHES SQUARE BY THIRTY (30) INCHES (2-1/4" x 30") [THROUGH SIDEWALKS], OR THIRTY-SIX (36) INCHES [THROUGH SOIL] ANCHORED WITH A TWO AND ONE-HALF INCHES SQUARE BY EIGHTEEN (18) INCHES (2-1/2" x 18") SLEEVE. ALL SLEEVES AND ANCHORS SHALL BE TWELVE (12) GAUGE.
- 4.) THE ANCHOR AND SLEEVE ASSEMBLIES SHALL BE DRIVEN SIMULTANEOUSLY UNTIL ONLY FOUR (4") INCHES REMAINS ABOVE GROUND LEVEL.
- 5.) ALL DIRT SHALL BE REMOVED FROM THE INSIDE TOP SIX (6") INCHES MINIMUM OF THE ANCHOR ASSEMBLY TO ALLOW FOR INSTALLATION OF THE SIGN POST.
- 6.) INSTALL THE TWO (2") INCHES SQUARE SIGN POST MINIMUM SIX (6") INCHES INTO THE ANCHOR ASSEMBLY AND SECURE IN PLACE WITH TWO (2) 3/8-INCH DRIVE RIVETS AS SHOWN. THE RIVETS SHALL BE INSTALLED ON THE SIDE FACING TRAFFIC FLOW, AND THE SIDE OF APPROACHING TRAFFIC AS SHOWN IN ORDER TO ACHIEVE THE MAXIMUM BREAK-AWAY EFFECT.
- 7.) INSTALLATION ACCORDING TO THESE REQUIREMENTS IS ESSENTIAL TO MAINTAIN THE BREAK-AWAY CHARACTERISTICS OF THE POST SYSTEM. UNDER NO CIRCUMSTANCES SHALL THE ANCHOR ASSEMBLY BE SECURED IN CONCRETE FOOTINGS.
- 8.) THE BOTTOM OF THE LOWEST SIGN ON THE POST SHALL BE A MINIMUM OF SEVEN (7') FEET ABOVE THE FINISHED SURFACE.
- 9.) SEE CITY STANDARD PLAN NO. MVLT-414C FOR PLACEMENT OF SIGN POST.
- 10.) ALL ANCHOR ASSEMBLIES SHALL BE CORE DRILLED WITH THREE (3") INCHES DIAMETER THROUGH CONCRETE AND ASPHALT.
- 11.) ALL SIGNS ATTACHED TO PERFORATED POSTS SHALL HAVE ZINC COATED OR STAINLESS STEEL WASHERS BEHIND THE RIVET THAT ARE LARGER THAN THE HEAD OF THE RIVET (FENDER WASHERS PREFERRED).
- 12.) ALL REGULATORY, WARNING, AND GUIDE SIGNS INSTALLED SHALL BE GREATER THAN 0.080 INCHES IN THICKNESS WITH SHEETING.
- 13.) ALL SIGNS THIRTY-SIX (36") INCHES OR LARGER SHALL BE INSTALLED WITH BACK BRACES SPECIFICALLY DESIGNED FOR TWO (2") INCHES SQUARE PERFORATED POSTS (2-INCH RISE).
- 14.) ALL SIGNS FIFTY (50") INCHES OR GREATER SHALL BE INSTALLED WITH ONE AND ONE-HALF INCHES BY ONE AND ONE-HALF INCHES (1-1/2" x 1-1/2") ALUMINUM U-CHANNEL BACK BRACES THAT ARE SPECIFICALLY DESIGNED FOR TWO (2") INCHES SQUARE PERFORATED POSTS.

NOT TO SCALE

	RECOMMENDED: <i>Wei Sun</i> 1/30/23 PRINCIPAL ENGINEER      DATE	<h2 style="margin: 0;">CITY OF MORENO VALLEY</h2> <p style="margin: 0;">PUBLIC WORKS DEPARTMENT - TRANSPORTATION ENGINEERING DIVISION</p>
	APPROVED: <i>William Walker</i> 1/31/23 PUBLIC WORKS DIRECTOR / DATE CITY ENGINEER	<h3 style="margin: 0;">SIGN POST INSTALLATION NOTES</h3>

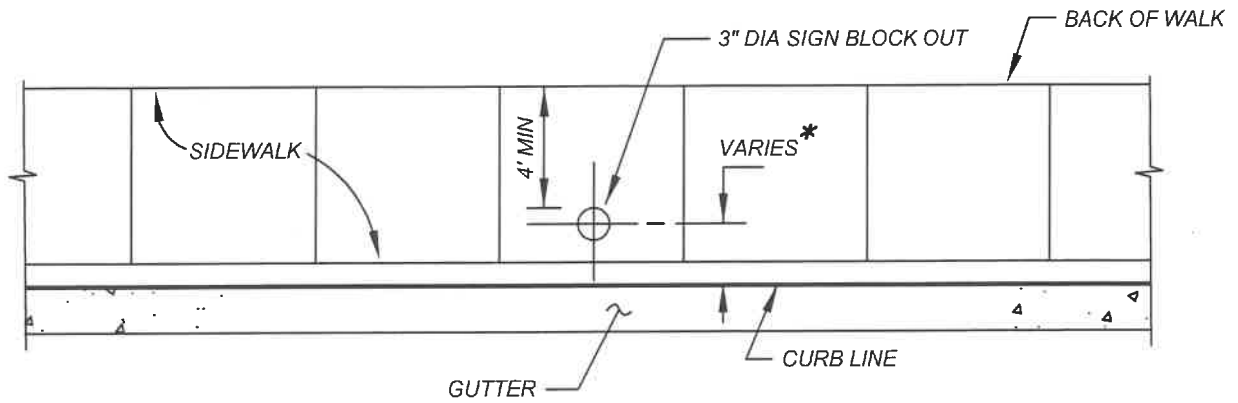

**SIDEWALK LOCATION**

\*DISTANCE DETERMINED BY WIDTH OF SIGN.

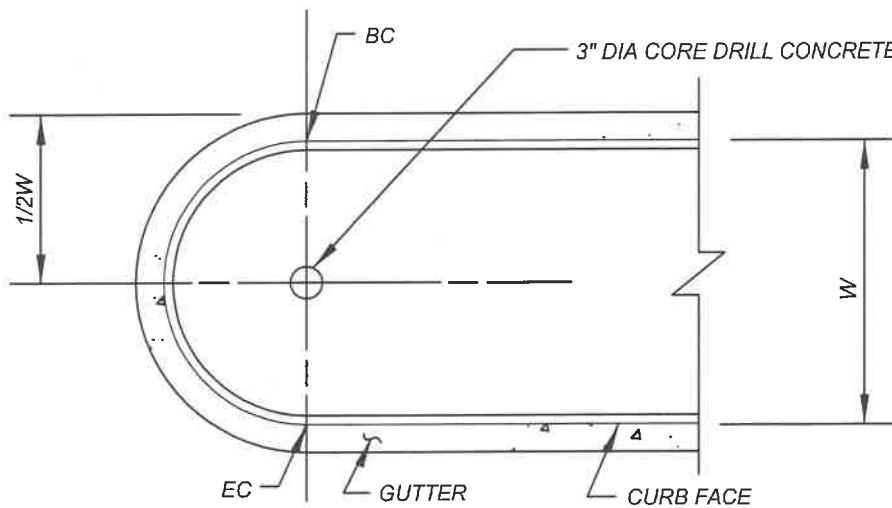

**MEDIAN LOCATION**

**NOTES:**

- 1.) SIGN POST 3" CORE DRILL SHALL BE USED FOR ANY SIGN IN CONCRETE.
- 2.) SIGNS LARGER THAN 48 INCHES OR LOCATIONS WHERE SIDEWALKS ARE LESS THAN 5 FEET WIDE, SIGN POST MUST BE INSTALLED BEHIND THE SIDEWALK.
- 3.) SEE STANDARD PLAN NO. MVS1-115D-0 FOR SIDEWALK PLACEMENT AROUND OBSTRUCTIONS.

NOT TO SCALE

	RECOMMENDED: <i>EL</i> DIVISION MANAGER	<i>5/14/19</i> DATE	<b>CITY OF MORENO VALLEY</b> PUBLIC WORKS DEPARTMENT - TRANSPORTATION ENGINEERING DIVISION	STANDARD PLAN <b>MVLT-414C-0</b>
	APPROVED: <i>MAL. WOLFE</i> PUBLIC WORKS DIRECTOR/ CITY ENGINEER	<i>6/4/19</i> DATE		<b>SIGN POST BLOCK OUT</b>

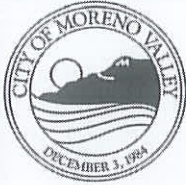

# City of Moreno Valley Road Work

Project Description  
and Limits

Start - Completion Date

City Council:  
<Name>, Mayor  
<Name>, Mayor Pro Tem  
<Name Only>  
<Name Only>  
<Name Only>

Moreno Valley Public Works  
951.413.3130  
www.moreno-valley.ca.us

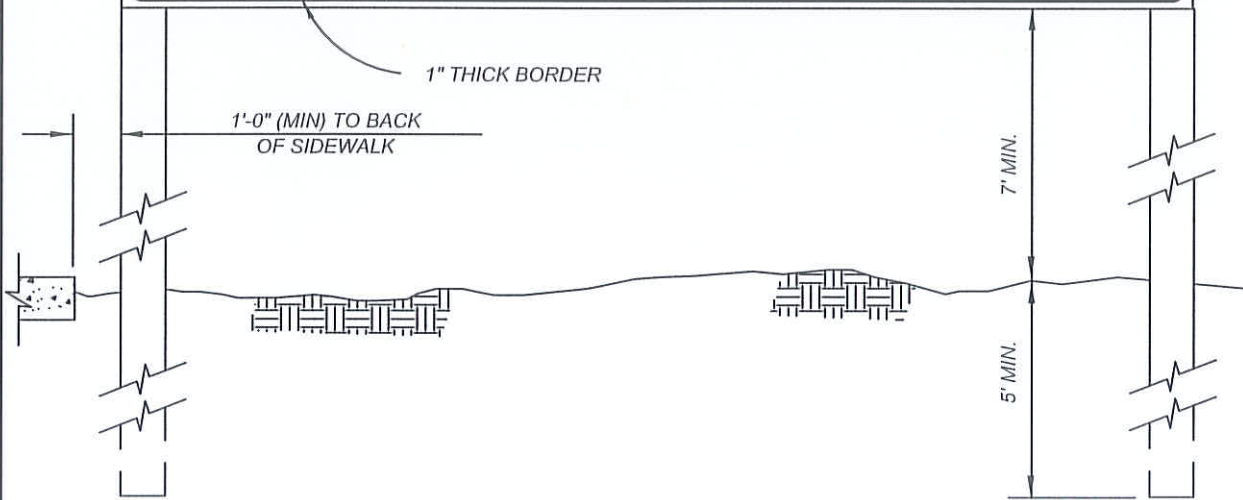

**NOTES:**

- 1.) SIGNS SHALL BE SECURELY MOUNTED ON (2) 4" x 4" POSTS.
- 2.) SIGNS SHALL BE MADE WITH NEW MATERIAL AND IN ONE PANEL. OUTSIDE DIMENSIONS SHALL BE 4' x 8'.
- 3.) LETTERS AND BORDER SHALL BE BLACK ON WHITE BACKGROUND.
- 4.) ENGINEER TO PROVIDE PROJECT DESCRIPTION, LIMITS, NAMES OF CURRENT CITY COUNCIL MEMBERS AND GRAPHICS.
- 5.) CITY CAN PROVIDE "PROOF" LAYOUT IN DIGITAL FORMAT.
- 6.) CONTRACTOR / DEVELOPER TO PROVIDE FINAL "PROOF" ON 11" x 17" PAPER FROM VENDOR FOR CITY APPROVAL PRIOR TO MANUFACTURING THE SIGN.
- 7.) CONTRACTOR / DEVELOPER TO PROVIDE PHOTOGRAPH OF ACTUAL 4' x 8' SIGN FOR CITY APPROVAL PRIOR TO INSTALLATION.

NOT TO SCALE



RECOMMENDED:  
 1/21/14  
 DIVISION MANAGER / DATE  
 APPROVED:  
 1/29/14  
 PUBLIC WORKS DIRECTOR / DATE  
 CITY ENGINEER

CITY OF MORENO VALLEY  
PUBLIC WORKS DEPARTMENT - CAPITAL PROJECTS DIVISION

**PROJECT SIGN  
(ROAD WORK)**

STANDARD PLAN  
**MVLT-415A-0**

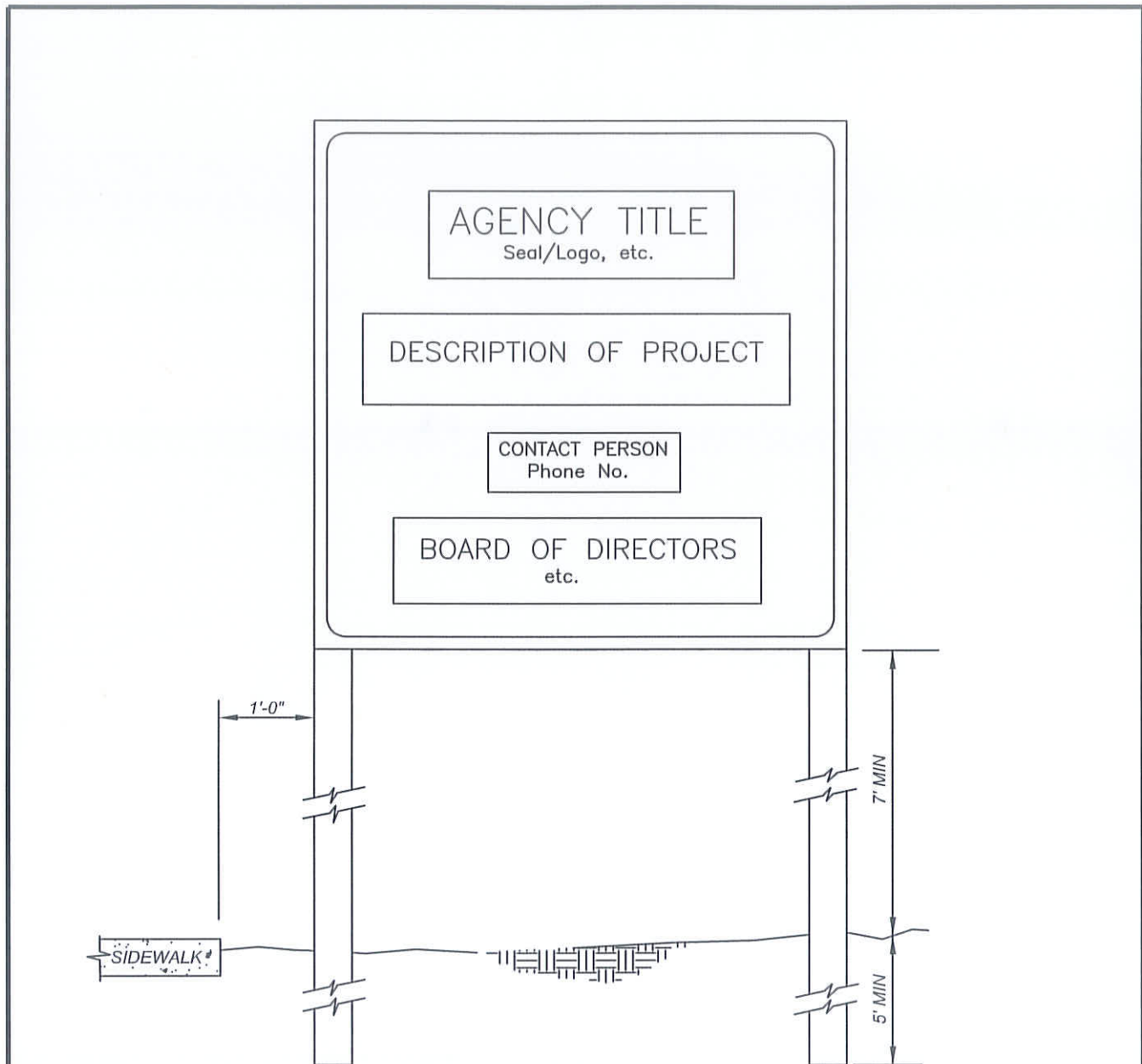

SHEET 1 OF 3



**NOTES:**

- 1.) SIGNS SHALL BE SECURELY MOUNTED ON (2) 4" x 4" POSTS.
- 2.) OUTSIDE DIMENSIONS SHALL BE 4' x 8'.
- 3.) LETTERS AND BORDER SHALL BE BLACK ON WHITE BACKGROUND.
- 4.) SIGN TO BE INSTALLED PRIOR TO FIRST DAY OF WORK.
- 5.) MINIMUM 2 SIGNS TO BE INSTALLED.

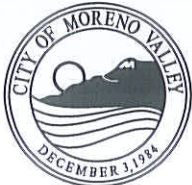
NOT TO SCALE

	RECOMMENDED:  DIVISION MANAGER / DATE 1/21/14	<h2 style="margin: 0;">CITY OF MORENO VALLEY</h2> <p style="margin: 0;">PUBLIC WORKS DEPARTMENT - CAPITAL PROJECTS DIVISION</p>	
	APPROVED:  PUBLIC WORKS DIRECTOR / DATE 1/29/14 CITY ENGINEER	<h3 style="margin: 0;">PROJECT SIGN (OTHER AGENCIES)</h3>	STANDARD PLAN <h3 style="margin: 0;">MVL-415B-0</h3>
		SHEET 2 OF 3	



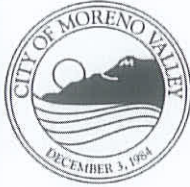

City of Moreno Valley

# Project Completion

## Roadway Improvements

### Thank you for your cooperation

City Council:  
<Name>, Mayor  
<Name>, Mayor Pro Tem  
<Name Only>  
<Name Only>  
<Name Only>

Moreno Valley Public Works  
**951.413.3130**  
www.moreno-valley.ca.us

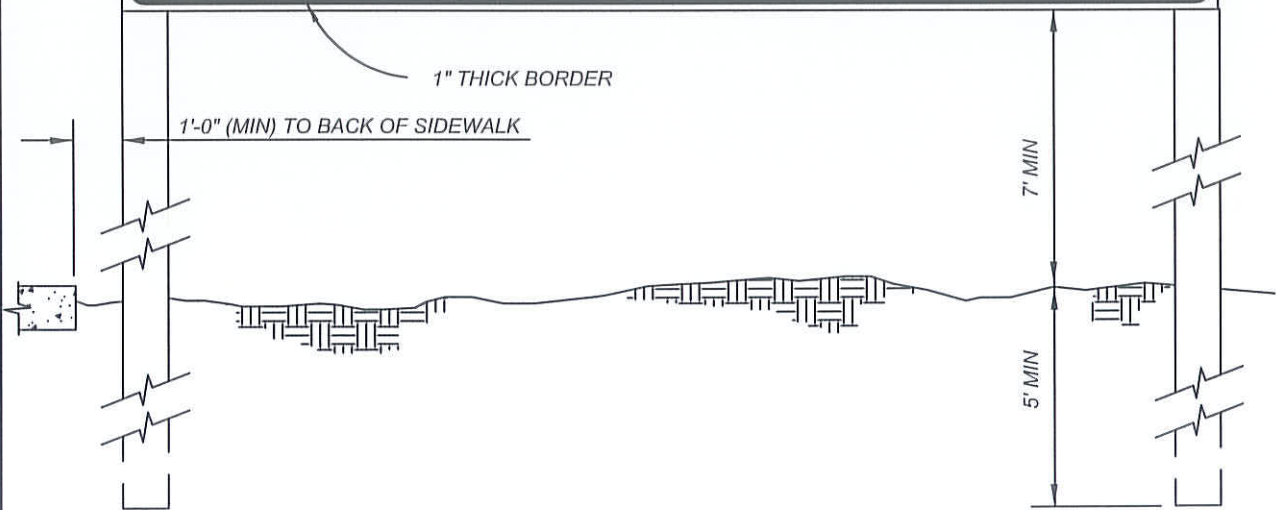

#### NOTES:

- 1.) SIGNS SHALL BE SECURELY MOUNTED ON (2) 4" x 4" POSTS.
- 2.) SIGNS SHALL BE MADE WITH NEW MATERIAL AND IN ONE PANEL. OUTSIDE DIMENSIONS SHALL BE 4' x 8'.
- 3.) LETTERS AND BORDER SHALL BE BLACK ON WHITE BACKGROUND.
- 4.) ENGINEER TO PROVIDE PROJECT DESCRIPTION, LIMITS, NAMES OF CURRENT CITY COUNCIL MEMBERS AND GRAPHICS.
- 5.) CITY CAN PROVIDE "PROOF" LAYOUT IN DIGITAL FORMAT.
- 6.) CONTRACTOR / DEVELOPER TO PROVIDE FINAL "PROOF" ON 11" x 17" PAPER FROM VENDOR FOR CITY APPROVAL PRIOR TO MANUFACTURING THE SIGN.
- 7.) CONTRACTOR / DEVELOPER TO PROVIDE PHOTOGRAPH OF ACTUAL 4' x 8' SIGN FOR CITY APPROVAL PRIOR TO INSTALLATION.

NOT TO SCALE



RECOMMENDED:

*[Signature]* / 1/21/14  
DIVISION MANAGER / DATE

APPROVED:  
*[Signature]* / 1/29/14  
PUBLIC WORKS DIRECTOR / DATE  
CITY ENGINEER

**CITY OF MORENO VALLEY**  
PUBLIC WORKS DEPARTMENT - CAPITAL PROJECTS DIVISION

**PROJECT SIGN  
(PROJECT COMPLETION)**

STANDARD PLAN  
**MVLT-415C-0**  
SHEET 3 OF 3

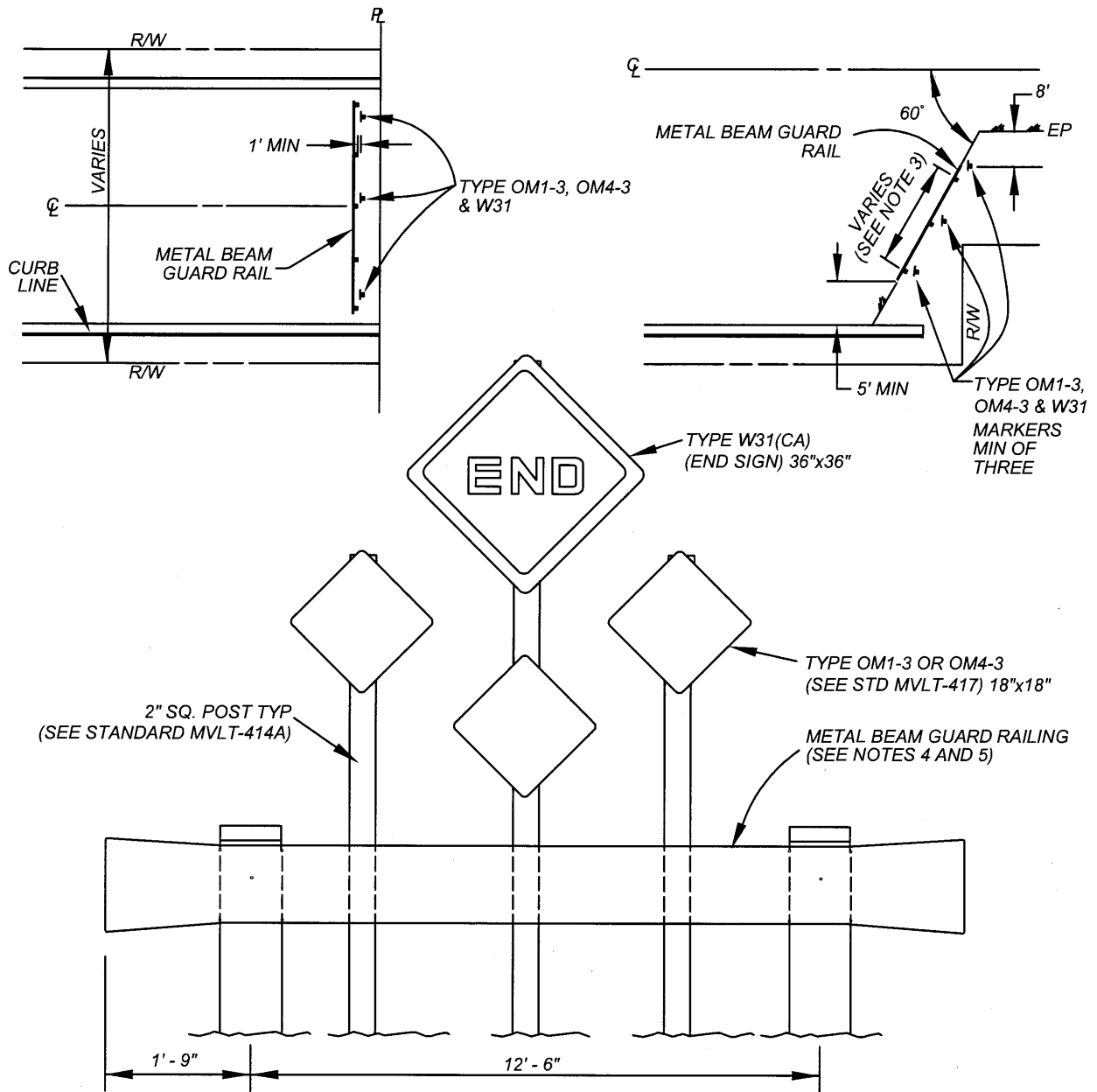

**NOTES:**

- 1.) THREE TYPE OM1-3 OR OM4-3 AND ONE W31 (END SIGN) SHALL BE PLACED AT THE END OF EACH ROADWAY AS SHOWN ON THIS STANDARD DRAWING, AND ONLY AT THE DIRECTION OF THE CITY ENGINEER.
- 2.) TYPE OM1-3 OR OM4-3 SIGNS OR TYPE W31 (END SIGNS) SHALL BE PLACED AS SHOWN WITH REFLECTIVE FACE IN DIRECT LINE OF SIGHT FOR APPROACHING MOTORIST.
- 3.) LENGTH OF METAL BEAM GUARD RAILING SHALL BE IN MULTIPLES OF 12'-6", PLUS 1'-9" FOR EACH END PIECE.
- 4.) SEE STANDARD DRAWING NUMBER MVLT-416B FOR METAL BEAM GUARD RAILING DETAILS.
- 5.) SHALL BE USED ONLY WITH THE APPROVAL BY CITY TRAFFIC ENGINEER.

NOT TO SCALE

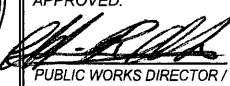
	RECOMMENDED: <b>EL</b> 12/22/16 <small>DIVISION MANAGER      DATE</small>	<h2 style="margin: 0;">CITY OF MORENO VALLEY</h2> <p style="margin: 0;">PUBLIC WORKS DEPARTMENT - TRANSPORTATION ENGINEERING DIVISION</p>	STANDARD PLAN <b>MVLT-416A-0</b>
	APPROVED:  1/20/17 <small>PUBLIC WORKS DIRECTOR / DATE</small> <small>CITY ENGINEER</small>	<h3 style="margin: 0;">END OF ROAD TREATMENT</h3>	SHEET 1 OF 2

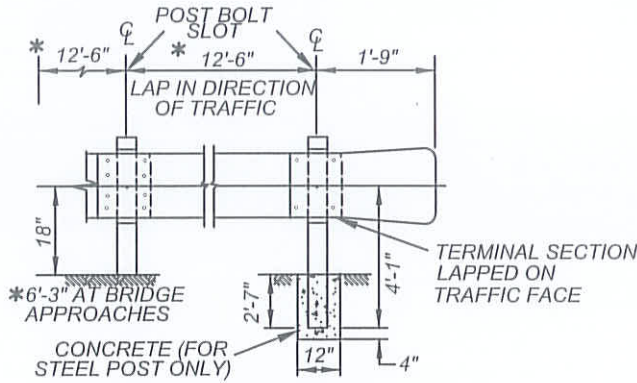

**INSTALLATION**

NOTE: GUARD RAILING FLARES AT BRIDGE APPROACHES SHALL HAVE A MINIMUM RADIUS OF 150'.

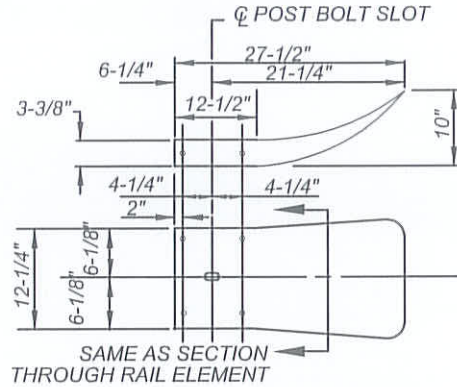

**TERMINAL SECTION**

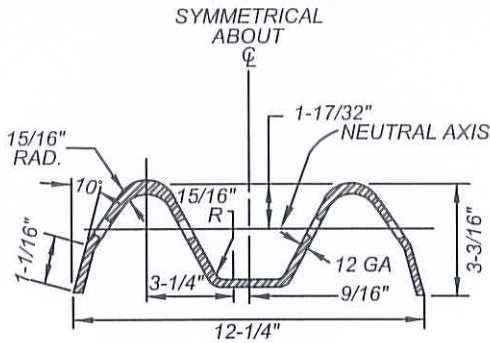

**SECTION THROUGH RAIL ELEMENT**

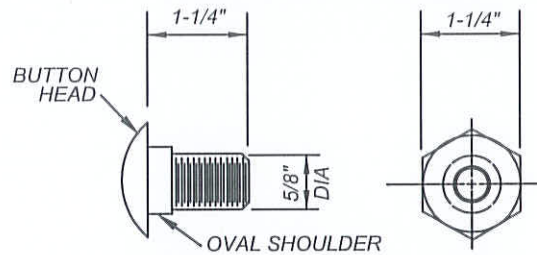

**SPLICE BOLT AND NUT**

POST BOLT: SIMILAR EXCEPT LENGTH

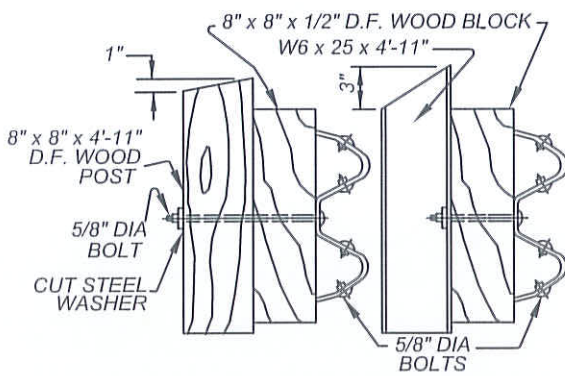

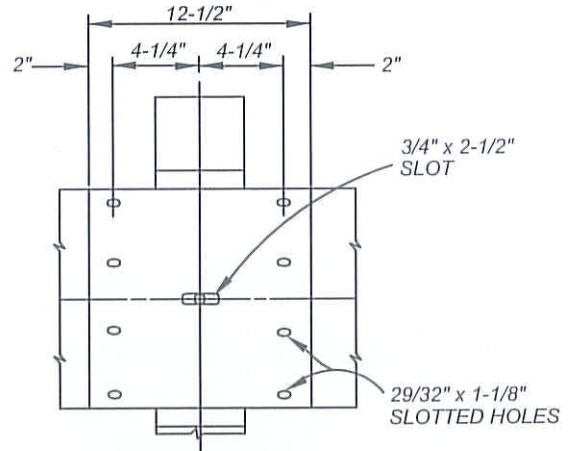

**ARRANGEMENT OF POSTS**

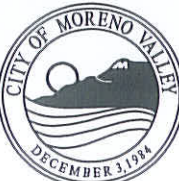

**RAIL SPLICE**

NOT TO SCALE

	RECOMMENDED: <i>EL</i> DIVISION MANAGER	<i>1/22/14</i> DATE	<b>CITY OF MORENO VALLEY</b> PUBLIC WORKS DEPARTMENT - TRANSPORTATION ENGINEERING DIVISION	<b>END OF ROAD TREATMENT DETAILS</b>	STANDARD PLAN <b>MVLT-416B-0</b>
	APPROVED:  PUBLIC WORKS DIRECTOR / CITY ENGINEER	<i>1/29/14</i> DATE			SHEET 2 OF 2

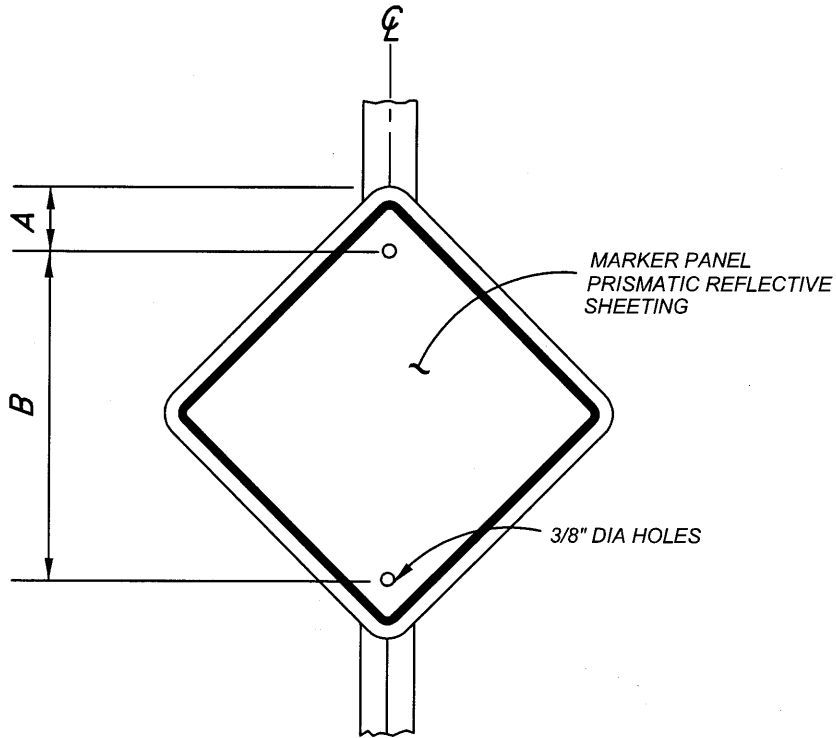

**TYPE OM1-3 & OM4-3**

TYPE	SIZE	BORDER WIDTH	MARGIN WIDTH	A	B	C	CORNER RADIUS
OM1-3 & OM4-3	18"x18"	3/8"	3/8"	3"	18"	---	1-1/2"

**NOTES:**

- 1.) "OM1-3"-YELLOW DG3 BACKGROUND WITH BLACK BORDER.
- 2.) "OM4-3"-RED PRISMATIC BACKGROUND WITH BLACK BORDER.
- 3.) "OM1-3"-ORANGE PRISMATIC BACKGROUND WITH BLACK BORDER.

NOT TO SCALE

	RECOMMENDED: <b>EL</b> 12/22/16 <small>DIVISION MANAGER      DATE</small>	<b>CITY OF MORENO VALLEY</b> PUBLIC WORKS DEPARTMENT - TRANSPORTATION ENGINEERING DIVISION	<small>STANDARD PLAN</small>
	APPROVED:  <small>PUBLIC WORKS DIRECTOR / DATE</small> 1/20/17		<b>OBJECT MARKERS</b>
	<small>CITY ENGINEER</small>		<small>SHEET 1 OF 1</small>



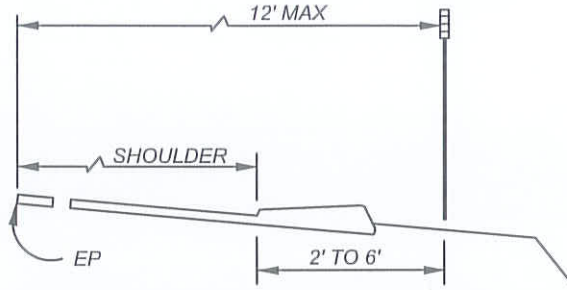

**DELINEATOR POSITIONING**

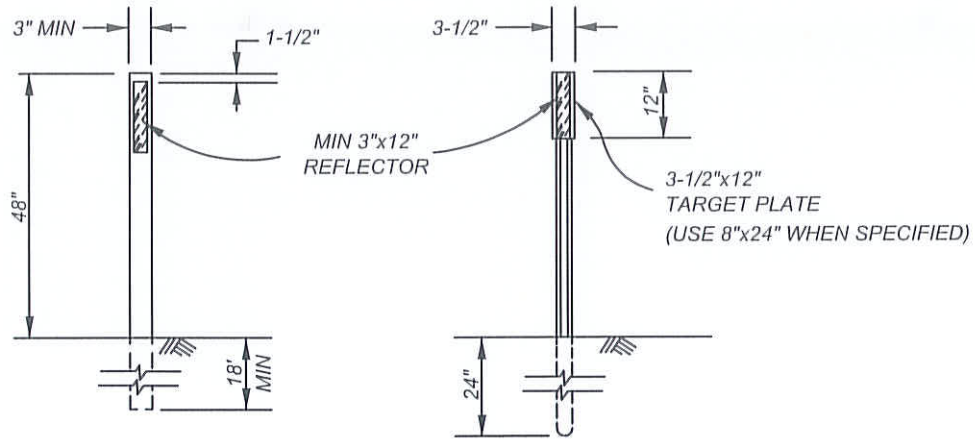

**CLASS 1 FLEXIBLE POST**

**CLASS 2 METAL POST**

**DELINEATORS**



**DELINEATOR REFLECTORIZATION**

TYPE	REFLECTOR COLOR	
	FRONT	BACK
E	WHITE	WHITE (SEE NOTE 1)
F	WHITE	NONE
G	YELLOW	NONE
I	YELLOW	YELLOW (SEE NOTE 1)

**NOTES:**

- 1.) THE REFLECTOR USED ON BACK OF DELINEATOR SHALL BE ONE 3" SQUARE REFLECTIVE SHEETING ON CLASS 1 DELINEATOR AND ONE STANDARD REFLEX REFLECTOR ON CLASS 2 DELINEATOR.
- 2.) THE TYPE OF REFLECTORIZATION AND THE CLASS OF DELINEATOR TO BE INSTALLED WILL BE DESIGNATED ON THE PLANS AS E-1, F-2, ETC.

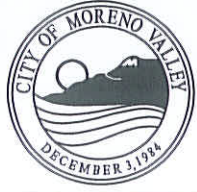
NOT TO SCALE

	RECOMMENDED: EL 1/22/14 DIVISION MANAGER DATE	<b>CITY OF MORENO VALLEY</b> PUBLIC WORKS DEPARTMENT - TRANSPORTATION ENGINEERING DIVISION	
	APPROVED:  PUBLIC WORKS DIRECTOR / DATE CITY ENGINEER	<b>DELINEATORS</b>	

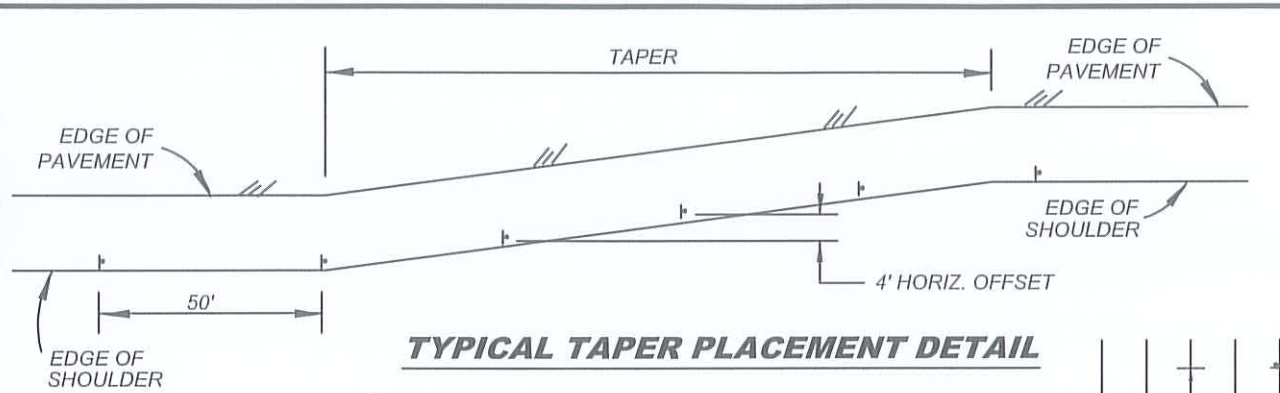

**TYPICAL TAPER PLACEMENT DETAIL**

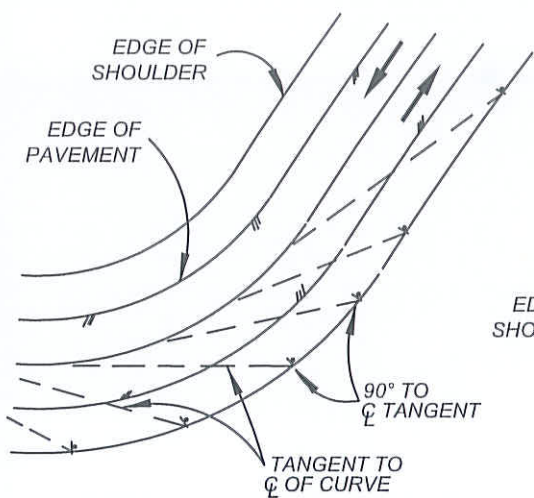

**CURVE PLACEMENT DETAIL**

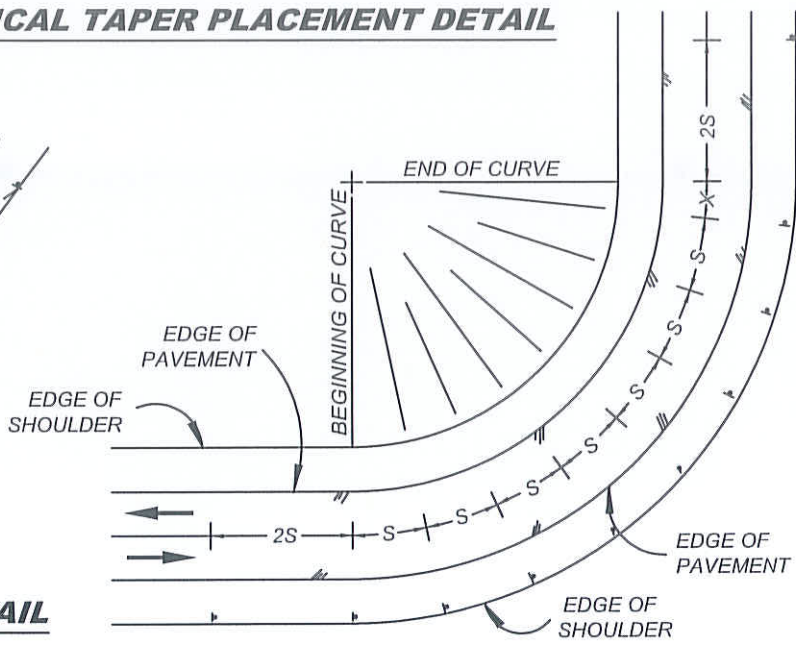

**SPACING DETAIL**

**TABLE 1**

R in feet	S in feet
50'	20'
75'	20'
100'	25'
150'	30'
200'	35'
300'	40'
400'	40'
500'	40'
600'	40'
700'	75'
800'	80'
900'	85'
1000'	90'
1200'	100'
1400'	110'
1600'	115'
1800'	125'
2000'	130'

**NOTES:**

- 1.) MAXIMUM SPACING BETWEEN DELINEATORS = 300', MINIMUM = 20'.
- 2.) DELINEATOR SPACING ON CURVES LESS THAN 2000' RADIUS SHALL CONFORM TO THE SPACING INDICATED IN TABLE 1.
- 3.) PRORATE DISTANCE "X" AMONG ALL SPACING WITHIN CURVE SO LAST DELINEATOR FALLS AT THE END OF CURVE.

**LEGEND:**

- S = DELINEATOR SPACING IN FEET.  $S = 3\sqrt{R-50}$ .
- R = CENTERLINE CURVE RADIUS IN FEET.
- ▬ = DELINEATOR TYPE F CLASS I
- X = DISTANCE REMAINING WITHIN CURVE FROM LAST CALCULATED DELINEATOR TO END OF CURVE.

NOT TO SCALE

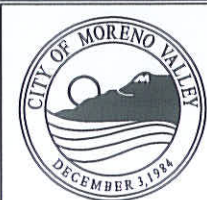

RECOMMENDED:  
 EL  
 DIVISION MANAGER  
 APPROVED:  
 PUBLIC WORKS DIRECTOR / CITY ENGINEER  
 DATE: 1/22/14  
 DATE: 1/29/14

**CITY OF MORENO VALLEY**  
 PUBLIC WORKS DEPARTMENT - TRANSPORTATION ENGINEERING DIVISION

**DELINEATOR PLACEMENT**

STANDARD PLAN  
**MVLT-418B-0**  
 SHEET 2 OF 2

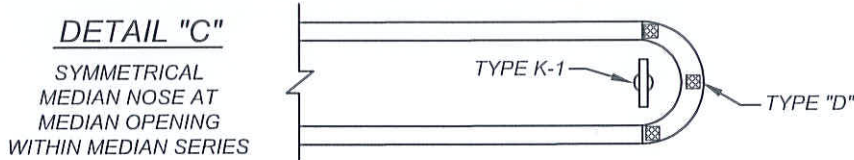
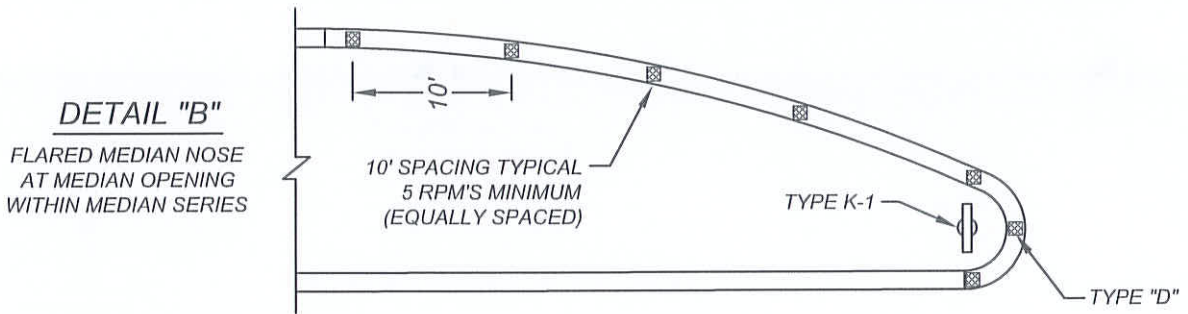
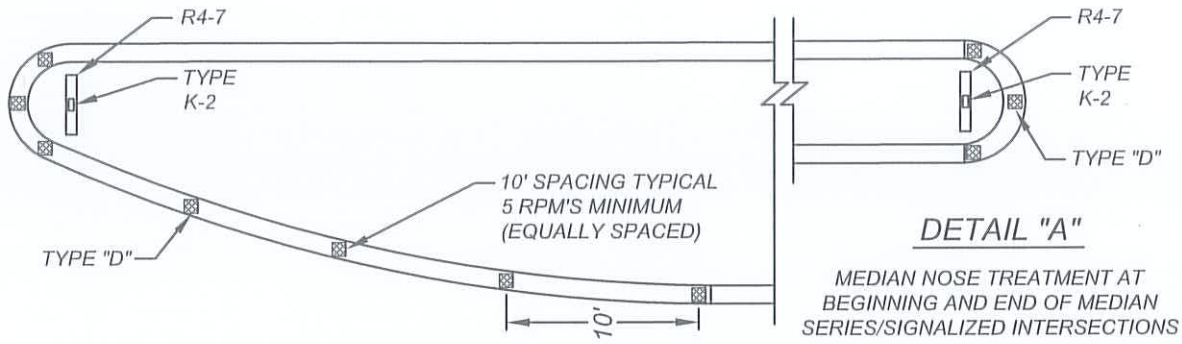

**MARKER DETAILS**

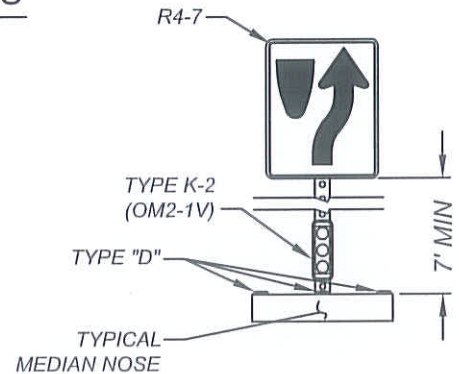
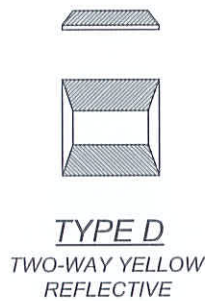
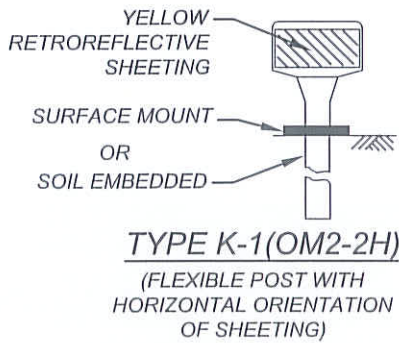

**LEGENDS**

- R4-7 MEDIAN SIGN AND TYPE K-2 (OM2-1V) OBJECT MARKER
- TYPE K-1 (OM2-2H) OBJECT MARKER
- TYPE "D" RAISED PAVEMENT MARKER

NOT TO SCALE

	RECOMMENDED:  1/22/14 DIVISION MANAGER DATE	<b>CITY OF MORENO VALLEY</b> PUBLIC WORKS DEPARTMENT - TRANSPORTATION ENGINEERING DIVISION	STANDARD PLAN <b>MVLT-419-0</b>
	APPROVED:  1/29/14 PUBLIC WORKS DIRECTOR / DATE CITY ENGINEER	<b>MEDIAN NOSE TREATMENT</b>	



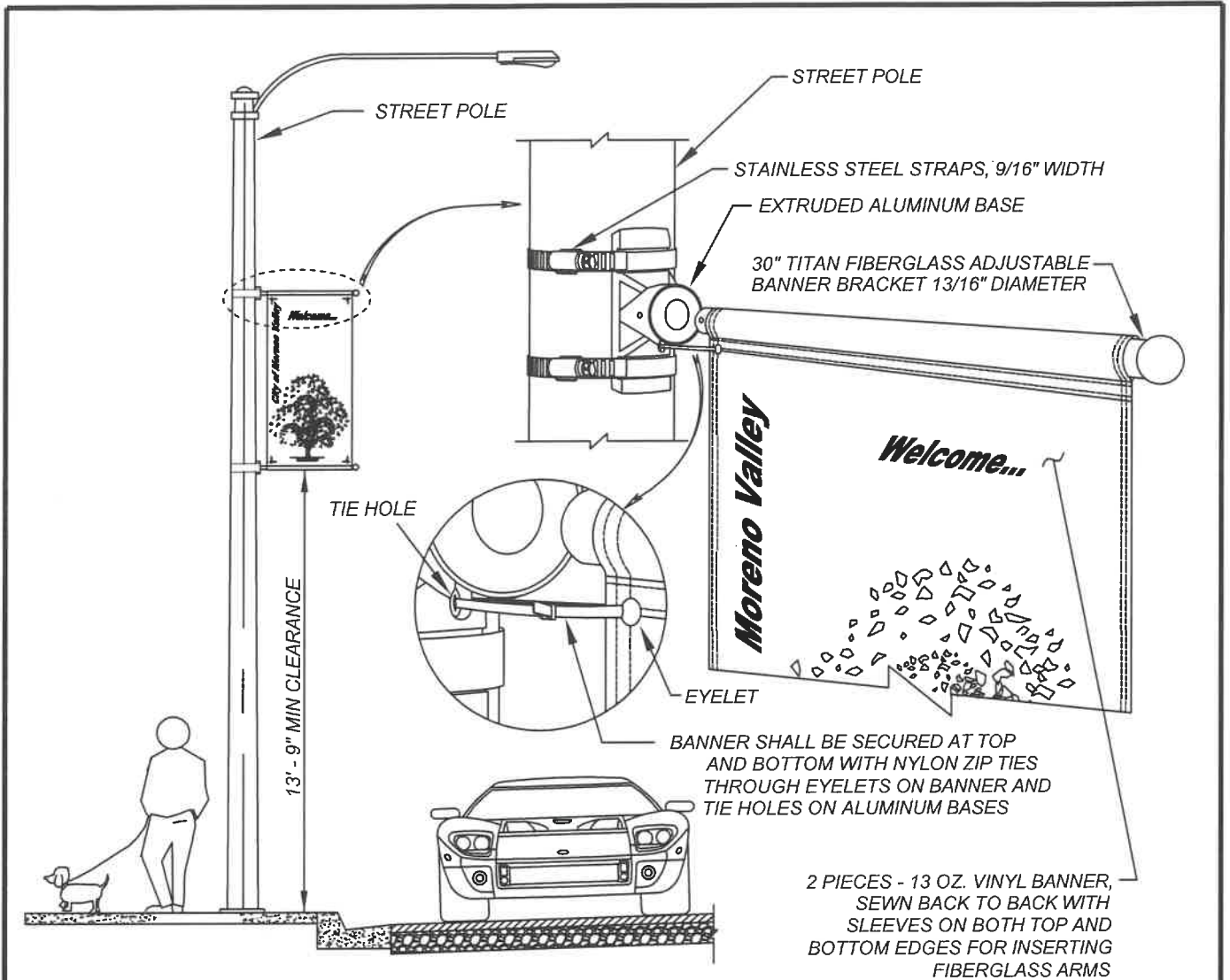

**NOTES:**

- 1.) THE BANNER SIZE SHALL BE 30" x 84". TOTAL SURFACE AREA OF BANNER AND ANY TRAFFIC SIGNS ON LUMINAIRE STANDARD SHALL NOT EXCEED 18 SQUARE FEET.
- 2.) INKS USED SHALL BE 4-COLOR PROCESS, UV STABILIZING INKS, AND HAVE A LIFE EXPECTANCY OF FIVE (5) YEARS.
- 3.) PRINT SHALL BE ON BOTH SIDES OF BANNER.
- 4.) BANNER ARTWORK SHALL BE REVIEWED AND APPROVED BY CITY MANAGER'S OFFICE OR CITY COUNCIL PRIOR TO PRINTING OF BANNER.
- 5.) FIBERGLASS BANNER ARM SHALL BE FLEXIBLE TO WITHSTAND UP TO 90 MPH WINDS (ARM WILL FLEX IN HIGH WINDS THEN RETURN TO ITS NORMAL POSITION ON THE POLE).
- 6.) ALUMINUM BASE OF BANNER ARM SHALL BE SECURED TO STREET POLE BY MEANS OF STAINLESS STEEL STRAPS ONLY. HOLES SHALL NOT BE PUNCHED, DRILLED, OR BURNED IN ANY POLES.
- 7.) DEPENDING ON POLE OWNERSHIP, BANNER INSTALLATION WILL REQUIRE SEPARATE APPROVALS FROM OWNER.

NOT TO SCALE

	RECOMMENDED: <i>EL</i> DIVISION MANAGER	<i>5/14/09</i> DATE	<b>CITY OF MORENO VALLEY</b> PUBLIC WORKS DEPARTMENT - TRANSPORTATION ENGINEERING DIVISION	STANDARD PLAN <b>MVLT-420-0</b>
	APPROVED: <i>M.L. Wolfe</i> PUBLIC WORKS DIRECTOR / CITY ENGINEER	<i>6/4/09</i> DATE		



COLLECTOR / ARTERIAL

TRANSITION SPEED x SHIFT  
PER SIGNING AND STRIPING PLAN

80' OPENING (WHERE APPLICABLE)

TRAFFIC SIGN

CALTRANS METRIC STENCILING  
LEGENDS 50' SPACING

DET 9 OR DET 12 CONTINUOUS  
AT T-INTERSECTION

DET 32

80' OPENING  
PREFERRED

TYPICAL LEAD-IN STRIPE  
RPMS 25FT SPACING

SIG POLE  
PPB

CITY STD MVLT-432-1  
WHITE OR YELLOW (SCHOOL AREA)  
WIDTH DETERMINED BY CITY ENGINEER

DET 6

DET 22

ADVANCE LIMIT LINE

PAINT SPEED LEGEND

TRANSITION SPEED x SHIFT  
PER SIGNING AND STRIPING PLAN

TYPE VI ARROWS

DET 27B

$\Delta/2$

$\Delta/2$

STRIPING TERMINATES AT  
UNMARKED CROSSWALK SETBACK,  
TYPICALLY 6FT FROM DELTA OR  
DETERMINED BY CITY ENGINEER.

DET 9 OR 12

TYPICAL LEAD-OUT STRIPE  
RPM 25FT SPACING

MVLT-433-0 WHITE OR YELLOW (SCHOOL AREA)  
CONTINENTAL CROSSWALK WIDTH  
DETERMINED BY CITY ENGINEER

STOP BAR/STOP LEGEND  
PLACEMENT MVLT-431-1

DET 22

LOCAL ROAD

SIG P W/ PPB

DET 40 (DUAL-LEFT)

TYPE IV(L) ARROW (TYPICAL)

DET 9 OR 12

DET 27B

**NOTES:**

1.) TYPICAL STRIPING DETAIL PER CALTRANS DETAILS OR CITY STANDARDS.

NOT TO SCALE

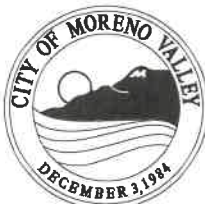

RECOMMENDED:

*Wesley* 10/3/24  
DIVISION MANAGER DATE

APPROVED:

*Michael P. ...* 10/9/24  
PUBLIC WORKS DIRECTOR/ DATE  
CITY ENGINEER

# CITY OF MORENO VALLEY

PUBLIC WORKS DEPARTMENT - TRANSPORTATION ENGINEERING DIVISION

## STREET STRIPING & PAVEMENT LEGEND STANDARDS & SPECIFICATIONS

STANDARD PLAN

**MVLT-430A-1**

SHEET 1 OF 3

**TRAFFIC STRIPES AND PAVEMENT MARKING REQUIREMENTS:**

ALL WORK AND MATERIALS SHALL CONFORM TO THE LATEST PROVISIONS SET FORTH IN SECTION 84, "TRAFFIC STRIPES AND PAVEMENT LEGENDS" OF THE STATE OF CALIFORNIA, DEPARTMENT OF TRANSPORTATION STANDARD SPECIFICATIONS, EXCEPT AS NOTED OTHERWISE.

**MATERIALS**

PAINT FOR TRAFFIC STRIPING AND PAVEMENT LEGENDS SHALL BE WHITE, YELLOW OR BLACK AS REQUIRED, SHALL BE WATER BORNE TRAFFIC PAINT, FAST DRY CONFORMING TO CALIFORNIA STATE SPECIFICATIONS AND SHALL BE REVIEWED AND APPROVED BY THE CITY ENGINEER OR DESIGNEE PRIOR TO APPLICATION. ALL STENCILS USED TO PAINT PAVEMENT LEGENDS MUST CONFORM TO THE LATEST CALTRANS APPROVED METRIC STENCILING STANDARDS.

REFLECTIVE PAVEMENT MARKERS SHALL BE OF THE PRISMATIC REFLECTOR TYPE (3M MODEL 291-2Y YELLOW, 290-W WHITE) AS OUTLINED IN SECTION 85-1.05 OF THE CALTRANS STANDARD SPECIFICATIONS. NON-REFLECTIVE PAVEMENT MARKERS SHALL COMPLY WITH THE REQUIREMENTS OUTLINED IN SECTION 85-1.04A OF THE LATEST EDITION OF THE CALTRANS STANDARD SPECIFICATIONS.

TYPE "A" MARKERS SHALL BE PLASTIC AND SHALL NOT BE CERAMICS.

**APPLICATION**

THE CONTRACTOR SHALL LAYOUT AND CATTRACK THE ALIGNMENT OF THE PROPOSED STRIPING AT 15 FOOT INTERVALS AND "SPOT" THE PROPOSED PAVEMENT LEGENDS AS CALLED FOR ON THE STRIPING PLANS. STRIPING SHALL VARY NO MORE THAN 1/2 INCH IN 50 FEET FROM THE SPECIFIED ALIGNMENT. MINOR VARIATIONS MAY BE WAIVED BY THE CITY ENGINEER OR DESIGNEE.

THE CONTRACTOR SHALL NOT PROCEED WITH THE PAINTING OF ANY PAVEMENT LEGENDS AND/OR STRIPING UNTIL THE CATTRACKING AND SPOTTING IS CHECKED AND APPROVED BY THE CITY ENGINEER OR DESIGNEE.

ALL PAVEMENT LEGENDS SHALL BE INSTALLED USING A METRIC STENCIL.

TRAFFIC STRIPING AND PAVEMENT LEGENDS SHALL BE APPLIED IN TWO (2) COATS WITH AIRLESS EQUIPMENT. ALL TRAFFIC STRIPING SHALL BE PERFORMED WITH A ROADLINER TRUCK MOUNTED STRIPING MACHINE.

THE SECOND COAT OF PAINT SHALL NOT BE APPLIED UNTIL AT LEAST SEVEN (7) CALENDAR DAYS AFTER THE FIRST COAT. EACH COAT OF PAINT SHALL BE APPLIED AT THE WET FILM THICKNESS OF 10-12 MILS FOR WHITE AND YELLOW PAINT AND 7 MILS FOR BLACK PAINT. ALL PAINT SHALL BE APPLIED AT A RELATIVE HUMIDITY BELOW 75% AND AN AMBIENT TEMPERATURE ABOVE 55 °F, UNLESS WAIVED BY THE CITY ENGINEER OR DESIGNEE.

A CONTINUOUS TWO COAT 3-INCH WIDE BLACK STRIPE SHALL BE PAINTED BETWEEN THE TWO 6-INCH WIDE YELLOW STRIPES OF A DOUBLE TRAFFIC STRIPE. THIS SPECIFICATION APPLIES TO BOTH DOUBLE YELLOW CENTERLINE STRIPING AND CONTINUOUS TURN POCKET STRIPING DETAILS. THE BLACK STRIPE SHALL BE APPLIED CONCURRENTLY WITH THE SECOND COAT OF YELLOW STRIPES.

EXCEPT FOR BLACK PAINT, REFLECTIVE GLASS BEADS SHALL BE UNIFORMLY INCORPORATED IN ALL COATS OF PAINT CONCURRENTLY WITH THE APPLICATION OF THE PAINT. THE GLASS BEADS SHALL BE EMBEDDED IN THE COAT OF TRAFFIC PAINT BEING APPLIED TO A DEPTH OF AT LEAST ONE-HALF THEIR DIAMETERS. THE REFLECTIVE GLASS BEADS SHALL BE APPLIED TO THE FIRST COAT OF PAINT AT THE RATE OF 6 POUNDS OF BEADS PER GALLON OF PAINT AND TO THE SECOND COAT OF PAINT AT THE RATE OF 8 POUNDS OF BEADS PER GALLON OF PAINT.

ASPHALT SURFACES SHALL BE DRY, CLEAN, AND FREE OF CONTAMINANTS SUCH AS SURFACE OILS OR EXISTING ROAD MARKING MATERIALS. CONTAMINANTS SHALL BE REMOVED BY MECHANICAL MEANS. MATERIAL SHALL BE APPLIED ONLY WITH EQUIPMENT WHICH IS SPECIFICALLY DESIGNED AND CAPABLE OF PROPERLY MIXING AT THE POINT AND TIME OF APPLICATION.

ANY STRIPING OR PAVEMENT LEGENDS NOT SHOWN ON THE APPROVED PLAN, BUT DEEMED NECESSARY BY THE CITY ENGINEER OR DESIGNEE, SHALL BE INSTALLED BY THE CONTRACTOR PRIOR TO FINAL ACCEPTANCE OF THE STREET.

CONTRACTOR SHALL INSTALL BLUE MARKERS (3M TYPE DB OR EQUAL) ADJACENT TO FIRE HYDRANTS PER CITY STANDARDS MVL-440A, MVL-440B AND MVL-440C.

NEWLY PAINTED STRIPING AND PAVEMENT LEGENDS SHALL BE PROTECTED FROM DAMAGE BY PUBLIC TRAFFIC OR OTHER CAUSES UNTIL THE PAINT IS THOROUGHLY DRY. ANY EXISTING OR NEWLY PAINTED STRIPING OR PAVEMENT LEGENDS WHICH ARE DAMAGED AS A RESULT OF THE CONSTRUCTION, INCLUDING WHEEL LEGENDS BY PUBLIC TRAFFIC AND THE CONSTRUCTION EQUIPMENT, SHALL BE REPAINTED BY THE CONTRACTOR.

NOT TO SCALE



RECOMMENDED:  
*Wei Sun* 2/1/2022  
DIVISION MANAGER / DATE  
APPROVED:  
*[Signature]* 2/1/22  
PUBLIC WORKS DIRECTOR / DATE  
CITY ENGINEER

**CITY OF MORENO VALLEY**

PUBLIC WORKS DEPARTMENT - TRANSPORTATION ENGINEERING DIVISION

**STREET STRIPING & PAVEMENT  
LEGEND STANDARDS  
& SPECIFICATIONS**

STANDARD PLAN  
**MVL-430B-1**

SHEET 2 OF 3

**TRAFFIC STRIPES AND PAVEMENT MARKING REQUIREMENTS:**

**APPLICATION (CONTINUATION)**

ALL WORK SHALL CONFORM TO THE LATEST PROVISIONS SET FORTH IN SECTION 85, "PAVEMENT MARKERS" OF THE STATE OF CALIFORNIA, DEPARTMENT OF TRANSPORTATION STANDARD SPECIFICATIONS EXCEPT AS NOTED OTHERWISE IN THE CONTRACT TECHNICAL PROVISIONS.

REFLECTIVE PAVEMENT MARKERS MUST BE NEW AND INSTALLED PER THE APPROVED PLAN. INSTALLATION OF REFLECTIVE PAVEMENT MARKERS SHALL BE ACCOMPLISHED WITH THE USE OF A BITUMINOUS TYPE HOT-MELT ADHESIVE SUITABLE FOR BONDING MARKERS TO PORTLAND CEMENT, ASPHALTIC CONCRETE AND CHIP-SEALED ROAD SURFACES. THE COMPOSITION OF THE MATERIAL MUST BE SUCH THAT ITS PROPERTIES WILL NOT DETERIORATE WHEN HEATED TO AND APPLIED AT TEMPERATURES UP TO 425° F. USING EITHER AIR OR OIL JACKETED MELTERS.

REFLECTIVE PAVEMENT 3M TYPE MARKERS SHALL BE PLACED ON A LOCATION ESTABLISHED BY THE APPLICABLE CALTRANS STRIPING DETAIL NOTED ON THE APPROVED STRIPING PLAN.

EXISTING TRAFFIC STRIPING AND PAVEMENT LEGENDS THAT DO NOT CONFORM TO THE APPROVED PLAN SHALL BE REMOVED BY WET SANDBLASTING AND/OR GRINDING MACHINE APPROVED BY CITY TRAFFIC ENGINEER OR DESIGNEE. BLACKOUT PAINTING OF EXISTING NON CONFORMING TRAFFIC STRIPING OR PAVEMENT LEGENDS SHALL NOT BE ALLOWED.

EXISTING REFLECTIVE PAVEMENT MARKERS THAT DO NOT CONFORM TO THE APPROVED PLAN SHALL BE REMOVED BY THE CONTRACTOR PRIOR TO ANY CATTRACKING OR OTHER WORK RELATED TO THE TRAFFIC STRIPING.

THERMOPLASTIC SHALL BE APPLIED TO ALL PAVEMENT LEGENDS AT 80 TO 120 MILS THICK WITH THE EXCEPTION OF SPEED LEGENDS.

NOT TO SCALE

	RECOMMENDED: <b>EL</b> 12/22/16 DIVISION MANAGER      DATE	<b>CITY OF MORENO VALLEY</b> PUBLIC WORKS DEPARTMENT - TRANSPORTATION ENGINEERING DIVISION	STANDARD PLAN
	APPROVED:  1/20/17 PUBLIC WORKS DIRECTOR / DATE CITY ENGINEER		<b>STREET STRIPING &amp; PAVEMENT LEGEND STANDARDS &amp; SPECIFICATIONS</b>
			SHEET 3 OF 3

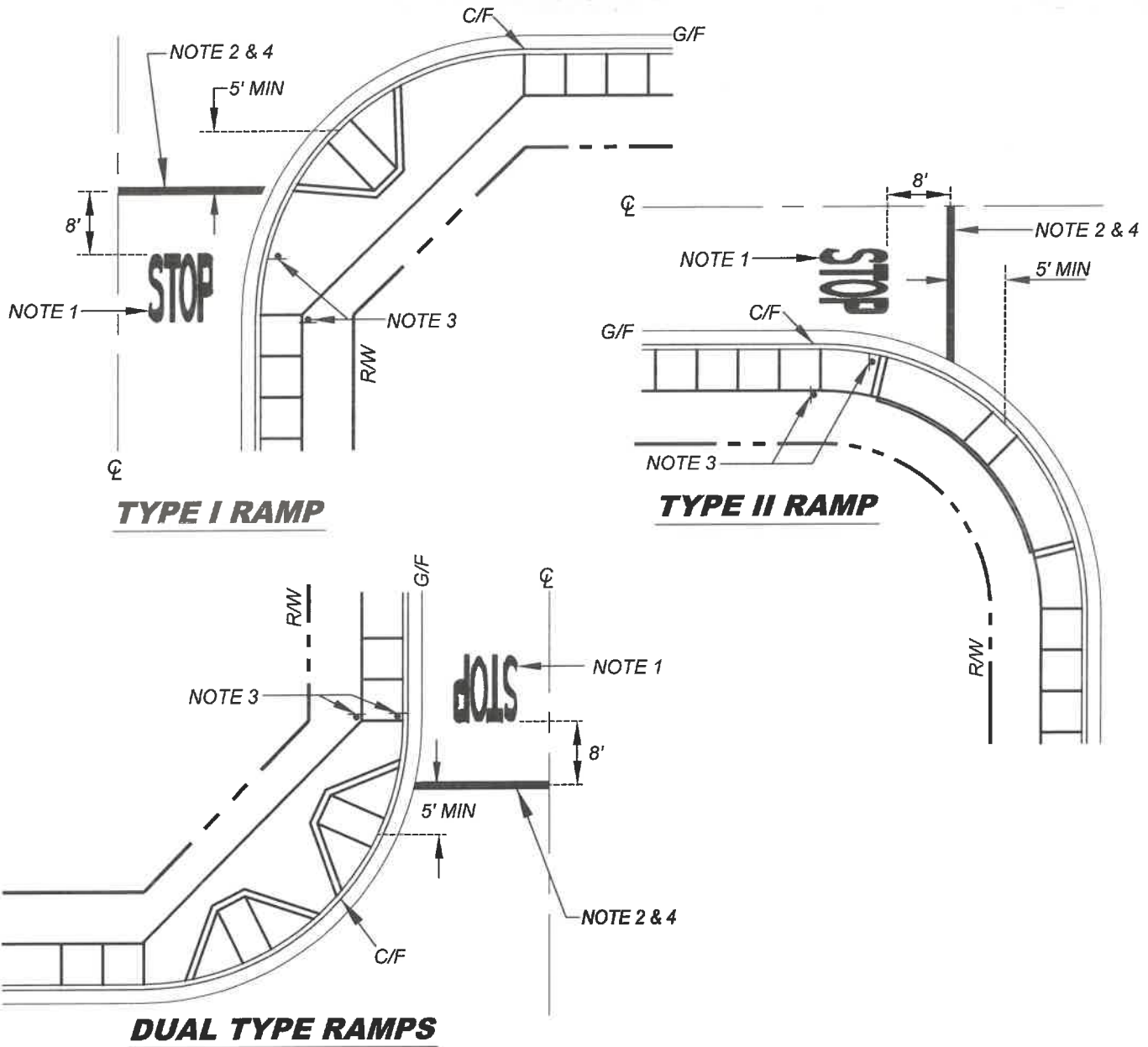

**NOTES:**

1. STOP LEGEND SHALL BE IN THERMOPLASTIC WHITE AND SHALL MEET THE LATEST CALTRANS STANDARDS A24D FOR PAVEMENT MARKINGS WORDS (METRIC STENCILING).
2. LIMIT LINE SHALL BE IN THERMOPLASTIC WHITE AND SHALL MEET THE LATEST CALTRANS STANDARD A24G. PLACEMENT SETBACK IS MEASURED FROM CENTER OF RAMP TO CENTER OF LIMIT LINE.
3. SIGN POST SHALL BE PLACED MIN. 2FT BEHIND CURBFACE (C/F) WITH STD. 36" STOP SIGN (IF SIGN IS GREATER IN SIZE, THE SIGN CANNOT HANG OVER CURB FACE & POST SETBACK WILL BE GREATER). IF SIDEWALK IS LESS THAN 6' WIDE, THE SIGN AND POST SHALL BE INSTALLED BEHIND THE SIDEWALK.
4. LIMIT LINE SHALL BE SETBACK FROM CENTER OF RAMP 5FT MINIMUM (TYPICAL FOR LOCAL ROADS & RESIDENTIAL COLLECTOR). THE SETBACK FOR COMMERCIAL COLLECTOR / ARTERIAL ROADS OR GREATER WILL DEPEND STREET WIDTH AND DETERMINED BY CITY ENGINEER.

NOT TO SCALE



RECOMMENDED:  
*Was* 10/3/24  
 DIVISION MANAGER DATE  
 APPROVED:  
*William Weber* 10/3/24  
 PUBLIC WORKS DIRECTOR / DATE  
 CITY ENGINEER

**CITY OF MORENO VALLEY**

PUBLIC WORKS DEPARTMENT - TRANSPORTATION ENGINEERING DIVISION

**STOP & LIMIT LINE  
 PAVEMENT MARKING PLACEMENT**

STANDARD PLAN  
**MVLT-431-1**

SHEET 1 OF 1



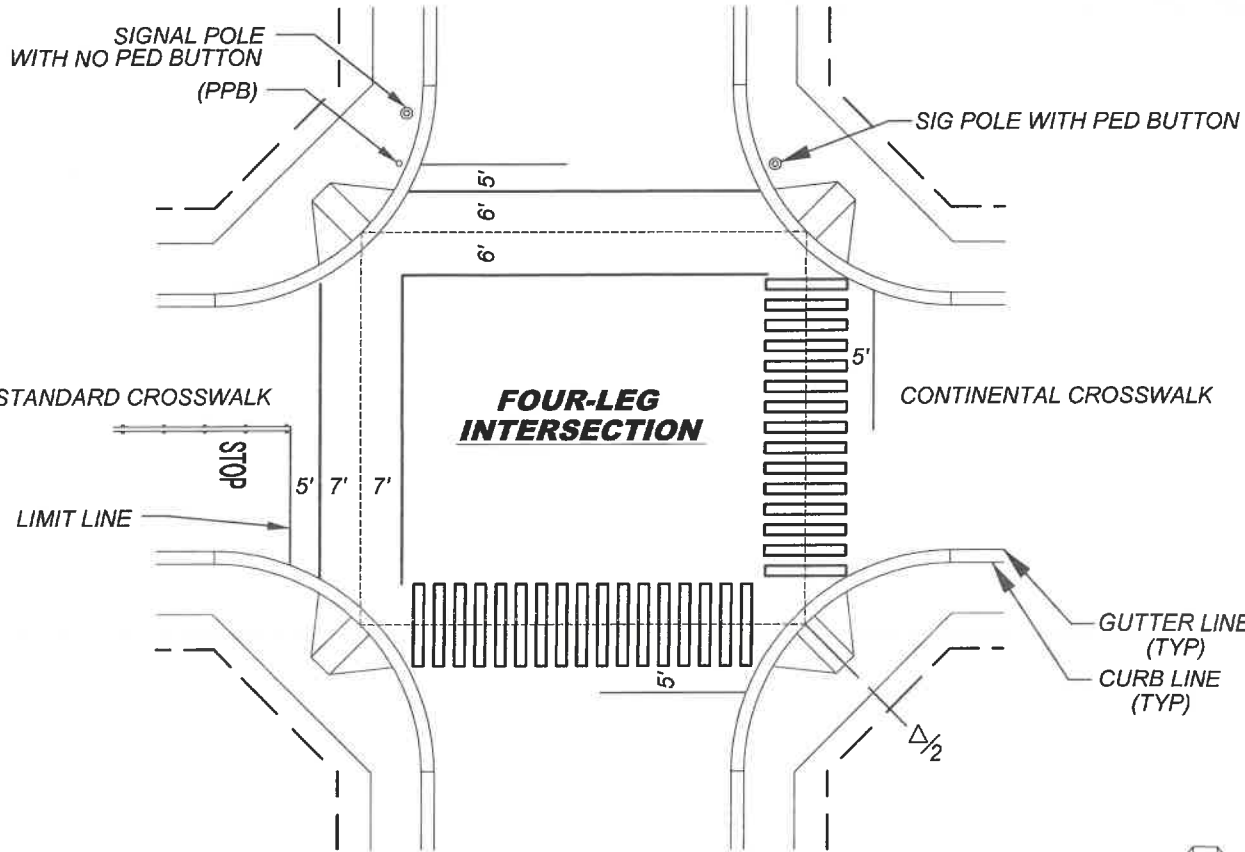

**FOUR-LEG INTERSECTION**

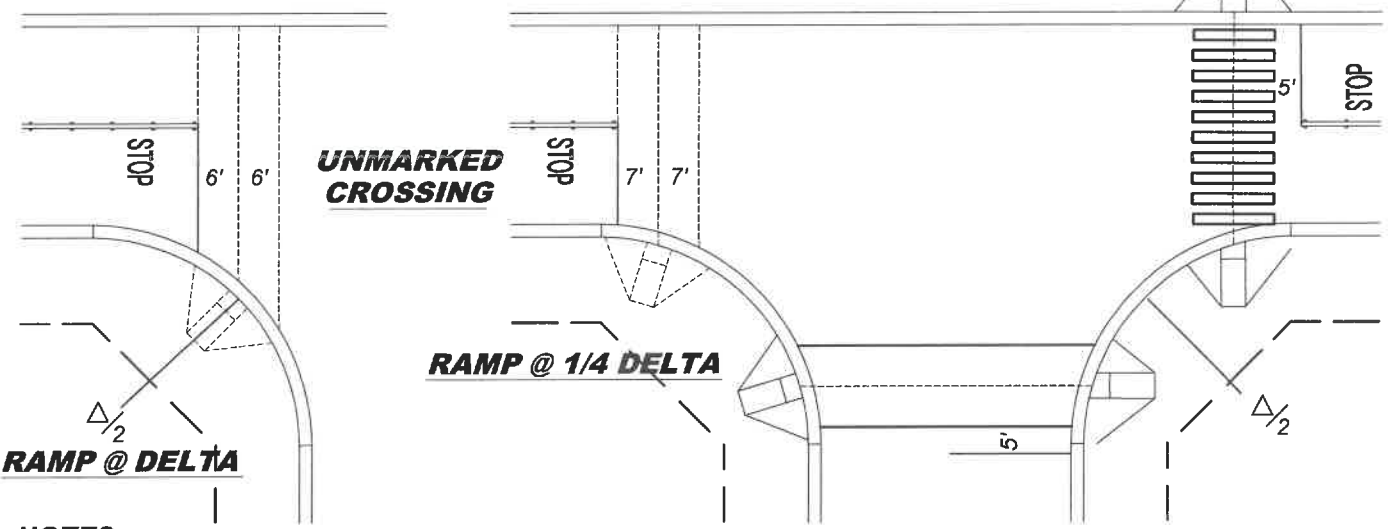

**"T" INTERSECTION**

**NOTES:**

- 1.) CROSSWALK WIDTHS:  
 MINIMUM 10' (INSIDE TO INSIDE) CROSSWALK FOR ROAD WIDTH 44' OR LESS.  
 MINIMUM 12' (INSIDE TO INSIDE) CROSSWALK FOR ROAD WIDTH MORE THAN 44'.
- 2.) PEDESTRIAN PUSH BUTTON SHALL BE LOCATED NOT MORE THAN 5' FROM CROSSWALK. SEPARATE PUSH BUTTON POSTS (PPB) SHALL BE INSTALLED WHEN THE SIGNAL POLES ARE MORE THAN 5' FROM CROSSWALK.
- 3.) STOP BAR AND CROSSWALK SHALL BE THERMOPLASTIC, LOCATION TO BE DETERMINED IN FIELD.
- 4.) THE CITY ENGINEER WILL DETERMINE CROSSWALK LOCATION AND/OR WIDTH THAT VARY FROM THIS STANDARD.

NOT TO SCALE

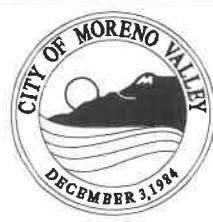

RECOMMENDED:  
*Wers* 10/3/24  
 DIVISION MANAGER DATE  
 APPROVED:  
*Melissa Madec* 10/8/24  
 PUBLIC WORKS DIRECTOR / DATE  
 CITY ENGINEER

**CITY OF MORENO VALLEY**

PUBLIC WORKS DEPARTMENT - TRANSPORTATION ENGINEERING DIVISION

**CROSSWALK LOCATION**

STANDARD PLAN  
**MVLT-432-1**

# CONTINENTAL CROSSWALK PLACEMENT

## TYPICAL CONTINENTAL MARKINGS

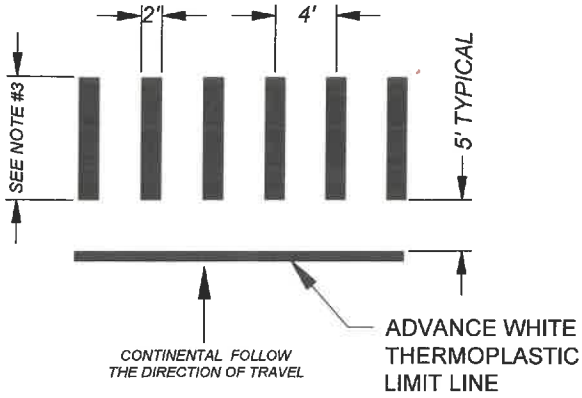

## CONCRETE CROSS-GUTTER INTERSECTION

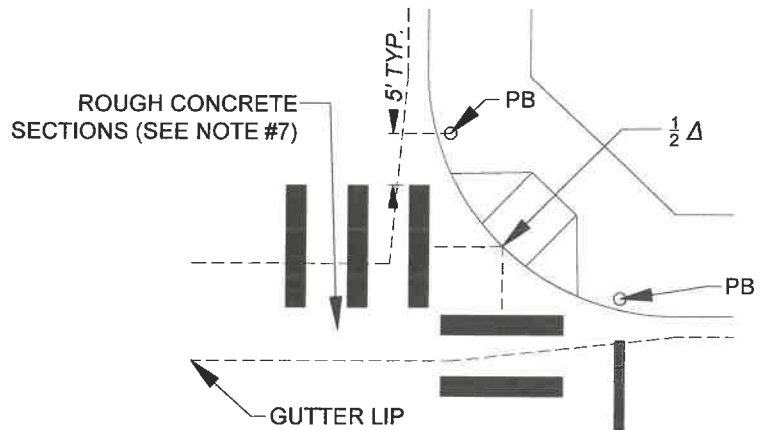

## SINGLE RAMP CORNER

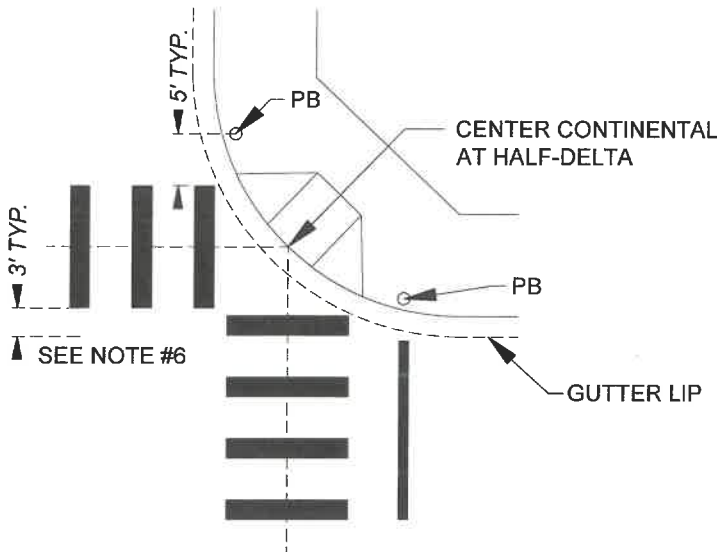

## DUAL RAMP CORNER

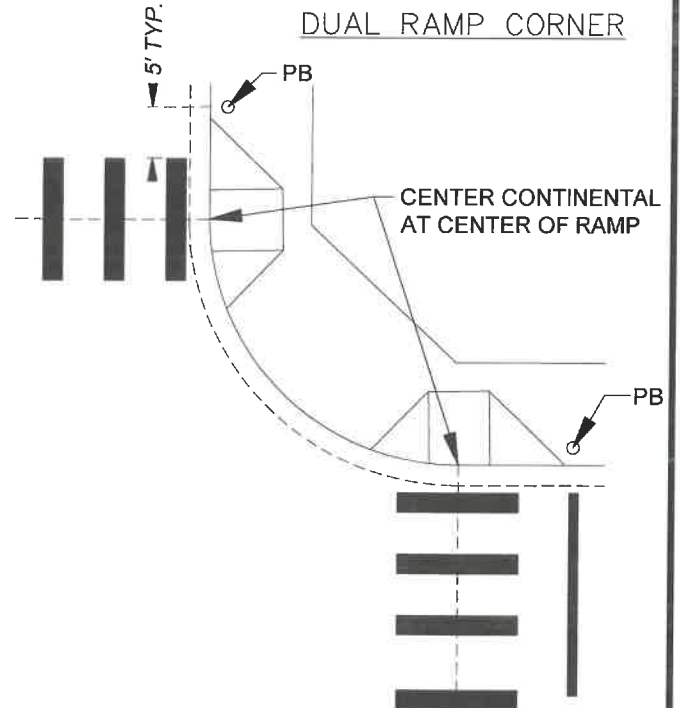

### GENERAL NOTES:

1. CONTINENTAL CROSSWALKS SHALL BE ALIGNED PARALLEL TO THE DIRECTION OF VEHICLE TRAVEL.
2. ADVANCE THERMOPLASTIC 12" WHITE LIMIT LINE PLACEMENT SHALL BE INSTALLED 5FT FOR THE APPROACH LANES LEADING TO CONTROLLED INTERSECTION CROSSINGS.
3. CONTINENTAL CROSSWALKS SHALL BE 10FT WIDE FOR ROADWAYS WIDTH OF 44 OR LESS AND 12FT WIDE FOR ROADWAYS GREATER THAN 44FT; UNLESS WIDTH IS SPECIFIED ON PLAN BY CITY ENGINEER.
4. CONTINENTAL CROSSWALKS SHALL BE IN THERMOPLASTIC WHITE UNLESS NOTED THERMOPLASTIC YELLOW FOR SCHOOL CROSSING.
5. CONTINENTAL CROSSWALKS SHALL BE INSTALLED WITH RETROREFLECTIVITY COMPLIANT AND SKID RESISTANT.
6. CONTINENTAL CROSSWALK SHALL NOT IMPEDE INTO THE INTERSECTION OR OPPOSING DIRECTION OF VEHICLE TRAVEL. SEE DETAIL "SINGLE RAMP CORNER" SHOWING 3FT SET-BACK FROM GUTTER LIP.
7. ALL THERMOPLASTIC INSTALLATION ON TOP OF CONCRETE SURFACE MUST HAVE CONCRETE WATER BLASTED TO ROUGH UP CONCRETE SURFACE BEFORE APPLYING PRIMER APPLICATION AND THERMOPLASTIC MARKING, AS DIRECTED BY ENGINEER.

NOT TO SCALE

	RECOMMENDED: <i>W. J. S. 8/10/22</i> DIVISION MANAGER      DATE	<h2 style="margin: 0;">CITY OF MORENO VALLEY</h2> PUBLIC WORKS DEPARTMENT - TRANSPORTATION ENGINEERING DIVISION
	APPROVED: <i>[Signature]</i> 8/15/22 PUBLIC WORKS DIRECTOR / DATE CITY ENGINEER	<h3 style="margin: 0;">CONTINENTAL CROSSWALK AND ADVANCE LIMIT LINE PLACEMENT</h3>

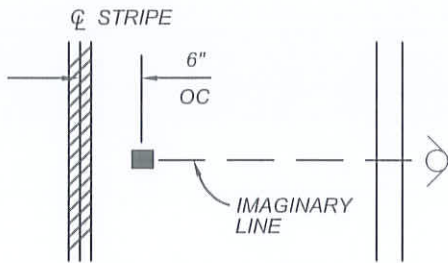

UNMARKED STREETS: PLACE MARKER 6" FROM EDGE OF IMAGINARY LINE OF STREET ON HYDRANT SIDE.

MARKED STREETS: PLACE MARKER 6" FROM CENTERLINE OF PAINTED LINE TO CENTERLINE OR MARKER ON HYDRANT SIDE.



**NOTES:**

- 1.) THE REFLECTIVE SIDE SHALL FACE THE FLOW OF TRAFFIC.
- 2.) THE "BLUE DOT" SHALL BE IN LINE WITH THE FIRE HYDRANT, EXCEPT WHERE TWO (2) DOTS ARE USED FOR INTERSECTIONS.
- 3.) A BLUE REFLECTIVE MARKER WILL BE PLACED 6" FROM THE CENTER OF THE PAINTED LINES AS PER PLACEMENT STD MVL-440B-0 OR MVL-440C-0 AS APPLICABLE. IF NO TRAFFIC LINE EXIST, PLACE BLUE DOT 6" FROM CENTER OF THE STREET ON THE FIRE HYDRANT SIDE. (SEE STANDARD PLACEMENT DETAIL HEREON.)
- 4.) IF A PAINTED TRAFFIC LIMIT LINE FOR STOP SIGNS EXISTS, PLACE THE SECOND "BLUE DOT" 2 FEET BACK FROM LINE, 6" ON CENTER FROM PAINTED TRAFFIC LIMIT LINE (SEE STD MVL-440B-0, "STREET INTERSECTION")
- 5.) IF NO TRAFFIC LIMIT LINE FOR STOP SIGNS EXISTS, PLACE "BLUE DOT" IN LINE WITH SIDEWALK EDGE ON THE SIDE CLOSEST TO THE PROPERTY LINE, 6" ON CENTER FROM THE CENTER OF THE STREET LINE (SEE STD MVL-440B-0, "STREET INTERSECTION").
- 6.) THE "BLUE DOT" SHALL BE APPLIED USING HOT MELT BITUMINOUS ADHESIVE. THE MARKER SHALL BE APPLIED TO A DRY, DIRT FREE STREET AND ENOUGH ADHESIVE SHALL BE APPLIED SO THAT SOME ADHESIVE OOZES OUT AROUND THE EDGES OF THE "BLUE DOT".

NOT TO SCALE

	RECOMMENDED: <i>EL</i> DIVISION MANAGER DATE: <i>1/22/14</i>	<b>CITY OF MORENO VALLEY</b> PUBLIC WORKS DEPARTMENT - TRANSPORTATION ENGINEERING DIVISION
	APPROVED:  PUBLIC WORKS DIRECTOR / DATE: <i>1/29/14</i> CITY ENGINEER	<b>"BLUE DOT" TYPE I          MARKER PLACEMENT NOTES</b>



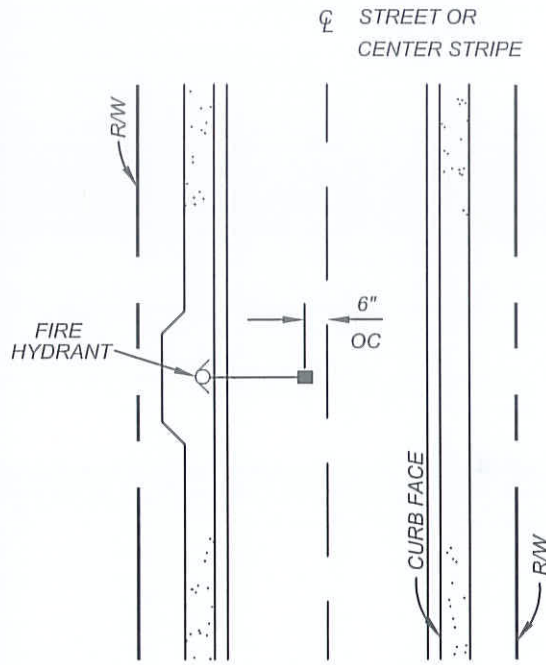

TWO LANE STREET

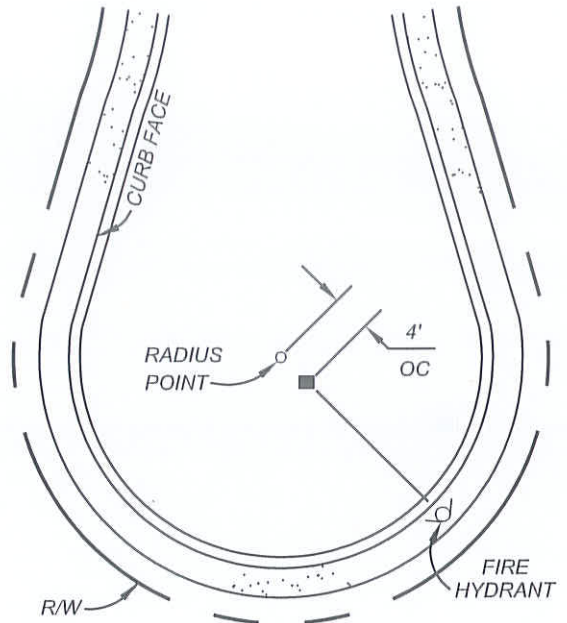

CUL-DE-SAC

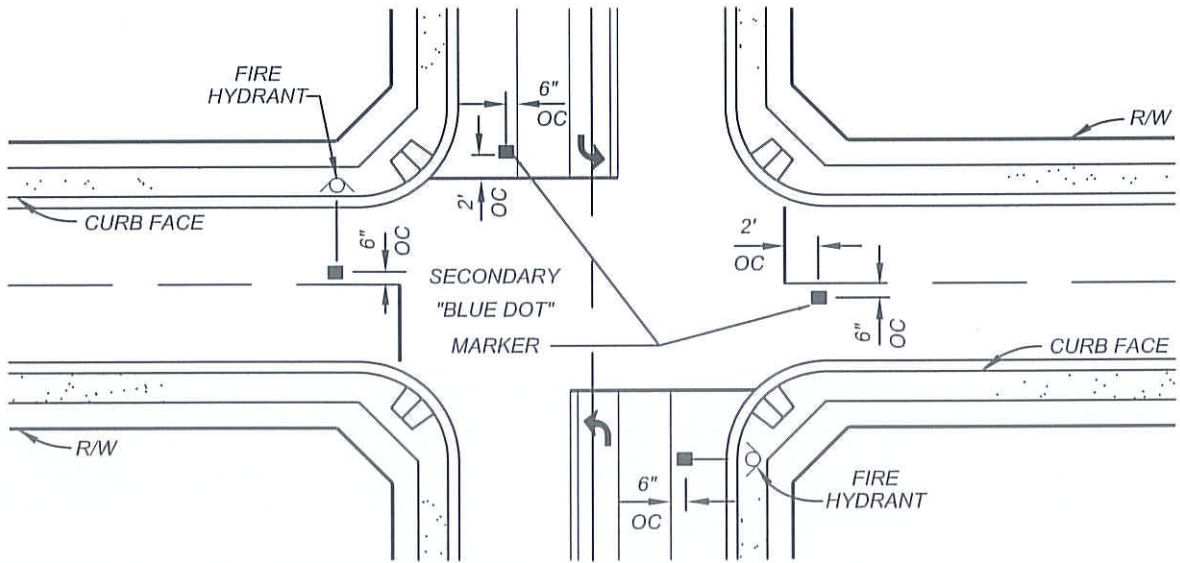

STREET INTERSECTION

**NOTE:**

1.) FOR NOTES REGARDING "BLUE DOT" MARKER PLACEMENT, SEE STD PLAN MVL-440A-0

NOT TO SCALE

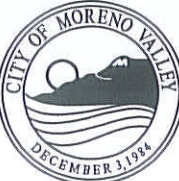
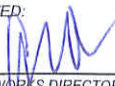
	RECOMMENDED: <i>EL</i> DIVISION MANAGER DATE: <i>1/21/14</i>	<b>CITY OF MORENO VALLEY</b> PUBLIC WORKS DEPARTMENT - TRANSPORTATION ENGINEERING DIVISION	
	APPROVED:  PUBLIC WORKS DIRECTOR / CITY ENGINEER DATE: <i>1/29/14</i>	<b>"BLUE DOT" TYPE I MARKER          PLACEMENT          INTERSECTION &amp; CUL-DE-SAC</b>	



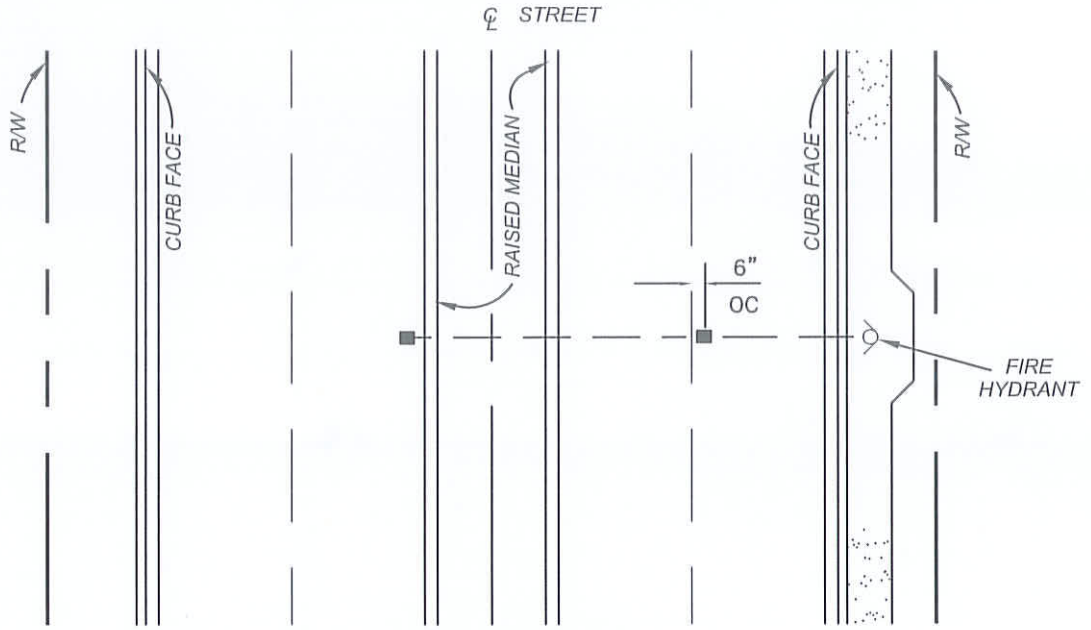

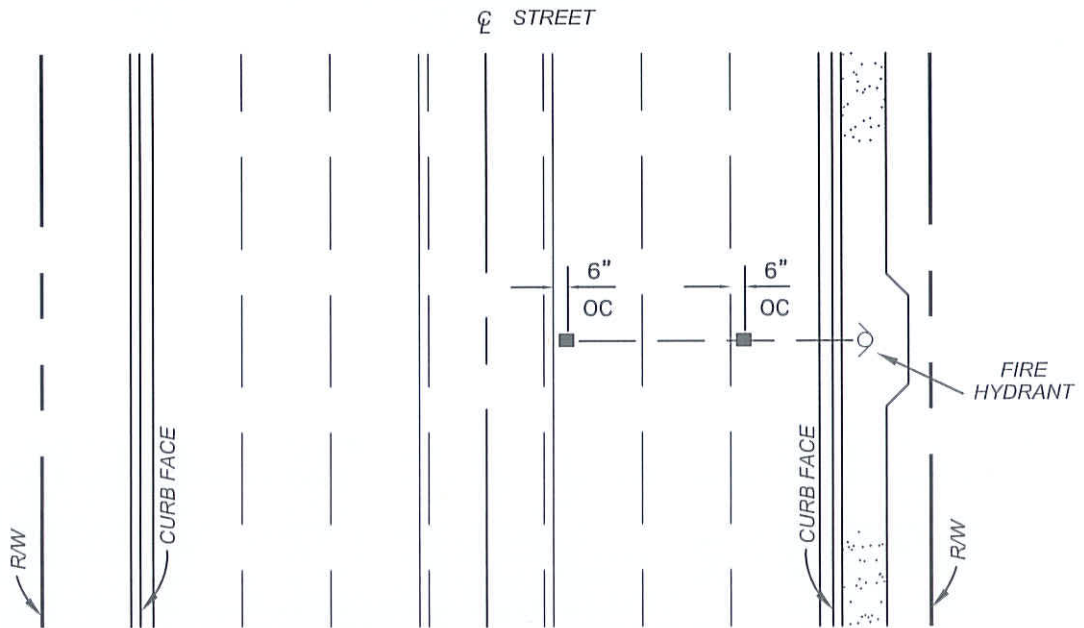

**DIVIDED STREET**



**NOTE:** **STREET WITH TURN LANE**

1.) FOR NOTES REGARDING "BLUE DOT" MARKER PLACEMENT, SEE STD PLAN MVL-440A-0

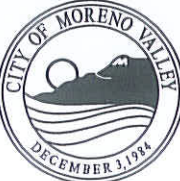
NOT TO SCALE

	RECOMMENDED: <i>EL</i> DIVISION MANAGER DATE: <i>1/22/14</i>	<b>CITY OF MORENO VALLEY</b> PUBLIC WORKS DEPARTMENT - TRANSPORTATION ENGINEERING DIVISION	
	APPROVED:  PUBLIC WORKS DIRECTOR / DATE CITY ENGINEER / <i>1/29/14</i>	<b>"BLUE DOT" TYPE I MARKER PLACEMENT</b> <b>DIVIDED STREET &amp;</b> <b>STREET WITH TURN LANE</b>	

**NOTES:**

- 1.) WORK SHALL BE PER CALTRANS STANDARD PLANS ES-5A AND ES-5B EXCEPT AS SHOWN HEREON.
- 2.) LOOP SPACING SHALL BE 10' APART, WITH FIRST LOOP INSTALLED 1' INTO THE CROSSWALK OR LIMIT LINE.
- 3.) LOOPS SHALL BE CENTERED IN THE TRAVELED PORTION OF THE LANE UNLESS OTHERWISE SHOWN ON THE PLANS.
- 4.) THERE SHALL BE NO MORE THAN TWO LOOPS PER HOMERUN.
- 5.) LOOP WIRE SHALL BE TYPE "2" WIRE.
- 6.) LOOP WIRE SHALL BE ONE CONTINUOUS PIECE OF WIRE FROM THE PULL BOX THROUGH THE LOOP BACK TO THE PULL BOX. NO SPLICING WILL BE ALLOWED IN THE LOOP WIRE IN THE STREET. SPLICING IS PERMITTED AT THE PULL BOX ONLY.
- 7.) WHEN POSSIBLE, LOOPS WILL BE PLACED IN THE BASE COURSE OF PAVING. NO MORE THAN 2 TWISTED PAIRS SHALL BE INSTALLED IN ONE SAWED SLOT.
- 8.) SAWCUTS SHALL BE BACK FILLED USING "HOT MELT RUBBERIZED ASPHALT" AND NO OTHER BACKFILL MATERIAL SHALL BE USED.
- 9.) SEE STD PLAN MVL-450C-0 FOR ADDITIONAL REQUIREMENTS

**TYPICAL SAW CUT**

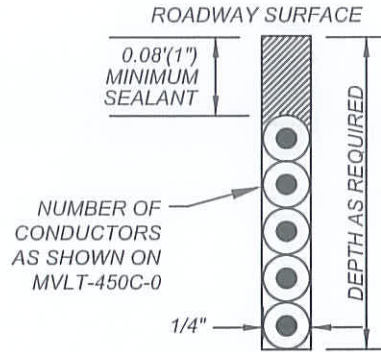

**ADVANCE/COUNT**

DIRECTION OF TRAVEL →

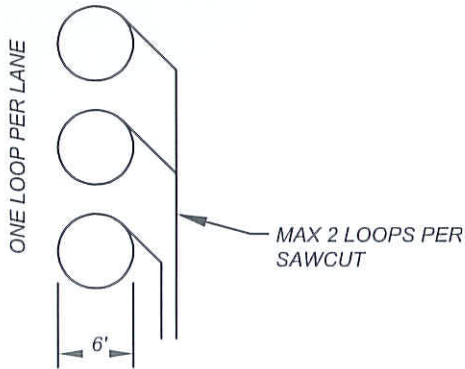

**THRU LANES**

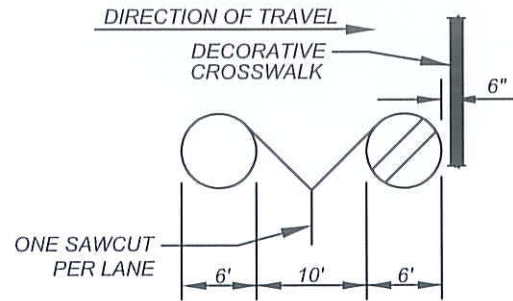

**LEFT TURN LANES**

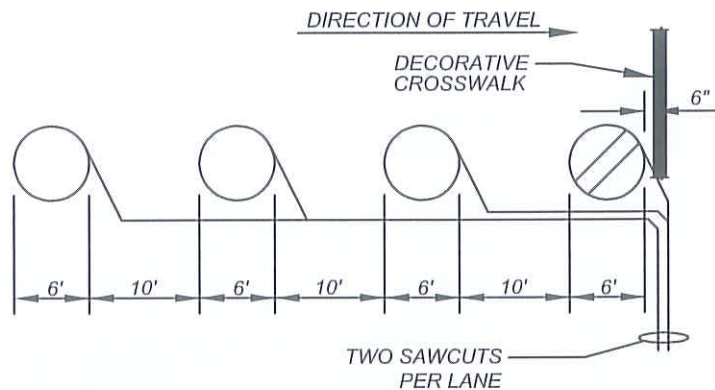

**LEGEND**

- TYPE "E" LOOP PER CALTRANS STD PLAN ES-5B
- CALTRANS TYPE "D" LOOP (MODIFIED)—SAWCUT TYPE "E" LOOP AND TRISECT WITH TWO STRAIGHT SAWCUTS @ 21" OC, ORIENTED AT 45° RELATIVE TO DIRECTION OF TRAVEL

NOT TO SCALE

	RECOMMENDED:  DIVISION MANAGER      DATE 1/22/14	<h2 style="margin: 0;">CITY OF MORENO VALLEY</h2> <p style="margin: 0;">PUBLIC WORKS DEPARTMENT - TRANSPORTATION ENGINEERING DIVISION</p>	
	APPROVED:  PUBLIC WORKS DIRECTOR      DATE 1/27/14 CITY ENGINEER	<h3 style="margin: 0;">TRAFFIC INDUCTION LOOPS (DECORATIVE CROSSWALK)</h3>	

**NOTES:**

- 1.) WORK SHALL BE PER CALTRANS STANDARD PLANS ES-5A AND ES-5B EXCEPT AS SHOWN HEREON.
- 2.) LOOP SPACING SHALL BE 10' APART, WITH FIRST LOOP INSTALLED 1' INTO THE CROSSWALK OR LIMIT LINE.
- 3.) LOOPS SHALL BE CENTERED IN THE TRAVELED PORTION OF THE LANE UNLESS OTHERWISE SHOWN ON THE PLANS.
- 4.) THERE SHALL BE NO MORE THAN TWO LOOPS PER HOMERUN.
- 5.) LOOP WIRE SHALL BE TYPE "2" WIRE.
- 6.) LOOP WIRE SHALL BE ONE CONTINUOUS PIECE OF WIRE FROM THE PULL BOX THROUGH THE LOOP BACK TO THE PULL BOX. NO SPLICING WILL BE ALLOWED IN THE LOOP WIRE IN THE STREET. SPLICING IS PERMITTED AT THE PULL BOX ONLY.
- 7.) WHEN POSSIBLE, LOOPS WILL BE PLACED IN THE BASE COURSE OF PAVING. NO MORE THAN 2 TWISTED PAIRS SHALL BE INSTALLED IN ONE SAWED SLOT.
- 8.) SAWCUTS SHALL BE BACK FILLED USING "HOT MELT RUBBERIZED ASPHALT" AND NO OTHER BACKFILL MATERIAL SHALL BE USED.
- 9.) SEE STD MVL-450C-0 FOR ADDITIONAL REQUIREMENTS

**TYPICAL SAW CUT**

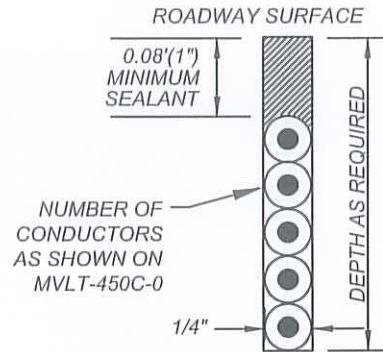

**ADVANCE/COUNT**

DIRECTION OF TRAVEL →

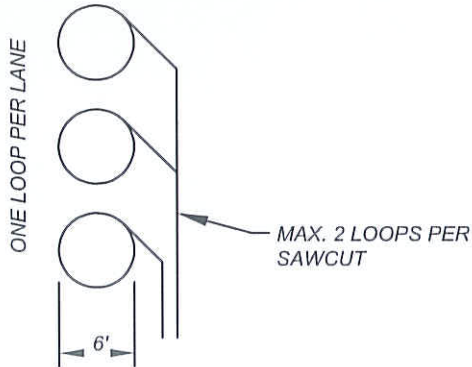

**THRU LANES**

DIRECTION OF TRAVEL →

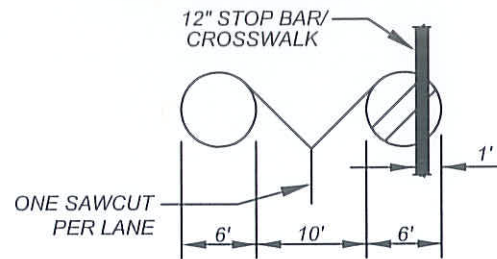

**LEFT TURN LANES**

DIRECTION OF TRAVEL →

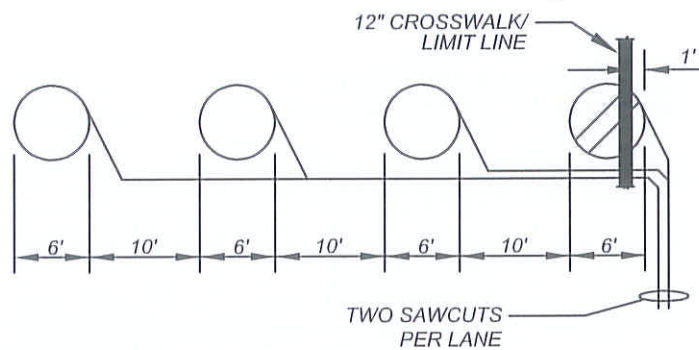

**LEGEND**

- TYPE "E" LOOP PER CALTRANS STD PLAN ES-5B
- CALTRANS TYPE "D" LOOP (MODIFIED)—SAWCUT TYPE "E" LOOP AND TRISECT WITH TWO STRAIGHT SAWCUTS @ 21" OC, ORIENTED AT 45° RELATIVE TO DIRECTION OF TRAVEL

NOT TO SCALE

	RECOMMENDED:  DIVISION MANAGER      DATE: 1/22/14	<b>CITY OF MORENO VALLEY</b> PUBLIC WORKS DEPARTMENT - TRANSPORTATION ENGINEERING DIVISION	STANDARD PLAN <b>MVL-450B-0</b>
	APPROVED:  PUBLIC WORKS DIRECTOR / DATE: 1/29/14 CITY ENGINEER	<b>TRAFFIC INDUCTION LOOPS</b> <b>(THERMOPLASTIC CROSSWALK)</b>	



**WINDINGS**

**TYPE "E" LOOP**

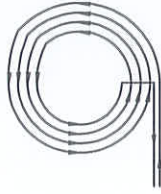

FOUR TURNS OF LOOP WIRE

**TYPE "D" LOOP (MOD)**

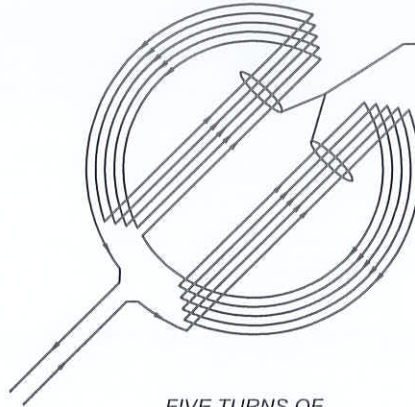

FIVE TURNS OF LOOP WIRE

DIRECTION OF CURRENT FLOW SHALL BE THE SAME IN THESE TWO SAWCUTS

**CONNECTIONS**

**TWO LOOPS IN LANE**

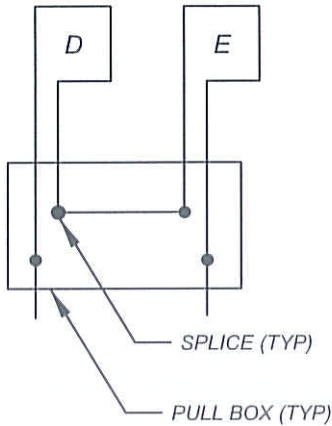

**FOUR LOOPS IN LANE**

**SERIES**

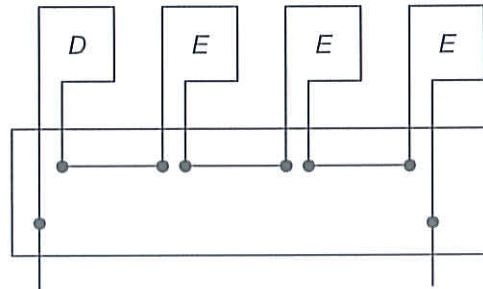

WIRING METHOD TO BE DETERMINED BY THE ENGINEER.

**SERIES/  
PARALLEL**

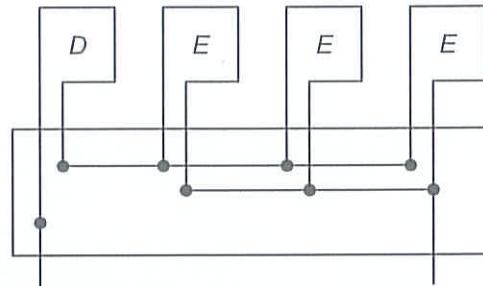

SEE STD PLAN MVL-450A-0 OR MVL-450B-0 (AS APPLICABLE) FOR ADDITIONAL REQUIREMENTS.

NOT TO SCALE

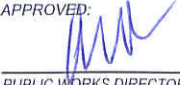
	RECOMMENDED: EL DIVISION MANAGER	1/21/14 DATE	<b>CITY OF MORENO VALLEY</b> PUBLIC WORKS DEPARTMENT - TRANSPORTATION ENGINEERING DIVISION	
	APPROVED:  PUBLIC WORKS DIRECTOR / CITY ENGINEER	1/29/14 DATE	<b>TRAFFIC INDUCTION LOOPS                  WIRING DETAILS</b>	



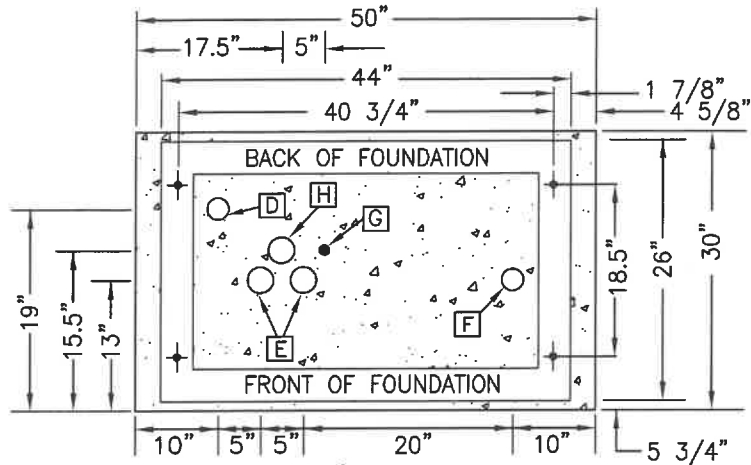

1.5"-2", ANCHOR BOLT;  
2"-4", CONDUIT;  
6", GROUND ROD

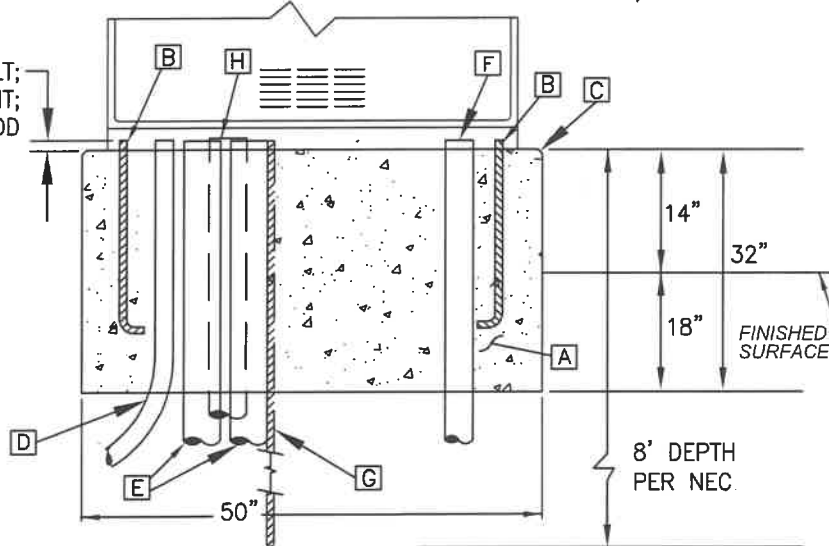

**CONSTRUCTION NOTES:**

- A 560-C-3250 PORTLAND CEMENT CONCRETE FOUNDATION
- B 3/4" x 18" GALVANIZED ANCHOR BOLTS (ASTM A307)
- C 3/8" CHAMFER TYPICAL
- D 2" SERVICE CONDUIT TO SERVICE ENCLOSURE
- E 4" SIGNAL CONDUCTOR CONDUITS TO ADJACENT PULL BOX
- F 2" CONDUIT FOR SIGNAL INTERCONNECT, PHONE OR FUTURE FIBER-OPTIC COMMUNICATION CABLE
- G GROUND ROD, 8 FT MIN INTO EARTH, EXCLUDING CONCRETE (APPROXIMATELY 10.5 FT ROD)
- H 3" CONDUIT FOR FUTURE CONDUCTORS

**GENERAL NOTES:**

1. INSTALL IN ACCORDANCE WITH CALTRANS STD PLAN ES-3C (NOTES 3, 7, AND 17 OF ES-4B MAY NOT APPLY).
2. FINAL LOCATION OF CONDUITS SHALL BE APPROVED PRIOR TO FOUNDATION POUR.
3. ALL CONDUITS IN CONTROLLER FOUNDATION SHALL BE SCHEDULE 80 PVC.
4. THE FOUNDATION SHALL BE CONSTRUCTED USING A STEEL FORM. THE CONCRETE SHALL BE VIBRATED. THE OUTSIDE EXPOSED FINISH SURFACE SHALL BE FREE OF VOIDS/HOLES AND SHALL BE TO THE SATISFACTION OF THE ENGINEER.

NOT TO SCALE



RECOMMENDED:

EL

7/3/19  
DATE

DIVISION MANAGER

APPROVED:

MZ. W... 7/30/19  
PUBLIC WORKS DIRECTOR / DATE  
CITY ENGINEER

**CITY OF MORENO VALLEY**

PUBLIC WORKS DEPARTMENT - TRANSPORTATION ENGINEERING DIVISION

**TYPE 333  
CONTROLLER CABINET  
FOUNDATION DETAIL**

STANDARD PLAN

**MVLT-460-0**

SHEET 1 OF 1

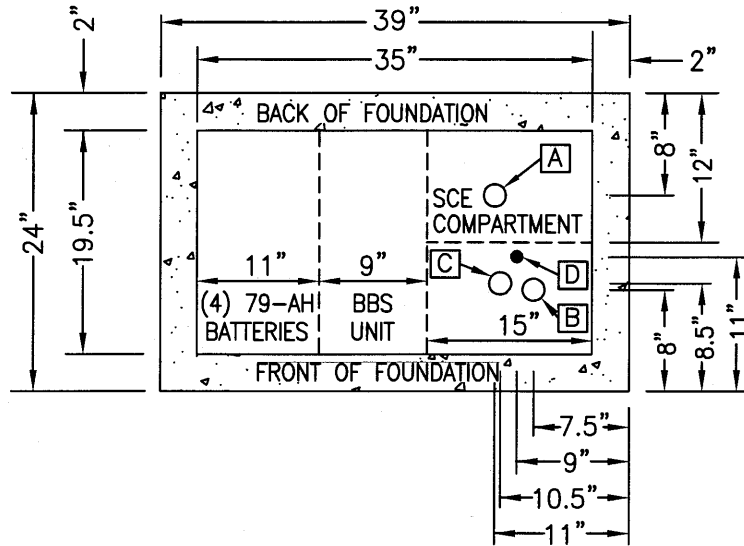

**FOUNDATION FOR MYERS**  
**MODEL MEUG35-UPS-M100TS (MOD)**

**CONSTRUCTION NOTES:**

- A** SCE 3" PVC CONDUIT
- B** 2" PVC CONDUIT TO CONTROLLER FOUNDATION
- C** 2" PVC CONDUIT TO #6 PULL BOX
- D** 8' GROUND ROD (COPPER)

**GENERAL NOTES:**

1. INSTALL IN ACCORDANCE WITH MYERS POWER PRODUCTS, INC SPECIFICATIONS
2. TOP OF 40"x24" FOUNDATION SHALL BE 3" ABOVE FINISHED SURFACE.
3. FINAL LOCATION OF CONDUITS SHALL BE APPROVED PRIOR TO FOUNDATION POUR.
4. THE FOUNDATION SHALL BE CONSTRUCTED USING A STEEL FORM. THE CONCRETE SHALL BE VIBRATED. THE OUTSIDE EXPOSED FINISH SURFACE SHALL BE FREE OF VOIDS/HOLES AND SHALL BE TO THE SATISFACTION OF THE ENGINEER.

NOT TO SCALE



RECOMMENDED:  
**EL** 1/12/17  
DIVISION MANAGER DATE

APPROVED:  
*[Signature]* 1/20/17  
PUBLIC WORKS DIRECTOR / DATE  
CITY ENGINEER

**CITY OF MORENO VALLEY**  
PUBLIC WORKS DEPARTMENT - TRANSPORTATION ENGINEERING DIVISION

**DUAL METER  
TRAFFIC SIGNAL  
SERVICE FOUNDATION**

STANDARD PLAN  
**MVLT-461-0**

SHEET 1 OF 1

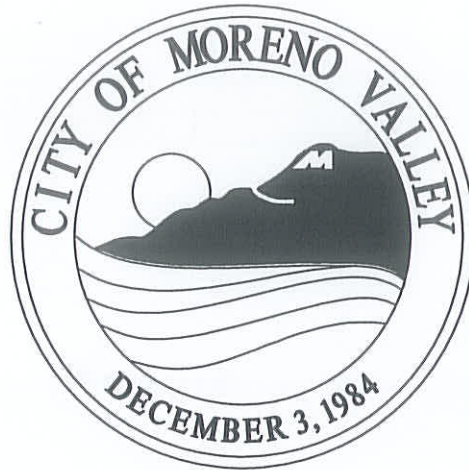

# **CITY OF MORENO VALLEY STANDARD PLANS**

## **SECTION 5**

# LANDSCAPING AND IRRIGATION SYSTEMS

# City of Moreno Valley

## Standard Plans Index - 2022 Edition

---

### **SECTION 4: Street Light and Traffic (Continued)**

MVL-450C-0	<i>Traffic Induction Loops Wiring Details</i>
MVL-460-0	<i>Type 333 Controller Cabinet Foundation Detail</i>
MVL-461-0	<i>Dual Meter Traffic Signal Service Foundation</i>

**Note:** *Various State's Standards for Street Light and Traffic may be used subject to review and approval from the Public Works Director/City Engineer.*

### **SECTION 5: Landscaping and Irrigation Systems**

#### Landscaping

MVL-500A-0	<i>Palm Tree Planting (Special Districts)</i>
MVL-500B-1	<i>Palm Tree Planting (Parks &amp; CS)</i>
MVL-501A-0	<i>Container Planting (Special Districts)</i>
MVL-501B-1	<i>Container Planting (Shrub Beds) (Parks &amp; CS)</i>
MVL-501C-0	<i>Container Planting on Slope (Special Districts)</i>
MVL-501D-1	<i>Container Planting on Slope (Parks &amp; CS)</i>
MVL-502-1	<i>Native Shrub Planting/On Slope Shrub Planting (Parks &amp; CS)</i>
MVL-503A-0	<i>Vine Detail: Non-Adhering Type (Special Districts)</i>
MVL-503B-0	<i>Vine Detail: Adhering Type (Parks &amp; CS)</i>
MVL-504-0	<i>Tree Spacing Requirements (Special Districts)</i>
MVL-505A-0	<i>Shrub/Groundcover Spacing (Special Districts)</i>
MVL-505B-0	<i>Shrub/Groundcover Spacing (Parks &amp; CS)</i>
MVL-510A-0	<i>Tree Guying Detail - 36" Box or Larger (Special Districts)</i>
MVL-510B-1	<i>Tree Guying Detail - 36" Box or Larger (Parks &amp; CS)</i>
MVL-511A-0	<i>Typical Double Stake Tree (15 Gal. - 24" Box) (Special Districts)</i>
MVL-511B-1	<i>Typical Double Stake Tree (Parks &amp; CS)</i>
MVL-511C-1	<i>Steel Double Stake Tree (Parks &amp; CS)</i>
MVL-511D-0	<i>Double Stake Tree on Slope (Special Districts)</i>
MVL-511E-1	<i>Double Stake Tree on Slope (Parks &amp; CS)</i>
MVL-512A-0	<i>Triple Stake Tree (Special Districts)</i>
MVL-512B-1	<i>Triple Stake Tree (Parks &amp; CS)</i>
MVL-512C-0	<i>Triple Stake Tree on Slope (Special Districts)</i>
MVL-512D-1	<i>Triple Stake Tree on Slope (Parks &amp; CS)</i>
MVL-520A-0	<i>Mulch Installation (Special Districts)</i>
MVL-520B-0	<i>Bark Installation (Parks &amp; CS)</i>
MVL-521-0	<i>2" x 4" Redwood Header (Special Districts)</i>
MVL-522A-0	<i>6" Wide Concrete Mow Curb (Special Districts)</i>
MVL-522B-0	<i>6" Wide Concrete Mow Curb (Parks &amp; CS)</i>
MVL-522C-0	<i>12" Wide Concrete Mow Curb (Parks &amp; CS)</i>
MVL-523A-0	<i>Erosion Control Netting (Landscaping) (Special Districts)</i>
MVL-523B-0	<i>Erosion Control Netting (Landscaping) (Parks &amp; CS)</i>
MVL-524A-0	<i>Linear Root Barrier (Special Districts)</i>
MVL-524B-0	<i>Linear Root Barrier (Parks &amp; CS)</i>



# City of Moreno Valley

## Standard Plans Index - 2022 Edition

---

### **SECTION 5:      Landscaping and Irrigation Systems (Continued)**

#### Irrigation

MVLI-530-0	CCU Radio Link Antenna & Enclosure Detail (Special Districts)
MVLI-531A-0	Controller / Satellite Enclosure Detail (Special Districts)
MVLI-531B-0	Smart Controller Enclosure Detail (Parks & CS)
MVLI-532-0	CCU Enclosure Detail (Special Districts)
MVLI-533-0	External Ground Rod Assembly Detail (Special Districts)
MVLI-534-0	LEIT XRC Irrigation Controller (Parks & CS)
MVLI-535-0	Multiple Controllers Using One ET Gage (Parks & CS)
MVLI-536-0	Typical Transient Protection Installation (Parks & CS)
MVLI-537-0	Vandal Resistant ET Gage Enclosure (Parks & CS)
MVLI-538-0	Irrigation Controller Grounding Instruction (Parks & CS)
MVLI-539-0	Irrigation Controller Enclosure Installation Detail (Parks & CS)
MVLI-540A-0	Flow Sensor Assembly Detail (Special Districts)
MVLI-540B-0	Flow Sensor Assembly Detail (Parks & CS)
MVLI-540C-0	FMBX Flow Meter Installation (Parks & CS)
MVLI-541-0	Rain Gauge / Weather Sensor Installation Detail (Parks & CS)
MVLI-542A-0	Telemetry Pull-Box Assembly Detail (Special Districts)
MVLI-542B-0	Telemetry Pull-Box Assembly Detail (Parks & CS)
MVLI-543A-0	Master Valve Assembly Detail (Special Districts)
MVLI-543B-0	Master Valve Assembly Detail (Parks & CS)
MVLI-543C-0	Master Valve and Flow Meter Installation (Parks & CS)
MVLI-544A-0	Toe Nipple Assembly (Special Districts)
MVLI-544B-0	Toe Nipple Assembly (Parks & CS)
MVLI-545A-0	Irrigation Wire Connector (Special Districts)
MVLI-545B-0	Irrigation Wire Connector (Parks & CS)
MVLI-545C-0	Irrigation Control Wire Notes (Parks & CS)
MVLI-546-0	Irrigation Booster Pump Detail (Special Districts)
MVLI-547A-0	Reduced Pressure Backflow Preventer (Special Districts)
MVLI-547B-1	Backflow Preventer (Parks and CS)
MVLI-548A-0	Backflow Preventer Enclosure (Special Districts)
MVLI-548B-0	Single Backflow Cover (Parks and CS)
MVLI-548C-0	Double Backflow Cover (Parks and CS)
MVLI-550A-0	Pressure Reducing Valve (Special Districts)
MVLI-550B-0	Pressure Reducing Valve (Parks & CS)
MVLI-551A-0	Ball Valve/Gate Valve - 3" Or Smaller (Special Districts)
MVLI-551B-0	Ball Valve/Gate Valve - 3" Or Smaller (Parks & CS)
MVLI-552A-0	Remote Control Valve with Union (Special Districts)
MVLI-552B-0	Remote Control Valve Detail (Parks and CS)
MVLI-553A-0	Remote Control Valve for Drip Systems (Special Districts)
MVLI-553B-0	Remote Control Valve Detail for Drip Systems (Parks & CS)
MVLI-554A-0	Quick Coupling Valve (Special Districts)
MVLI-554B-0	Quick Coupling Ball Valve (Parks & CS)
MVLI-555A-0	Air Vacuum Relief Valve (Special Districts)
MVLI-555B-0	Air Vacuum Relief Valve (Parks & CS)

# City of Moreno Valley

## Standard Plans Index - 2022 Edition

---

**SECTION 5:      Landscaping and Irrigation Systems (Continued)**

MVLI-556A-0	<i>Irrigation Stub-Out Box (Special Districts)</i>
MVLI-556B-0	<i>Irrigation Stub-Out Box (Parks &amp; CS)</i>
MVLI-560A-0	<i>Landscape Trench Detail (Special Districts)</i>
MVLI-560B-0	<i>Trench Detail (Parks &amp; CS)</i>
MVLI-561A-0	<i>Sleeving Detail (Special Districts)</i>
MVLI-561B-0	<i>Sleeving Detail (Parks &amp; CS)</i>
MVLI-562-0	<i>Median and Parkway Irrigation Line Installation (Special Districts)</i>
MVLI-563A-0	<i>Deep Well Tree Irrigation (Special Districts)</i>
MVLI-563B-0	<i>Deep Well Tree Irrigation (Parks &amp; CS)</i>
MVLI-564-0	<i>Drip Emitter Installation (Special Districts)</i>
MVLI-565-0	<i>Tree Well Sump (Parks &amp; CS)</i>
MVLI-566-0	<i>Rainbird RWS-BCG02 Root Watering System (Parks &amp; CS)</i>
MVLI-570A-0	<i>6" Pop-up Spray Head (Special Districts)</i>
MVLI-570B-0	<i>12" Pop-up Spray Head (Special Districts)</i>
MVLI-570C-0	<i>6" or 12" Pop-up Spray Head (Parks &amp; CS)</i>
MVLI-571A-0	<i>Pop-up Rotary Head (Special Districts)</i>
MVLI-571B-0	<i>Pop-up Rotary Head (Parks &amp; CS)</i>
MVLI-572-0	<i>Rotor Installation on Fixed Riser (Special Districts)</i>
MVLI-573-0	<i>Rainbird 1800 Sam PRS Pop Up Spray Head (Parks &amp; CS)</i>
MVLI-574A-0	<i>Dripperline (With Integrated Check Valves) Center Feed Layout (Special Districts)</i>
MVLI-574B-0	<i>Dripperline (With Integrated Check Valves) Center Feed Layout (Parks &amp; CS)</i>
MVLI-574C-0	<i>Dripperline (Recycled Water Systems) Center Feed Layout (Special Districts)</i>
MVLI-574D-0	<i>Dripperline (Recycled Water Systems) Center Feed Layout (Parks &amp; CS)</i>
MVLI-574E-0	<i>PVC Pipe with Swing-Joint Connection to Dripperline (Special Districts)</i>
MVLI-574F-0	<i>PVC Pipe with Swing-Joint Connection to Dripperline (Parks &amp; CS)</i>
MVLI-574G-0	<i>Manual Shut-Off / Flush Valve (For Dripperline) (Special Districts)</i>
MVLI-574H-1	<i>Manual Shut-Off / Flush Valve (For Dripperline) (Parks &amp; CS)</i>
MVLI-574I-0	<i>Automatic Flush Valve (For Dripperline) (Special Districts)</i>
MVLI-574J-0	<i>Automatic Flush Valve (For Dripperline) (Parks &amp; CS)</i>
MVLI-574K-0	<i>Air / Vacuum Relief Valve (For Dripperline) (Special Districts)</i>
MVLI-574L-1	<i>Air / Vacuum Relief Valve (For Dripperline) (Parks &amp; CS)</i>
MVLI-580A-0	<i>Thrust Blocks (Special Districts)</i>
MVLI-580B-0	<i>Thrust Blocks (Parks &amp; CS)</i>
MVLI-581-0	<i>Box Identification (Parks &amp; CS)</i>
MVLI-582-0	<i>Christy Tag (Parks &amp; CS)</i>



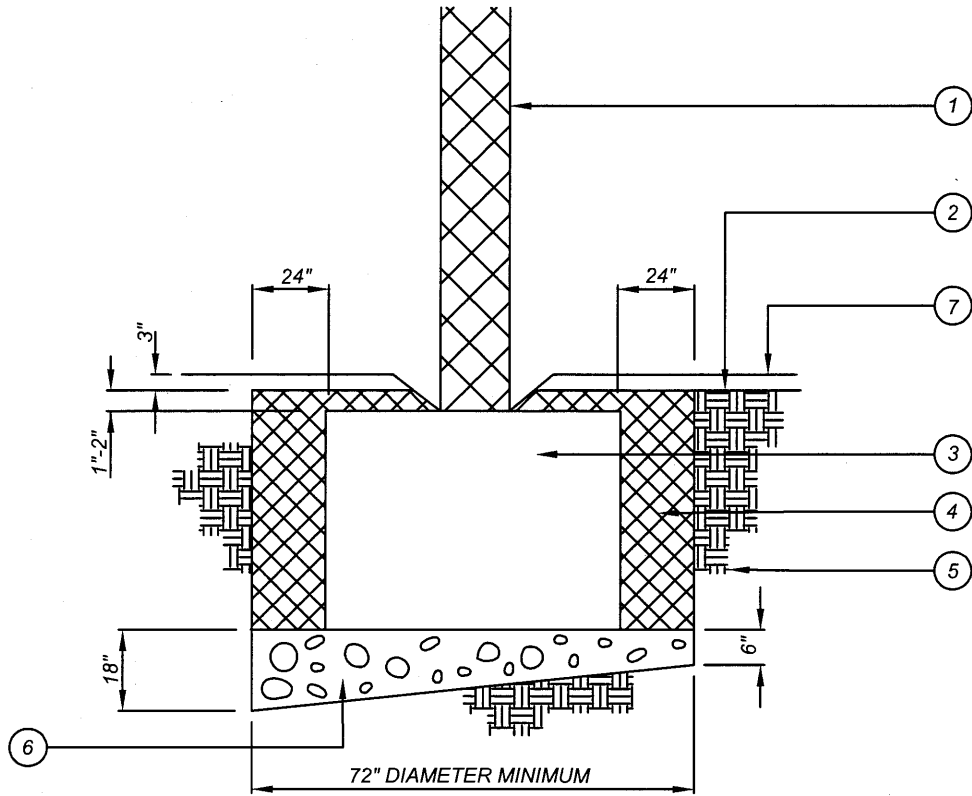





**LEGEND:**

- ① PALM TRUNK (SKINNED)
- ② FINISH GRADE
- ③ PALM ROOT BALL (TRIMMED)
- ④ WASHED PLASTER SAND BACKFILL
- ⑤ NATIVE SOIL
- ⑥ 3/4" WASHED CRUSHED AGGREGATE
- ⑦ 3" BARK OR DECOMPOSED GRANITE IN PLANTER BED

**NOTES:**

- 1.) ALL PALMS SHALL BE SKINNED & TIED PRIOR TO PLANTING, LEAVE TIED 90 DAYS MIN.
- 2.) SKINNED PALM TO HAVE 6-8 FRONDS OR PER CERTIFIED ARBORIST/PALM SPECIALIST.
- 3.) UPON INSTALLATION REPRESENTATIVES OF PARKS AND COMMUNITY SERVICES, LANDSCAPE ARCHITECT, LANDSCAPE CONTRACTOR SHALL DETERMINE IF PALMS REQUIRE GUYING.
- 4.) IRRIGATION PER PARKS & COMMUNITY SERVICES STANDARDS.
- 5.) CERTIFICATION OF GENUS AND SPECIES FOR ALL PALMS IS REQUIRED.

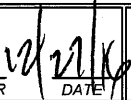
NOT TO SCALE

	RECOMMENDED: 	<h2 style="margin: 0;">CITY OF MORENO VALLEY</h2> <p style="margin: 0;">PARKS AND COMMUNITY SERVICES DEPARTMENT</p>	STANDARD PLAN <b>MVLI-500B-1</b>
	DIVISION MANAGER      DATE 	<h3 style="margin: 0;">PALM TREE PLANTING</h3>	SHEET 2 OF 2
APPROVED: 	PUBLIC WORKS DIRECTOR / DATE CITY ENGINEER		



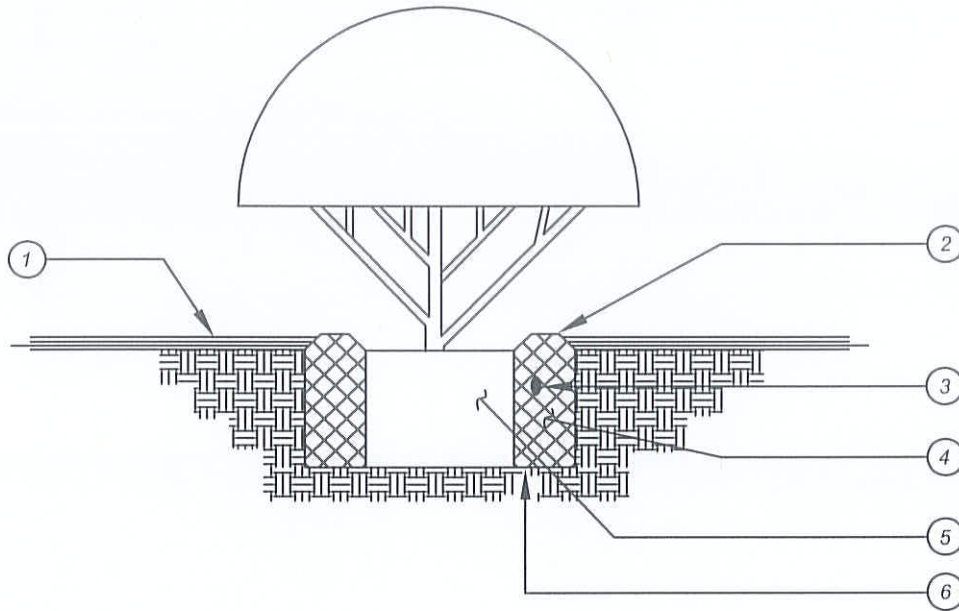



**LEGEND:**

- ① 3" THICK (MINIMUM) SHREDDED MULCH (PER PLAN AS SPECIFIED).
- ② 4" BERM TO FORM WATERING BASIN (BERM TO BE REMOVED PRIOR TO MULCH APPLICATION PER THE DISCRETION OF SPECIAL DISTRICTS).
- ③ PLANT TABS PER MANUFACTURER'S RECOMMENDATIONS.
- ④ BACKFILL MIX PER SPECIFICATIONS.
- ⑤ CONTAINER PLANT ROOT BALL.
- ⑥ PLANT PIT TO BE 2 TIMES THE WIDTH OF THE ROOT BALL & SAME DEPTH AS THE ROOT BALL.

**NOTES:**

- 1.) UNTANGLE MATTED ROOTS BY LOOSENING ALL ROOTS AT EDGE OF ROOT BALL WITH WATER FROM HOSE. DO NOT CRACK ROOT BALL.

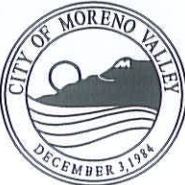
NOT TO SCALE

	RECOMMENDED: <i>COS</i> <i>1-16/14</i> <small>DIVISION MANAGER      DATE</small>	<h2 style="margin: 0;">CITY OF MORENO VALLEY</h2> <p style="margin: 0;">FINANCIAL &amp; MANAGEMENT SERVICES DEPARTMENT - SPECIAL DISTRICTS DIVISION</p>	<small>STANDARD PLAN</small> <b>MVLI-501A-0</b>
	APPROVED:  <small>PUBLIC WORKS DIRECTOR/      DATE</small> <small>CITY ENGINEER</small>	<h3 style="margin: 0;">CONTAINER PLANTING</h3>	<small>SHEET 1 OF 4</small>

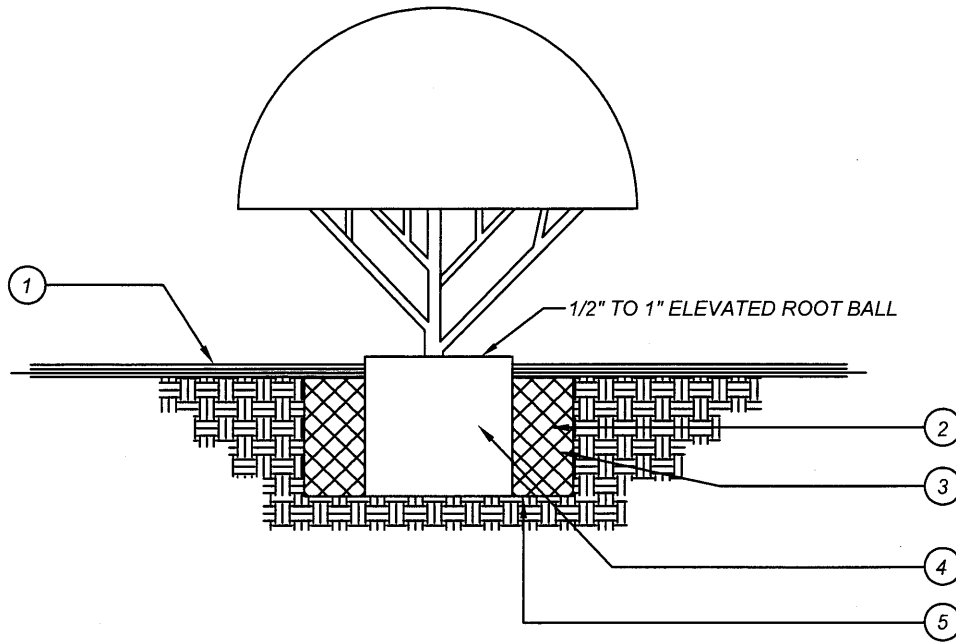

**LEGEND:**

- ① 3" THICK BARK OR DECOMPOSED GRANITE PER SPECIFICATIONS
- ② PLANT TABS PER MANUFACTURER'S RECOMMENDATIONS.
- ③ BACKFILL MIX PER SPECIFICATIONS.
- ④ CONTAINER PLANT ROOT BALL.
- ⑤ PLANT PIT TO BE 2 TIMES THE WIDTH OF THE ROOT BALL & SAME DEPTH AS THE ROOT BALL.

**NOTES:**

1.) UNTANGLE MATTED ROOTS BY LOOSENING ALL ROOTS AT EDGE OF ROOT BALL WITH WATER FROM HOSE. DO NOT CRACK ROOT BALL.

NOT TO SCALE

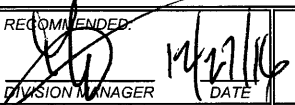
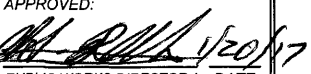
	RECOMMENDED:  DIVISION MANAGER      DATE	<h2 style="margin: 0;">CITY OF MORENO VALLEY</h2> <p style="margin: 0;">PARKS AND COMMUNITY SERVICES DEPARTMENT</p>	STANDARD PLAN <h3 style="margin: 0;">MVLI-501B-1</h3>
	APPROVED:  PUBLIC WORKS DIRECTOR / DATE CITY ENGINEER	<h3 style="margin: 0;">CONTAINER PLANTING ( SHRUB BEDS )</h3>	SHEET 2 OF 4

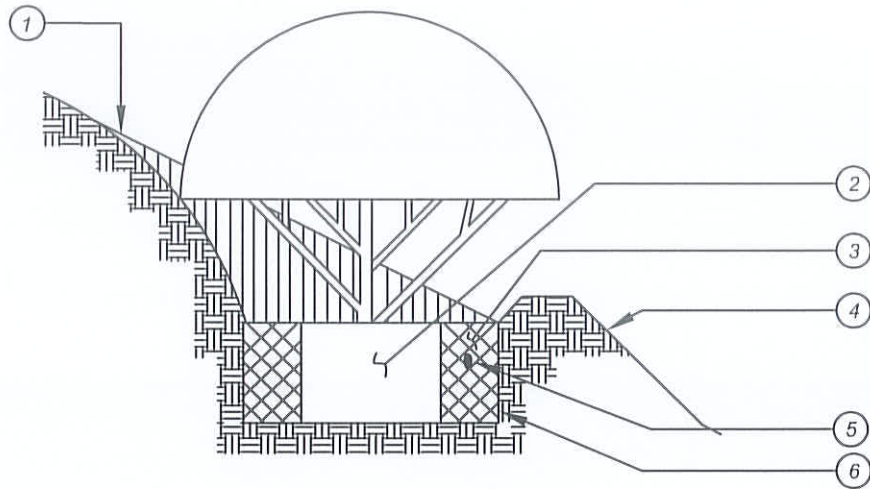

**LEGEND:**

- ① ORIGINAL GRADE.
- ② CONTAINER PLANT ROOT BALL.
- ③ BACKFILL MIX PER SPECIFICATIONS.
- ④ 4" BERM TIGHTLY COMPACTED IN PLACE TO FORM WATERING BASIN.
- ⑤ PLANT TABS PER MANUFACTURER'S RECOMMENDATIONS.
- ⑥ PLANTING PIT TO BE 2 TIMES THE WIDTH OF THE ROOT BALL & SAME DEPTH AS THE ROOT BALL.

NOT TO SCALE

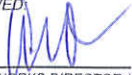
	RECOMMENDED: <i>CO5</i> <i>1-16-14</i> DIVISION MANAGER      DATE	<b>CITY OF MORENO VALLEY</b> FINANCIAL & MANAGEMENT SERVICES DEPARTMENT - SPECIAL DISTRICTS DIVISION	
	APPROVED:  <i>1/29/14</i> PUBLIC WORKS DIRECTOR / DATE CITY ENGINEER	<b>CONTAINER PLANTING ON SLOPE</b>	

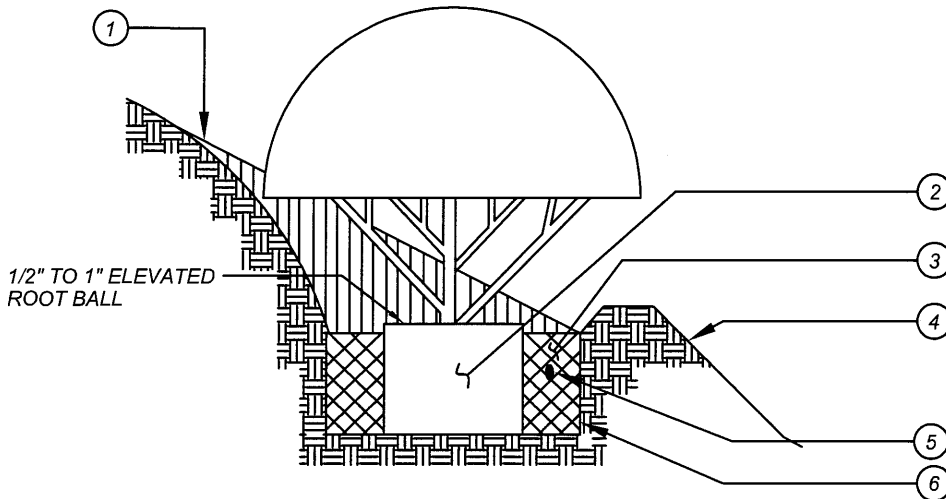

**LEGEND:**

- ① ORIGINAL GRADE.
- ② CONTAINER PLANT ROOT BALL.
- ③ BACKFILL MIX PER SPECIFICATIONS.
- ④ 4" BERM TIGHTLY COMPACTED IN PLACE TO FORM WATERING BASIN.
- ⑤ PLANT TABS PER MANUFACTURER'S RECOMMENDATIONS.
- ⑥ PLANTING PIT TO BE 2 TIMES THE WIDTH OF THE ROOT BALL & SAME DEPTH AS THE ROOT BALL.

NOT TO SCALE

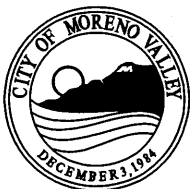

RECOMMENDED:  
*[Signature]* 12/27/16  
 DIVISION MANAGER DATE

APPROVED:  
*[Signature]* 1/20/17  
 PUBLIC WORKS DIRECTOR / DATE  
 CITY ENGINEER

**CITY OF MORENO VALLEY**

PARKS AND COMMUNITY SERVICES DEPARTMENT

**CONTAINER PLANTING  
ON SLOPE**

STANDARD PLAN

**MVLI-501D-1**

SHEET 4 OF 4



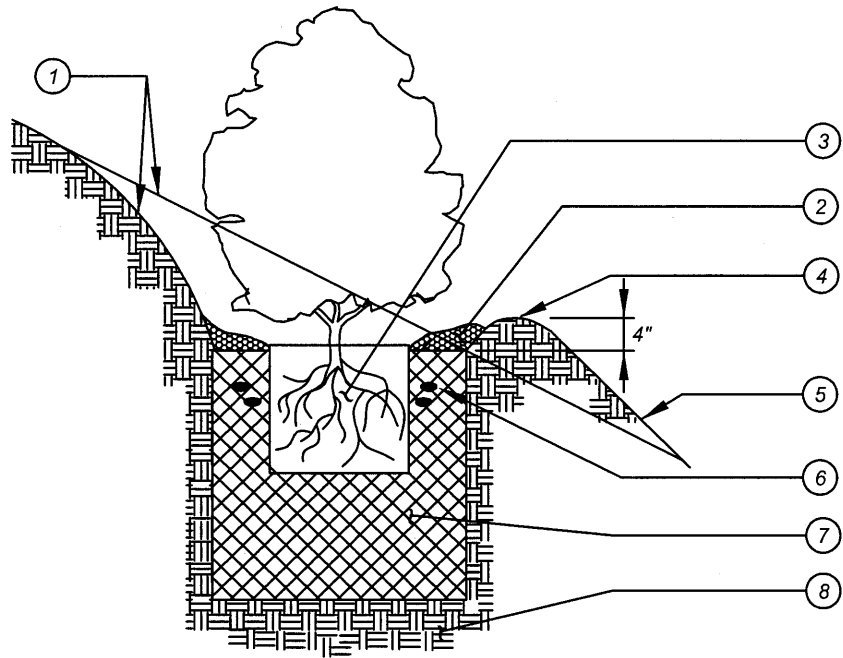
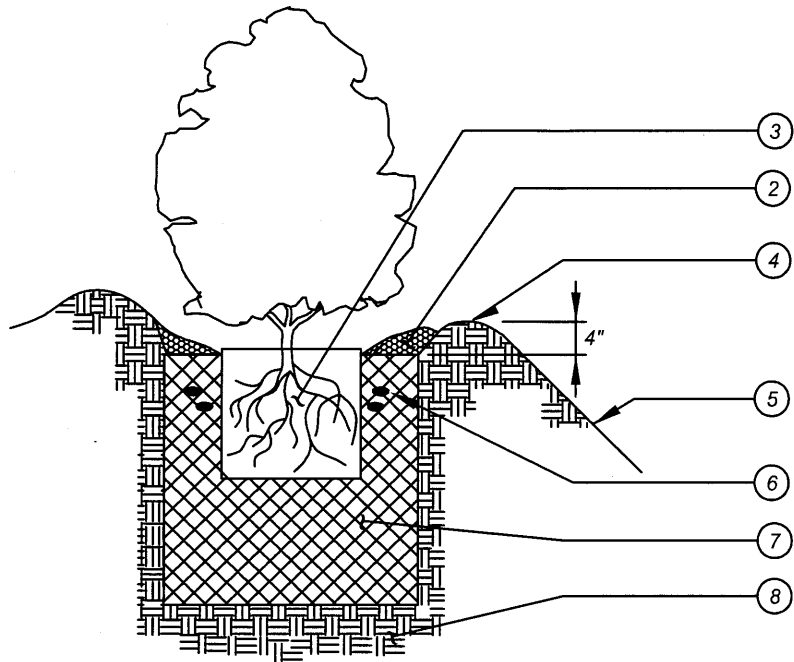



**LEGEND:**

- ① ORIGINAL SLOPE AND CUT SLOPE FOR BASIN
- ② 2" THICK BARK OR DG PER LANDSCAPE SPECIFICATIONS
- ③ ROOTBALL (SET CROWN 1" ABOVE FINISH GRADE TYPICAL)
- ④ COMPACTED WATERING BASIN
- ⑤ FINISH GRADE
- ⑥ ADD TRI-C MYCORRHIZAE PACKS TO EACH PLANT BASIN
- ⑦ COMPACTED BACKFILL MIX (PER NATIVE PLANTING SPECS.) 2x ROOTBALL WIDTH, 2x ROOTBALL DEPTH
- ⑧ UNDISTURBED NATIVE SOIL

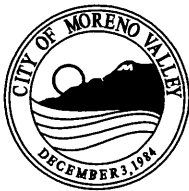
NOT TO SCALE



RECOMMENDED:  
  
 DIVISION MANAGER  
 DATE: 11/27/16

APPROVED:  
  
 PUBLIC WORKS DIRECTOR / CITY ENGINEER  
 DATE: 1/20/17

**CITY OF MORENO VALLEY**

PARKS AND COMMUNITY SERVICES DEPARTMENT

**NATIVE SHRUB PLANTING/  
 ON SLOPE SHRUB PLANTING**

STANDARD PLAN  
**MVLI-502-1**

SHEET 1 OF 1

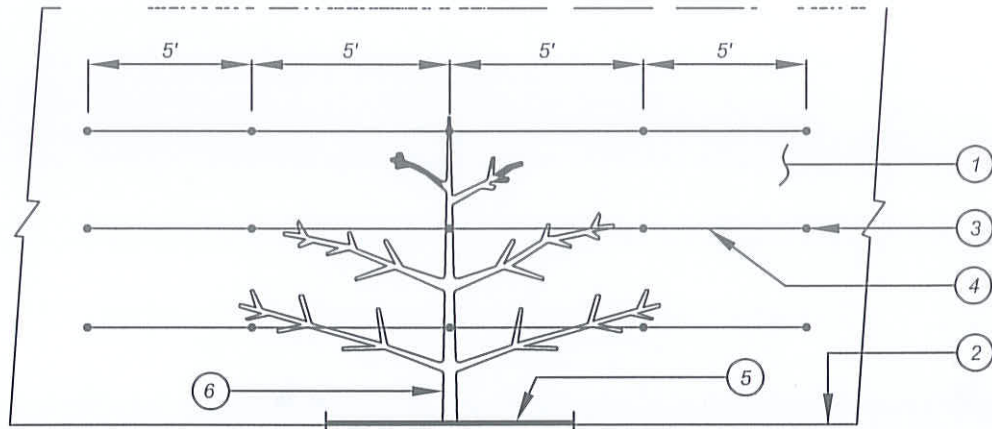

ELEVATION

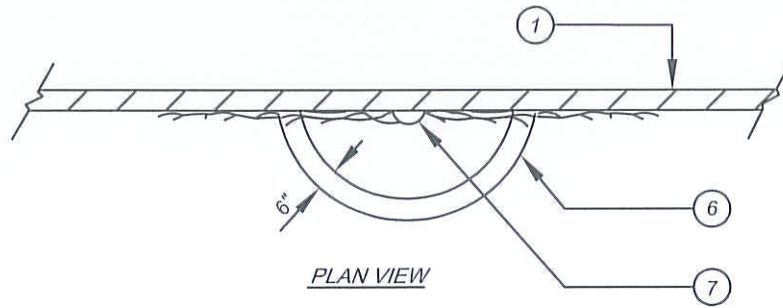

PLAN VIEW

**LEGEND:**

- ① WALL
- ② FINISH GRADE
- ③ EYEBOLTS: 1/2" DIA EYEBOLTS IN LEAD SHIELDS
- ④ 12 GA. GALV. WIRE: SECURE VINE TO WIRE WITH NURSERYMAN'S TAPE
- ⑤ 6" x 8" CONCRETE VINE COLLARS IN TURF AREAS ONLY. INSIDE RADIUS OF COLLAR TO BE TWO TIMES THE DIAMETER OF ROOTBALL MINIMUM
- ⑥ VINE (PER PLAN AS SPECIFIED)

**NOTE:**

- 1.) ANGLE TRUNK OF VINE VINE BACK TO WALL, REMOVE NURSERY STAKE, AND SECURE VINE TO WIRES WITH NURSERYMAN'S TAPE.

NOT TO SCALE

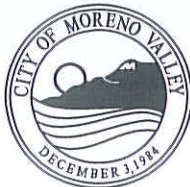

RECOMMENDED:  
 DIVISION MANAGER: *[Signature]* DATE: 1-16-14  
 APPROVED:  
 PUBLIC WORKS DIRECTOR / CITY ENGINEER: *[Signature]* DATE: 1/29/14

**CITY OF MORENO VALLEY**  
 FINANCIAL & MANAGEMENT SERVICES DEPARTMENT - SPECIAL DISTRICTS DIVISION

**VINE DETAIL  
 NON - ADHERING TYPE**

STANDARD PLAN  
**MVLI-503A-0**

SHEET 1 OF 2

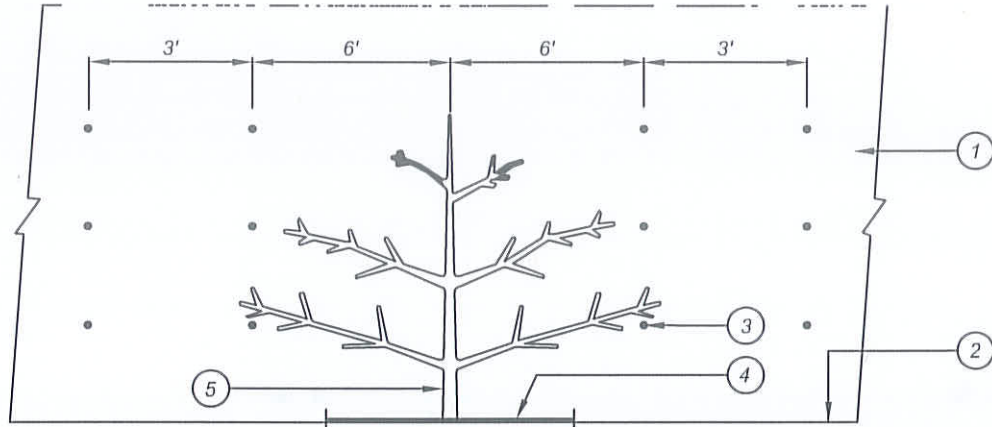

ELEVATION

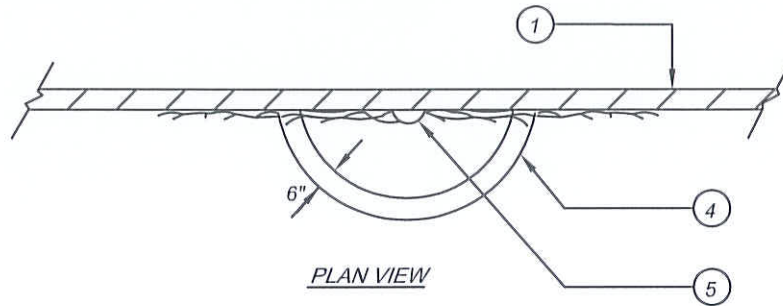

PLAN VIEW

**LEGEND:**

- ① WALL
- ② FINISH GRADE
- ③ ADHESIVE VINE SUPPORTS
- ④ 6" x 8" CONCRETE VINE COLLARS IN TURF AREAS ONLY. INSIDE RADIUS OF COLLAR TO BE TWO TIMES THE DIAMETER OF ROOTBALL MINIMUM (#4 REBAR REQUIRED)
- ⑤ ANGLE BACK TO WALL TRUNK OF VINE, AND REMOVE STAKE WHILE SECURING VINE TO SUPPORTS

NOT TO SCALE

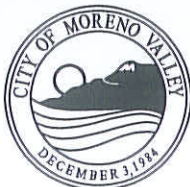

RECOMMENDED:  
 1/21/14  
 DIVISION MANAGER DATE

APPROVED:  
 1/29/14  
 PUBLIC WORKS DIRECTOR / DATE  
 CITY ENGINEER

**CITY OF MORENO VALLEY**

PARKS AND COMMUNITY SERVICES DEPARTMENT

**VINE DETAIL  
 ADHERING TYPE**

STANDARD PLAN  
**MVLI-503B-0**

SHEET 2 OF 2

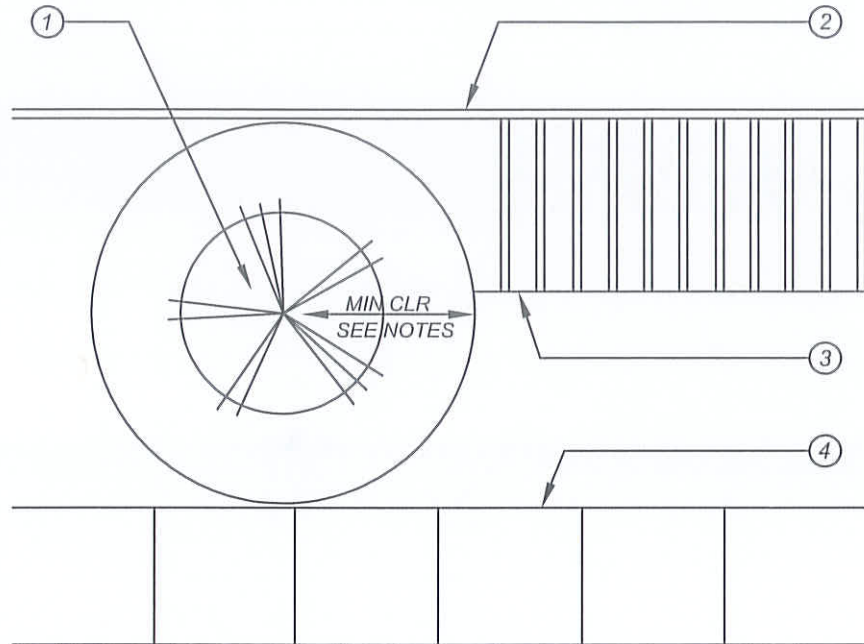

**LEGEND:**

- ① PROPOSED CENTER OF TREE
- ② STRUCTURE /WALL/ETC.
- ③ AWNING/BUILDING OVERHANG
- ④ HARDSCAPING

**NOTES:**

- 1) MINIMUM CLEARANCE: 5'-0" FOR 5 GALLON TO 24" BOX TREES, LARGER TREES PER CITY APPROVAL 10' MINIMUM CLEARANCE FROM STREET LIGHTS - ALL TREES.
- 2) IN CASES WHERE TREE TRUNKS ARE 5'-0" OR LESS FROM WALLS AND HARDSCAPING, INSTALL TREE WITH ROOT BARRIERS (REFER TO STD MVLI-504-0).
- 3) TREE SPACING SHALL BE APPROVED ON PLAN BY THE CITY BEFORE ANY SCHEDULED INSTALLATION.
- 4) STREET TREE PLANS SHALL INCLUDE ALL VERTICAL UTILITIES ON PLANTING PLAN.

NOT TO SCALE

	RECOMMENDED: <div style="display: flex; justify-content: space-between;"> <span><i>cos</i></span> <span>1-16-14</span> </div> <small>DIVISION MANAGER      DATE</small>	<h2 style="margin: 0;">CITY OF MORENO VALLEY</h2> <p style="margin: 0; font-size: small;">FINANCIAL &amp; MANAGEMENT SERVICES DEPARTMENT - SPECIAL DISTRICTS DIVISION</p>	<small>STANDARD PLAN</small> <b>MVLI-504-0</b>	
	APPROVED: <div style="display: flex; justify-content: space-between;"> <span><i>[Signature]</i></span> <span>1/29/14</span> </div> <small>PUBLIC WORKS DIRECTOR /      DATE</small> <small>CITY ENGINEER</small>	<h3 style="margin: 0;">TREE SPACING REQUIREMENTS</h3>		<small>SHEET 1 OF 1</small>
	<small>RECOMMENDED:</small> <small>DIVISION MANAGER      DATE</small> <small>APPROVED:</small> <small>PUBLIC WORKS DIRECTOR /      DATE</small> <small>CITY ENGINEER</small>			<small>STANDARD PLAN</small> <b>MVLI-504-0</b> <small>SHEET 1 OF 1</small>



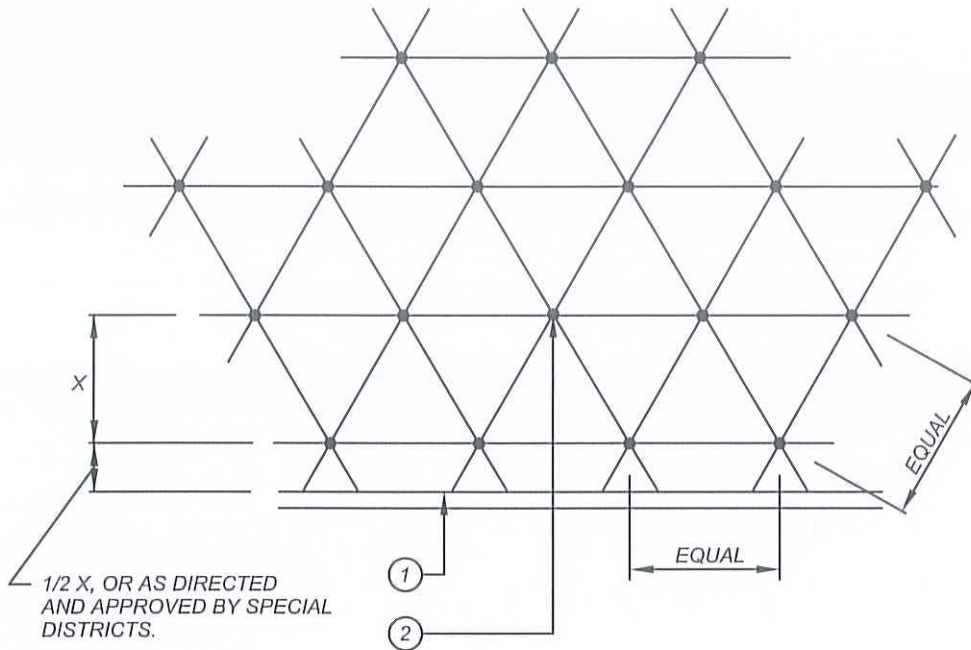



**LEGEND:**

- ① BACK OF CURB OR EDGE OF PAVING
- ② PLANT LOCATION

**NOTES:**

1.) ALL SHRUBS / GROUND COVER TO BE PLANTED AT EQUAL SPACING (TRIANGULAR) UNLESS OTHERWISE INDICATED ON PLANS: SEE LEGEND FOR SPACING REQUIREMENTS.

NOT TO SCALE

	RECOMMENDED: COS 1-16-14 DIVISION MANAGER DATE	<b>CITY OF MORENO VALLEY</b> FINANCIAL & MANAGEMENT SERVICES DEPARTMENT - SPECIAL DISTRICTS DIVISION	
	APPROVED:  1/29/14 PUBLIC WORKS DIRECTOR / DATE CITY ENGINEER	<b>SHRUB / GROUND COVER SPACING</b>	

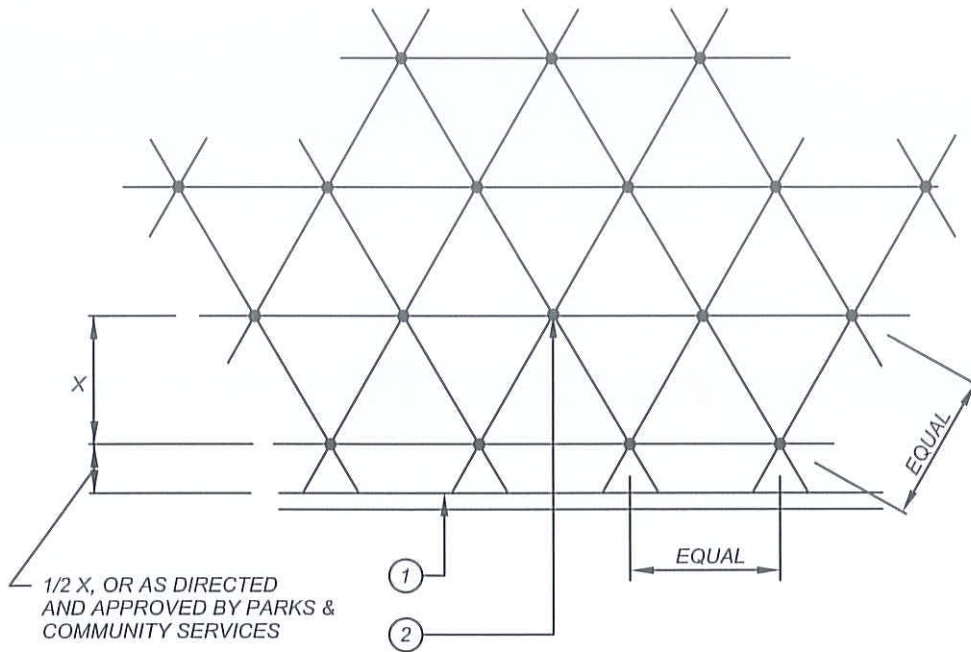

1/2 X, OR AS DIRECTED  
AND APPROVED BY PARKS &  
COMMUNITY SERVICES



**LEGEND:**

- ① BACK OF CURB OR EDGE OF PAVING
- ② PLANT LOCATION

**NOTES:**

1.) ALL SHRUBS / GROUND COVER TO BE PLANTED AT EQUAL SPACING (TRIANGULAR) UNLESS OTHERWISE INDICATED ON PLANS: SEE LEGEND FOR SPACING REQUIREMENTS.

NOT TO SCALE

	RECOMMENDED:  1/21/14 DIVISION MANAGER / DATE	<b>CITY OF MORENO VALLEY</b> PARKS AND COMMUNITY SERVICES DEPARTMENT	
	APPROVED:  1/29/14 PUBLIC WORKS DIRECTOR / DATE CITY ENGINEER	<b>SHRUB / GROUND COVER SPACING</b>	

WIRE SIZE LEGEND	
BOX SIZE	WIRE SIZE
24"	#14
36"	#12
42" & OVER	#10

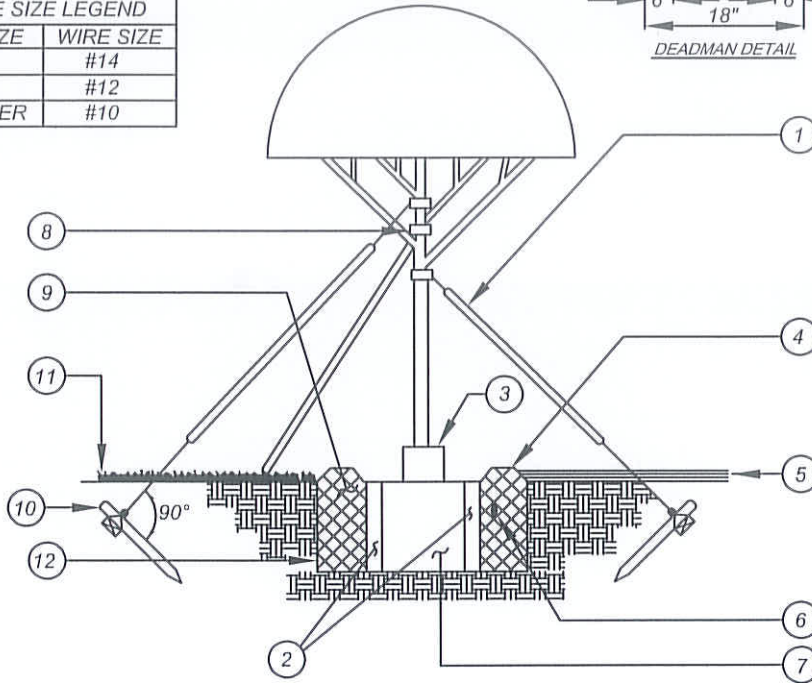
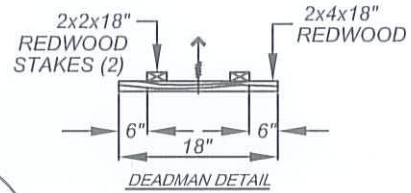

**LEGEND:**

- ① (3) DOUBLE STRAND GALV. 12 GA. WIRE GUYS SPACED EQUALLY AROUND TREE - COVER WITH 3/8" DIA x3" WHITE PVC TUBING
- ② REFER TO STANDARD MVLI-563-0 FOR IRRIGATION METHOD
- ③ USE TRUNK GUARD WHERE TREE IS INSTALLED IN TURF AREAS
- ④ 4" BERM TO FORM DEPRESSED WATERING BASIN
- ⑤ 3" THICK SHREDDED MULCH IN PLANTER
- ⑥ PLANT TABS PER MANUFACTURER'S RECOMMENDATIONS
- ⑦ ROOT BALL
- ⑧ NEW RUBBER HOSE OVER WIRE AT POINT OF CONNECTION
- ⑨ BACKFILL MIX PER SPECIFICATIONS
- ⑩ REDWOOD DEADMAN PER DETAIL THIS SHEET, ALTERNATE METHOD PER CITY EQUIPMENT LIST
- ⑪ TURF
- ⑫ PLANTING PIT TO BE 2 TIMES THE WIDTH OF ROOT BALL & SAME DEPTH AS THE ROOT BALL

**NOTES:**

- 1) INSTALL GUYS HAND TAUT TO PREVENT DEFORMATION OF LIMBS.
- 2) PLACE FERTILIZER TABS IN BOX PRIOR TO PLANTING FOR OBSERVATION.
- 3) ALTERNATE DEADMAN ASSEMBLY.

NOT TO SCALE

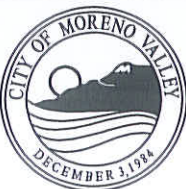

RECOMMENDED:  
 COS 1-16-14  
 DIVISION MANAGER DATE  
 APPROVED:  
 [Signature] 1/29/14  
 PUBLIC WORKS DIRECTOR / DATE /  
 CITY ENGINEER

**CITY OF MORENO VALLEY**  
 FINANCIAL & MANAGEMENT SERVICES DEPARTMENT - SPECIAL DISTRICTS DIVISION

**TREE GUYING DETAIL**  
**36" BOX OR LARGER**

STANDARD PLAN  
**MVLI-510A-0**

SHEET 1 OF 2

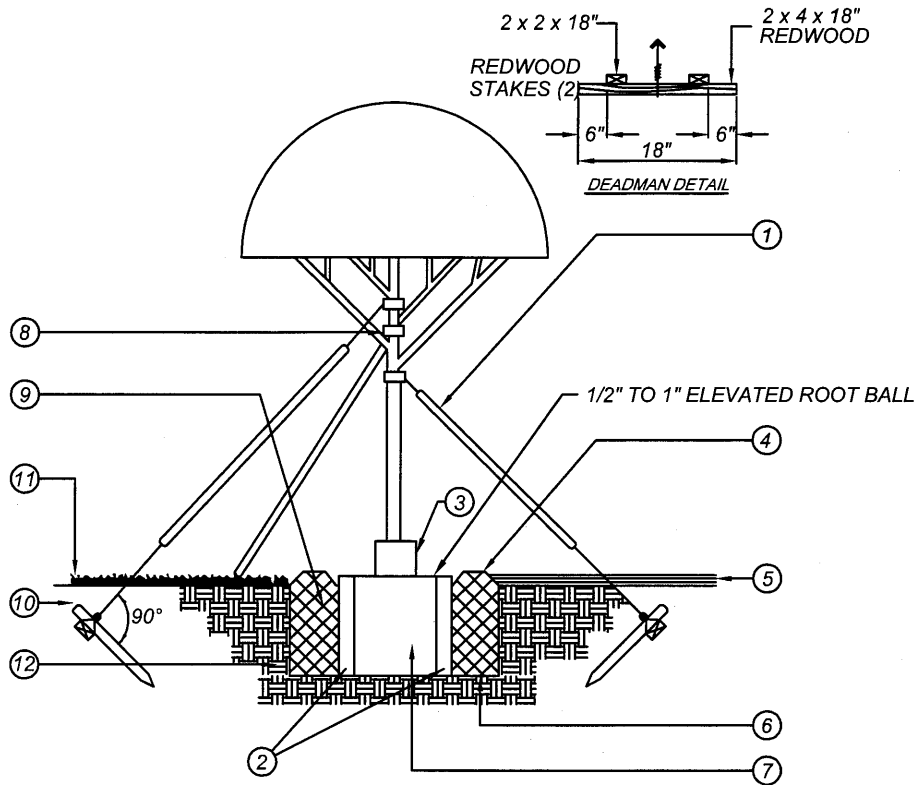

**LEGEND:**

- ① (3) PVC COATED STRANDED 3/8" CABLE GUYS SPACED EQUALLY AROUND TREE - COVER WITH 3/4" DIA WHITE SCH 40 PVC TUBING
- ② REFER TO PARK SPECIFICATIONS FOR IRRIGATION METHOD
- ③ USE TRUNK GUARD WHERE TREE IS INSTALLED IN TURF AREAS
- ④ 4" BERM TO FORM DEPRESSED WATERING BASIN
- ⑤ 3" THICK BARK IN PLANTER
- ⑥ FERTILIZER PER MANUFACTURER'S RECOMMENDATIONS
- ⑦ ROOT BALL
- ⑧ NEW RUBBER HOSE OVER WIRE AT POINT OF CONNECTION
- ⑨ BACKFILL MIX PER SPECIFICATIONS
- ⑩ DEADMAN PER DETAIL THIS SHEET, ALTERNATE METHOD PER CITY EQUIPMENT LIST
- ⑪ TURF
- ⑫ PLANT PIT TO BE 2 TIMES THE WIDTH OF ROOT BALL & SAME DEPTH AS THE ROOT BALL

**NOTES:**

- 1) INSTALL GUYS HAND TAUT TO PREVENT DEFORMATION OF LIMBS.
- 2) PLACE FERTILIZER PACKETS IN BOX PRIOR TO PLANTING FOR OBSERVATION.
- 3) ALTERNATE DEADMAN ASSEMBLY.

NOT TO SCALE



RECOMMENDED:  
*[Signature]* 12/22/16  
 DIVISION MANAGER DATE  
 APPROVED:  
*[Signature]* 12/20/16  
 PUBLIC WORKS DIRECTOR / DATE  
 CITY ENGINEER

**CITY OF MORENO VALLEY**

PARKS AND COMMUNITY SERVICES DEPARTMENT

**TREE GUYING DETAIL  
 36" BOX OR LARGER**

STANDARD PLAN  
**MVLI-510B-1**

SHEET 2 OF 2



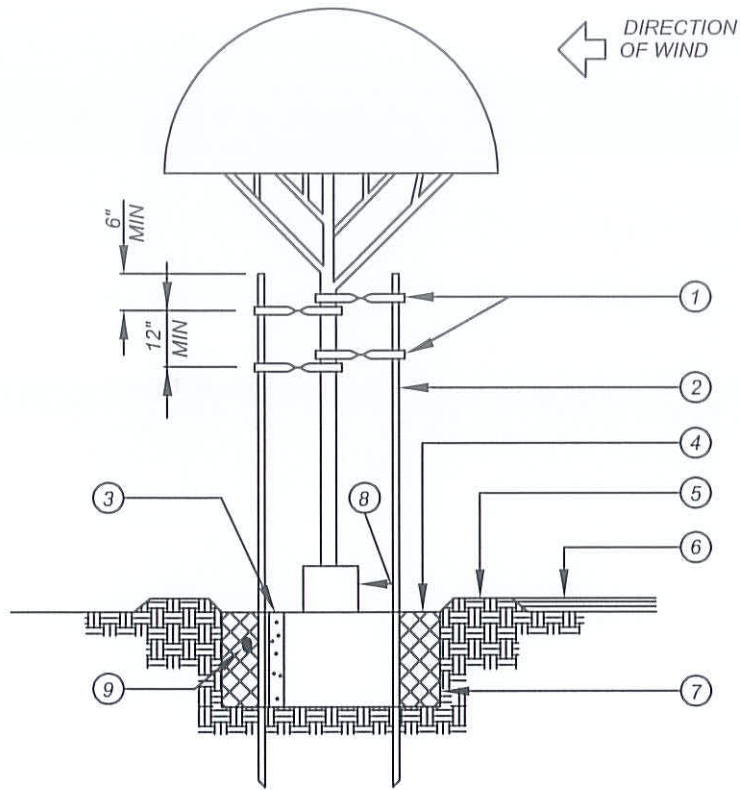



**LEGEND:**

- ① TREE TIES 4 REQUIRED
- ② 2" LODGEPOLE PINE STAKE
- ③ REFER TO STANDARD MVLI-563-0 FOR IRRIGATION METHOD
- ④ BACKFILL MIX PER SPECIFICATIONS
- ⑤ 4" BERM FOR TEMPORARY WATERING UNTIL SEEDING
- ⑥ 3" THICK SHREDDED MULCH - WHERE APPLICABLE IN PLANTER BEDS
- ⑦ PLANTING PIT: 2 TIMES WIDTH OF ROOT BALL & SAME DEPTH AS ROOT BALL
- ⑧ TRUNK GUARD IN TURF AREAS
- ⑨ PLACE PLANT TABS PER MANUFACTURERS RECOMMENDATION

**NOTES:**

- 1) INSTALL STAKES 12" MINIMUM FROM TREE TRUNK AND/OR OUTSIDE OF ROOTBALL.

NOT TO SCALE

	RECOMMENDED: <i>COS</i> <i>1-16-14</i> <small>DIVISION MANAGER     DATE</small>	<b>CITY OF MORENO VALLEY</b> FINANCIAL & MANAGEMENT SERVICES DEPARTMENT - SPECIAL DISTRICTS DIVISION	STANDARD PLAN <b>MVLI-511A-0</b>
	APPROVED:  <i>1/29/14</i> <small>PUBLIC WORKS DIRECTOR / DATE</small> <small>CITY ENGINEER</small>	<b>TYPICAL DOUBLE STAKE TREE</b> <b>(15 GAL. - 24" BOX)</b>	SHEET 1 OF 5

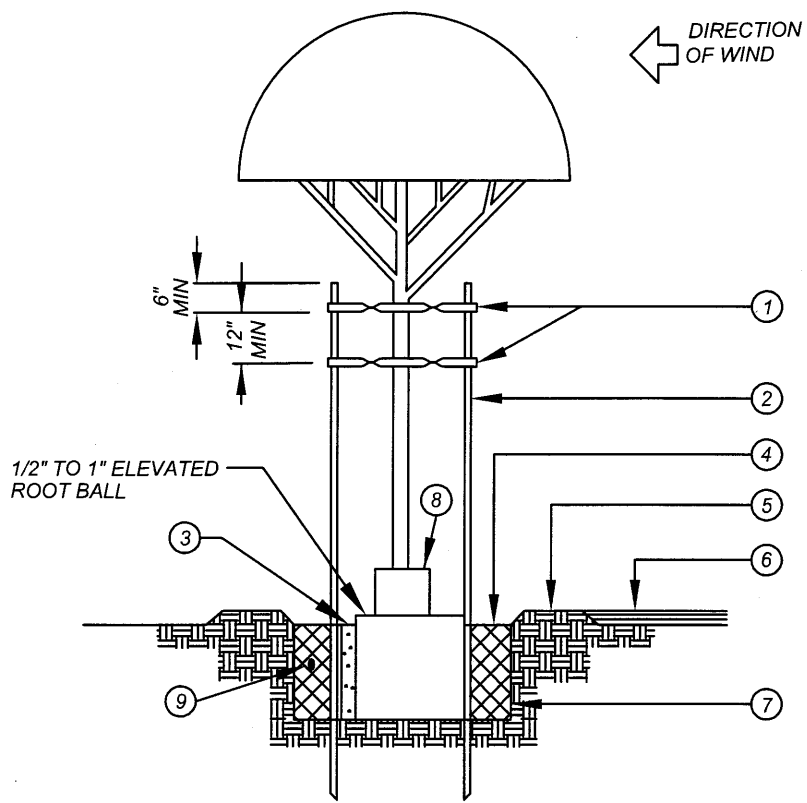

**LEGEND:**

- ① V.I.T. PLASTIC COATED METAL BRACE 2 REQUIRED
- ② 2" LODGEPOLE PINE STAKE
- ③ RAINBIRD ROOT WATERING SYSTEM (RWS) IRRIGATION (EXCEPT TURF AREAS)
- ④ BACKFILL MIX PER SPECIFICATIONS
- ⑤ 4" BERM FOR TEMPORARY WATERING UNTIL SEEDING/SODDING
- ⑥ 3" THICK BARK - WHERE APPLICABLE
- ⑦ PLANT PIT: 2 TIMES WIDTH OF ROOT BALL & SAME DEPTH AS ROOT BALL
- ⑧ TRUNK GUARD IN TURF AREAS
- ⑨ PLACE FERTILIZER PACKETS PER MANUFACTURER'S RECOMMENDATION

**NOTES:**

- 1) INSTALL STAKES 12" MINIMUM FROM TREE TRUNK AND/OR OUTSIDE ROOTBALL.

NOT TO SCALE

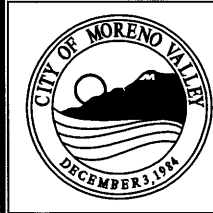

RECOMMENDED:  
 DIVISION MANAGER DATE 1/20/16  
 APPROVED:  
 PUBLIC WORKS DIRECTOR / DATE 1/20/16  
 CITY ENGINEER

**CITY OF MORENO VALLEY**  
 PARKS AND COMMUNITY SERVICES DEPARTMENT

**TYPICAL DOUBLE STAKE TREE**

STANDARD PLAN  
**MVLI-511B-1**  
 SHEET 2 OF 5

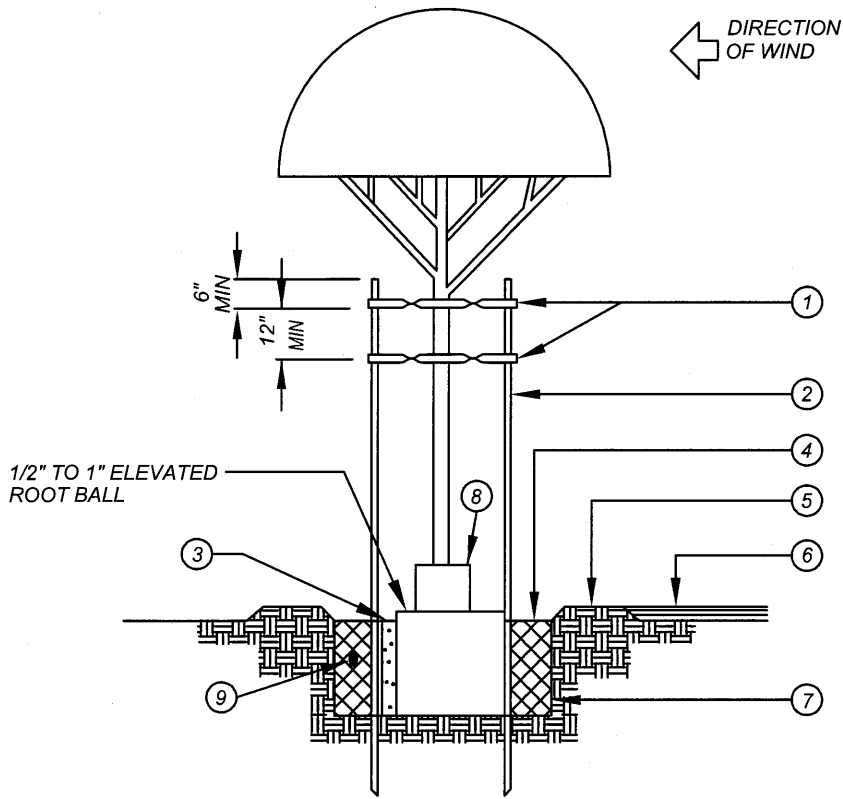



**LEGEND:**

- ① V.I.T. PLASTIC COATED METAL BRACE 2 REQUIRED BOLT TO PIPE
- ② 2" SCHEDULE 40 GALVANIZED PIPE. DRILL PIPE TO INSTALL TWIST BRACE
- ③ RAINBIRD ROOT WATERING SYSTEM (RWS) IRRIGATION, MINIMUM 2 (EXCEPT TURF AREAS)
- ④ BACKFILL MIX PER SPECIFICATIONS
- ⑤ 4" BERM FOR TEMPORARY WATERING UNTIL SEEDING/SODDING
- ⑥ 3" THICK BARK - WHERE APPLICABLE
- ⑦ PLANT PIT: 2 TIMES WIDTH OF ROOT BALL & SAME DEPTH AS ROOT BALL
- ⑧ TRUNK GUARD IN TURF AREAS
- ⑨ PLACE FERTILIZER PACKETS PER MANUFACTURER'S RECOMMENDATION

**NOTES:**

- 1) INSTALL STAKES 18" MINIMUM FROM TREE TRUNK AND/OR OUTSIDE ROOTBALL.

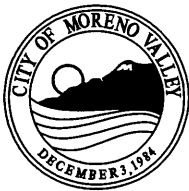
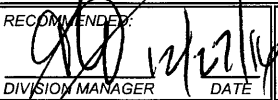
NOT TO SCALE

	RECOMMENDED:  DIVISION MANAGER      DATE	<b>CITY OF MORENO VALLEY</b> PARKS AND COMMUNITY SERVICES DEPARTMENT	
	APPROVED:  PUBLIC WORKS DIRECTOR / DATE CITY ENGINEER	<b>STEEL DOUBLE STAKE TREE</b>	

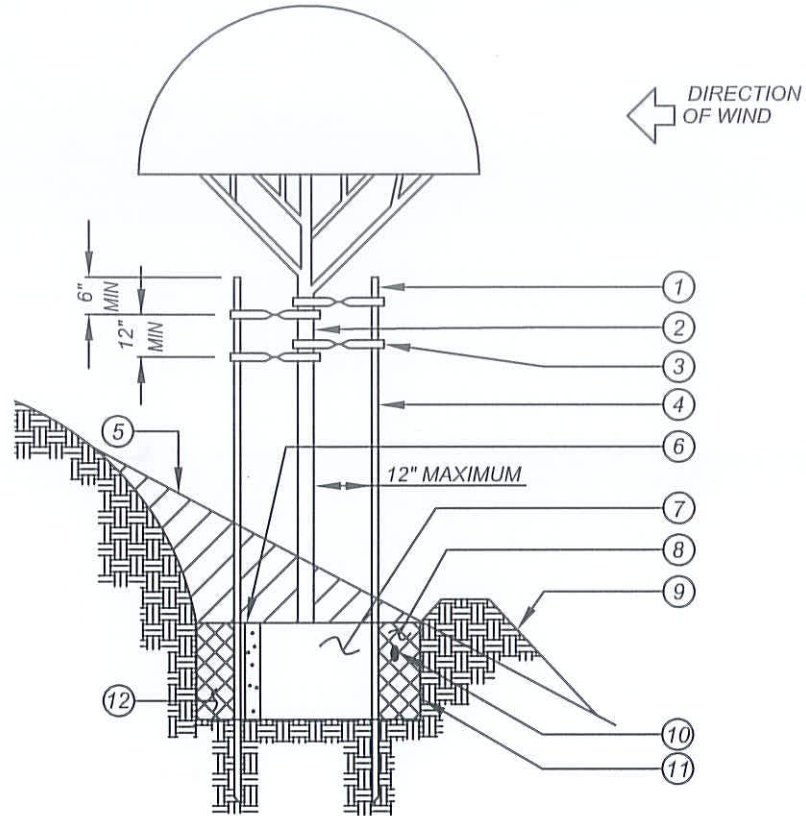

**LEGEND:**

- ① TOP OF STAKES
- ② MAIN TRUNK
- ③ TREE TIES (4 REQUIRED) 12" APART MIN. NAILED TO STAKES
- ④ APPROVED 10' TREE STAKES (2) PER SPECIFICATIONS
- ⑤ ORIGINAL GRADE
- ⑥ REFER TO STANDARD MVLI-563-0 FOR IRRIGATION METHOD
- ⑦ CONTAINER ROOT BALL
- ⑧ BACKFILL MIX PER SPECIFICATIONS
- ⑨ 4" BERM TIGHTLY COMPACTED IN PLACE TO FORM WATERING BASIN
- ⑩ PLANTING TABS PER MANUFACTURERS RECOMMENDATIONS
- ⑪ PLANTING PIT TO BE 2 TIMES WIDTH OF ROOT BALL & SAME DEPTH AS THE ROOT BALL
- ⑫ NATIVE SOIL BACKFILL (COMPACTED)

**NOTES:**

1) INSTALL STAKES 12" MINIMUM FROM TREE TRUNK AND/OR OUTSIDE OF ROOTBALL.

NOT TO SCALE



RECOMMENDED:  
 COS 1-16-14  
 DIVISION MANAGER DATE  
 APPROVED:  
 [Signature] 1/29/14  
 PUBLIC WORKS DIRECTOR DATE  
 CITY ENGINEER

**CITY OF MORENO VALLEY**  
 FINANCIAL & MANAGEMENT SERVICES DEPARTMENT - SPECIAL DISTRICTS DIVISION

**DOUBLE STAKE TREE ON SLOPE MVLI-511D-0**

STANDARD PLAN

SHEET 4 OF 5



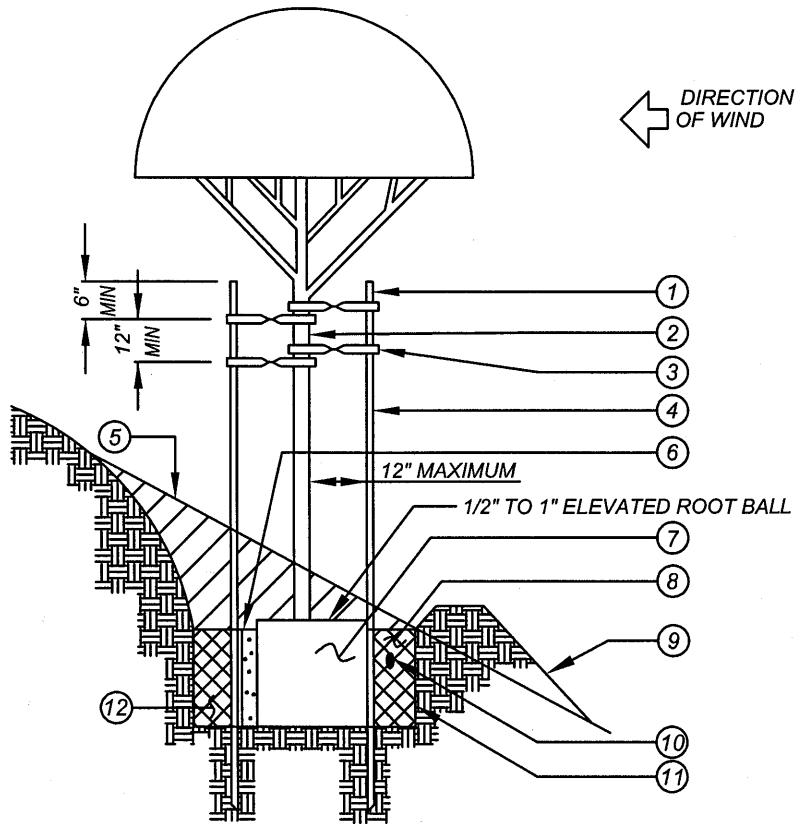



**LEGEND:**

- ① TOP OF STAKES
- ② MAIN TRUNK
- ③ TREE TIES (4 REQUIRED) 12" APART MIN NAILED TO STAKES
- ④ APPROVED 10' TREE STAKES (2) PER SPECIFICATIONS
- ⑤ ORIGINAL GRADE
- ⑥ REFER TO STANDARD MVLI-563 FOR IRRIGATION METHOD
- ⑦ CONTAINER ROOT BALL
- ⑧ BACKFILL MIX PER SPECIFICATIONS
- ⑨ 4" BERM TIGHTLY COMPACTED IN PLACE TO FORM WATERING BASIN
- ⑩ FERTILIZER PACKETS PER MANUFACTURERS RECOMMENDATIONS
- ⑪ PLANTING PIT TO BE 2 TIMES WIDTH OF ROOT BALL & SAME DEPTH AS THE ROOT BALL
- ⑫ BACKFILL PER SPECIFICATIONS

**NOTES:**

1) INSTALL STAKES 12" MINIMUM FROM TREE TRUNK AND/OR OUTSIDE OF ROOT BALL.

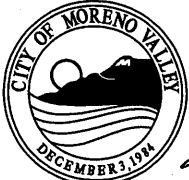
NOT TO SCALE

	RECOMMENDED:  1/24/17 DIVISION MANAGER      DATE	<h2 style="margin: 0;">CITY OF MORENO VALLEY</h2> <p style="margin: 0;">PARKS AND COMMUNITY SERVICES DEPARTMENT</p>	STANDARD PLAN
	APPROVED:  1/20/17 PUBLIC WORKS DIRECTOR / DATE CITY ENGINEER	<h3 style="margin: 0;">DOUBLE STAKE TREE ON SLOPE</h3>	

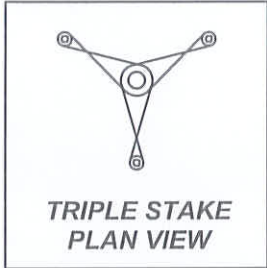
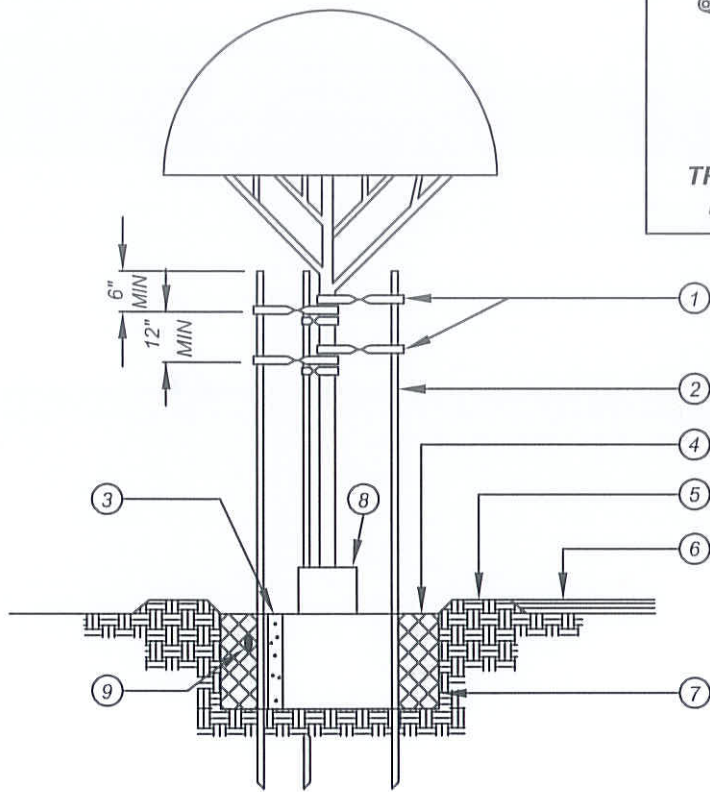



**LEGEND:**

- ① TREE TIES 6 REQUIRED
- ② 2" LODGEPOLE PINE STAKES (3) PER SPECIFICATIONS
- ③ REFER TO STANDARD MVLI-563-0 FOR IRRIGATION METHOD
- ④ BACKFILL MIX PER SPECIFICATIONS
- ⑤ 4" BERM FOR TEMPORARY WATERING UNTIL SEEDING
- ⑥ 3" THICK SHREDDED MULCH - WHERE APPLICABLE IN PLANTER BEDS
- ⑦ PLANTING PIT: 2 TIMES WIDTH OF ROOT BALL & SAME DEPTH AS ROOT BALL
- ⑧ TRUNK GUARD IN TURF AREAS
- ⑨ PLACE PLANT TABS PER MANUFACTURER'S RECOMMENDATION

**NOTES:**

- 1) INSTALL STAKES 12" MINIMUM FROM TREE TRUNK AND/OR OUTSIDE OF ROOTBALL.

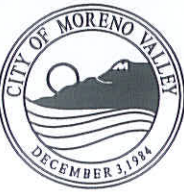
NOT TO SCALE

	RECOMMENDED:  DIVISION MANAGER      DATE	<b>CITY OF MORENO VALLEY</b> FINANCIAL & MANAGEMENT SERVICES DEPARTMENT - SPECIAL DISTRICTS DIVISION	
	APPROVED:  PUBLIC WORKS DIRECTOR / DATE CITY ENGINEER	<b>TRIPLE STAKE TREE</b>	

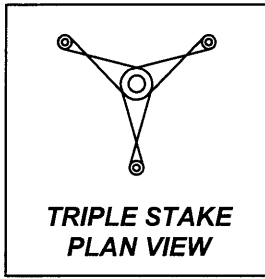
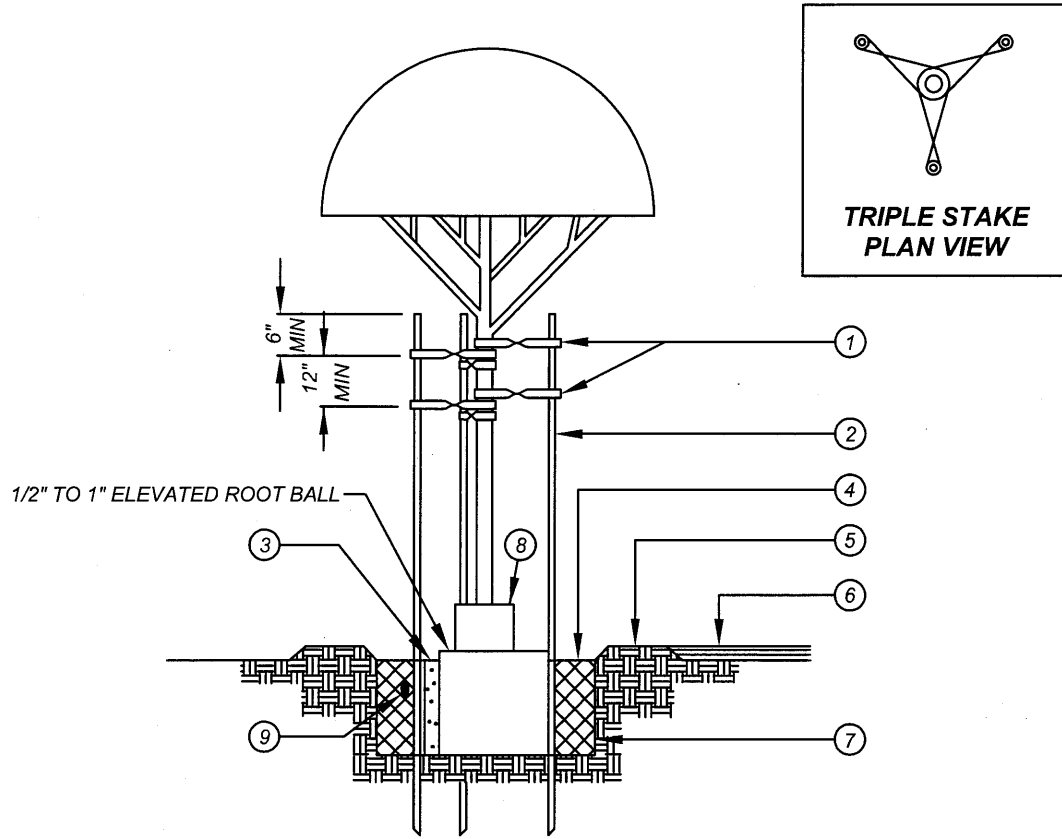



**LEGEND:**

- ① TREE TIES 6 REQUIRED
- ② 3" LODGEPOLE PINE STAKES (3) PER SPECIFICATIONS
- ③ REFER TO STANDARD MVLI-563 FOR IRRIGATION METHOD
- ④ BACKFILL MIX PER SPECIFICATIONS
- ⑤ 4" BERM FOR TEMPORARY WATERING UNTIL SEEDING/SODDING
- ⑥ 3" THICK SHREDDED BARK - WHERE APPLICABLE IN PLANTER BEDS
- ⑦ PLANTING PIT: 2 TIMES WIDTH OF ROOT BALL & SAME DEPTH AS ROOT BALL
- ⑧ TRUNK GUARD IN TURF AREAS
- ⑨ PLACE FERTILIZER PACKETS PER MANUFACTURER'S RECOMMENDATIONS

**NOTES:**

- 1) INSTALL STAKES 12" MINIMUM FROM TREE TRUNK AND/OR OUTSIDE OF ROOT BALL.

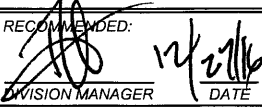
NOT TO SCALE

	RECOMMENDED:  DIVISION MANAGER      DATE	<h2 style="margin: 0;">CITY OF MORENO VALLEY</h2> <p style="margin: 0;">PARKS AND COMMUNITY SERVICES DEPARTMENT</p>	
	APPROVED:  PUBLIC WORKS DIRECTOR / DATE CITY ENGINEER	<h3 style="margin: 0;">TRIPLE STAKE TREE</h3>	STANDARD PLAN <h3 style="margin: 0;">MVLI-512B-1</h3>

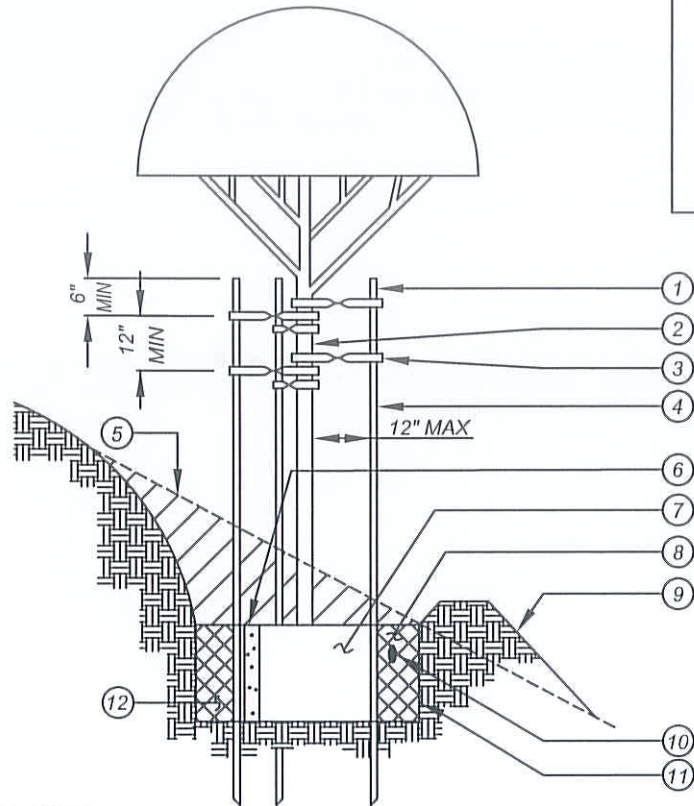
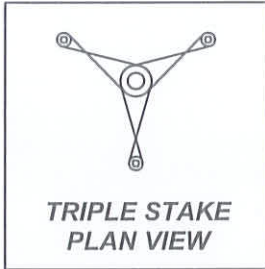

**LEGEND:**

- ① TOP OF STAKES
- ② MAIN TRUNK
- ③ TREE TIES (6 REQUIRED) 12" APART MIN. NAILED TO STAKES
- ④ APPROVED 10' TREE STAKES (3) PER SPECIFICATIONS
- ⑤ ORIGINAL GRADE
- ⑥ REFER TO STANDARD MVLI-563-0 FOR IRRIGATION METHOD
- ⑦ CONTAINER ROOT BALL
- ⑧ BACKFILL MIX PER SPECIFICATIONS
- ⑨ 4" BERM TIGHTLY COMPACTED IN PLACE TO FORM WATERING BASIN
- ⑩ PLANTING TABS PER MANUFACTURERS RECOMMENDATIONS
- ⑪ PLANTING PIT TO BE 2 TIMES WIDTH OF ROOT BALL & SAME DEPTH AS THE ROOT BALL
- ⑫ NATIVE SOIL BACKFILL (COMPACTED)

**NOTES:**

1) INSTALL STAKES 12" MINIMUM FROM TREE TRUNK AND/OR OUTSIDE OF ROOTBALL.

NOT TO SCALE

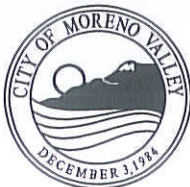

RECOMMENDED:  
*COS* 1-16-14  
 DIVISION MANAGER DATE  
 APPROVED:  
*[Signature]* 1/29/14  
 PUBLIC WORKS DIRECTOR / DATE  
 CITY ENGINEER

**CITY OF MORENO VALLEY**  
 FINANCIAL & MANAGEMENT SERVICES DEPARTMENT - SPECIAL DISTRICTS DIVISION

**TRIPLE STAKE TREE ON SLOPE**

STANDARD PLAN  
**MVLI-512C-0**

SHEET 3 OF 4



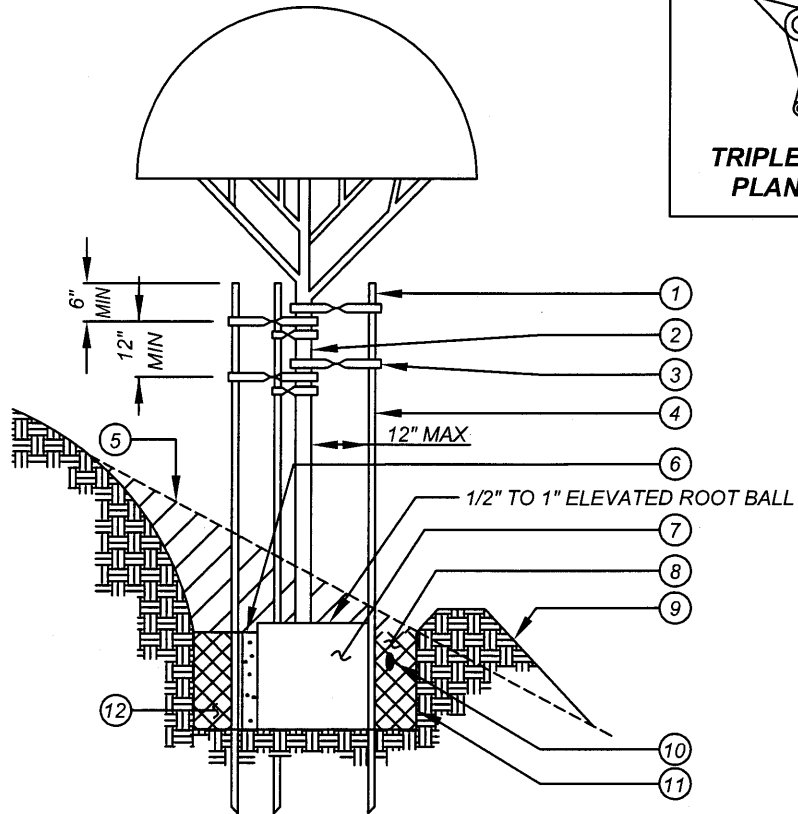
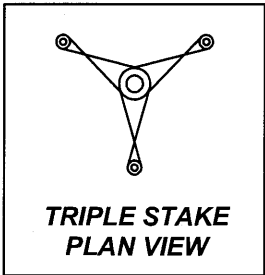

**LEGEND:**



- ① TOP OF STAKES
- ② MAIN TRUNK
- ③ TREE TIES (6 REQUIRED) 12" APART MIN NAILED TO STAKES
- ④ APPROVED 10' TREE STAKES (3) PER SPECIFICATIONS
- ⑤ ORIGINAL GRADE
- ⑥ REFER TO STANDARD MVLI-563 FOR IRRIGATION METHOD
- ⑦ CONTAINER ROOT BALL
- ⑧ BACKFILL MIX PER SPECIFICATIONS
- ⑨ 4" BERM TIGHTLY COMPACTED IN PLACE TO FORM WATERING BASIN
- ⑩ FERTILIZER PACKETS PER MANUFACTURERS RECOMMENDATIONS
- ⑪ PLANTING PIT TO BE 2 TIMES WIDTH OF ROOT BALL & SAME DEPTH AS THE ROOT BALL
- ⑫ BACKFILL PER SPECIFICATIONS

**NOTES:**

1) INSTALL STAKES 12" MINIMUM FROM TREE TRUNK AND/OR OUTSIDE OF ROOT BALL.

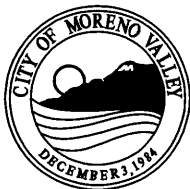
NOT TO SCALE

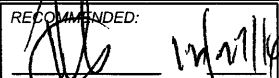

RECOMMENDED:  
  
 DIVISION MANAGER DATE  
 APPROVED:  
  
 PUBLIC WORKS DIRECTOR / DATE  
 CITY ENGINEER

**CITY OF MORENO VALLEY**

PARKS AND COMMUNITY SERVICES DEPARTMENT

**TRIPLE STAKE TREE ON SLOPE**

STANDARD PLAN  
**MVLI-512D-1**  
 SHEET 4 OF 4

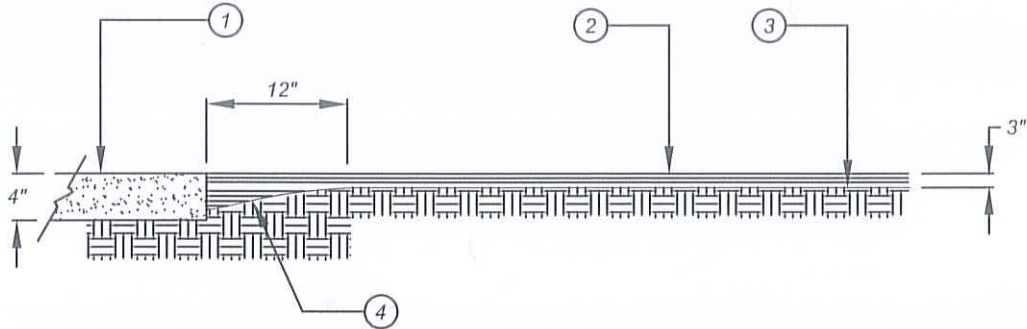



**LEGEND:**

- ① HARDCAPING/HEADERBOARD
- ② SHREDDED MULCH (PER PLAN AS SPECIFIED)
- ③ FINISH GRADE
- ④ SHOVEL CUT EDGE (ENSURE THAT BOTTOM EDGE OF SIDEWALK AND/OR HARDCAPE IS NOT EXPOSED)

**NOTES:**

- 1) MULCH UNDER TREES AND SHRUBS, AND BLEND EDGES AT GROUND COVER AREAS.
- 2) NOT TO BE USED WITH FLATTED PLANTS UNDER 16" ON CENTER.
- 3) PULL MULCH AWAY FROM ROOT CROWNS OF TREES & SHRUBS - AMOUNT PER THE DISCRETION OF SPECIAL DISTRICTS.

NOT TO SCALE

	RECOMMENDED:  1-10-14 DIVISION MANAGER / DATE	<b>CITY OF MORENO VALLEY</b> FINANCIAL & MANAGEMENT SERVICES DEPARTMENT - SPECIAL DISTRICTS DIVISION	
	APPROVED:  1/29/14 PUBLIC WORKS DIRECTOR / DATE CITY ENGINEER	<b>MULCH INSTALLATION</b>	

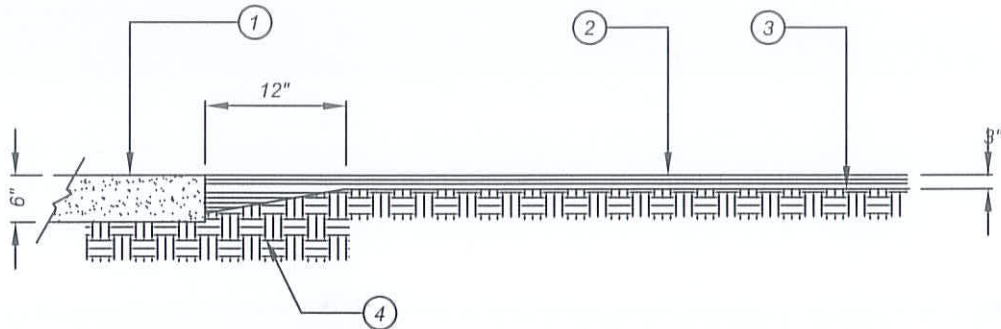

**LEGEND:**

- ① MOW CURB/HARDSCAPE/HEADER
- ② BARK / DG MULCH PER PARKS SPECIFICATIONS
- ③ FINISH GRADE
- ④ SHOVEL CUT EDGE

**NOTES:**

- 1) MULCH UNDER TREES AND SHRUBS, AND BLEND EDGES AT GROUND COVER AREAS.
- 2) NOT TO BE USED WITH ANNUAL FLOWERS.
- 3) PULL MULCH AWAY FROM ROOT CROWNS OF TREES & SHRUBS.
- 4) DETAIL CAN BE USED FOR PALM SPRINGS GOLD SAND OR DECOMPOSED GRANITE IN PLANTERS.

NOT TO SCALE

	RECOMMENDED: <i>JH</i> 1/21/14 DIVISION MANAGER DATE	<b>CITY OF MORENO VALLEY</b> PARKS AND COMMUNITY SERVICES DEPARTMENT	
	APPROVED: <i>[Signature]</i> 1/29/14 PUBLIC WORKS DIRECTOR / DATE CITY ENGINEER	<b>BARK INSTALLATION</b>	

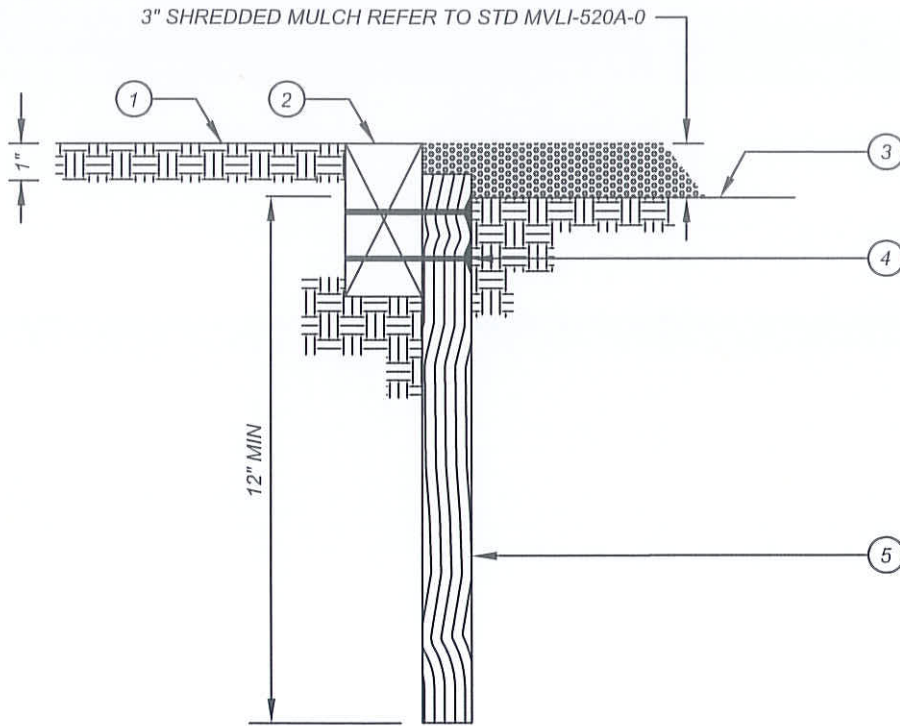

**LEGEND:**

- ① FINISH GRADE
- ② 2 x 4 ROUGH SAWN REDWOOD HEADER BOARD (NOTCH) OR INSTALL AT GRADE LEVEL AT SWALE CROSSING
- ③ FINISH GRADE IN PLANT BED
- ④ 8d GALVANIZED NAILS (2)
- ⑤ 2" x 2" x 24" REDWOOD STAKES AT 3' OC AND AT ALL SPLICES

**NOTES:**

- 1.) 24" LAP ALL SPLICES. USE ROUGH SAWN LUMBER UNLESS OTHERWISE APPROVED BY THE CITY
  - 2.) CURVED SECTIONS OF HEADER SHALL BE CONSTRUCTED OF THREE 3/8" x 4" LAMINATED REDWOOD BENDER BOARD
- NOT TO SCALE

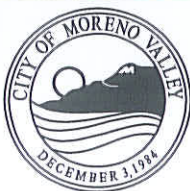

RECOMMENDED:  
*COS* 1-7-14  
 DIVISION MANAGER DATE

APPROVED:  
*[Signature]* 1/29/14  
 PUBLIC WORKS DIRECTOR / DATE  
 CITY ENGINEER

**CITY OF MORENO VALLEY**  
 FINANCIAL & MANAGEMENT SERVICES DEPARTMENT - SPECIAL DISTRICTS DIVISION

**2" x 4" REDWOOD HEADER**

STANDARD PLAN  
**MVLI-521-0**  
 SHEET 1 OF 1



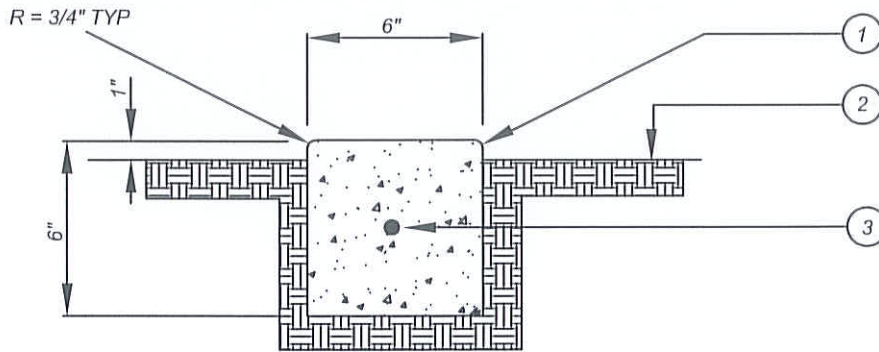



**LEGEND:**

- ① CONCRETE MOW CURB - 3/4" RADIUS EXPOSED EDGES. MEDIUM BROOM FINISH OR PER PLAN (INSTALL GRADE LEVEL AT SWALE CROSSING)
- ② FINISH GRADE
- ③ #4 REBAR CONTINUOUS

**NOTE:**

- 1.) PROVIDE DEEP SCORE JOINTS AT 8' OC AND 3/8" RUBBER EXPANSION JOINTS AT 24' OC.
- 2.) CONCRETE SHALL BE 560-C-3250.

NOT TO SCALE

	RECOMMENDED:  1.16.14 DIVISION MANAGER / DATE	<b>CITY OF MORENO VALLEY</b> FINANCIAL & MANAGEMENT SERVICES DEPARTMENT - SPECIAL DISTRICTS DIVISION	
	APPROVED:  1/29/14 PUBLIC WORKS DIRECTOR / CITY ENGINEER / DATE	<b>6" WIDE CONCRETE MOW CURB</b>	

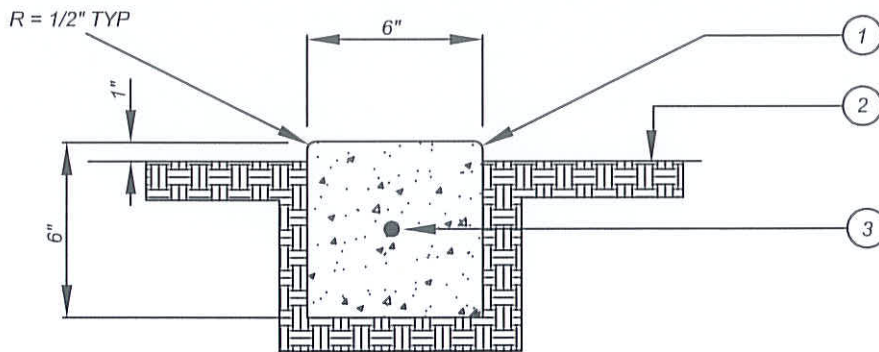

**LEGEND:**

- ① CONCRETE MOW CURB - 1/2" RADIUS EXPOSED EDGES. MEDIUM BROOM FINISH OR PER PLAN (INSTALL GRADE LEVEL AT SWALE CROSSING)
- ② FINISH GRADE
- ③ #4 REBAR CONTINUOUS

**NOTE:**

- 1.) PROVIDE 1/2" DEEP SCORE JOINTS AT 8' OC AND 3/8" RUBBER EXPANSION JOINTS AT 50' OC.
- 2.) CONCRETE SHALL BE 560-C-3250 OR 660-C-4000 FOR PUMP MIX.
- 3.) COLOR PER PLAN OR SPECIFICATIONS.
- 4.) CONCRETE FINISH AS REQUIRED.

NOT TO SCALE

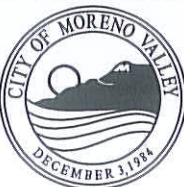

RECOMMENDED:  
 [Signature] 1/20/14  
 DIVISION MANAGER DATE  
 APPROVED:  
 [Signature] 1/29/14  
 PUBLIC WORKS DIRECTOR DATE  
 CITY ENGINEER

**CITY OF MORENO VALLEY**

PARKS AND COMMUNITY SERVICES DEPARTMENT

**6" WIDE CONCRETE MOW CURB**

STANDARD PLAN  
**MVLI-522B-0**

SHEET 2 OF 3

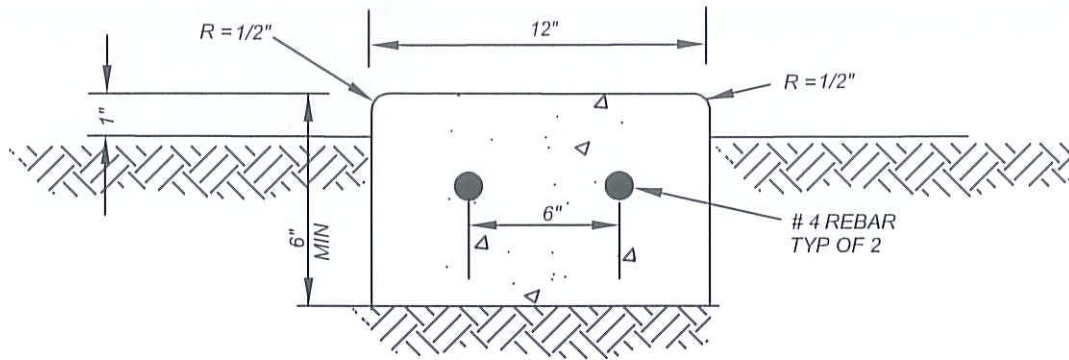

**NOTES:**

- 1.) CONCRETE MOW STRIP REQUIRED NEXT TO LANDSCAPED AREAS & UNDER FENCES FOR PARK SITES.
- 2.) CONCRETE TYPE IS 560-C-3250 MINIMUM (OR 660-C-4000 FOR PUMP MIX). NO FLY ASH.
- 3.) CONCRETE COLOR PER PLAN OR SPECIFICATIONS.
- 4.) FINISH AS REQUIRED.

NOT TO SCALE

	RECOMMENDED:  DIVISION MANAGER      1/21/14 DATE	<b>CITY OF MORENO VALLEY</b> PARKS AND COMMUNITY SERVICES DEPARTMENT	STANDARD PLAN <b>MVLI-522C-0</b>
	APPROVED:  PUBLIC WORKS DIRECTOR / DATE CITY ENGINEER      1/29/14	<b>12" WIDE CONCRETE MOW CURB</b>	SHEET 3 OF 3

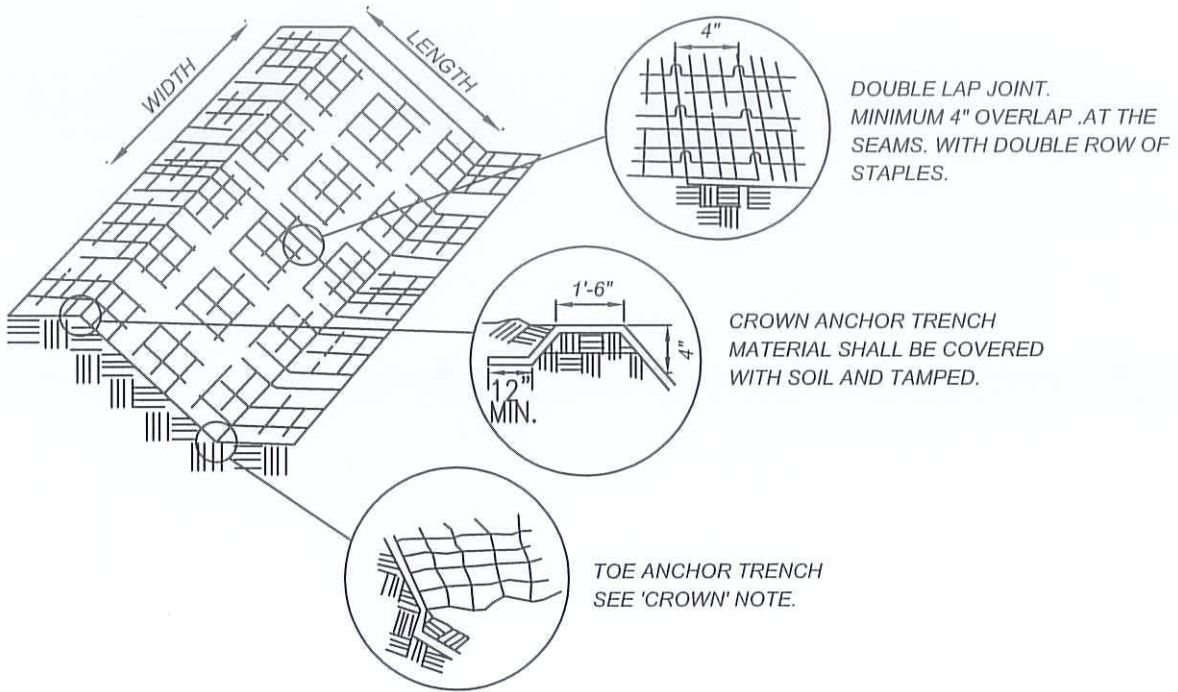

**NOTES:**

- 1.) GROUND COVER MAY BE PLANTED THROUGH THE FABRIC.
- 2.) THE FABRIC SHALL BE INSTALLED ON GROUND A MINIMUM OF 48 HOURS PRIOR TO PLANTING TO ALLOW FABRIC TO SETTLE.
- 3.) HOLES FOR PLANTING SHALL BE MADE WITH SHARP KNIVES OR SHEARS.
- 4.) FABRIC IS TO BE FASTENED USING No 11 GAUGE WIRE. 'U' SHAPED WITH 1" CROWN AND LESS 12" IN LENGTH OR PREFABRICATED STAPLES.
- 5.) INSTALLATION PER MANUFACTURES SPECIFICATIONS.

NOT TO SCALE

	RECOMMENDED:  DIVISION MANAGER      DATE 1-16-14	<b>CITY OF MORENO VALLEY</b> FINANCIAL & MANAGEMENT SERVICES DEPARTMENT - SPECIAL DISTRICTS DIVISION	
	APPROVED:  PUBLIC WORKS DIRECTOR/      DATE 1/29/14 CITY ENGINEER	<b>EROSION CONTROL NETTING (LANDSCAPING)</b>	



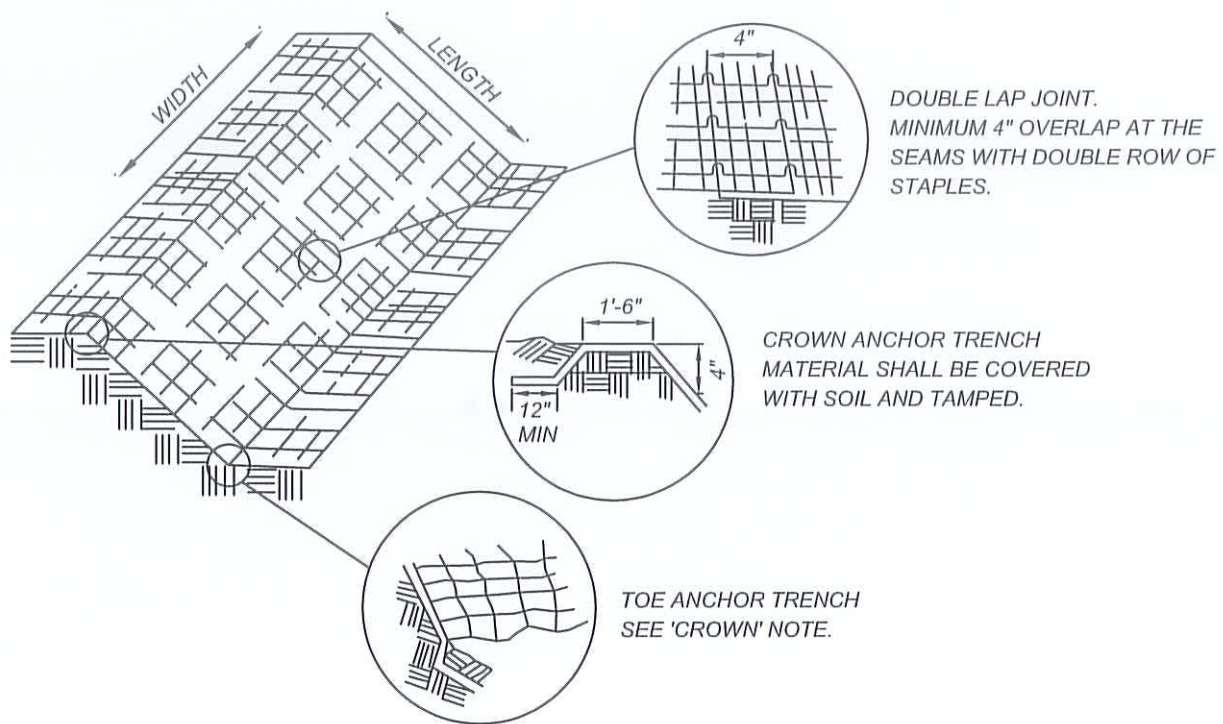



**NOTES:**

- 1.) GROUND COVER / SHRUBS MAY BE PLANTED THROUGH THE FABRIC.
- 2.) THE FABRIC SHALL BE INSTALLED ON GROUND A MINIMUM OF 48 HOURS PRIOR TO PLANTING TO ALLOW FABRIC TO SETTLE.
- 3.) HOLES FOR PLANTING SHALL BE MADE WITH SHARP KNIVES OR SHEARS.
- 4.) FABRIC IS TO BE FASTENED USING No 11 GAUGE WIRE. 'U' SHAPED WITH 1" CROWN AND LESS 12" IN LENGTH OR PREFABRICATED STAPLES.
- 5.) INSTALLATION PER MANUFACTURE'S SPECIFICATIONS.
- 6.) DRIP IRRIGATION TO BE INSTALLED UNDER FABRIC.
- 7.) NETTING TO BE USED ON SLOPES GREATER THAN 4:1

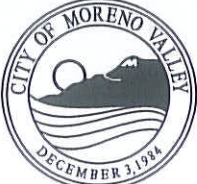
NOT TO SCALE

	RECOMMENDED:  1/21/14 DIVISION MANAGER      DATE	<h2 style="margin: 0;">CITY OF MORENO VALLEY</h2> <p style="margin: 0;">PARKS AND COMMUNITY SERVICES DEPARTMENT</p>	STANDARD PLAN <b>MVLI-523B-0</b>
	APPROVED:  1/29/14 PUBLIC WORKS DIRECTOR / DATE CITY ENGINEER	<h3 style="margin: 0;">EROSION CONTROL NETTING (LANDSCAPING)</h3>	

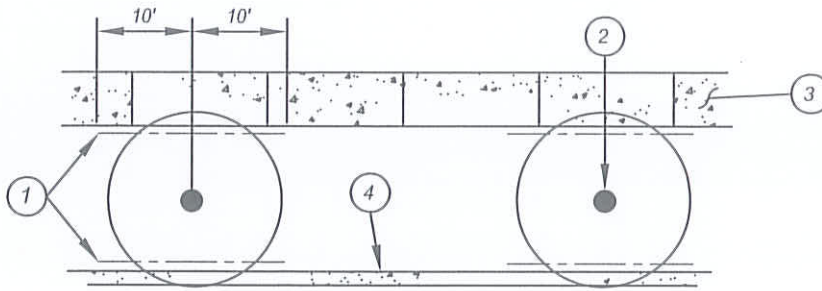

**PLAN**

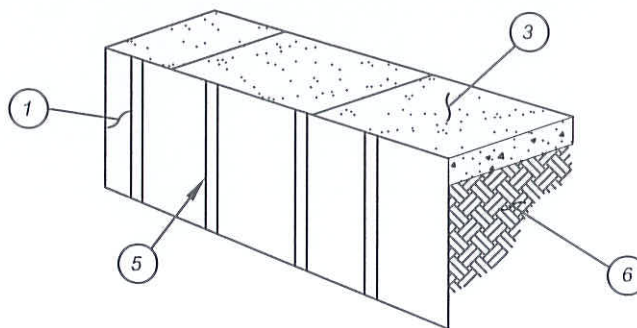

**ELEVATION**

**LEGEND:**

- (1) 24" DEEP LINEAR ROOT BARRIER (PER PLAN AS SPECIFIED). INSTALL IN TRENCH WITH VERTICAL RIBS FACING TOWARDS THE TREE. TOP OF BARRIER TO EXTEND TO TOP OF CURB OR WALK, OR 1" ABOVE FINISH GRADE.
- (2) TREE TRUNK LOCATION.
- (3) CONCRETE SIDEWALK OR SLAB.
- (4) CONCRETE CURB OR SITE WALL.
- (5) VERTICAL RIBS.
- (6) COMPACTED SUBGRADE.

NOT TO SCALE



RECOMMENDED:  
*CS* 1.16.14  
 DIVISION MANAGER DATE  
 APPROVED:  
*[Signature]* 1/29/14  
 PUBLIC WORKS DIRECTOR / DATE  
 CITY ENGINEER

**CITY OF MORENO VALLEY**  
 FINANCIAL & MANAGEMENT SERVICES DEPARTMENT - SPECIAL DISTRICTS DIVISION

**LINEAR ROOT BARRIER**

STANDARD PLAN  
**MVLI-524A-0**

SHEET 1 OF 2

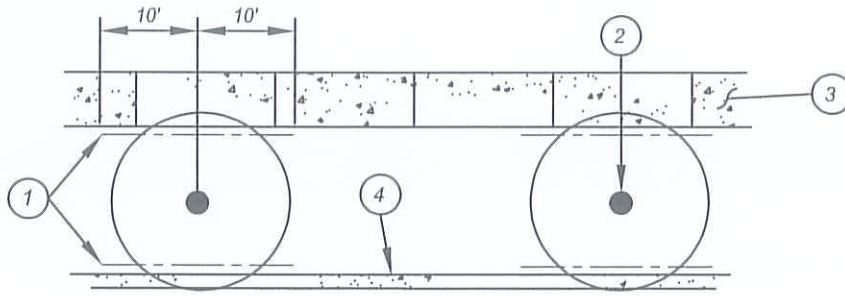

**PLAN**

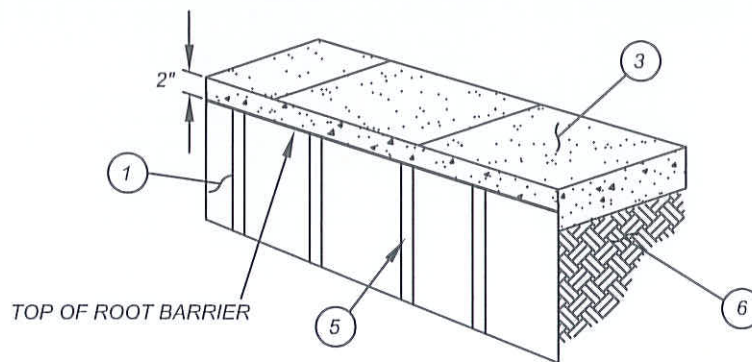

**ELEVATION**

**LEGEND:**

- ① 24" DEEP LINEAR ROOT BARRIER (PER PLAN AS SPECIFIED). INSTALL IN TRENCH WITH VERTICAL RIBS FACING TOWARDS THE TREE. TOP OF BARRIER TO EXTEND TO TOP OF CURB OR WALK, OR 1" ABOVE FINISH GRADE.
- ② TREE TRUNK LOCATION.
- ③ CONCRETE SIDEWALK OR SLAB.
- ④ CONCRETE CURB OR SITE WALL.
- ⑤ VERTICAL RIBS.
- ⑥ COMPACTED SUBGRADE.

NOT TO SCALE

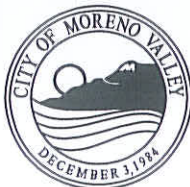

RECOMMENDED:  
 [Signature] 1/21/14  
 DIVISION MANAGER DATE  
 APPROVED:  
 [Signature] 1/29/14  
 PUBLIC WORKS DIRECTOR/ DATE  
 CITY ENGINEER

**CITY OF MORENO VALLEY**  
 PARKS AND COMMUNITY SERVICES DEPARTMENT

**LINEAR ROOT BARRIER**

STANDARD PLAN  
**MVLI-524B-0**

SHEET 2 OF 2



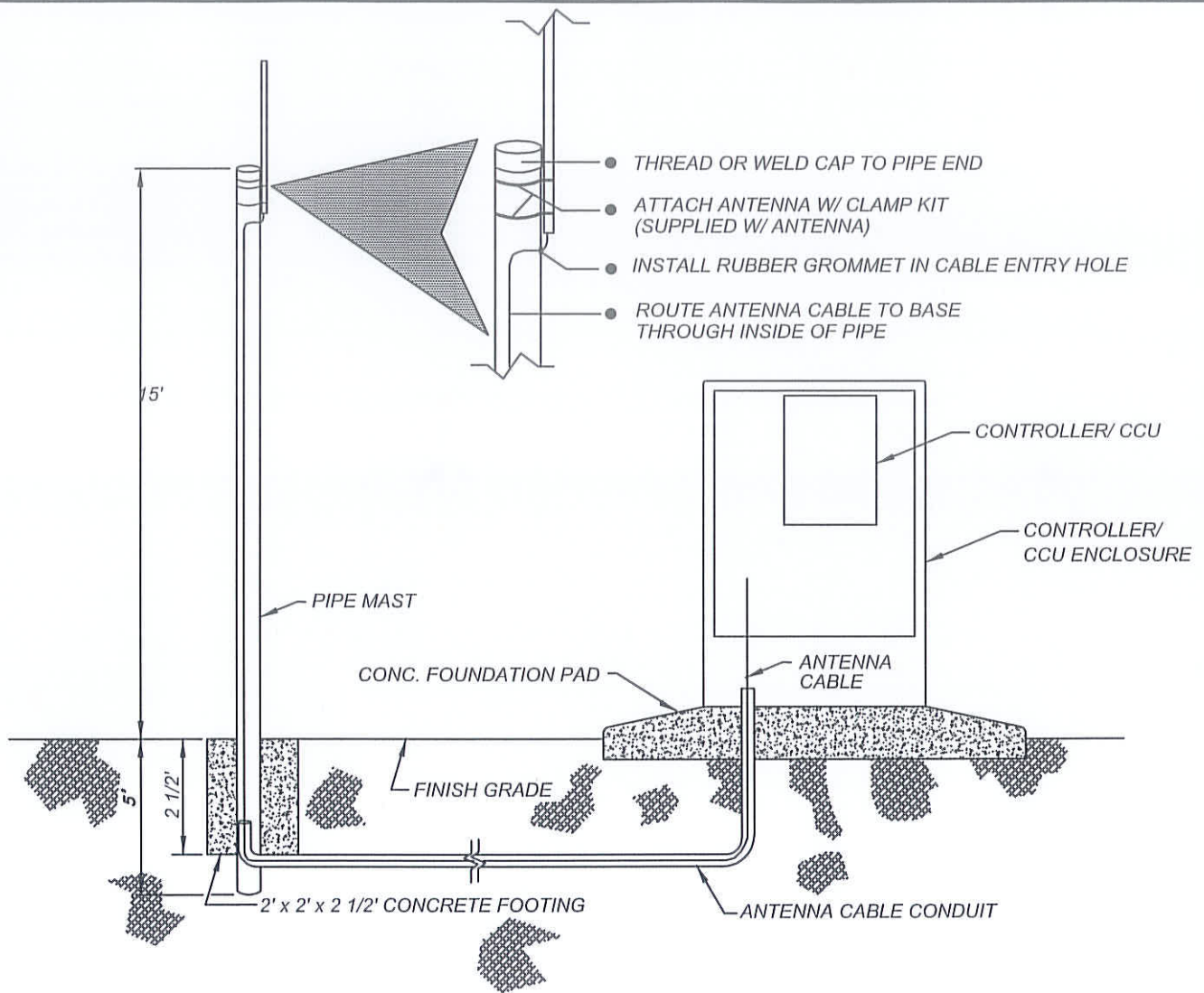

**NOTES:**

- 1) RADIO ANTENNA MAST SHALL BE 2" TREADED STEEL PIPE STOCK & FITTINGS.
- 2) ANTENNA MAST SURFACE COATING SHALL BE GLYD-ZINC Y-5537 - GREY-GREEN (OR APPROVED EQUAL)
- 3) ANTENNA LEAD WIRE SWEEPS / CONDUIT TO BE SCHD 40 PVC ALL SWEEPS TO BE 1" MIN DIA EXTEND CONDUIT ALONG THE ENTIRE REACH OF LEAD WIRE PATH, ENDING IN CCU ENCLOSURE
- 4) ANTENNA CABLE SHALL EXTEND INTO ENCLOSURE 18" PAST END OF SWEEP.
- 5) SEE CITY STANDARD EQUIPMENT LIST FOR MANUFACTURER

NOT TO SCALE

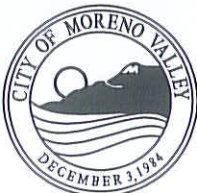

RECOMMENDED:  
 COS 1.16.14  
 DIVISION MANAGER DATE  
 APPROVED:  
 [Signature] 1/29/14  
 PUBLIC WORKS DIRECTOR / DATE  
 CITY ENGINEER

**CITY OF MORENO VALLEY**  
 FINANCIAL & MANAGEMENT SERVICES DEPARTMENT - SPECIAL DISTRICTS DIVISION

**CLUSTER CONTROL UNIT  
 RADIO LINK ANTENNA &  
 ENCLOSURE DETAIL**

STANDARD PLAN  
**MVLI-530-0**

SHEET 1 OF 1



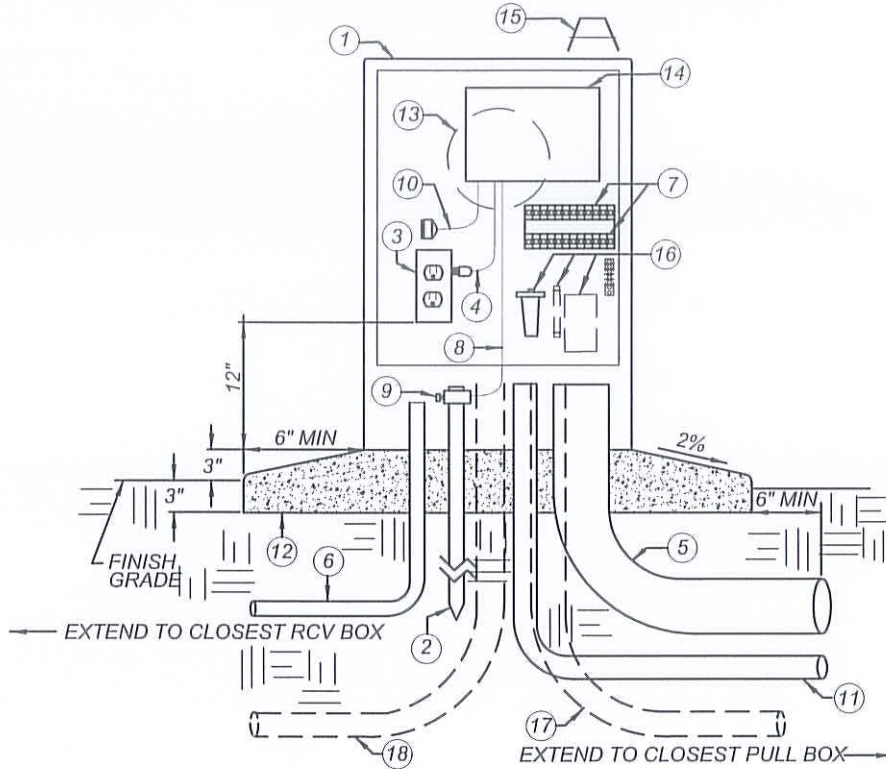



**LEGEND:**

- ① ELECTRICAL METER/IRRIGATION CONTROLLER ENCLOSURE W/ 110 VAC SERVICE PANEL-DOUBLE DOOR-STAINLESS STEEL
- ② 5/8" x 8' COPPER-CLAD GROUNDING ROD (GROUND 110 & CONTROLLER)
- ③ DUPLEX OUTLET (CONDUIT PATH TO SERVICE PANEL PER CODE). INSTALL W/ SURGE ARRESTOR - ISOBAR ULTRABLOCK 428
- ④ APPLIANCE GRADE 110 VAC 3-WIRE CONDUCTOR POWER CORD (SIZED TO REACH DUPLEX OUTLET). SECURE TO CONTROLLER CABINET
- ⑤ 3" SCH. 40 E.C. SWEEP ELL FOR 14 GA. UF CONTROL WIRE ONLY
- ⑥ 3/4" SCH. 40 E.C. SWEEP ELL W/ NYLON PULL ROPE FOR FUTURE MOISTURE SENSOR WIRING
- ⑦ TERMINAL STRIP(S) FOR CONNECTION OF 14 GA. UF FIELD WIRE FROM SWEEP. USE 16 GA. UTILITY WIRE TO CONNECT
- ⑧ #10 SOLID COPPER WIRE FROM GROUNDING ROD TO CONTROLLER GROUND LUG
- ⑨ BRASS / BRONZE GROUND CLAMP
- ⑩ ETHERNET (RS232 PORT INCLUDED)
- ⑪ TELEMETRY CONDUIT - 1 1/2" SCH 40. EXTEND PE 39 CABLE INTO ENCLOSURE 18" MIN. FROM END OF SWEEP (USE FOR MAXICOM WIRE LINK / FLOW SENSOR WIRE LINK @ 1 PER EA.)
- ⑫ 6" THICK CONCRETE FOOTING POURED ON COMPACTED SUBGRADE (95% RELATIVE COMPACTION). RADIUS EDGES @ 1/2"
- ⑬ ELECTRIC METER
- ⑭ IRRIGATION CONTROLLER - MODEL # PER PLAN CALL-OUT WITH REMOTE CONTROL ACCTUATOR INTERFACE-PER PLAN
- ⑮ ANTENNA - RADIO LINKED MAXICOM ONLY - MODEL # PER PLAN CALL-OUT
- ⑯ FLOW SENSING COMPONENTS (INSTALL IF SHOWN ON PLAN) - MODEL #'S PER PLAN CALL-OUT
- ⑰ 2 1/2" SCH 40 ELECTRICAL CONDUIT
- ⑱ 1" SCH 40 ELECTRICAL CONDUIT

**NOTES:**

- 1) COMMON WIRE TO BE 12 GA. WHITE. PILOT WIRES TO BE 14 GA. BLACK.
- 2) NO SPLICES ALLOWED BETWEEN TERMINAL STRIP AND RCV.
- 3) INSTALL ONE (1) EXTRA PILOT WIRE (RED) TO FARTHEST RCV IN ANY / ALL DIRECTIONS FROM ENCLOSURE. LOOP INTO EACH VALVE BOX ALONG WIRE PATH.
- 4) IF FLOW SENSOR TO BE INSTALLED, INCLUDE 3/4" CONDUIT PATH FROM ENCLOSURE TO SENSOR VAULT.
- 5) SEE CITY STANDARD EQUIPMENT LIST FOR MANUFACTURER.

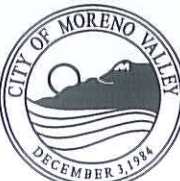
NOT TO SCALE

	RECOMMENDED:  1.76.14 DIVISION MANAGER      DATE	<h2 style="margin: 0;">CITY OF MORENO VALLEY</h2> <p style="margin: 0;">FINANCIAL &amp; MANAGEMENT SERVICES DEPARTMENT - SPECIAL DISTRICTS DIVISION</p>	STANDARD PLAN <h3 style="margin: 0;">MVLI-531A-0</h3>
	APPROVED:  1/29/14 PUBLIC WORKS DIRECTOR / DATE CITY ENGINEER	<h2 style="margin: 0;">CONTROLLER / SATELLITE ENCLOSURE DETAIL</h2>	

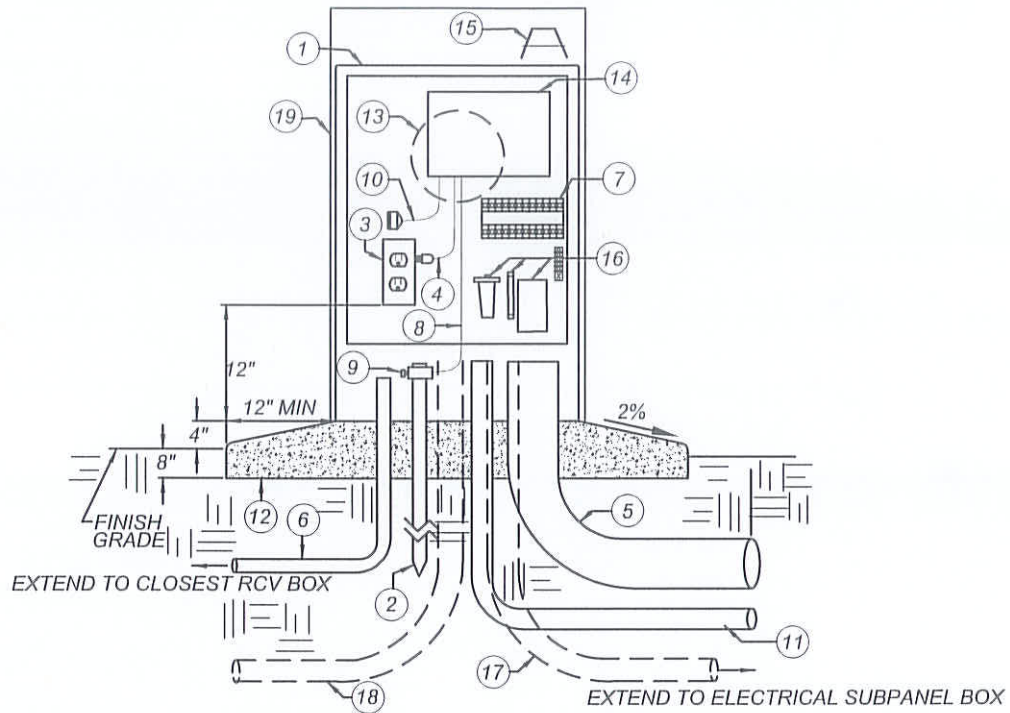



**LEGEND:**

- ① ELECTRICAL METER/IRRIGATION CONTROLLER ENCLOSURE PER SPECIFICATIONS
- ② 5/8" x 8' COPPER-CLAD GROUNDING ROD (GROUND 110 & CONTROLLER)
- ③ DUPLEX OUTLET (CONDUIT PATH TO SERVICE PANEL PER CODE). INSTALL W/ SURGE ARRESTOR - ISOBAR ULTRABLOCK 428
- ④ APPLIANCE GRADE 110 VAC 3-WIRE CONDUCTOR POWER CORD (SIZED TO REACH DUPLEX OUTLET). SECURE TO CONTROLLER CABINET
- ⑤ 4" SCH 40 E.C. SWEEP ELL FOR UF CONTROL WIRE ONLY
- ⑥ 3/4" SCH 40 E.C. SWEEP ELL W/ NYLON PULL ROPE FOR FUTURE MOISTURE SENSOR WIRING
- ⑦ TERMINAL STRIP FOR CONNECTION OF UF FIELD WIRE FROM SWEEP.
- ⑧ TERMINAL STRIP TO CONTROLLER (TYP.)
- ⑨ #6 SOLID COPPER WIRE FROM GROUNDING ROD TO CONTROLLER GROUND LUG
- ⑩ BRASS / BRONZE GROUND CLAMP
- ⑪ TELEMETRY CONDUIT - 3/4". EXTEND RAIN / WEATHER SENSOR CABLE INTO ENCL 36" MIN. FROM END OF SWEEP
- ⑫ 12" THICK CONCRETE FOOTING POURED ON COMPACTED SUBGRADE (95% COMPACTION). RADIUS EDGES @ 1/2"
- ⑬ ELECTRIC METER
- ⑭ IRRIGATION CONTROLLER - MODEL # PER PLAN CALL-OUT
- ⑮ RAIN GAUGE / WEATHER SENSOR - MODEL # PER PLAN CALL-OUT
- ⑯ FLOW SENSING COMPONENTS (INSTALL IF SHOWN ON PLAN) - MODEL #'S PER PLAN CALL-OUT
- ⑰ 2 1/2" SCH 40 ELECTRICAL CONDUIT
- ⑱ 1" SCH 40 ELECTRICAL CONDUIT
- ⑲ STAINLESS STEEL VANDAL PROOF MESH COVER PER SPECIFICATIONS

**NOTES:**

- 1) COMMON WIRE TO BE WHITE, PER SPECIFICATIONS. PILOT WIRES TO BE SIZED AND COLOR PER SPECIFICATIONS.
- 2) NO SPLICES ALLOWED BETWEEN TERMINAL STRIP AND RCV.
- 3) INSTALL EXTRA WIRES PER SPECIFICATION TO FARTHEST RCV IN ANY / ALL DIRECTIONS FROM ENCLOSURE. LOOP INTO EACH VALVE BOX ALONG WIRE PATH.
- 4) IF FLOW SENSOR AND/OR MASTER VALVE IS INSTALLED, INCLUDE 3/4" CONDUIT PATH FROM ENCLOSURE TO VAULTS.
- 5) SEE CITY STANDARD EQUIPMENT LIST FOR MANUFACTURER.

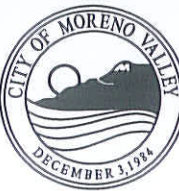
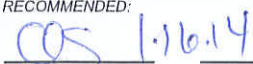
NOT TO SCALE

	RECOMMENDED:  DIVISION MANAGER      DATE	<h2 style="margin: 0;">CITY OF MORENO VALLEY</h2> <p style="margin: 0;">FINANCIAL &amp; MANAGEMENT SERVICES DEPARTMENT - SPECIAL DISTRICTS DIVISION</p>	STANDARD PLAN <h3 style="margin: 0;">MVLI-531B-0</h3>
	APPROVED:  PUBLIC WORKS DIRECTOR / DATE CITY ENGINEER	<h3 style="margin: 0;">SMART CONTROLLER ENCLOSURE DETAIL</h3>	SHEET 2 OF 2



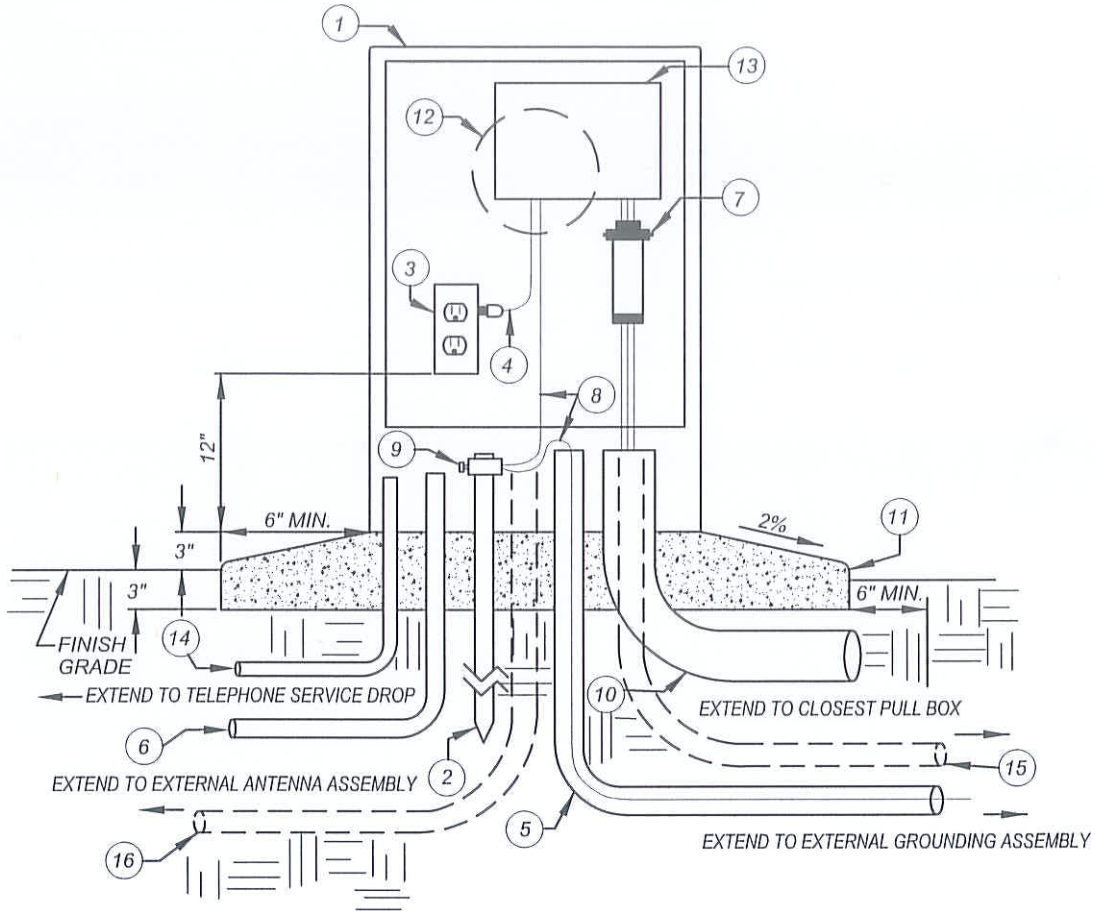

**LEGEND:**

- ① ELECTRICAL METER/IRRIGATION CONTROLLER ENCLOSURE W/ 110 VAC SERVICE PANEL-DOUBLE DOOR-STAINLESS STEEL
- ② 5/8" x 8' COPPER-CLAD GROUNDING ROD (GROUND 110 & CONTROLLER)
- ③ DUPLEX OUTLET (CONDUIT PATH TO SERVICE PANEL PER CODE). INSTALL W/ SURGE ARRESTOR - ISOBAR ULTRAFAX
- ④ APPLIANCE GRADE 110 VAC 3-WIRE CONDUCTOR POWER CORD (SIZED TO REACH DUPLEX OUTLET). SECURE TO CONTROLLER CABINET
- ⑤ 1" SCH 40 E.C. SWEEP ELL FOR EXTERNAL GROUNDING ASSEMBLY
- ⑥ 1-1/2" SCH 40 E.C. SWEEP ELL FOR EXTERNAL ANTENNA ASSEMBLY (MAXICOM RADIO LINK ONLY)
- ⑦ TELEMETRY CABLE SURGE ARRESTOR (RAINBIRD MSP-1). INSTALL PER MFG.'S DIRECTIONS
- ⑧ #10 SOLID COPPER WIRE FROM GROUNDING ROD TO CONTROLLER GROUND LUG-GREEN INSULATION
- ⑨ BRASS / BRONZE GROUND CLAMP
- ⑩ TELEMETRY CONDUIT - 1-1/2" SCH 40. EXTEND PE 39 CABLE 18" MIN. FROM TOP END OF SWEEP (ELIMINATE SWEEP IF RADIO LINKED MAXICOM)
- ⑪ 6" THICK CONCRETE FOOTING POURED ON COMPACTED SUBGRADE (95% RELATIVE COMPACTION). RADIUS EDGES @ 1/2"
- ⑫ ELECTRIC METER
- ⑬ CCU PER PLAN CALL-OUT
- ⑭ SCH. 40 PVC SWEEP ELL W/ NYLON PULL ROPE FOR TELEPHONE SERVICE DROP - SIZE PER PLAN
- ⑮ 2-1/2" SCH 40 ELECTRICAL CONDUIT
- ⑯ 1" SCH 40 ELECTRICAL CONDUIT

NOT TO SCALE

	RECOMMENDED: <i>COS 1.16.14</i> DIVISION MANAGER      DATE	<b>CITY OF MORENO VALLEY</b> FINANCIAL & MANAGEMENT SERVICES DEPARTMENT - SPECIAL DISTRICTS DIVISION	
	APPROVED: <i>[Signature]</i> PUBLIC WORKS DIRECTOR/      DATE CITY ENGINEER	<b>CLUSTER CONTROL UNIT ENCLOSURE DETAIL</b>	

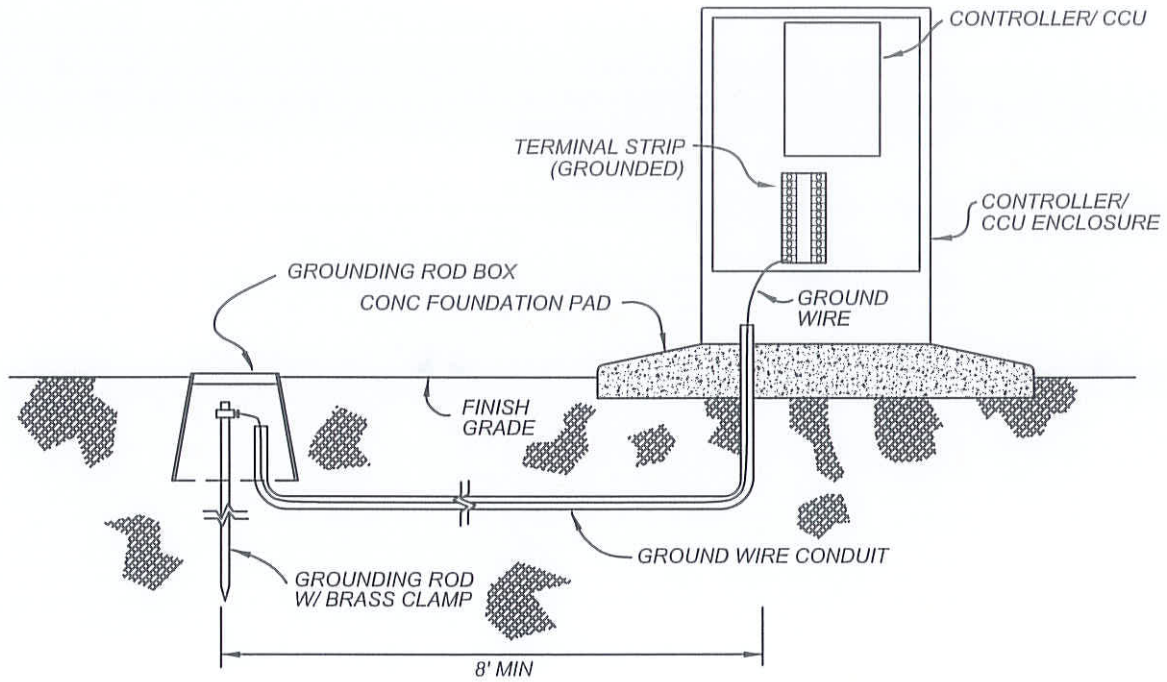

**NOTES:**

- 1) GROUND WIRE SHALL BE No 10 COPPER (INSULATED - GREEN).
- 2) GROUNDING ROD SHALL BE 5/8" x 8'-0" COPPER CLAD.
- 3) ATTACH GROUND WIRE TO GROUNDING ROD USING BRASS GROUND ROD CLAMP.
- 4) ENCLOSE GROUND ROD IN 10 - INCH ROUND PLASTIC VALVE BOX W / LOCKING LID.
- 5) CONNECT FIELD GROUND WIRE TO TERMINAL STRIP.
- 6) SWEEPS / CONDUIT TO BE 1" SCH 80 PVC. EXTEND CONDUIT ALONG THE ENTIRE REACH OF GROUND WIRE PATH, ENDING IN GROUND ROD BOX.

NOT TO SCALE

	RECOMMENDED: DIVISION-MANAGER      DATE 1-16-14	<b>CITY OF MORENO VALLEY</b> FINANCIAL & MANAGEMENT SERVICES DEPARTMENT - SPECIAL DISTRICTS DIVISION	STANDARD PLAN <b>MVLI-533-0</b>
	APPROVED: PUBLIC WORKS DIRECTOR/      DATE 1/29/14 CITY ENGINEER	<b>EXTERNAL GROUND ROD ASSEMBLY DETAIL</b>	



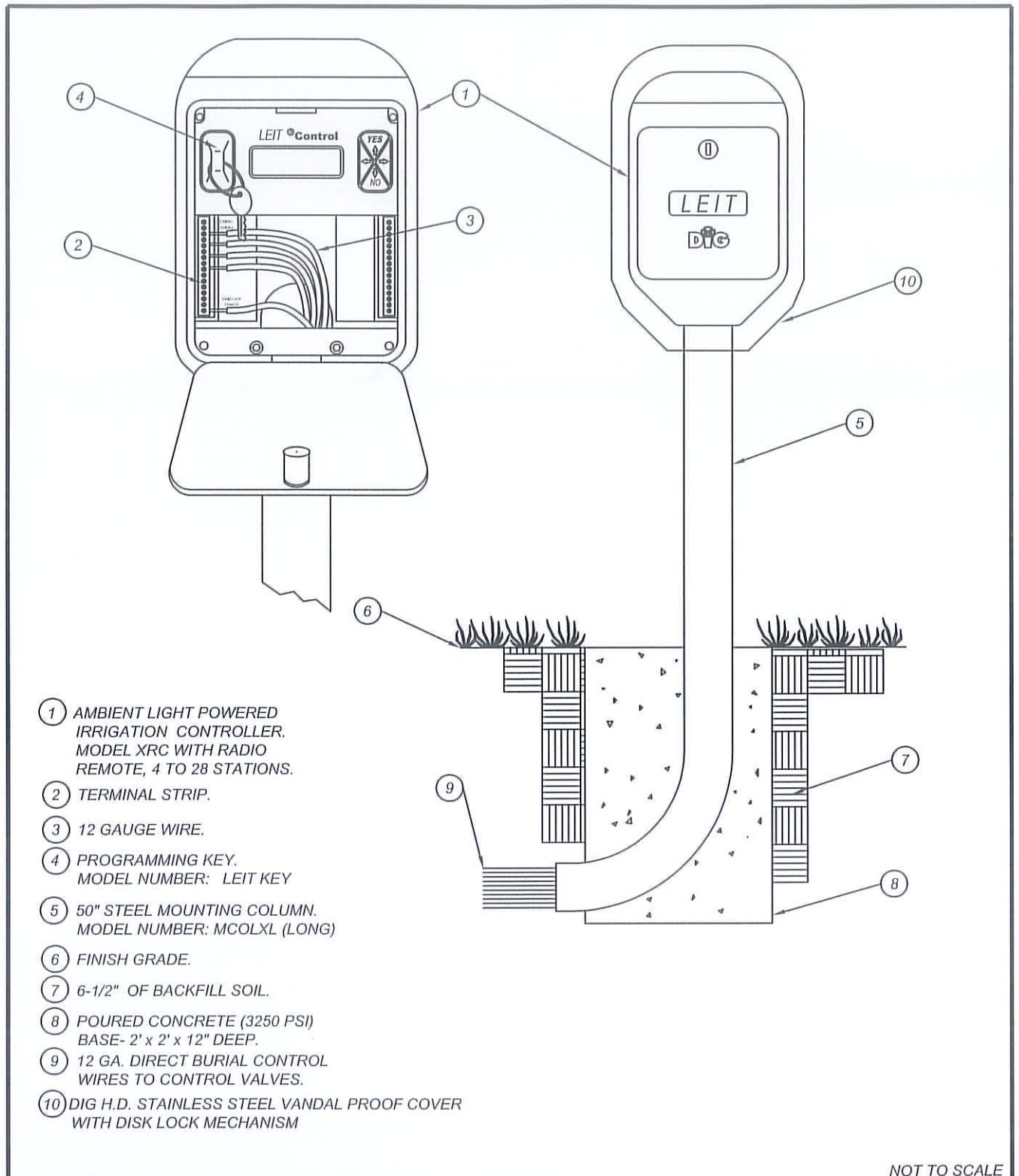

- 1 AMBIENT LIGHT POWERED IRRIGATION CONTROLLER. MODEL XRC WITH RADIO REMOTE, 4 TO 28 STATIONS.
- 2 TERMINAL STRIP.
- 3 12 GAUGE WIRE.
- 4 PROGRAMMING KEY. MODEL NUMBER: LEIT KEY
- 5 50" STEEL MOUNTING COLUMN. MODEL NUMBER: MCOLXL (LONG)
- 6 FINISH GRADE.
- 7 6-1/2" OF BACKFILL SOIL.
- 8 POURED CONCRETE (3250 PSI) BASE- 2' x 2' x 12" DEEP.
- 9 12 GA. DIRECT BURIAL CONTROL WIRES TO CONTROL VALVES.
- 10 DIG H.D. STAINLESS STEEL VANDAL PROOF COVER WITH DISK LOCK MECHANISM

NOT TO SCALE

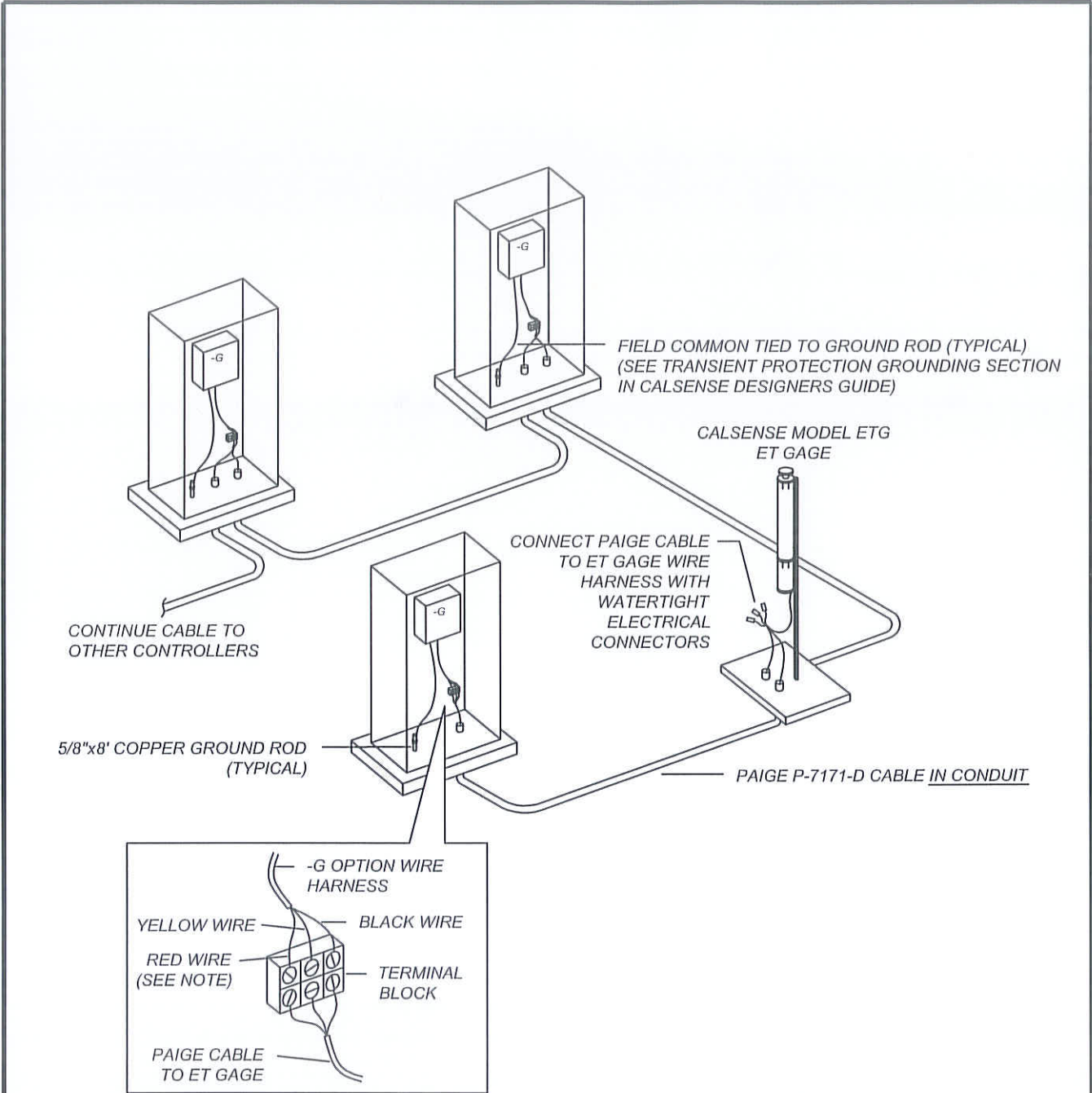

	RECOMMENDED: <i>COS</i> 1-16-14 DIVISION MANAGER      DATE	<b>CITY OF MORENO VALLEY</b> FINANCIAL & MANAGEMENT SERVICES DEPARTMENT - SPECIAL DISTRICTS DIVISION	STANDARD PLAN <b>MVLI-534-0</b>
	APPROVED:  1/29/14 PUBLIC WORKS DIRECTOR / DATE CITY ENGINEER	<b>LEIT XRC</b> <b>IRRIGATION CONTROLLER</b>	



**NOTES:**

- 1) THERE CAN BE A MAXIMUM OF 12 CONTROLLERS CONNECTED TO ONE ET GAGE WITH A TOTAL LENGTH OF CABLE NOT TO EXCEED 1,000 FEET.
- 2) CONNECT THE RED WIRE FROM THE -G WIRE HARNESS TO ONLY ONE CONTROLLER.

NOT TO SCALE

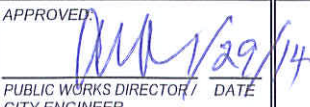
	RECOMMENDED:  / 1/21/14 DIVISION MANAGER / DATE	<h2 style="margin: 0;">CITY OF MORENO VALLEY</h2> <p style="margin: 0;">PARKS AND COMMUNITY SERVICES DEPARTMENT</p>	STANDARD PLAN <b>MVLI-535-0</b>
	APPROVED:  / 1/29/14 PUBLIC WORKS DIRECTOR / DATE CITY ENGINEER	<h3 style="margin: 0;">MULTIPLE CONTROLLERS USING ONE ET GAGE</h3>	

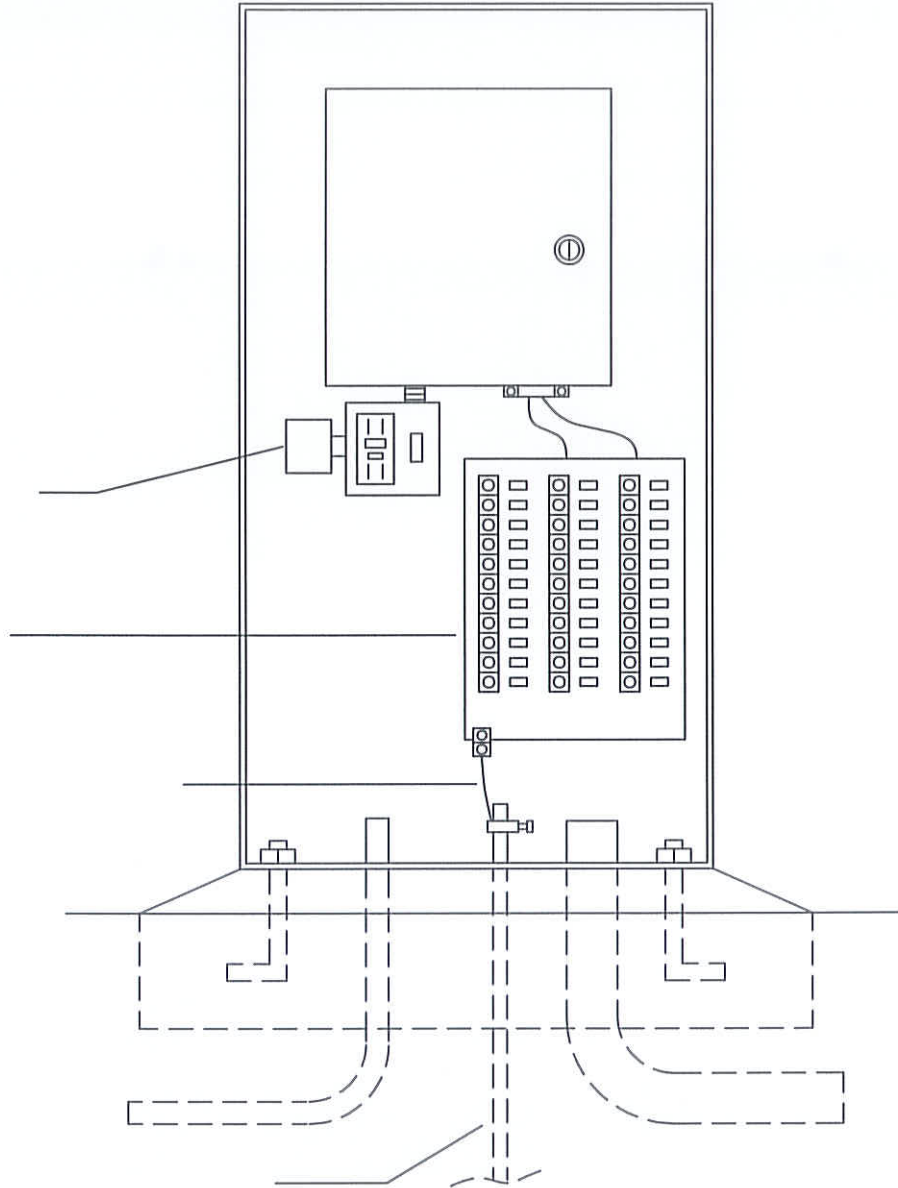

NOT TO SCALE

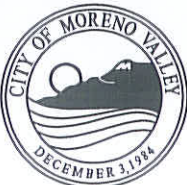

RECOMMENDED:  
*JA* 1/21/14  
 DIVISION MANAGER DATE

APPROVED:  
*MD* 1/29/14  
 PUBLIC WORKS DIRECTOR/ DATE  
 CITY ENGINEER

# CITY OF MORENO VALLEY

PARKS AND COMMUNITY SERVICES DEPARTMENT

## TYPICAL TRANSIENT PROTECTION INSTALLATION

STANDARD PLAN  
**MVLI-536-0**

SHEET 1 OF 1

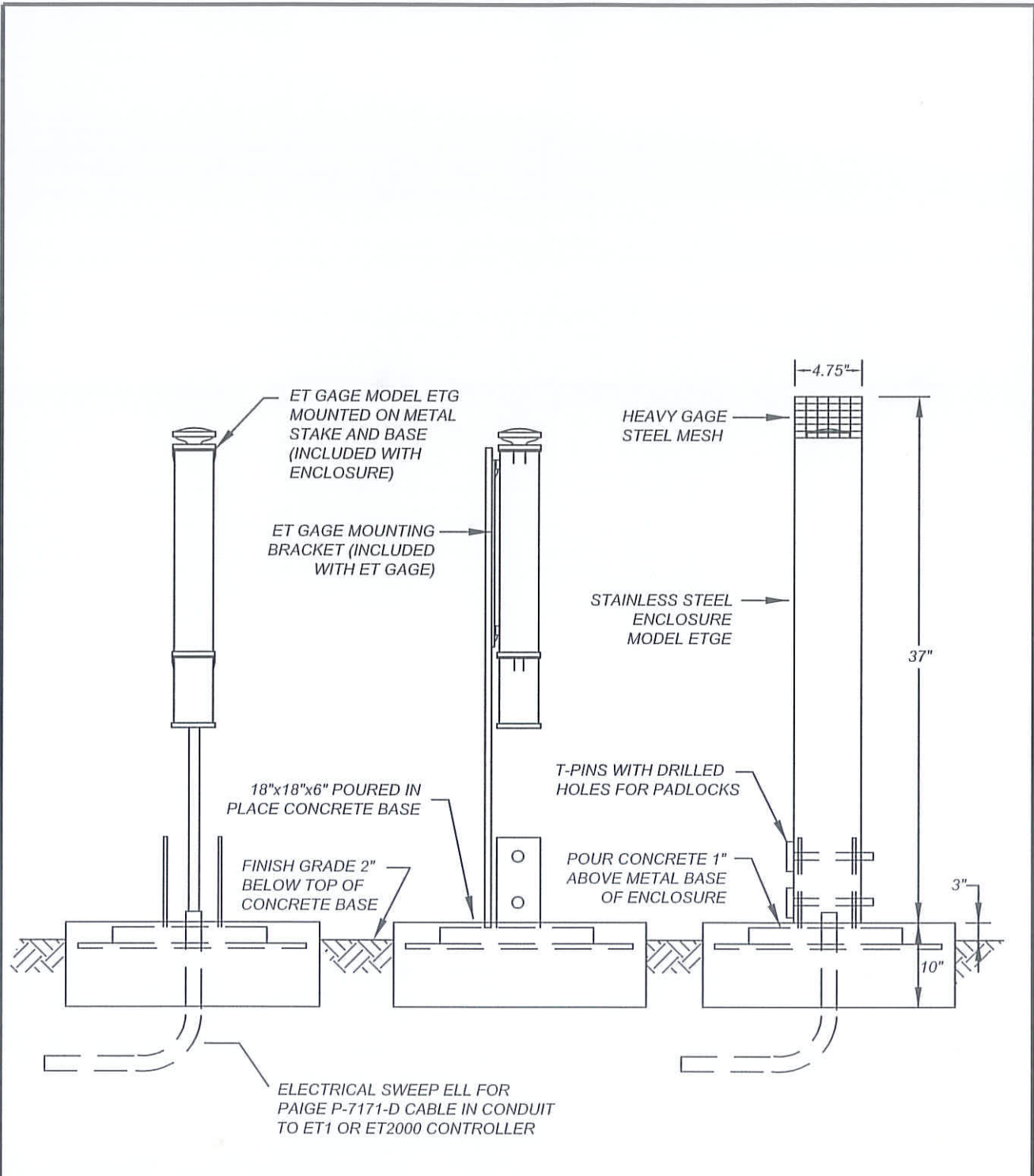

NOT TO SCALE

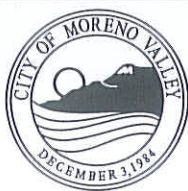
	RECOMMENDED: <i>[Signature]</i> 1/21/14 DIVISION MANAGER DATE	<b>CITY OF MORENO VALLEY</b> PARKS AND COMMUNITY SERVICES DEPARTMENT  <b>VANDAL RESISTANT ET GAGE ENCLOSURE</b>	STANDARD PLAN <b>MVLI-537-0</b>
	APPROVED: <i>[Signature]</i> 1/29/14 PUBLIC WORKS DIRECTOR DATE CITY ENGINEER		<b>SHEET 1 OF 1</b>



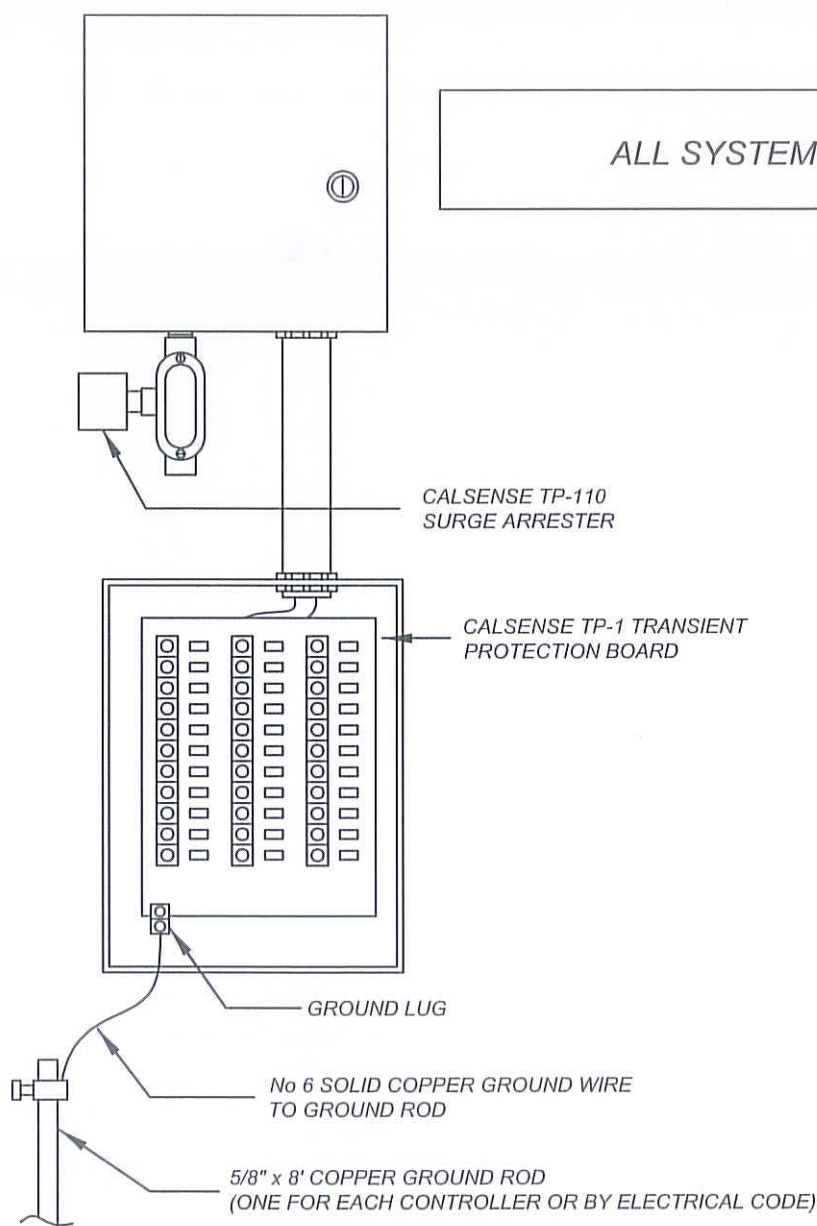

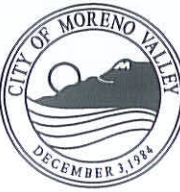

NOT TO SCALE

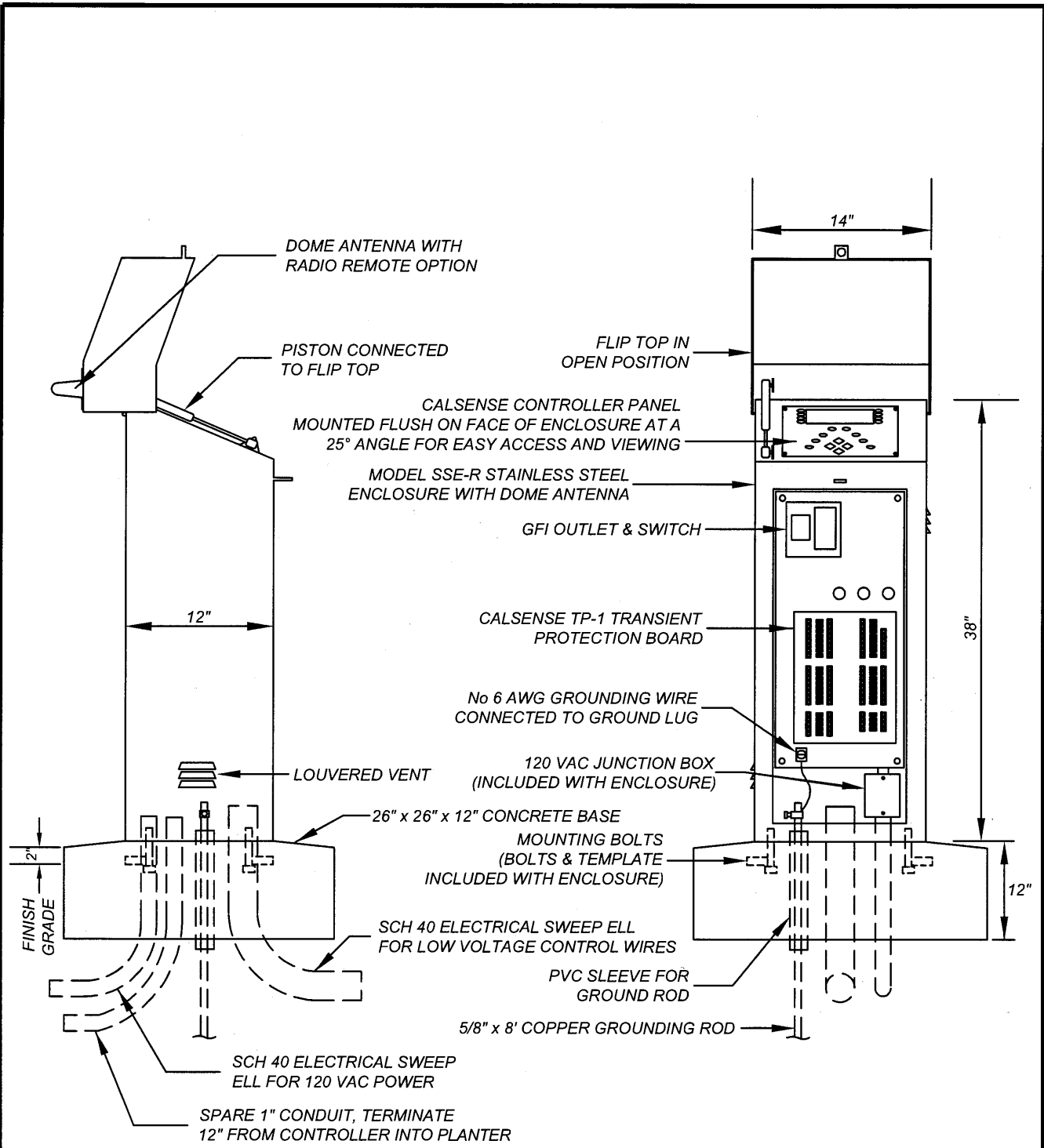
	RECOMMENDED: <i>[Signature]</i> 11/21/14 DIVISION MANAGER DATE	<b>CITY OF MORENO VALLEY</b> PARKS AND COMMUNITY SERVICES DEPARTMENT		
	APPROVED: <i>[Signature]</i> 1/29/14 PUBLIC WORKS DIRECTOR/ DATE CITY ENGINEER	<b>IRRIGATION CONTROLLER          GROUNDING INSTRUCTION</b>		STANDARD PLAN <b>MVLI-538-0</b>
				SHEET 1 OF 1



TYPICAL DETAIL, ACTUAL INSTALLATION MAY VARY PER SPECIFIC PRODUCT UTILIZED, AS APPROVED

NOT TO SCALE

	RECOMMENDED:  DIVISION MANAGER	12/21/16 DATE	<b>CITY OF MORENO VALLEY</b> PARKS AND COMMUNITY SERVICES DEPARTMENT	STANDARD PLAN
	APPROVED:  PUBLIC WORKS DIRECTOR / CITY ENGINEER	1/20/17 DATE		<b>IRRIGATION CONTROLLER ENCLOSURE INSTALLATION DETAIL</b>

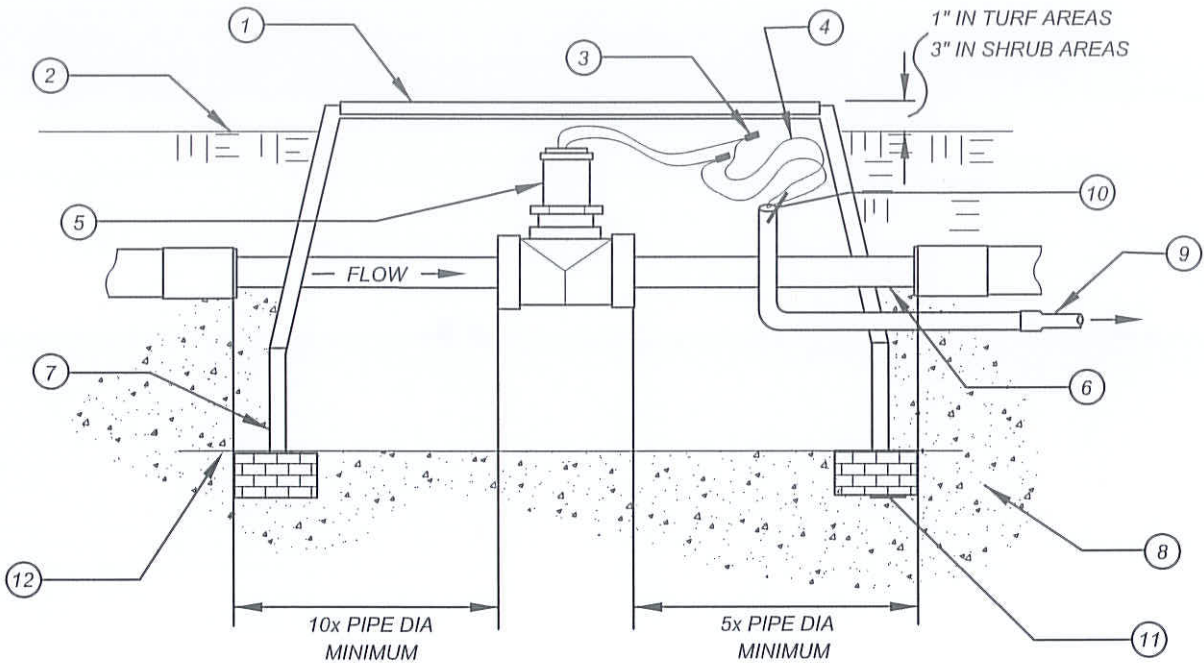

**LEGEND:**

- ① JUMBO RECTANGULAR PLASTIC VALVE BOX & LOCKING COVER (PER PLAN AS SPECIFIED).
- ② FINISH GRADE
- ③ WATERPROOF CONNECTION (REFER TO STANDARD MVLI-545A-0)
- ④ TWO CONDUCTOR SHIELDED CABLE - ROUTED TO CONTROLLER VIA CONDUIT.
- ⑤ FLOW SENSOR (PER PLAN AS SPECIFIED)
- ⑥ PIPE CHOKE - REDUCE TO NEXT SIZE BELOW MAINLINE PIPE SIZE
- ⑦ VALVE BOX EXTENSION (AS NECESSARY)
- ⑧ PEA GRAVEL DRAIN SUMP - 30" DIA x 6" DEEP MINIMUM
- ⑨ 3/4" E.C. WIRE PATH FROM SENSOR BOX TO MASTER VALVE AND/OR IRRIGATION CONTROLLER
- ⑩ PLUMBERS PUTTY IN HOLE
- ⑪ CONCRETE BRICK, TYPICAL OF 4
- ⑫ 1/4" GALVANIZED WIRE MESH

NOT TO SCALE

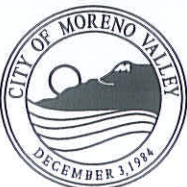

RECOMMENDED:  
 COS 1.16.14  
 DIVISION MANAGER DATE  
 APPROVED:  
 [Signature] 1/29/14  
 PUBLIC WORKS DIRECTOR/ DATE  
 CITY ENGINEER

**CITY OF MORENO VALLEY**  
 FINANCIAL & MANAGEMENT SERVICES DEPARTMENT - SPECIAL DISTRICTS DIVISION

**FLOW SENSOR  
 ASSEMBLY DETAIL**

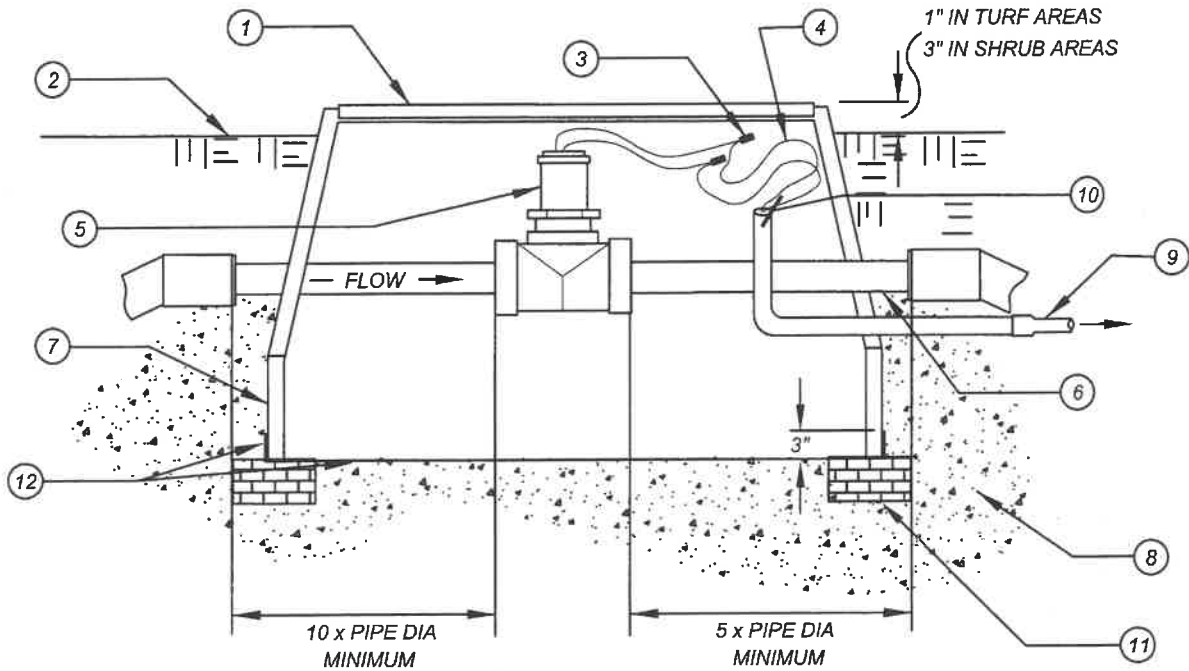

STANDARD PLAN  
**MVLI-540A-0**  
 SHEET 1 OF 3



**LEGEND:**

- ① JUMBO RECTANGULAR PLASTIC VALVE BOX & LOCKING COVER (PER SPECIFICATIONS)
- ② FINISH GRADE
- ③ WATERPROOF CONNECTION (PER SPECIFICATIONS)
- ④ TWO CONDUCTOR SHIELDED CABLE - ROUTED TO CONTROLLER VIA CONDUIT.
- ⑤ FLOW SENSOR (PER PLAN AS SPECIFIED)
- ⑥ PIPE CHOKE - REDUCE TO NEXT SIZE BELOW MAINLINE PIPE SIZE
- ⑦ VALVE BOX EXTENSION (AS NECESSARY)
- ⑧ PEA GRAVEL DRAIN SUMP - 30" DIA x 6" DEEP MINIMUM
- ⑨ 3/4" E.C. WIRE PATH FROM SENSOR BOX TO MASTER VALVE AND/OR IRRIGATION CONTROLLER
- ⑩ DUCT SEAL
- ⑪ CONCRETE BRICK, TYPICAL OF 4
- ⑫ 1/4" STAINLESS STEEL WIRE MESH, TYPE 316

NOT TO SCALE

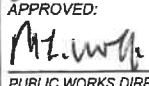
	RECOMMENDED:  6/20/19 DIVISION MANAGER      DATE	<h2 style="margin: 0;">CITY OF MORENO VALLEY</h2> <p style="margin: 0;">PARKS AND COMMUNITY SERVICES DEPARTMENT</p>	STANDARD PLAN <h3 style="margin: 0;">MVLI-540B-0</h3>
	APPROVED:  7/30/19 PUBLIC WORKS DIRECTOR / DATE CITY ENGINEER	<h2 style="margin: 0;">FLOW SENSOR ASSEMBLY DETAIL</h2>	



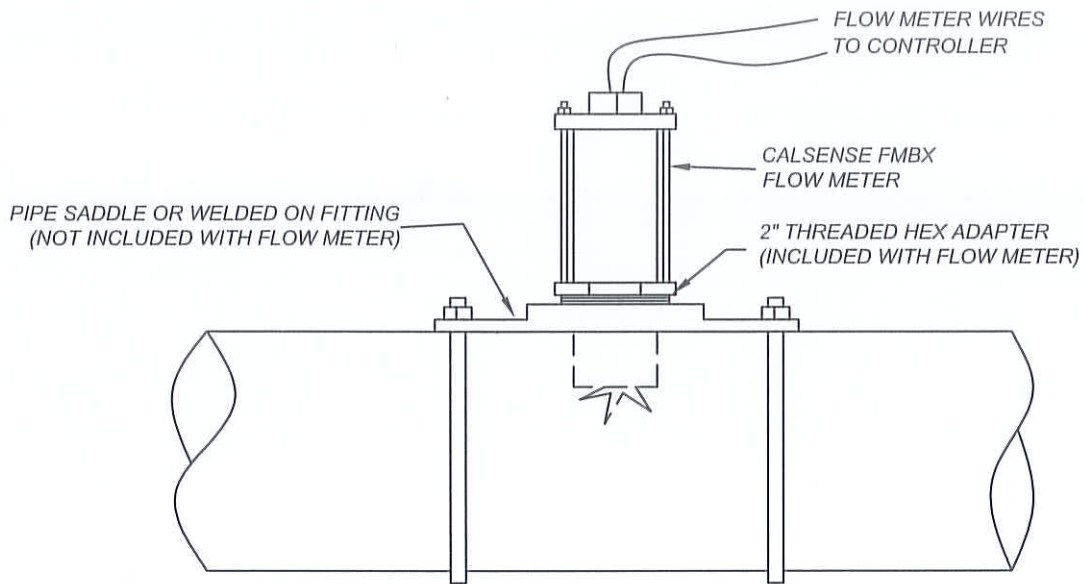



**NOTES:**

1. FOR USE ON PARKS AND COMMUNITY SERVICES PROJECTS.
2. REQUIRES INSPECTION FROM CALSENSE AND PARKS AND COMMUNITY SERVICES.

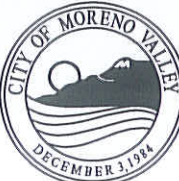
NOT TO SCALE

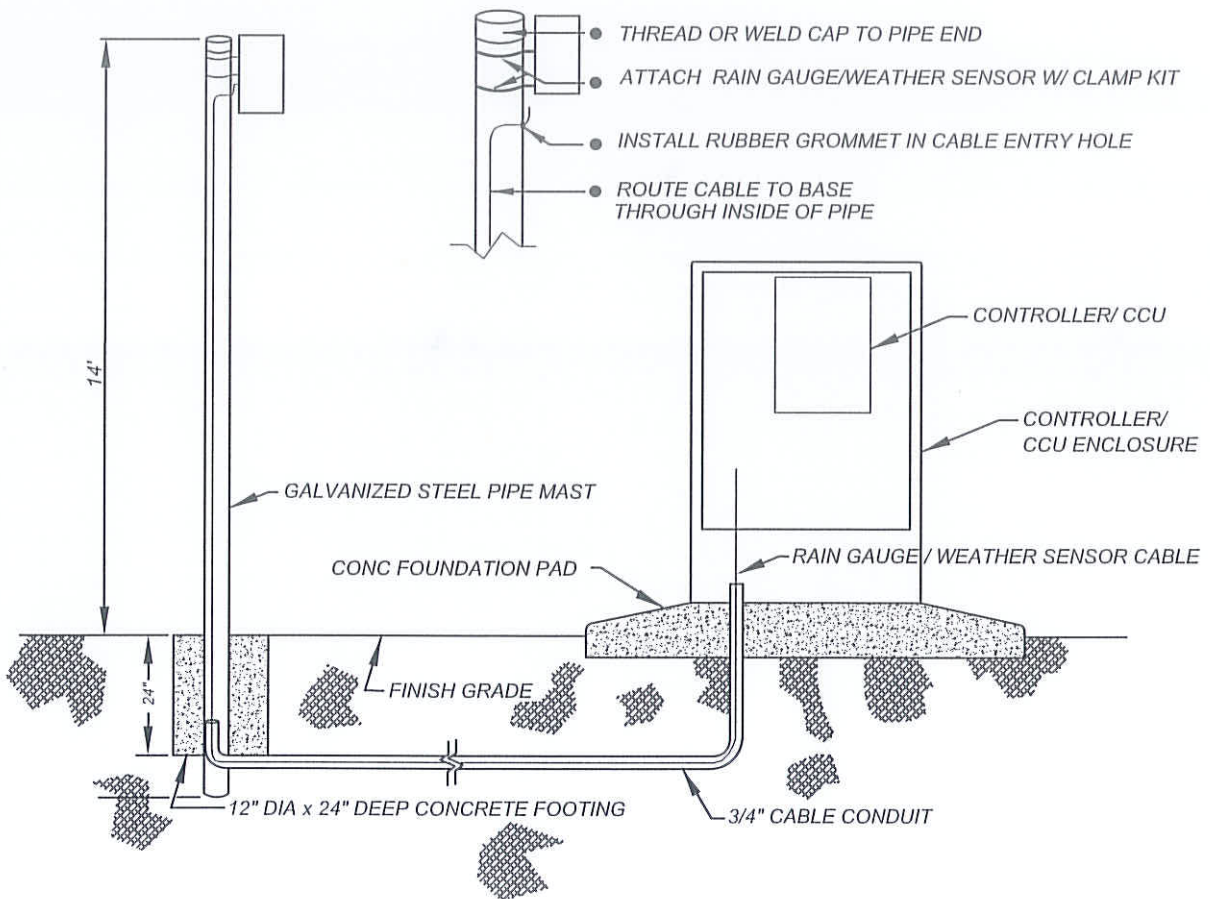

	RECOMMENDED:  1/21/14 DIVISION MANAGER      DATE	<h2 style="margin: 0;">CITY OF MORENO VALLEY</h2> <p style="margin: 0;">PARKS AND COMMUNITY SERVICES DEPARTMENT</p>	
	APPROVED:  1/29/14 PUBLIC WORKS DIRECTOR / DATE CITY ENGINEER	<h3 style="margin: 0;">FMBX FLOW METER INSTALLATION</h3>	



**NOTES:**

- 1) RAIN GAUGE / WEATHER SENSOR MAST SHALL BE MINIMUM 2" GALVANIZED STEEL PIPE STOCK & FITTINGS.
- 2) RAIN GAUGE / WEATHER SENSOR SHALL BE TYPE SPECIFIED IN PLANS / SPECIFICATIONS.
- 3) WIRE SWEEPS / CONDUIT TO BE SCHEDULE 40 PVC. ALL SWEEPS TO BE 3/4" MIN DIA EXTEND CONDUIT ALONG THE ENTIRE REACH OF LEAD WIRE PATH, ENDING IN CCU ENCLOSURE
- 4) RAIN GAUGE / WEATHER SENSOR CABLE SHALL EXTEND INTO ENCLOSURE 18" PAST END OF SWEEP.

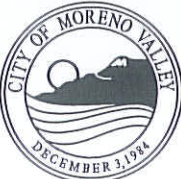
NOT TO SCALE

	RECOMMENDED:  1/21/14 DIVISION MANAGER DATE	<b>CITY OF MORENO VALLEY</b> PARKS AND COMMUNITY SERVICES DEPARTMENT  <b>RAIN GAUGE / WEATHER          SENSOR INSTALLATION          DETAIL</b>	STANDARD PLAN <b>MVLI-541-0</b>
	APPROVED:  1/29/14 PUBLIC WORKS DIRECTOR / DATE CITY ENGINEER		SHEET 1 OF 1

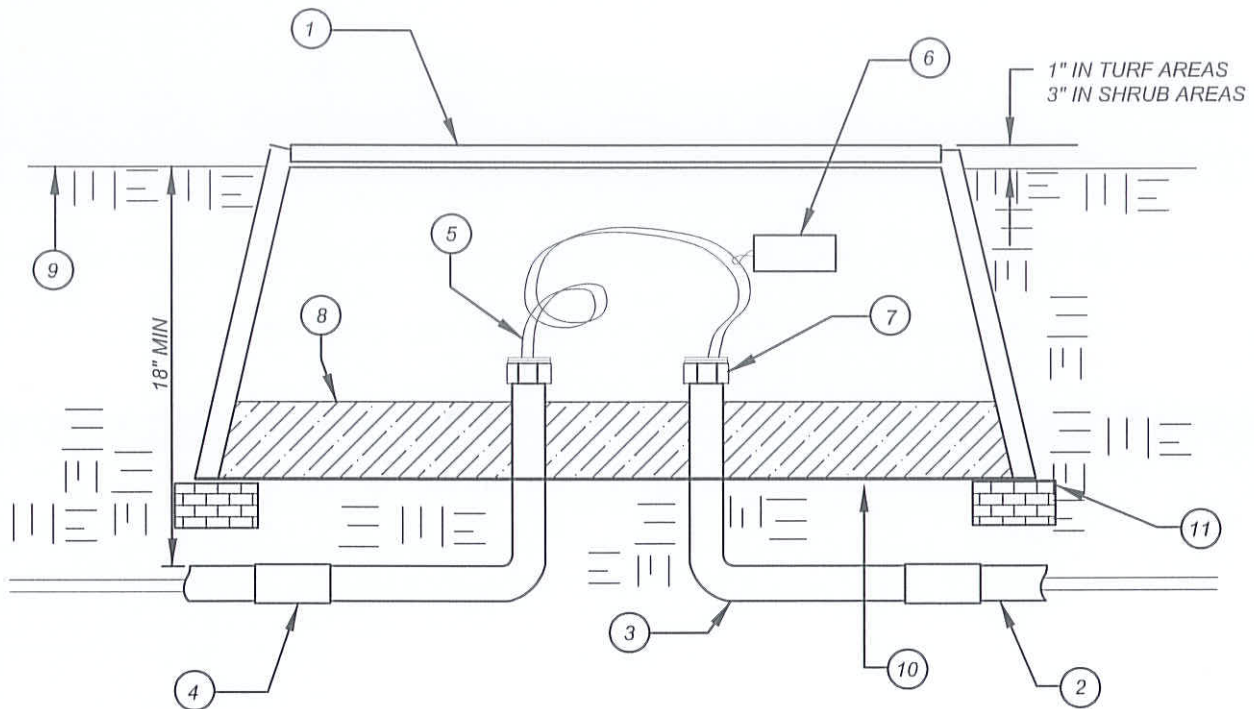

**LEGEND:**

- ① STANDARD RECTANGULAR VALVE BOX (PER PLAN AS SPECIFIED)  
INSTALL @ INTERVALS NOT TO EXCEED 200 FT.
- ② PVC SCH 40 CONDUIT - 1 1/2" NOM OD
- ③ PVC SCH 40, 90 DEG SWEEP ELL (TYP)
- ④ PVC SCH 40, SxS COUPLER (TYP)
- ⑤ POLY PULL ROPE - 500 LB TEST  
- INSTALL PULL ROPE ALONG WITH COMMUNICATION CABLE  
- LEAVE 2 FT LOOP IN BOX
- ⑥ COMMUNICATION CABLE W/ PERMANENT ID TAG (CHRISTY'S OR EQUAL)  
- LEAVE 18" MINIMUM LOOP IN BOX  
- COMMUNICATION CABLE TO BE "PE 39"
- ⑦ CONDUIT BUSHING - INSTALL ON PVC SCH 40 MALE ADAPTER  
- SEAL ALL CONDUIT ENDS W/ WATER PROOF SILICONE  
- SEALER AFTER CABLE/PULL ROPE IS INSTALLED
- ⑧ 3/4" WASHED CRUSHED AGGREGATE - 6" DEPTH
- ⑨ FINISH GRADE
- ⑩ 1/4" GALVANIZED WIRE MESH
- ⑪ CONCRETE BRICK, TYPICAL OF 4

NOT TO SCALE

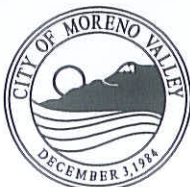

RECOMMENDED:  
*COS* 1/16/14  
 DIVISION MANAGER DATE  
 APPROVED:  
*[Signature]* 1/29/14  
 PUBLIC WORKS DIRECTOR DATE  
 CITY ENGINEER

**CITY OF MORENO VALLEY**  
 FINANCIAL & MANAGEMENT SERVICES DEPARTMENT - SPECIAL DISTRICTS DIVISION

**TELEMETRY PULL-BOX  
 ASSEMBLY DETAIL**

STANDARD PLAN  
**MVLI-542A-0**  
 SHEET 1 OF 2

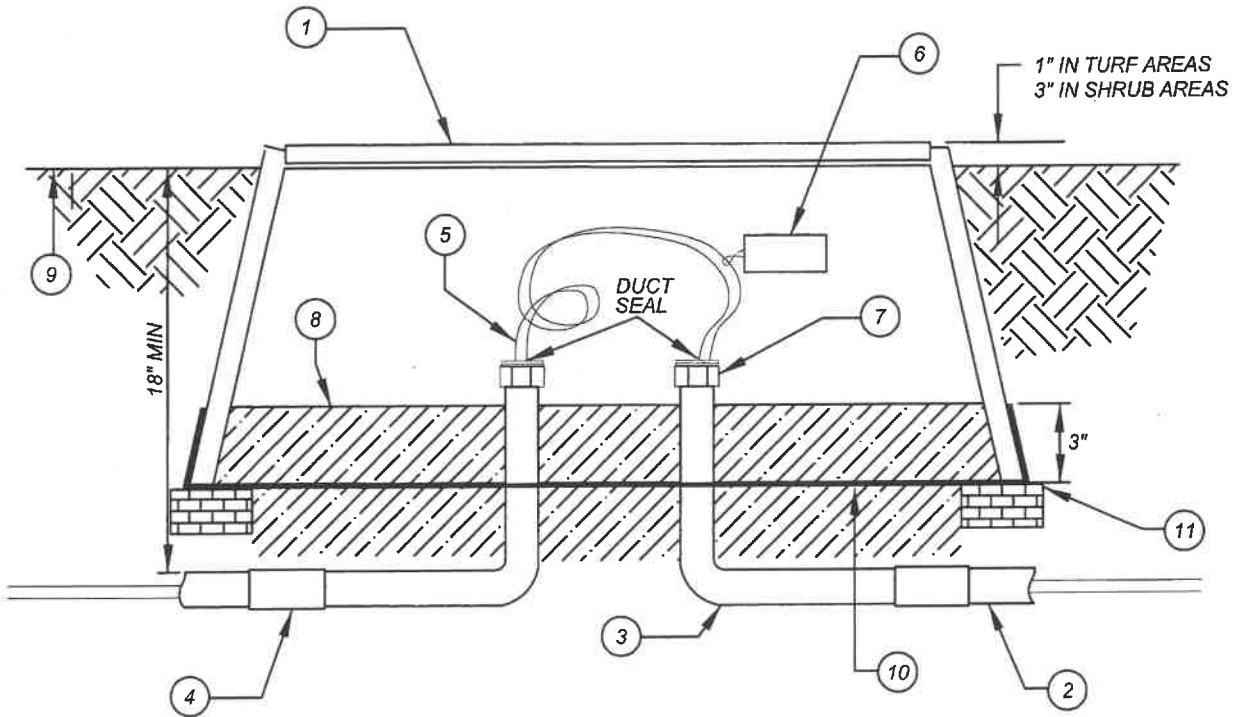

**LEGEND:**

- ① STANDARD RECTANGULAR VALVE BOX (SPECIFIED)  
INSTALL @ INTERVALS NOT TO EXCEED 200 FT
- ② PVC SCH 40 CONDUIT - 1 1/2" NOM OD
- ③ PVC SCH 40, 90 DEG SWEEP ELL (TYP)
- ④ PVC SCH 40, SxS COUPLER (TYP)
- ⑤ POLY PULL ROPE - 500 LB TEST  
-INSTALL PULL ROPE ALONG WITH COMMUNICATION CABLE  
- LEAVE 2 FT LOOP IN BOX
- ⑥ COMMUNICATION CABLE W/ PERMANENT ID TAG (CHRISTY'S OR EQUAL)  
- LEAVE 18" MINIMUM LOOP IN BOX  
- COMMUNICATION CABLE TO BE "PE 39"
- ⑦ CONDUIT BUSHING - INSTALL ON PVC SCH 40 MALE ADAPTER  
- SEAL ALL CONDUIT ENDS W/ WATER PROOF SILICONE  
- SEALER AFTER CABLE/PULL ROPE IS INSTALLED
- ⑧ 3/4" WASHED CRUSHED AGGREGATE - 6" DEPTH
- ⑨ FINISH GRADE
- ⑩ 1/4" STAINLESS STEEL WIRE MESH, TYPE 316
- ⑪ CONCRETE BRICK, TYPICAL OF 4

NOT TO SCALE

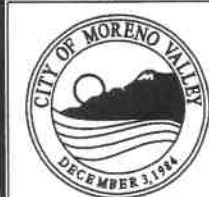

RECOMMENDED:  
  
 DIVISION MANAGER  
 DATE: 6/20/19

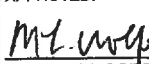
APPROVED:  
  
 PUBLIC WORKS DIRECTOR / DATE  
 CITY ENGINEER 7/30/19

**CITY OF MORENO VALLEY**  
 PARKS AND COMMUNITY SERVICES DEPARTMENT

**TELEMETRY PULL-BOX  
 ASSEMBLY DETAIL**

STANDARD PLAN  
**MVLI-542B-0**  
 SHEET 2 OF 2



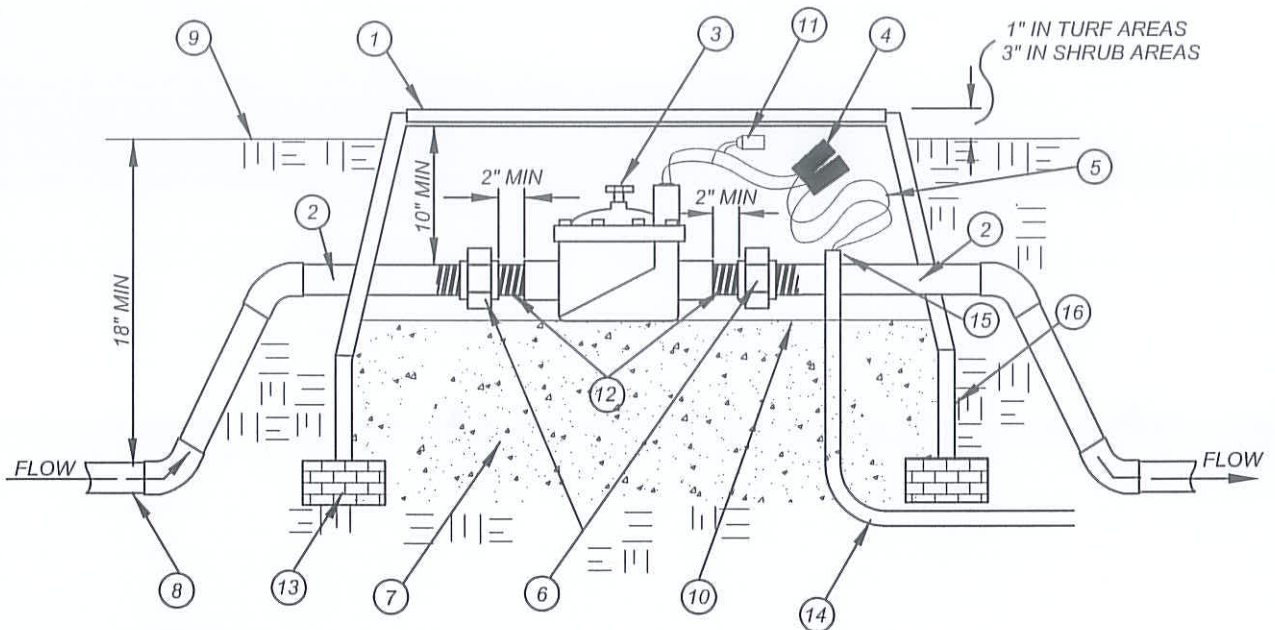

**LEGEND:**

- ① JUMBO RECTANGULAR PLASTIC VALVE BOX WITH LOCKING LID (PER PLAN AS SPECIFIED)
- ② SCH 80 TOE NIPPLE ASSEMBLY - USE IN PLACE OF MIPT ADAPTERS (TYP) (REFER TO STD MVLI-544A-0)
- ③ MASTER CONTROL VALVE (PER PLAN AS SPECIFIED)
- ④ WATERPROOF CONNECTION - SPEARS DS-100 OR APPROVED EQUAL. FILL W/ DS-300 SEALANT OR APPROVED EQUAL (REFER TO STANDARD MVLI-545A-0)
- ⑤ PROVIDE 24" MIN EXPANSION LOOP
- ⑥ SCH 80 PVC UNION (FIPT X FIPT)
- ⑦ 3/4" WASHED CRUSHED AGGREGATE - 6" DEPTH
- ⑧ MAINLINE FROM POC/BACKFLOW PREVENTER ASSEMBLY
- ⑨ FINISH GRADE
- ⑩ 1/4" GALVANIZED WIRE MESH SCREEN
- ⑪ CHRISTY ID TAG WITH CONTROLLER NUMBER
- ⑫ SCH 80 CLOSE NIPPLE
- ⑬ CONCRETE BRICK TYP OF 4
- ⑭ 3/4" ELEC CONDUIT TO FLOW SENSOR AND/OR IRRIGATION CONTROLLER
- ⑮ PLUMBERS PUTTY IN HOLE
- ⑯ VALVE BOX EXTENSION (AS NECESSARY)

**NOTES:**

- 1) INSTALL MASTER VALVE MINIMUM 3 FT DOWNSTREAM OF POC / BACKFLOW ASSEMBLY.
- 2) INSTALL MASTER VALVE MINIMUM 12" FROM STRUCTURES / HARDSCAPE.
- 3) INSTALL THRUST BLOCKS OR BRACE PER SPECIFICATIONS.

NOT TO SCALE

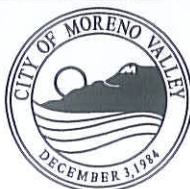

RECOMMENDED:  
*COS* 1.16.14  
 DIVISION MANAGER DATE  
 APPROVED:  
*[Signature]* 1/29/14  
 PUBLIC WORKS DIRECTOR / CITY ENGINEER DATE

**CITY OF MORENO VALLEY**  
 FINANCIAL & MANAGEMENT SERVICES DEPARTMENT - SPECIAL DISTRICTS DIVISION

**MASTER VALVE ASSEMBLY  
 DETAIL**

STANDARD PLAN  
**MVLI-543A-0**  
 SHEET 1 OF 3

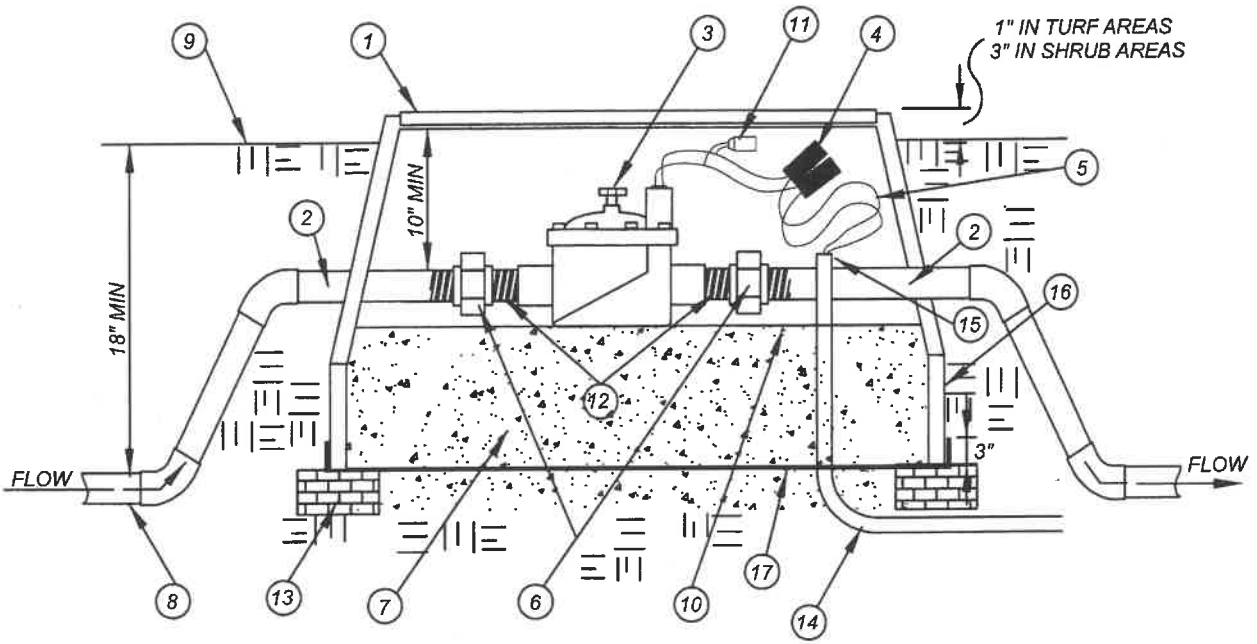

**LEGEND:**

- ① JUMBO RECTANGULAR PLASTIC VALVE BOX WITH LOCKING LID (PER PLAN AS SPECIFIED)
- ② SCH 80 TOE NIPPLE ASSEMBLY - USE IN PLACE OF MIPT ADAPTERS (TYP) (REFER TO STD MVLI-544B-0)
- ③ MASTER CONTROL VALVE (PER PLAN AS SPECIFIED)
- ④ WATERPROOF CONNECTION (PER SPECIFICATIONS)
- ⑤ PROVIDE 24" MIN EXPANSION LOOP
- ⑥ SCH 80 PVC UNION (FIPT x FIPT)
- ⑦ 3/4" WASHED CRUSHED AGGREGATE - 6" DEPTH
- ⑧ MAINLINE FROM POC/BACKFLOW PREVENTER ASSEMBLY
- ⑨ FINISH GRADE
- ⑩ 1/4" STAINLESS STEEL MESH SCREEN, TYPE 316
- ⑪ CHRISTY ID TAG WITH CONTROLLER NUMBER
- ⑫ SCH 80 CLOSE NIPPLE
- ⑬ CONCRETE BRICK TYP OF 4
- ⑭ 3/4" ELEC CONDUIT TO FLOW SENSOR AND/OR IRRIGATION CONTROLLER
- ⑮ DUCT SEAL
- ⑯ VALVE BOX EXTENSION (AS NECESSARY)
- ⑰ 1/4" GALVANIZED WIRE MESH

**NOTES:**

- 1) INSTALL MASTER VALVE MINIMUM 3 FT DOWNSTREAM OF POC / BACKFLOW ASSEMBLY.
- 2) INSTALL MASTER VALVE MINIMUM 12" FROM STRUCTURES / HARDSCAPE.
- 3.) INSTALL THRUST BLOCKS OR BRACE PER SPECIFICATIONS.
- 4.) EPOXY COATED DUCTILE IRON FITTINGS REQUIRED ON MAINLINE 4" AND LARGER.

NOT TO SCALE

	RECOMMENDED:  DIVISION MANAGER	6/20/19 DATE	<b>CITY OF MORENO VALLEY</b> PARKS AND COMMUNITY SERVICES DEPARTMENT
	APPROVED:  PUBLIC WORKS DIRECTOR / CITY ENGINEER	7/30/19 DATE	<b>MASTER VALVE ASSEMBLY          DETAIL</b>

PIPE SIZING CHART		
F.M. SIZE	UPSTREAM LENGTH	DOWNSTREAM LENGTH
1"	10"	5"
1.25"	12.5"	6.25"
1.5"	15"	7.5"
2"	20"	10"
3"	30"	15"

ALL MODELS OF CALSENSE CONTROLLERS

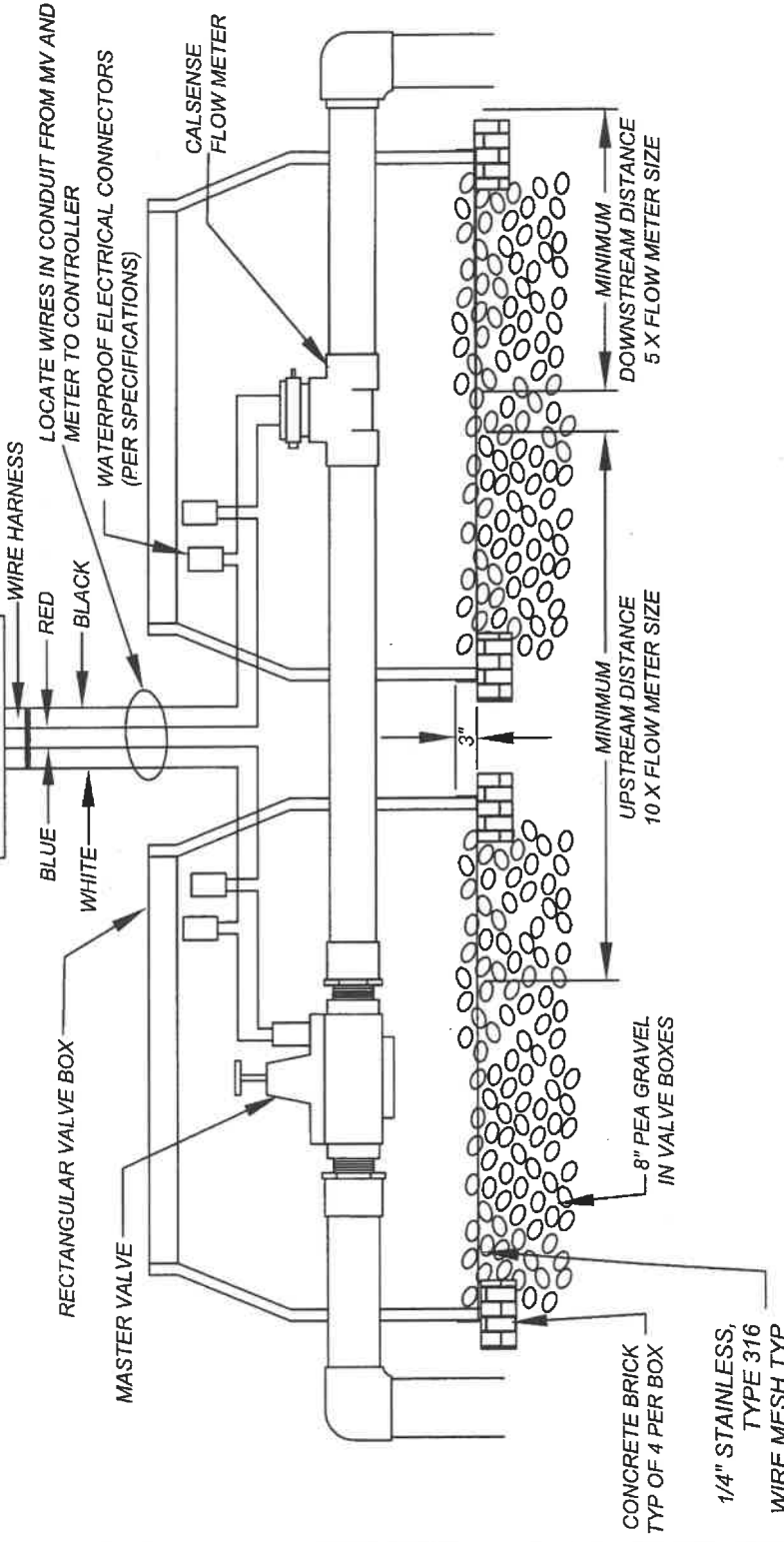

**NOTES:**

1. FOR USE ON PARKS AND COMMUNITY SERVICES PROJECTS.
2. REQUIRES INSPECTION FROM CALSENSE AND PARKS AND COMMUNITY SERVICES.

NOT TO SCALE

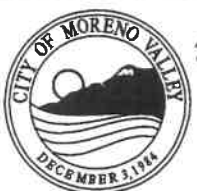

RECOMMENDED: *[Signature]* 6/20/19  
 DIVISION MANAGER DATE  
 APPROVED: *[Signature]* 7/30/19  
 PUBLIC WORKS DIRECTOR / DATE  
 CITY ENGINEER

**CITY OF MORENO VALLEY**  
 PARKS AND COMMUNITY SERVICES DEPARTMENT

**MASTER VALVE AND FLOW METER INSTALLATION**

STANDARD PLAN  
**MVLI-543C-0**  
 SHEET 3 OF 3

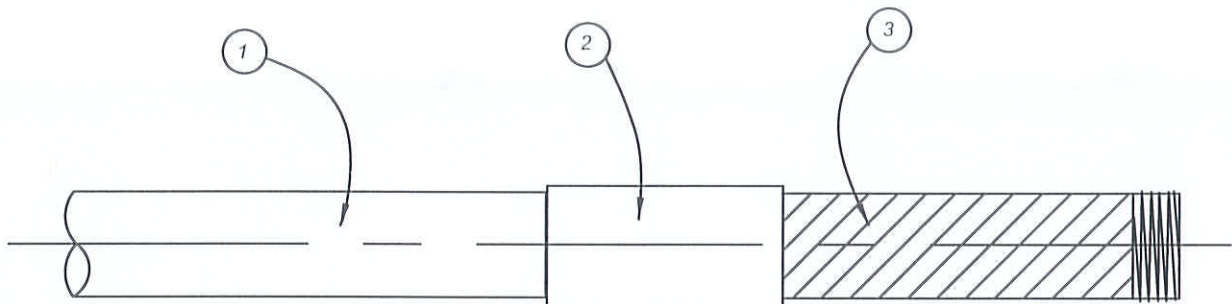

**LEGEND:**

- ① PVC MAIN / LATERAL LINE PIPE
- ② SCH 80 PVC COUPLING SLIP x SLIP
- ③ SCH 80 PVC NIPPLE - THREADED ONE END
  - 6" MIN LENGTH
  - CUT THREADS ONLY - NO MOLDED NIPPLES

**NOTES:**

1) USE TOE NIPPLE ASSEMBLY IN PLACE OF MIPT ADAPTERS

NOT TO SCALE

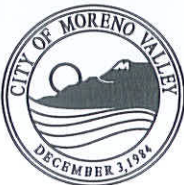
	RECOMMENDED: <div style="display: flex; justify-content: space-between;"> <span><i>COS</i></span> <span>1.16.14</span> </div> <small>DIVISION MANAGER      DATE</small>	<h2 style="margin: 0;">CITY OF MORENO VALLEY</h2> <p style="margin: 0;">FINANCIAL &amp; MANAGEMENT SERVICES DEPARTMENT - SPECIAL DISTRICTS DIVISION</p>	<small>STANDARD PLAN</small> <b>MVLI-544A-0</b>
	APPROVED: <div style="display: flex; justify-content: space-between;"> <span><i>[Signature]</i></span> <span>1/29/14</span> </div> <small>PUBLIC WORKS DIRECTOR/      DATE</small> <small>CITY ENGINEER</small>	<h3 style="margin: 0;">TOE NIPPLE ASSEMBLY</h3>	<small>SHEET 1 OF 2</small>



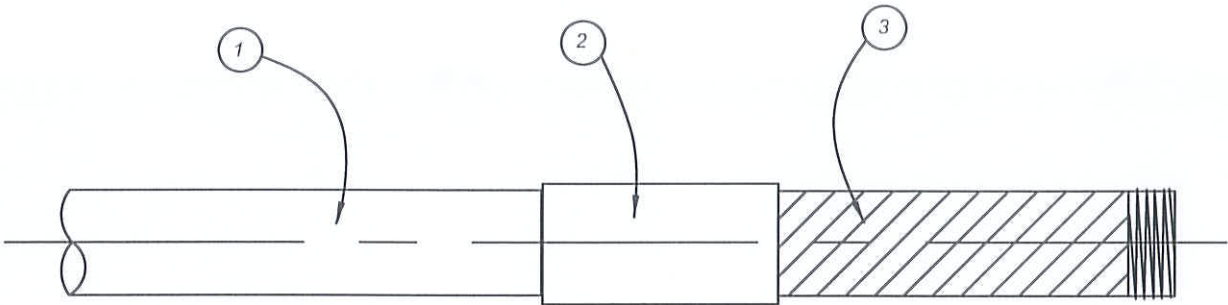

**LEGEND:**

- ① PVC MAIN / LATERAL LINE PIPE
- ② SCH 80 PVC COUPLING SLIP x SLIP
- ③ SCH 80 PVC NIPPLE - THREADED ONE END
  - 6" MIN LENGTH
  - CUT THREADS ONLY - NO MOLDED NIPPLES

**NOTES:**

- 1.) USE TOE NIPPLE ASSEMBLY IN PLACE OF MIPT ADAPTERS.
- 2.) 4" PIPE AND LARGER REQUIRES EPOXY COATED DUCTILE IRON FITTINGS.

NOT TO SCALE

	RECOMMENDED:  DIVISION MANAGER _____ DATE <u>1/21/14</u>	<h2 style="margin: 0;">CITY OF MORENO VALLEY</h2> <p style="margin: 0;">PARKS AND COMMUNITY SERVICES DEPARTMENT</p>		
	APPROVED:  PUBLIC WORKS DIRECTOR / DATE <u>1/29/14</u> CITY ENGINEER _____	<h3 style="margin: 0;">TOE NIPPLE ASSEMBLY</h3>		STANDARD PLAN <h3 style="margin: 0;">MVLI-544B-0</h3>
			SHEET 2 OF 2	

**STEP 1**

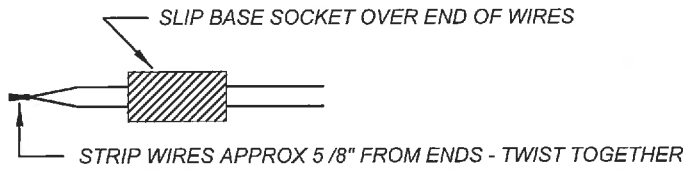

**STEP 2**

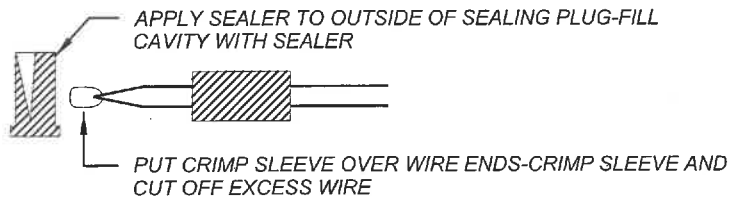

**STEP 3**

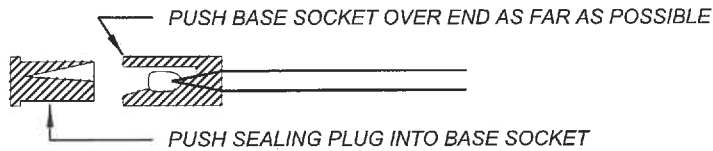

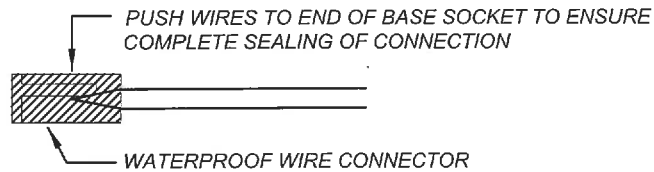

**STEP 4**



**NOTES:**

- 1.) DO NOT USE PREFILLED CONNECTORS ON FLOW SENSORS OR MASTER VALVES.
- 2.) CONNECTORS SHALL BE 600V RATED.

NOT TO SCALE

	RECOMMENDED:  7/22/19 DIVISION MANAGER / DATE	<b>CITY OF MORENO VALLEY</b> PUBLIC WORKS DEPARTMENT - SPECIAL DISTRICTS DIVISION	STANDARD PLAN
	APPROVED:  7/31/19 PUBLIC WORKS DIRECTOR / DATE CITY ENGINEER		<b>IRRIGATION WIRE CONNECTOR</b>
			SHEET 1 OF 3

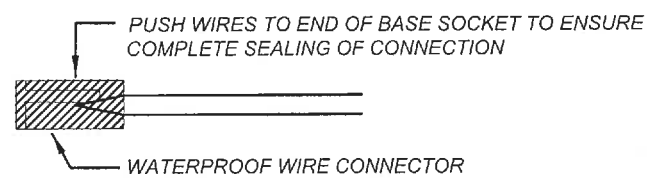
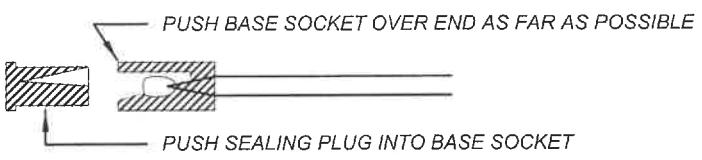
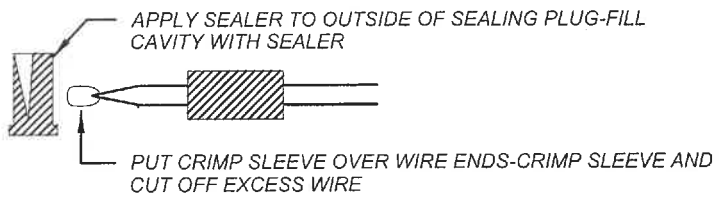
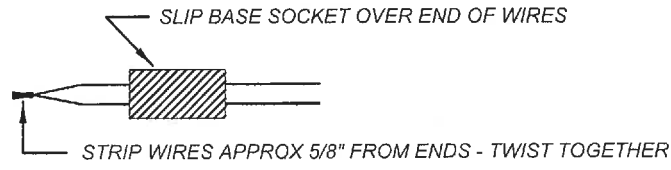

**INSTALLATION INSTRUCTIONS:**

- 1.) TURN OFF POWER BEFORE INSTALLING OR REMOVING CONNECTOR
- 2.) STRIP WIRES 5/8"
- 3.) PRE-TWISTING UNNECESSARY. HOLD STRIPPED WIRES TOGETHER WITH ENDS EVEN. LEAD STRANDED WIRES SLIGHTLY. ALIGN ANY FRAYED STRANDS OR CONDUCTORS
- 4.) FIRMLY PUSH WIRES INTO TWIST-ON CONNECTOR AND SCREW CONNECTOR CLOCKWISE ONTO WIRE UNTIL TIGHT
- 5.) INSERT THE SPLICE TO THE BOTTOM OF THE SEALANT FILLED TUBE
- 6.) POSITION WIRES INTO WIRE CHANNELS AND WIPE ANY SEALANT AROUND OPENING AND CONDUCTORS
- 7.) CLOSE LID ENSURING LATCH IS SECURED

**NOTES:**

- 1.) CONNECTORS SHALL BE 600V RATED.
- 2.) PREFILLED CONNECTORS ARE PREFILLED RAINBIRD OR RAINBIRD DBRY20\*.

\* DO NOT USE PRE-FILLED CONNECTORS ON FLOW SENSORS, TIP BUCKET, WIND GAUGE, OR MASTER VALVE

NOT TO SCALE

	RECOMMENDED:  DIVISION MANAGER	 DATE	<h2 style="margin: 0;">CITY OF MORENO VALLEY</h2> <p style="margin: 0;">PARKS AND COMMUNITY SERVICES DEPARTMENT</p>	
	APPROVED:  PUBLIC WORKS DIRECTOR / CITY ENGINEER	 DATE	<h3 style="margin: 0;">IRRIGATION WIRE CONNECTOR</h3>	STANDARD PLAN <h3 style="margin: 0;">MVLI-545B-0</h3>
	SHEET 2 OF 3			

**IRRIGATION CONTROL WIRE NOTES:**

U.F. TYPE, U.L. APPROVED, AWG MINIMUM NUMBER 12 SOLID STRAND COPPER WIRE WITH MINIMUM 4/64" PVC COATING, 600 VOLT, 75 C., SUITABLE FOR DIRECT BURIAL. 'COMMON' WIRE TO BE WHITE COATED, U.F. TYPE, U.L. APPROVED, AWG NUMBER 12 SOLID STRAND COPPER WIRE WITH MINIMUM 4/64" PVC COATING, 600 VOLT, 75 C., SUITABLE FOR DIRECT BURIAL. WHERE WIRE RUNS EXCEED 1000' FEET, THE 'COMMON' WIRE SHALL BE AWG NUMBER 10 SOLID STRAND COPPER WIRE WITH MINIMUM 4/64" PVC COATING, 600 VOLT, 75 C., SUITABLE FOR DIRECT BURIAL. AN EXTRA CONTROL WIRE (MINIMUM OF ONE) SHALL BE INSTALLED FOR EVERY SIX (6) REMOTE CONTROL VALVES TO THE END OF THE MAINLINE. ONE EXTRA (1) COMMON WIRE (GREEN) SHALL BE RUN FROM EACH CONTROLLER(S) TO THE END OF THE MAINLINE. EACH EXTRA WIRE SHALL BE FROM THE CONTROLLER(S), EXTENDING TO THE LAST VALVE OR END OF MAINLINE AND LOOPED INTO EACH VALVE BOX.





EACH MASTER VALVES, FLOW METER, ET GAUGE, TIPPING BUCKET AND WIND SENSOR SHALL HAVE WIRING ENCASED IN CONDUIT, FROM THE CONTROLLER TO THE VALVE OR METER. THE IRRIGATION WIRE IS TO BE LOCATED DIRECTLY TO THE SIDE OF THE MAINLINE AND TAPED AT INTERVALS OF 8'. WHERE ADDITIONAL (FUTURE) WIRE QUANTITIES ON THE PLAN CONFLICT WITH THESE SPECIFICATIONS, THE GREATER AMOUNT WILL PREVAIL. WIRE COLORS SHALL BE AS LISTED BELOW:

**CONTROLLER 'A', 'B', AND 'C':**

- a. 'A' PILOT = BLACK
- b. 'B' PILOT = GREEN
- c. 'C' PILOT = RED
- d. 'A' COMMON = WHITE WITH BLACK STRIPE
- e. 'B' COMMON = WHITE WITH GREEN STRIPE
- f. 'C' COMMON = WHITE WITH RED STRIPE
- g. 'A' PILOT SPARE = BLACK WITH YELLOW STRIPE
- h. 'B' PILOT SPARE = GREEN WITH YELLOW STRIPE
- i. 'C' PILOT SPARE = RED WITH YELLOW STRIPE
- j. 'A' COMMON SPARE = ORANGE WITH BLACK STRIPE
- k. 'B' COMMON SPARE = ORANGE WITH GREEN STRIPE
- l. 'C' COMMON SPARE = ORANGE WITH RED STRIPE

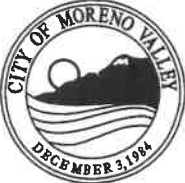
MASTER VALVE #1 = PURPLE  
 MASTER VALVE #2 = GRAY  
 FLOW SENSOR #1 = BLUE  
 FLOW SENSOR #2 = PINK  
 FERTILIZER INJECTOR = TAN  
 PUMP RELAY = YELLOW

NOT TO SCALE

	RECOMMENDED:  DIVISION MANAGER	 DATE	<h2 style="margin: 0;">CITY OF MORENO VALLEY</h2> <p style="margin: 0;">PARKS AND COMMUNITY SERVICES DEPARTMENT</p>
	APPROVED:  PUBLIC WORKS DIRECTOR / CITY ENGINEER	 DATE	<h3 style="margin: 0;">IRRIGATION CONTROL WIRE NOTES</h3>



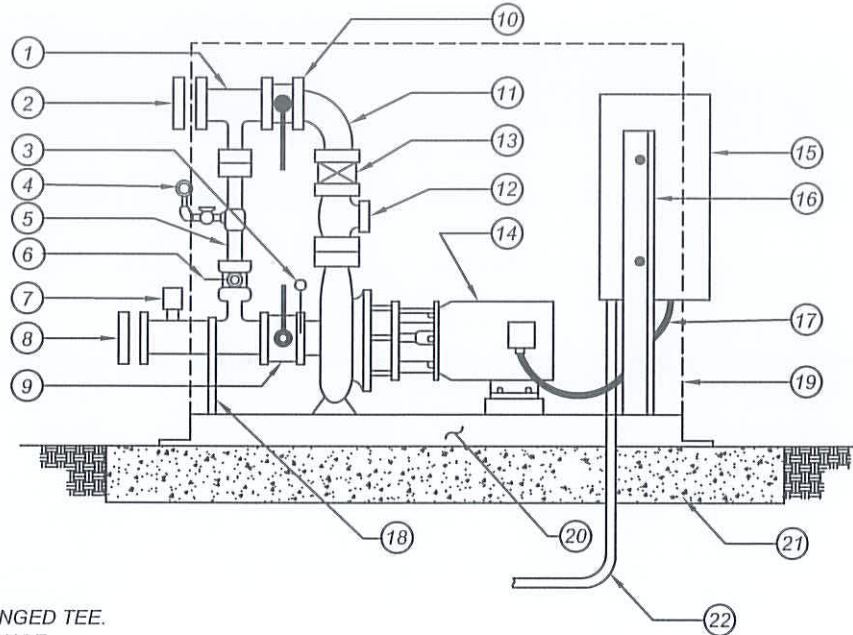



**LEGEND:**

- ① DISCHARGE FLANGED TEE.
- ② COMPANION FLANGE.
- ③ PRESSURE GAUGE.
- ④ PRESSURE GAUGE.
- ⑤ BYPASS - 2" DIA MIN.
- ⑥ BUTTERFLY VALVE
- ⑦ FLOW SWITCH TO BE INSTALLED IN SECTION HEADER WIRED TO PUMP PANEL.
- ⑧ COMPANION FLANGE.
- ⑨ BUTTERFLY VALVE.
- ⑩ BUTTERFLY VALVE.
- ⑪ FLANGED 90 COMBINATION PRESSURE REGULATING AND NON-SLAM CHECK VALVE.
- ⑫ BAILEY No 400 ACP OR CLA-VAL No 91A.
- ⑬ FLANGED CONCENTRIC REDUCER.
- ⑭ PUMP AND MOTOR.
- ⑮ CONTROLLER ( 3 PHASE, 230 VOLT )
- ⑯ CONTROLLER SUPPORT.
- ⑰ SEALTITE CONDUIT
- ⑱ SUPPORT LEG.
- ⑲ 36" x 42" x 20" SHEET METAL ENCLOSURE FOR EXTERIOR PUMP INSTALLATION.
- ⑳ GALVANIZED STEEL SKID, WITH 4 9/16" HOLES.
- ㉑ PRE-CAST CONCRETE PAD BY MFG.
- ㉒ RIGID STEEL CONDUIT TO POWER SOURCE

**NOTES:**

- 1) ENCLOSURE IS REQUIRED SUBJECT TO CITY APPROVAL.
- 2) CONTRACTOR TO VERIFY AVAILABLE VOLTAGE COMPATIBLE WITH MOTOR SPECIFICATIONS.

NOT TO SCALE

	RECOMMENDED: <i>CO5</i> 1.16.14 DIVISION MANAGER      DATE	<h2 style="margin: 0;">CITY OF MORENO VALLEY</h2> <p style="margin: 0;">FINANCIAL &amp; MANAGEMENT SERVICES DEPARTMENT - SPECIAL DISTRICTS DIVISION</p>	STANDARD PLAN <b>MVLI-546-0</b>
	APPROVED:  1/29/14 PUBLIC WORKS DIRECTOR / DATE CITY ENGINEER	<h3 style="margin: 0;">IRRIGATION BOOSTER PUMP DETAIL</h3>	SHEET 1 OF 1

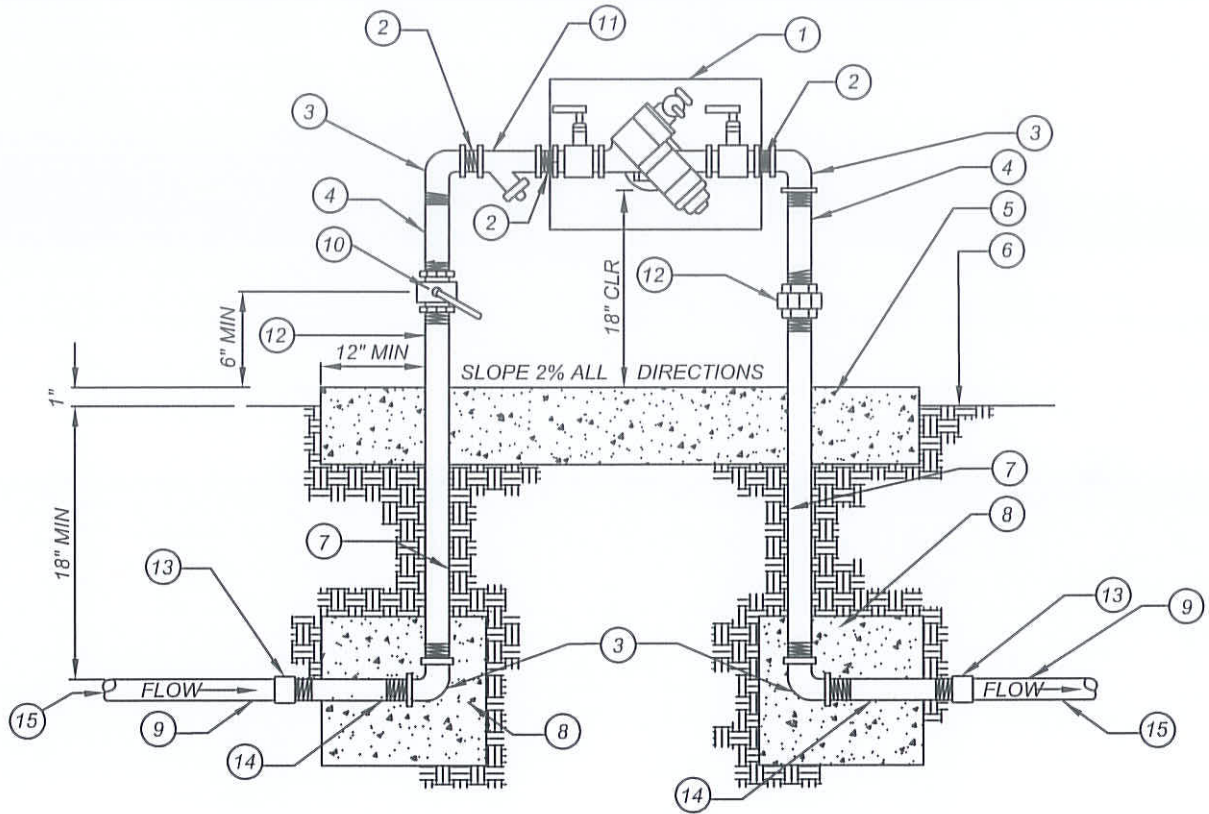

**LEGEND:**

- 1 BACKFLOW PREVENTER ASSEMBLY
- 2 BRASS CLOSE NIPPLE
- 3 BRASS 90 ELL-TYPICAL (4) PLACES
- 4 BRASS NIPPLE
- 5 6" THICK CONCRETE PAD (SEE PAD SCHEDULE)  
SLOPE TO DRAIN AT MINIMUM 2%
- 6 FINISH GRADE
- 7 BRASS NIPPLE
- 8 12" x 12" x 12" CONCRETE THRUST BLOCKS - TYPICAL (2) PLACES
- 9 SCHEDULE 80 TOE NIPPLE ASSEMBLY - TYPICAL (2) PLACES (REFER TO STANDARD MVLI-544A-0)
- 10 LINE SIZED BRASS FULL PORT LOCKING BALL VALVE
- 11 BRASS WYE STRAINER WITH 60 MESH SCREEN AS SPECIFIED
- 12 BRASS UNION (OR PRESSURE REGULATOR WITH UNION IF REQUIRED)
- 13 BRASS COUPLING
- 14 BRASS NIPPLE - LENGTH AS NECESSARY TO EXTEND PAST CONCRETE PAD
- 15 PVC MAIN LINE

**PAD SCHEDULE**

RP DEVICE SIZE	WIDTH	LENGTH
2 1/2"	30"	66"
3"-4"	36"	78"

**NOTES:**

- 1) EQUIPMENT TO BE INSTALLED AT A MINIMUM OF 24" FROM ANY STRUCTURES OR HARDSCAPING.
- 2) WHEN UNIT IS NEXT TO A STRUCTURE (I.E. WALL, BUILDING, ETC.) MOUNT TEST COCKS ON OPEN OR NON-STRUCTURE SIDE.
- 3) REDUCED PRESSURE DEVICE MUST BE SAME SIZE AS WATER METER/SERVICE LINE PER EMWD.
- 4) IF PRESSURE REGULATING VALVE IS REQUIRED, INSTALL ON DOWNSTREAM LEG OF BACKFLOW PREVENTER.

NOT TO SCALE

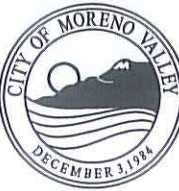
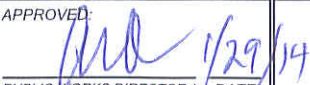
	RECOMMENDED: <i>COS</i> 1-16-14 DIVISION MANAGER DATE	<h2 style="margin: 0;">CITY OF MORENO VALLEY</h2> <p style="margin: 0;">FINANCIAL &amp; MANAGEMENT SERVICES DEPARTMENT - SPECIAL DISTRICTS DIVISION</p>	STANDARD PLAN <b>MVLI-547A-0</b>
	APPROVED:  PUBLIC WORKS DIRECTOR / DATE CITY ENGINEER	<h3 style="margin: 0;">REDUCED PRESSURE BACKFLOW PREVENTER</h3>	SHEET 1 OF 2

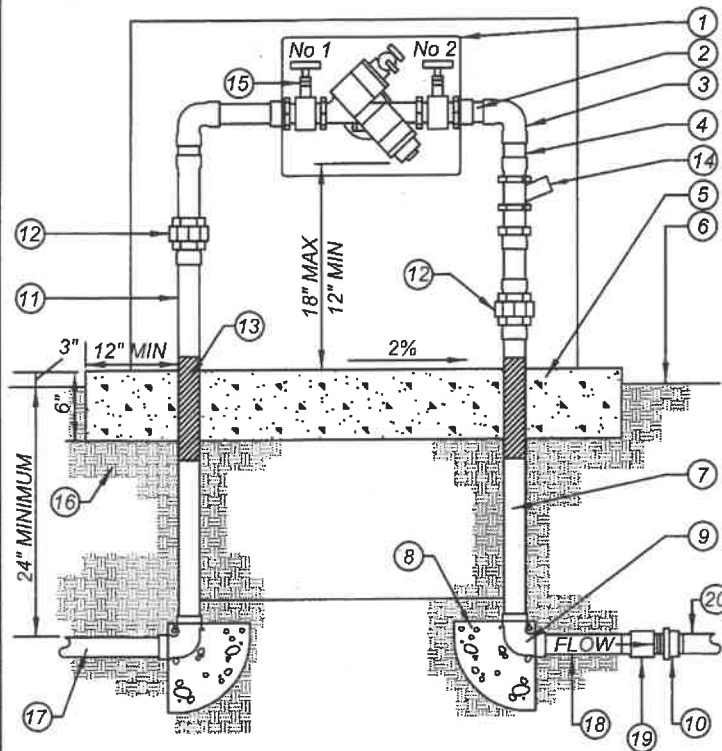

**LEGEND:**

- ① BACKFLOW PREVENTER ASSEMBLY, PRE-ASSEMBLED
- ② BRASS OR TYPE K COPPER NIPPLE-TYPICAL
- ③ BRASS OR TYPE K COPPER 90 ELL-TYPICAL
- ④ BRASS OR TYPE K COPPER NIPPLE
- ⑤ 6" THICK CONCRETE PAD (3250 PSI) SLOPE TO DRAIN AT MINIMUM 2%
- ⑥ FINISH GRADE
- ⑦ BRASS OR TYPE K COPPER NIPPLE
- ⑧ 1 CU FT CONCRETE THRUST BLOCKS - TYPICAL (2) PLACES
- ⑨ BRASS OR TYPE K COPPER 90 ELL
- ⑩ SCHEDULE 80 PVC MALE ADAPTER
- ⑪ FROM WATER SOURCE
- ⑫ BRASS UNION WITH ADAPTERS
- ⑬ 10 MIL POLYETHYLENE TAPE, 1.5 TIMES WRAP
- ⑭ WYE STRAINER PER SPECIFICATION
- ⑮ SHUT OFF VALVE (TYPE VARIES)
- ⑯ 90% COMPACTED SUBGRADE
- ⑰ TYPE K COPPER SERVICE
- ⑱ 8" LONG BRASS OR TYPE K COPPER NIPPLE
- ⑲ BRASS OR TYPE K COPPER FEMALE ADAPTER
- ⑳ TYPE K COPPER (AS REQUIRED) PRESSURE SUPPLY LINE

**NOTES:**

- 1) BACKFLOW PREVENTER ASSEMBLY SHALL BE APPROVED AND TESTED UPON INSTALLATION BY A EMWD APPROVED CERTIFIED BACKFLOW DEVICE TESTER. CONTRACTOR SHALL PROVIDE THE ENGINEER AND CITY WITH WRITTEN RESULTS COMPLETED BY A CERTIFIED BACKFLOW TESTER.
- 2) PRIOR TO BACKFLOW PREVENTER'S ACCEPTANCE BY THE ENGINEER, ALL METAL IN CONTACT WITH CONCRETE SHALL BE POLYETHYLENE WRAPPED USING 2" WIDE PLASTIC BACKED ADHESIVE TAPE MIN. 10 MILS. THICK 1/2" OVERLAP.
- 3) CONCRETE PAD TO BE 2" ABOVE GRADE. CONCRETE PAD SHALL BE 3,250 PSI, 8" THICK, 24" WIDE (MIN), + 3' ON HINGED SIDE.
- 4) FACTORY ASSEMBLED REDUCED PRESSURE PRINCIPLE ASSEMBLY SHALL BE INCLUDED IN THE EDITION OF THE 'APPROVED FOR SERVICE ISOLATION IN CALIFORNIA PUBLIC WATER SYSTEMS' ISSUED BY THE STATE OF CALIFORNIA DEPARTMENT.
- 5) PRESSURE REGULATOR MAY BE INSTALLED UPSTREAM OF THE BACKFLOW PREVENTER ASSEMBLY WHEN WATER PRESSURE EXCEEDS BACKFLOW PREVENTER ASSEMBLY RATING.
- 6) COMBINATION OF WYE STRAINER AND REGULATOR, WHEN REQUIRED, SHALL BE LOCATED UPSTREAM OF BACKFLOW DEVICE.
- 7) PROTECTIVE ENCLOSURE FOR BACKFLOW PREVENTER ASSEMBLY SHALL BE USED SIZE TO FIT.
- 8) LOCATE PREVENTER ASSEMBLY AS APPROVED BY PARKS AND COMMUNITY SERVICES.
- 9) ALL RISERS, ELBOWS AND UNDERGROUND PIPING SHALL BE BRASS OR TYPE 'K' COPPER. BRASS UNIONS ARE ACCEPTABLE. ALL PIPING SHALL BE POLY SLEEVED. EPOXY OR POLLYESTER DIPPED DUCTILE IRON REQUIRED 4" AND LARGER UNITS.
- 10) BACKFLOW DEVICES REQUIRE A FROST GUARD BLANKET.
- 11) PAINT DOMESTIC BACKFLOW - GREEN, IRRIGATION - BLUE, RECLAIMED - PURPLE

**PAD SCHEDULE**

RP DEVICE SIZE	WIDTH	MIN LENGTH
2 1/2"	30"	66"
3"-4"	36"	78"

NOT TO SCALE



RECOMMENDED: *[Signature]* 6/20/19  
 DIVISION MANAGER DATE  
 APPROVED: *[Signature]* 7/30/19  
 PUBLIC WORKS DIRECTOR / DATE  
 CITY ENGINEER

**CITY OF MORENO VALLEY**

PARKS AND COMMUNITY SERVICES DEPARTMENT

**BACK FLOW PREVENTER**

STANDARD PLAN  
**MVLI-547B-1**

SHEET 2 OF 2



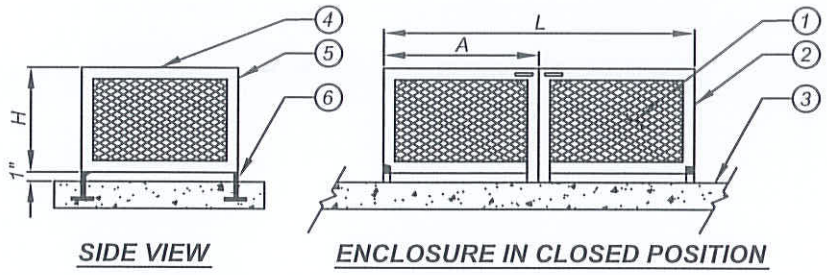
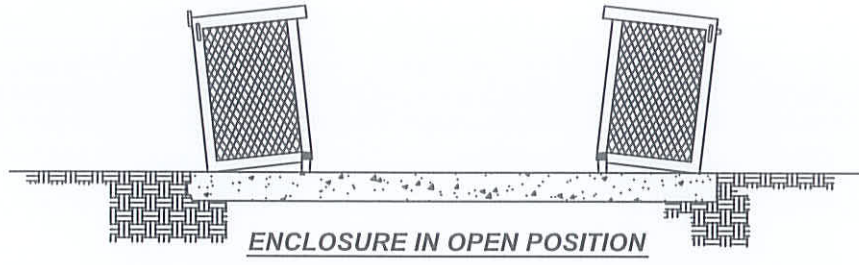

RP DEVICE SIZE	W	L	H	A
2 1/2"	24"	60"	36"	30"
3"-4"	30"	72"	42"	36"

**LEGEND:**

- ① 1 1/2"- No 9 EXPANDED METAL
- ② 1 1/2" x 1 1/2" x 3/16" ANGLE FRAME
- ③ CONCRETE PAD (SEE STANDARD MVLI-547A-0)
- ④ HASP FOR PAD LOCK
- ⑤ LIFTING HANDLE
- ⑥ HINGE PLATE

**NOTES:**

- 1) FINISH TO BE TWO COATS OF SEMI-GLOSS GREEN ENAMEL PAINT, OR AS SPECIFIED ON PLANS.
- 2) FOR UNITS 2" AND UNDER USE SINGLE SWING HINGE MODEL.
- 3) IT IS THE RESPONSIBILITY OF THE CONTRACTOR TO ENSURE THAT THE BACKFLOW PREVENTER ASSEMBLY FITS WITHIN SPECIFIED ENCLOSURE. ANY DISCREPANCY SHALL BE REPORTED TO SPECIAL DISTRICTS IMMEDIATELY.

NOT TO SCALE

	RECOMMENDED: <i>COS</i> 1-16-14 <small>DIVISION MANAGER DATE</small>	<h2 style="margin: 0;">CITY OF MORENO VALLEY</h2> <p style="margin: 0;">FINANCIAL &amp; MANAGEMENT SERVICES DEPARTMENT - SPECIAL DISTRICTS DIVISION</p>	<small>STANDARD PLAN</small> <b>MVLI-548A-0</b>
	APPROVED: <i>[Signature]</i> 1/29/14 <small>PUBLIC WORKS DIRECTOR / DATE</small> <small>CITY ENGINEER</small>	<h3 style="margin: 0;">BACKFLOW PREVENTER ENCLOSURE</h3>	<small>SHEET 1 OF 3</small>



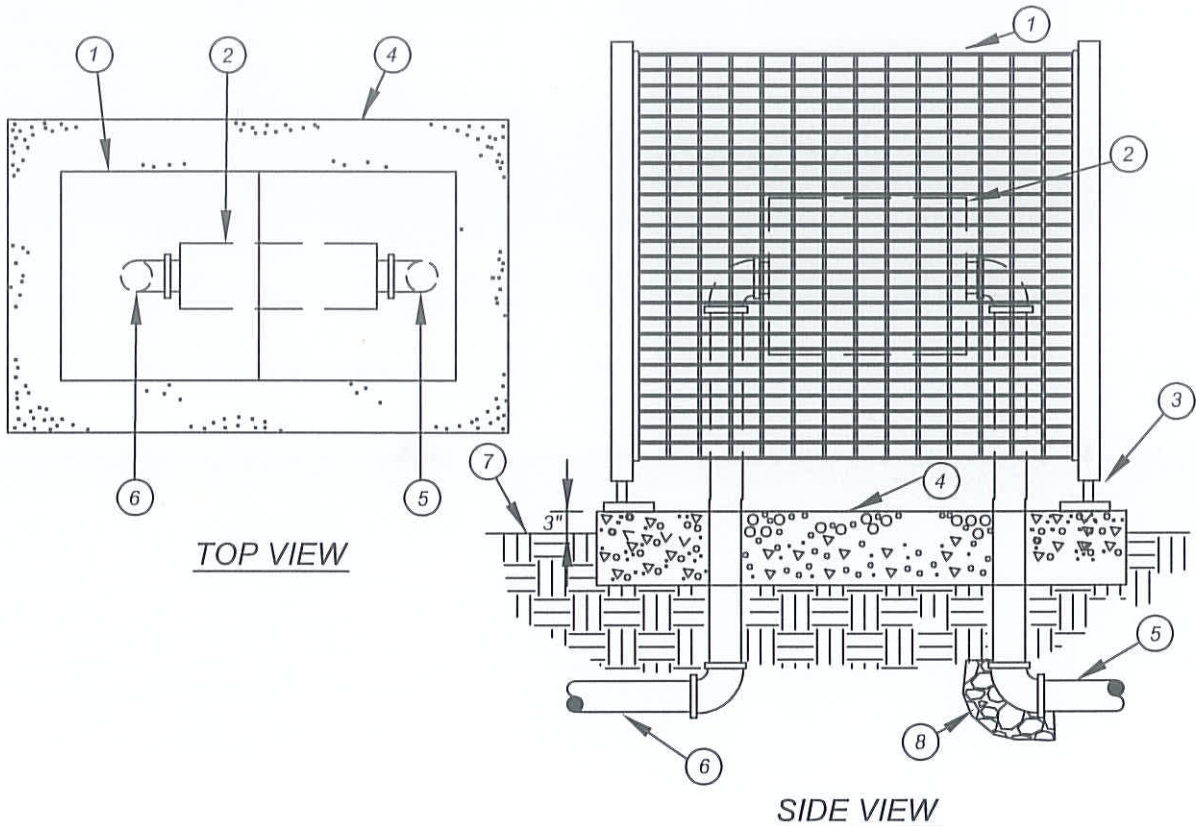



**LEGEND:**

- ① SMOOTH TOUCH STAINLESS STEEL. BACKFLOW COVER WITH VANDAL PROOF LOCKING DEVICE
- ② BACKFLOW PREVENTER
- ③ ANCHOR ROD (TYPICAL)
- ④ 3250 PSI POURED CONCRETE BASE - 9" MINIMUM THICKNESS THAT EXTENDS 6" BEYOND OUTSIDE DIMENSIONS OF ENCLOSURE AND 3' ON THE HINGED SIDE(S) OF THE ENCLOSURE.
- ⑤ WATER SERVICE INLET PIPING
- ⑥ WATER SERVICE OUTLET PIPING
- ⑦ FINISH GRADE
- ⑧ THRUST BLOCK, TYPICAL OF 2

**NOTES:**

1. USE OF EXPANDED METAL REQUIRES SANDBLAST AND POWDERCOATING. (COLOR DETERMINED BY SPECIFICATIONS. MUST BE PRE-APPROVED BY PARKS AND COMMUNITY SERVICES.)
2. UNIT REQUIRES SUBMITTAL AND APPROVAL OF SHOP DRAWINGS.

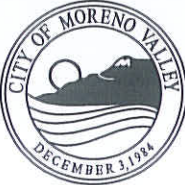
NOT TO SCALE

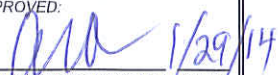
	RECOMMENDED:  1/21/14 DIVISION MANAGER      DATE	<h2 style="margin: 0;">CITY OF MORENO VALLEY</h2> <p style="margin: 0;">PARKS AND COMMUNITY SERVICES DEPARTMENT</p>	STANDARD PLAN <b>MVLI-548B-0</b>
	APPROVED:  1/29/14 PUBLIC WORKS DIRECTOR / DATE CITY ENGINEER	<h3 style="margin: 0;">SINGLE BACKFLOW COVER</h3>	

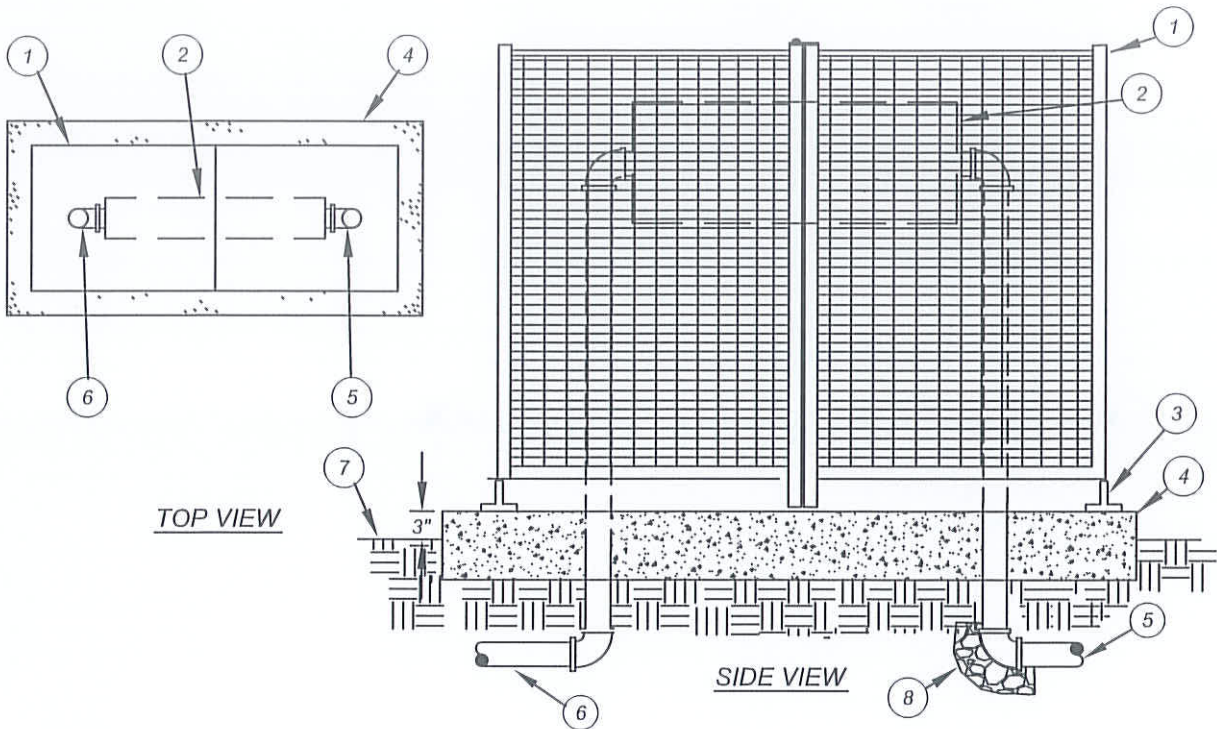

**LEGEND:**

- ① SMOOTH TOUCH STAINLESS STEEL. BACKFLOW COVER WITH VANDAL PROOF LOCKING DEVICE
- ② BACKFLOW PREVENTER
- ③ ANCHOR ROD (TYPICAL)
- ④ 3250 PSI POURED CONCRETE BASE - 12" MINIMUM THICKNESS THAT EXTENDS 6" BEYOND OUTSIDE DIMENSIONS OF ENCLOSURE AND 3' ON THE HINGED SIDES OF THE ENCLOSURE.
- ⑤ WATER SERVICE INLET PIPING
- ⑥ WATER SERVICE OUTLET PIPING
- ⑦ FINISH GRADE
- ⑧ THRUST BLOCK, TYPICAL OF 2

**NOTES:**

1. USE OF EXPANDED METAL REQUIRES SANDBLAST AND POWDERCOATING (COLOR DETERMINED BY SPECIFICATIONS). MUST BE PRE-APPROVED BY PARKS AND COMMUNITY SERVICES.
2. UNIT REQUIRES SUBMITTAL AND APPROVAL OF SHOP DRAWINGS.

NOT TO SCALE

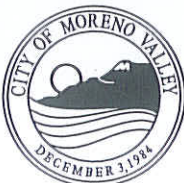

RECOMMENDED:  
  
 DIVISION MANAGER DATE 4/21/14  
 APPROVED:  
  
 PUBLIC WORKS DIRECTOR / DATE 4/29/14  
 CITY ENGINEER

**CITY OF MORENO VALLEY**  
 PARKS AND COMMUNITY SERVICES DEPARTMENT

**DOUBLE BACKFLOW COVER**

STANDARD PLAN  
**MVLI-548C-0**

SHEET 3 OF 3



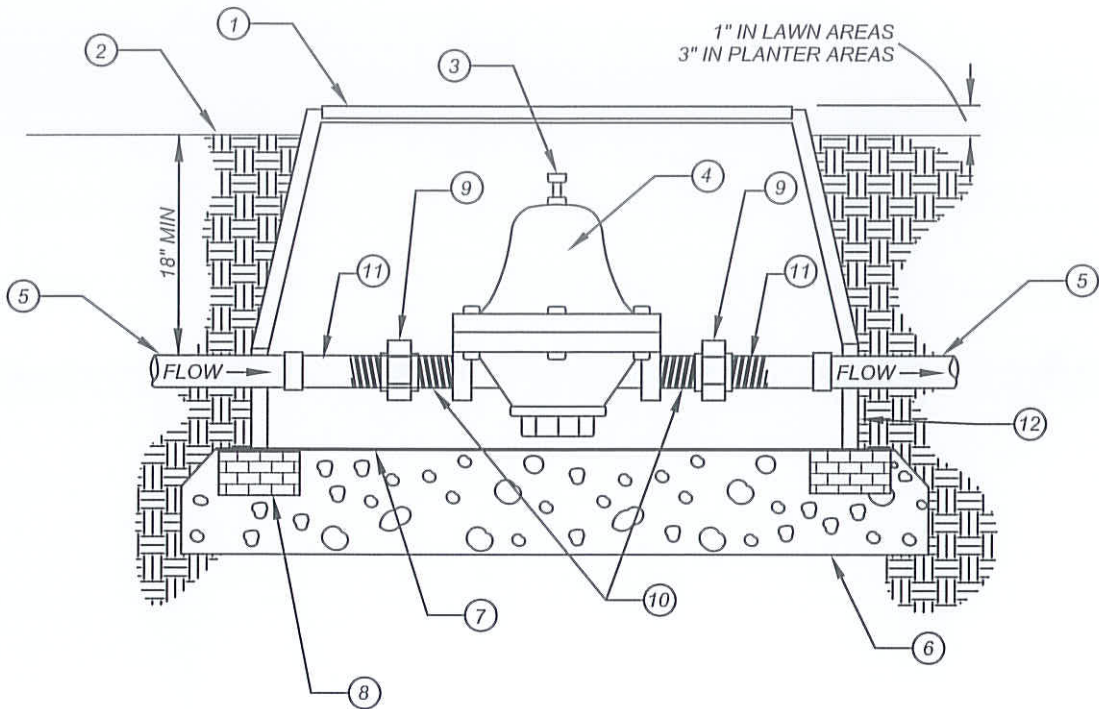



**LEGEND:**

- ① JUMBO RECTANGULAR PLASTIC VALVE BOX WITH LOCKING LID (PER PLAN AS SPECIFIED), "PR" TO BE BRANDED ON LID
- ② FINISH GRADE
- ③ PRESSURE ADJUSTMENT SCREW
- ④ PRESSURE REGULATOR (PER PLAN AS SPECIFIED)
- ⑤ IRRIGATION MAIN-LINE
- ⑥ 3/4" WASHED CRUSHED AGGREGATE BASE
- ⑦ 1/4" GALVANIZED WIRE MESH
- ⑧ CONCRETE BRICK, TYPICAL OF 4
- ⑨ SCH 80 PVC UNION (FIPT x FIPT)
- ⑩ SCH 80 CLOSE NIPPLE
- ⑪ TOE NIPPLE ASSEMBLY (REFER TO STANDARD MVLI-544A-0)
- ⑫ VALVE BOX EXTENSION (AS NECESSARY)

**NOTES:**

- 1) PLACE AGGREGATE PRIOR TO INSTALLATION OF BOX.

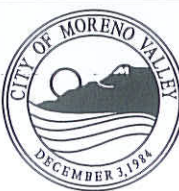
NOT TO SCALE

	RECOMMENDED:  1-16-14 DIVISION MANAGER      DATE	<h2 style="margin: 0;">CITY OF MORENO VALLEY</h2> <p style="margin: 0;">FINANCIAL &amp; MANAGEMENT SERVICES DEPARTMENT - SPECIAL DISTRICTS DIVISION</p>	STANDARD PLAN	
	APPROVED:  1/29/14 PUBLIC WORKS DIRECTOR / DATE CITY ENGINEER	<h2 style="margin: 0;">PRESSURE REDUCING VALVE</h2>		<h3 style="margin: 0;">MVLI-550A-0</h3>
				SHEET 1 OF 2

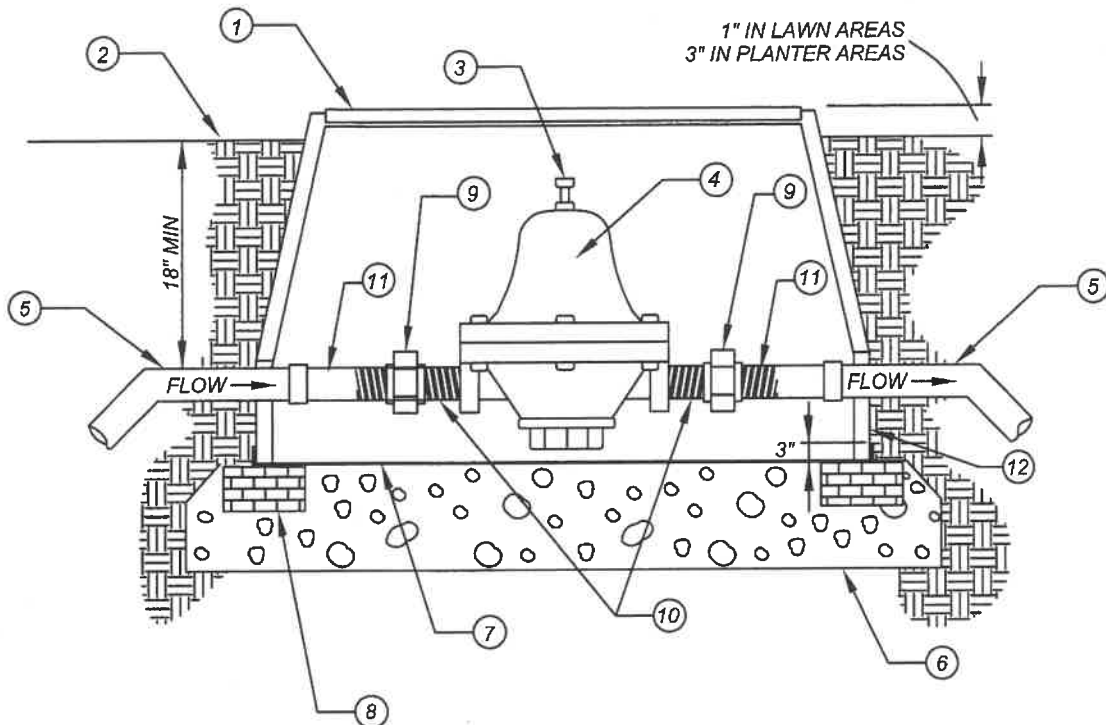





**LEGEND:**

- ① JUMBO RECTANGULAR PLASTIC VALVE BOX WITH LOCKING LID (PER SPECIFICATIONS), "PR" TO BE BRANDED ON LID
- ② FINISH GRADE
- ③ PRESSURE ADJUSTMENT SCREW
- ④ PRESSURE REGULATOR (PER PLAN AS SPECIFIED)
- ⑤ IRRIGATION MAIN-LINE
- ⑥ 3/4" WASHED CRUSHED AGGREGATE BASE
- ⑦ 1/4" STAINLESS STEEL WIRE MESH, TYPE 316
- ⑧ CONCRETE BRICK, TYPICAL OF 4
- ⑨ SCH 80 PVC UNION (FIPT X FIPT)
- ⑩ SCH 80 CLOSE NIPPLE
- ⑪ TOE NIPPLE ASSEMBLY (REFER TO STANDARD MVLI-544B-0)
- ⑫ VALVE BOX EXTENSION (AS NECESSARY)

**NOTES:**

- 1) PLACE AGGREGATE PRIOR TO INSTALLATION OF BOX.
- 2) MAINLINE 4" OR LARGER PIPE REQUIRED EPOXY COATED DUCTILE IRON FITTINGS.

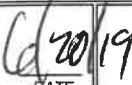
NOT TO SCALE

	RECOMMENDED:  DIVISION MANAGER	 DATE	<b>CITY OF MORENO VALLEY</b> PARKS AND COMMUNITY SERVICES DEPARTMENT
	APPROVED:  PUBLIC WORKS DIRECTOR / CITY ENGINEER	 DATE	<b>PRESSURE REDUCING VALVE</b>



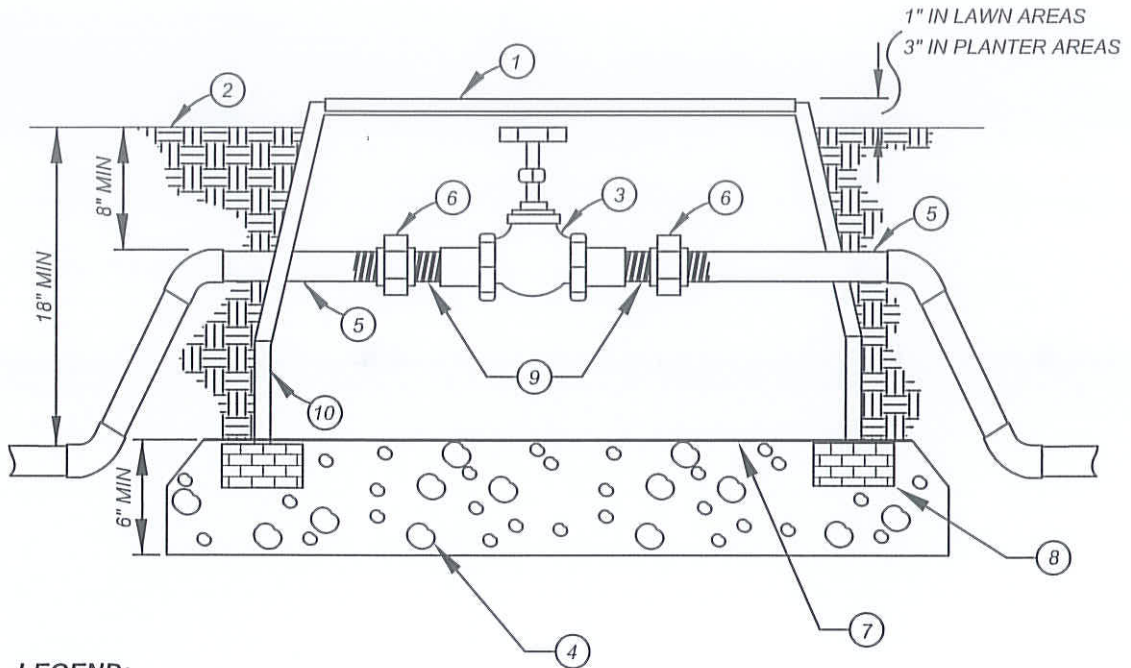

**LEGEND:**

- ① JUMBO RECTANGULAR PLASTIC VALVE BOX WITH LOCKING LID (PER PLAN AS SPECIFIED), COVER SHALL BE MARKED "BV" OR "GV" VIA BRANDING (2")
- ② FINISH GRADE
- ③ LOCKING BALL VALVE OR GATE VALVE (PER PLAN AS SPECIFIED)
- ④ 3/4" WASHED CRUSHED AGGREGATE BASE
- ⑤ SCH 80 PVC TOE NIPPLE ASSEMBLY (REFER TO STANDARD MVLI-544A-0)
- ⑥ SCH 80 PVC UNION, FIPT x FIPT
- ⑦ 1/4" GALVANIZED WIRE MESH
- ⑧ CONCRETE BLOCK, TYPICAL OF 4
- ⑨ SCH 80 CLOSE NIPPLE
- ⑩ VALVE BOX EXTENSION (AS NECESSARY)

**NOTES:**

- 1) PLACE AGGREGATE PRIOR TO INSTALLATION OF VALVE BOX.
- 2) IF BALL VALVES ARE USED, A JUMBO RECTANGULAR BOX SHALL BE INSTALLED. BALL VALVES UNDER 2" TO HAVE HANDLE LOCATED VERTICALLY. BALL VALVES LARGER THAN 2" TO HAVE A 2" SQUARE NUT AND DELETE HANDLE.
- 3) CAST IRON AND / OR FLANGED VALVES WILL REQUIRE A POURED-IN-PLACE CONCRETE SUPPORT (NOT SHOWN).

NOT TO SCALE



RECOMMENDED:  
 DIVISION MANAGER *COX* DATE *1.16.14*  
 APPROVED:  
 PUBLIC WORKS DIRECTOR / DATE *1/29/14*  
 CITY ENGINEER

**CITY OF MORENO VALLEY**  
 FINANCIAL & MANAGEMENT SERVICES DEPARTMENT - SPECIAL DISTRICTS DIVISION

**BALL VALVE / GATE VALVE  
 3" OR SMALLER**

STANDARD PLAN  
**MVLI-551A-0**

SHEET 1 OF 2

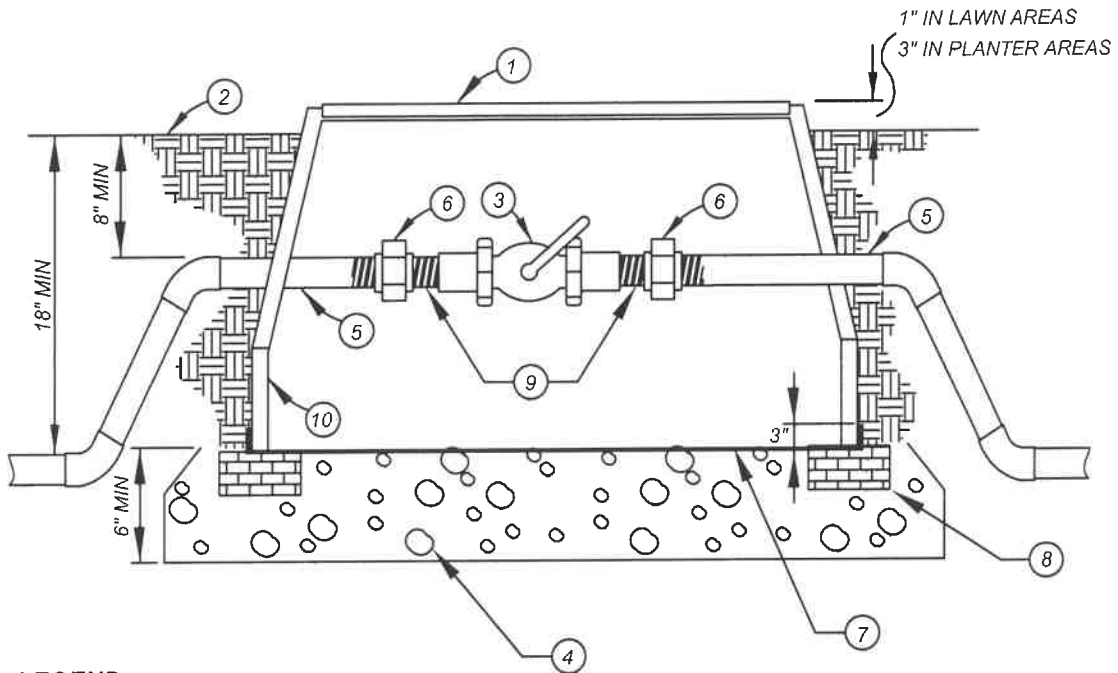



**LEGEND:**

- ① JUMBO RECTANGULAR PLASTIC VALVE BOX WITH LOCKING LID (PER PLAN AS SPECIFIED), COVER SHALL BE MARKED "BV" OR "GV" VIA BRANDING (2")
- ② FINISH GRADE
- ③ BALL VALVE (PER SPECIFICATIONS)
- ④ 3/4" WASHED CRUSHED AGGREGATE BASE
- ⑤ SCH 80 PVC TOE NIPPLE ASSEMBLY (REFER TO STANDARD MVLI-544B-0)
- ⑥ SCH 80 PVC UNION, FIPT x FIPT
- ⑦ 1/4" STAINLESS STEEL WIRE MESH, TYPE 316
- ⑧ CONCRETE BLOCK, TYPICAL OF 4
- ⑨ SCH 80 CLOSE NIPPLE
- ⑩ VALVE BOX EXTENSION (AS NECESSARY)

**NOTES:**

- 1) PLACE AGGREGATE PRIOR TO INSTALLATION OF VALVE BOX.
- 2) A JUMBO RECTANGULAR BOX SHALL BE INSTALLED. BALL VALVES UNDER 2" TO HAVE HANDLE LOCATED VERTICALLY. BALL VALVES LARGER THAN 2" TO HAVE A 2" SQUARE NUT AND DELETE HANDLE.
- 3) CAST IRON AND / OR FLANGED VALVES WILL REQUIRE A POURED-IN-PLACE CONCRETE SUPPORT (NOT SHOWN).

NOT TO SCALE

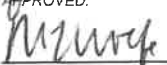
	RECOMMENDED:  DIVISION MANAGER / DATE 9/20/19	<h2 style="margin: 0;">CITY OF MORENO VALLEY</h2> <p style="margin: 0;">PARKS AND COMMUNITY SERVICES DEPARTMENT</p>	STANDARD PLAN <h3 style="margin: 0;">MVLI-551B-0</h3>
	APPROVED:  PUBLIC WORKS DIRECTOR / DATE 10/11/19 CITY ENGINEER	<h3 style="margin: 0;">BALL VALVE / GATE VALVE</h3> <h3 style="margin: 0;">3" OR SMALLER</h3>	SHEET 2 OF 2

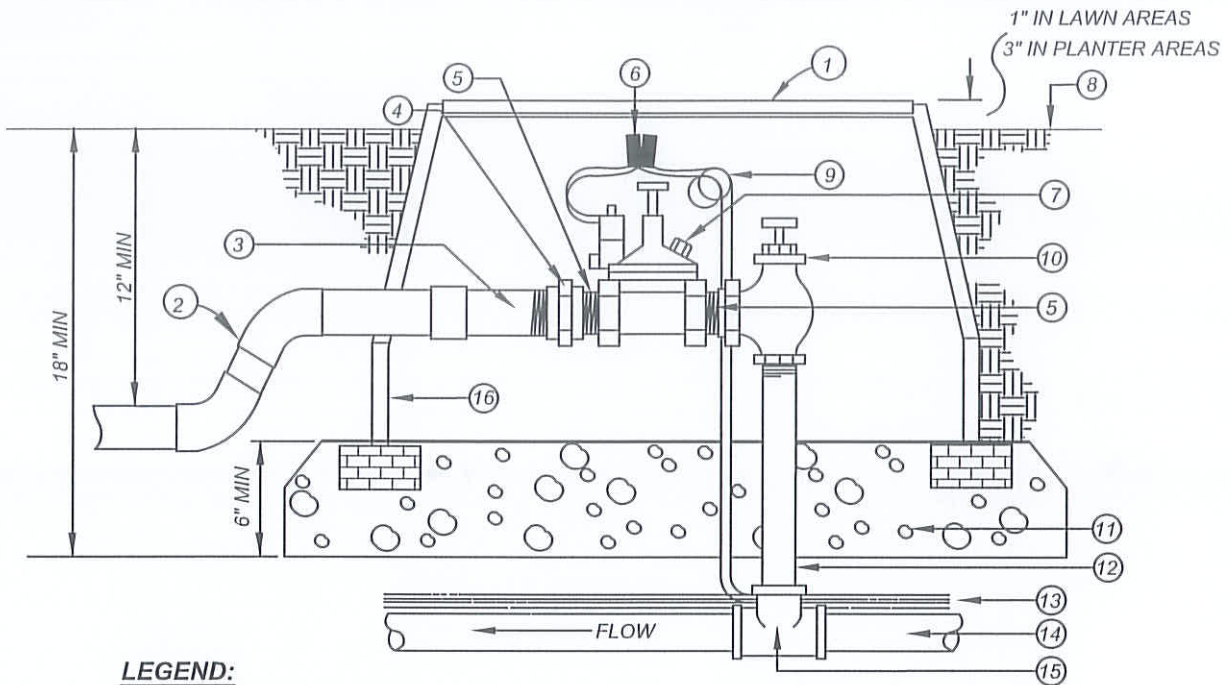

**LEGEND:**

- ① JUMBO RECTANGULAR PLASTIC VALVE BOX WITH LOCKING LID (PER PLAN AS SPECIFIED), SHALL BE "RCV" WITH STATION NUMBERS FOR CONTROL VALVES BRANDED ON LID
- ② PVC LATERAL LINE - ANGLE PIPE TO SPECIFIED DEPTH WITH 45 DEGREE ELLS AS NECESSARY
- ③ SCH 80 PVC TOE NIPPLE ASSEMBLY (REFER TO STANDARD MVLI-544A-0)
- ④ SCH 80 PVC UNION (FIPT x FIPT)
- ⑤ SCH 80 PVC CLOSE NIPPLE
- ⑥ WATER PROOF CONNECTORS, (SEE STANDARD MVLI-545A-0)
- ⑦ ELECTRIC CONTROL VALVE
- ⑧ FINISH GRADE
- ⑨ PIG TAIL EXPANSION LOOP (MIN 24" LONG)
- ⑩ BRASS ANGLE VALVE WITH UNION
- ⑪ WASHED CRUSHED AGGREGATE
- ⑫ SCH 80 PVC NIPPLE
- ⑬ CONTROL & COMMON WIRES (REFER TO STANDARD MVLI-560A-0)
- ⑭ IRRIGATION MAIN-LINE
- ⑮ SCH 80 PVC S x S x S TEE
- ⑯ VALVE BOX EXTENSION (AS NECESSARY)

**NOTES:**

- 1) INSTALL CONTROL VALVES A MINIMUM OF 12" FROM STRUCTURES OR HARDSCAPE.
- 2) INSTALL VALVES IN PLANTER BEDS WHEREVER POSSIBLE NEXT TO SIDEWALKS.
- 3) PLACE VALVE BOX PARALLEL TO STRUCTURES OR HARDSCAPE.
- 4) PLACE AGGREGATE PRIOR TO INSTALLATION OF VALVE BOX.
- 5) ATTACH VALVE IDENTIFICATION TAG WITH APPROPRIATE CONTROLLER DESIGNATION TO CONTROL WIRE.
- 6) ONLY ONE VALVE PER BOX ALLOWED.
- 7) PLACE AGGREGATE PRIOR TO INSTALLATION OF VALVE BOX.

NOT TO SCALE

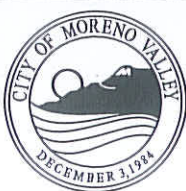

RECOMMENDED:  
 COS 1-16-24  
 DIVISION MANAGER DATE  
 APPROVED:  
 [Signature] 1/29/14  
 PUBLIC WORKS DIRECTOR / DATE  
 CITY ENGINEER

**CITY OF MORENO VALLEY**  
 FINANCIAL & MANAGEMENT SERVICES DEPARTMENT - SPECIAL DISTRICTS DIVISION

**REMOTE CONTROL VALVE  
 WITH UNION**

STANDARD PLAN  
**MVLI-552A-0**  
 SHEET 1 OF 2

**LEGEND:**

- 1 JUMBO/SUPER JUMBO VALVE BOX WITH COVER PER SPECIFICATIONS
- 2 CONNECTORS PER SPECIFICATIONS
- 3 1" ABOVE GRADE TOP IN TURF AREAS  
3" ABOVE GRADE IN SHRUB AREAS
- 4 RAINBIRD EFB-CP-PRS-D RCV (UP TO 2")
- 5 SCH 80 PVC THREADED UNION (2)
- 6 PVC SCH 80 MALE ADAPTER
- 7 LATERAL LINE ANGLE WITH 45 DEGREE ELLS TO SPECIFIED DEPTH
- 8 CONCRETE BRICK SUPPORT AT EACH CORNER
- 9 3/4" GRAVEL SUMP - MINIMUM 6"
- 10 WIRE EXPANSION LOOP (MIN 24" LENGTH)
- 11 FEBCO T585-70-66 BRONZE BALL VALVE
- 12 PVC SCH 80, 90 DEGREE ELL
- 13 SCH 80 SST, MAINLINE SIZE (LEEMCO RESTRAINT TEE ON 4" AND LARGER PIPE)
- 14 CHRISTY TAG WITH VALVE AND STATION NUMBER
- 15 1/4" STAINLESS STEEL WIRE MESH, TYPE 316
- 16 SCH 80 NIPPLE

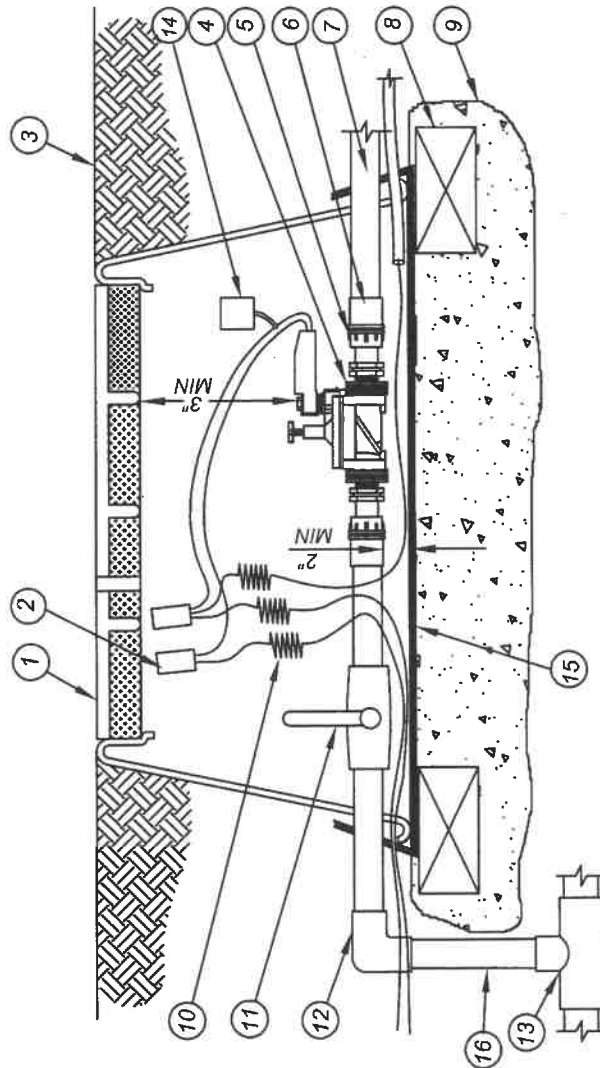

**NOTES:**

- 1.) INSTALL CONTROL VALVES A MINIMUM OF 24" FROM STRUCTURES OR HARDSCAPE.
- 2.) INSTALL VALVES IN PLANT BEDS WHEREVER POSSIBLE NEXT TO SIDEWALKS.
- 3.) PLACE VALVE BOX AT RIGHT ANGLES TO STRUCTURES OR HARDSCAPE.
- 4.) PLACE AGGREGATE PRIOR TO INSTALLATION OF VALVE BOX.
- 5.) ATTACH VALVE IDENTIFICATION TAG WITH APPROPRIATE CONTROLLER AND VALVE NUMBER TO CONTROL WIRE.
- 6.) ONE VALVE PER BOX ALLOWED ONLY.

NOT TO SCALE



RECOMMENDED: *[Signature]* 6/20/19  
 DIVISION MANAGER DATE  
 APPROVED: *[Signature]* 7/30/19  
 PUBLIC WORKS DIRECTOR / DATE  
 CITY ENGINEER

**CITY OF MORENO VALLEY**  
 PARKS AND COMMUNITY SERVICES DEPARTMENT

**REMOTE CONTROL VALVE  
 DETAIL**

STANDARD PLAN  
**MVLI-552B-0**  
 SHEET 2 OF 2



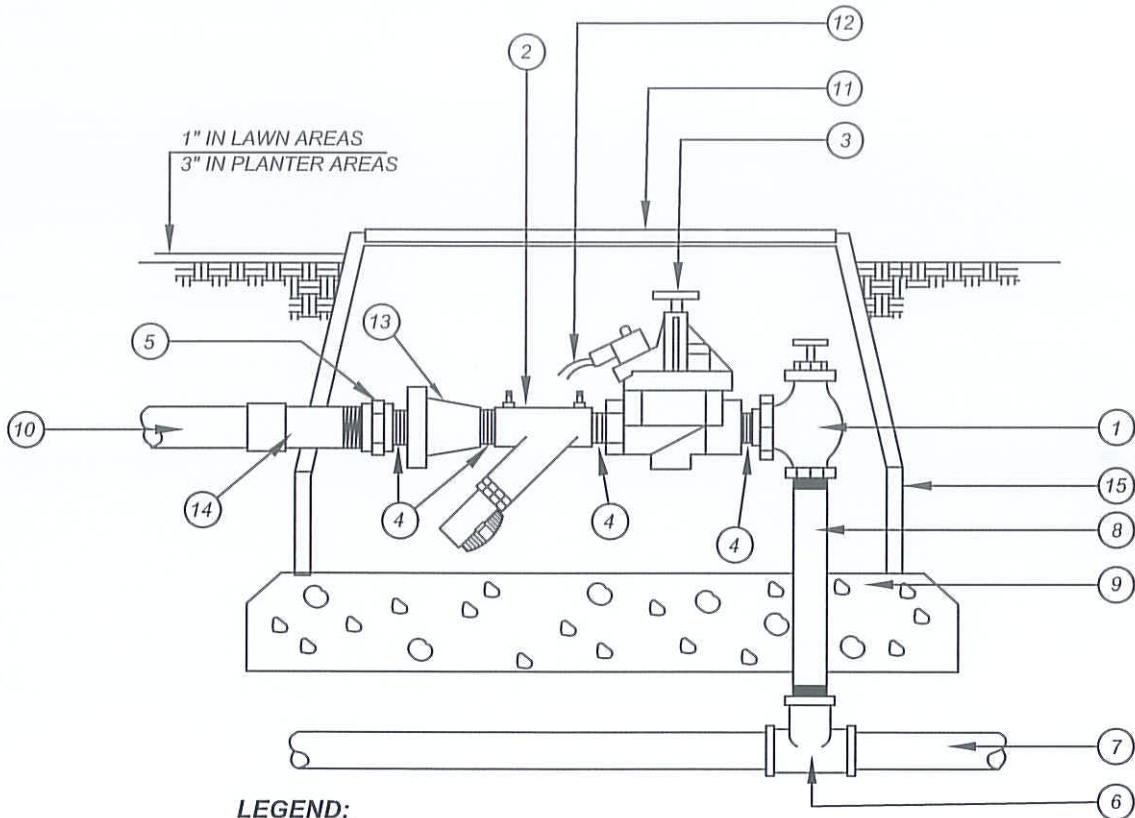

**LEGEND:**

- ① BRASS ANGLE VALVE WITH UNION - SAME SIZE AS RCV
- ② IN-LINE WYE FILTER (PER PLAN AS SPECIFIED)
- ③ REMOTE CONTROL VALVE (PER PLAN AS SPECIFIED)
- ④ SCH 80 PVC CLOSE NIPPLE
- ⑤ SCH 80 UNION (FIPT X FIPT)
- ⑥ SCH 80 PVC S x S x T TEE
- ⑦ IRRIGATION MAIN-LINE
- ⑧ SCH 80 PVC NIPPLE
- ⑨ 6" THICK 3/4" WASHED CRUSHED AGGREGATE
- ⑩ LATERAL LINE (PER PLAN AS SPECIFIED)
- ⑪ JUMBO RECTANGULAR PLASTIC VALVE BOX WITH LOCKING LID (PER PLAN AS SPECIFIED), SHALL BE BRANDED "RCV" WITH STATION NUMBERS FOR CONTROL VALVES
- ⑫ SOLENOID WIRES. PIG-TAIL EACH 24" LONG
- ⑬ PRESSURE REGULATOR (PER PLAN AS SPECIFIED)
- ⑭ SCH 80 TOE NIPPLE ASSEMBLY (REFER TO STANDARD MVLI-544A-0)
- ⑮ VALVE BOX EXTENSION (AS NECESSARY)

**NOTES:**

1) PLACE AGGREGATE PRIOR TO INSTALLING VALVE BOX.

NOT TO SCALE

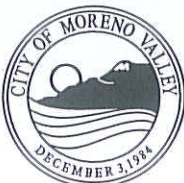

RECOMMENDED:  
*COS* 1-10-14  
 DIVISION MANAGER DATE  
 APPROVED:  
*MM* 1/29/14  
 PUBLIC WORKS DIRECTOR / DATE  
 CITY ENGINEER

**CITY OF MORENO VALLEY**  
 FINANCIAL & MANAGEMENT SERVICES DEPARTMENT - SPECIAL DISTRICTS DIVISION-

**REMOTE CONTROL VALVE  
 FOR DRIP SYSTEMS**

STANDARD PLAN  
**MVLI-553A-0**

SHEET 1 OF 2



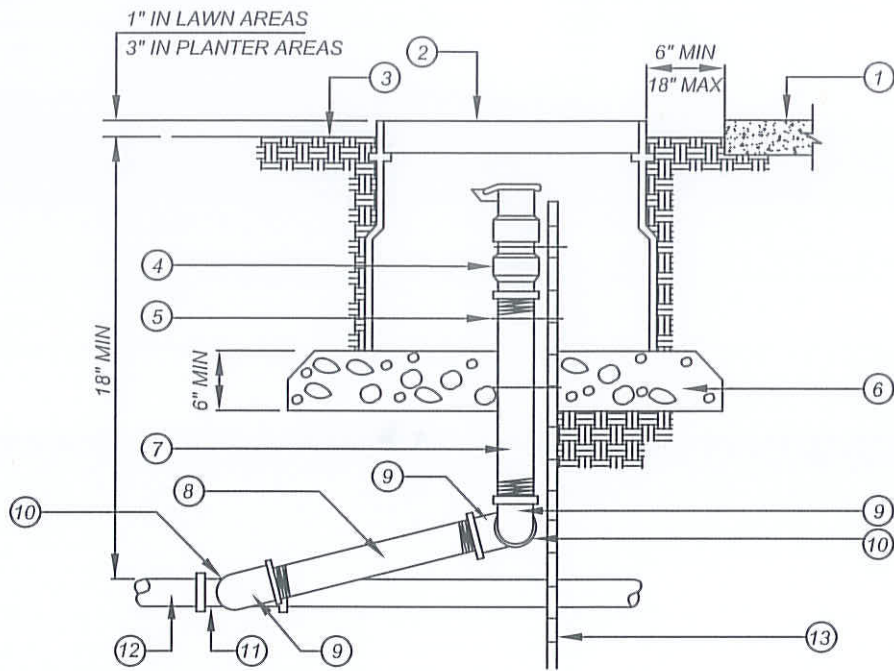

**LEGEND:**

- ① STRUCTURE OR HARDSCAPE
- ② 10" ROUND VALVE BOX WITH "QC" BRANDED ON LID
- ③ FINISH GRADE
- ④ QUICK COUPLING VALVE (PER PLAN AS SPECIFIED)
- ⑤ STAINLESS STEEL SCREW CLAMP MINIMUM (3) PLACES
- ⑥ 3/4" WASHED CRUSHED AGGREGATE BASE
- ⑦ SCH 80 NIPPLE - 10" LONG
- ⑧ SCH 80 NIPPLE - 12" LONG
- ⑨ SCH 80 (FIPT x FIPT) PVC 90 DEGREE ELL
- ⑩ SCH 80 PVC CLOSE NIPPLE
- ⑪ PRESSURE SUPPLY LINE FITTING, (LINE SIZE SCH 80 TEE - S x S x T, OR 90 DEGREE ELL WITH SCH 80 REDUCER BUSHING - SPIG x FIPT)
- ⑫ IRRIGATION MAIN-LINE
- ⑬ No 4 REBAR STAKE (24" LONG)

**NOTES:**

- 1) PLACE AGGREGATE BASE PRIOR TO INSTALLATION OF VALVE BOX.
- 2) INSTALL Q.C.V. & BOX IN PLANTERS WHEN EVER POSSIBLE, NOT IN TURF AREAS.

NOT TO SCALE

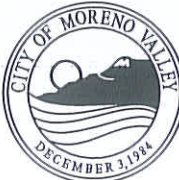
	RECOMMENDED: <div style="font-size: 1.5em; font-family: cursive;">COS</div> DIVISION MANAGER      DATE 1.16.14	<h2 style="margin: 0;">CITY OF MORENO VALLEY</h2> <p style="margin: 0;">FINANCIAL &amp; MANAGEMENT SERVICES DEPARTMENT - SPECIAL DISTRICTS DIVISION</p>	STANDARD PLAN <h3 style="margin: 0;">MVLI-554A-0</h3>
	APPROVED: <div style="font-size: 1.5em; font-family: cursive;">[Signature]</div> PUBLIC WORKS DIRECTOR / DATE 1/29/14 CITY ENGINEER	<h2 style="margin: 0;">QUICK COUPLING VALVE</h2>	SHEET 1 OF 2

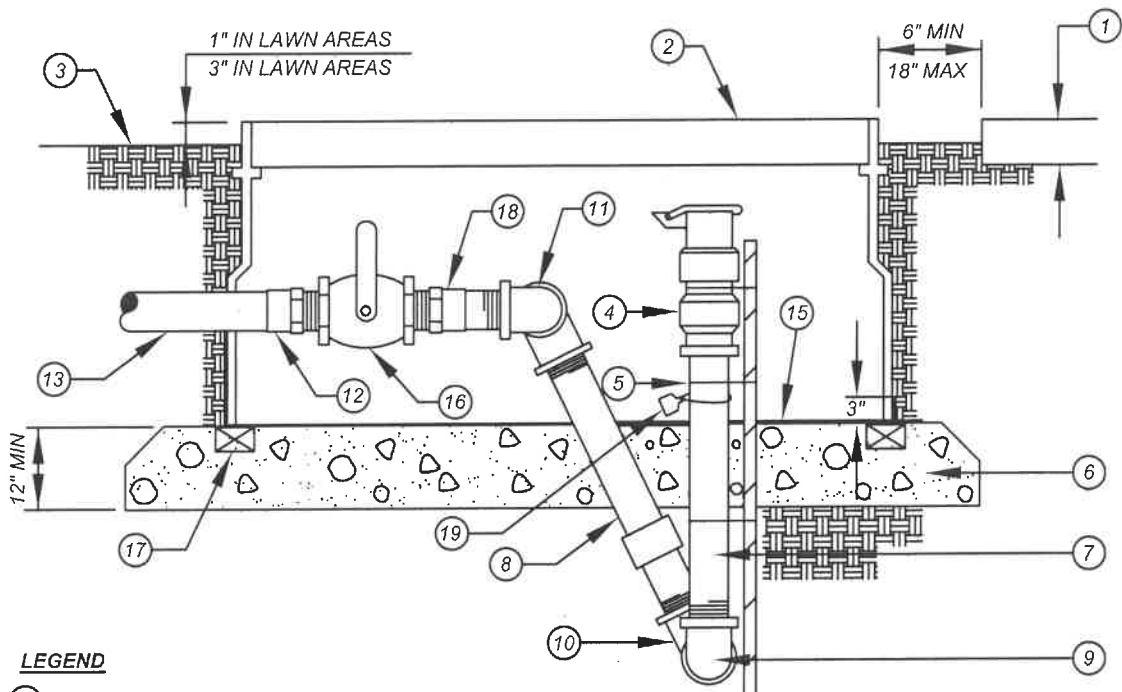

**LEGEND**

- 1 STRUCTURE OR HARDSCAPE
- 2 JUMBO RECTANGULAR PLASTIC VALVE BOX & COVER- COVER SHALL BE HEAT STAMPED WITH LETTERS "QC" HEAT STAMPED INTO COVER BY CONTRACTOR
- 3 FINISH GRADE
- 4 QUICK COUPLING VALVE
- 5 STAINLESS STEEL SCREW, CLAMP MIN (3) PLACES
- 6 3/4" DIA WASHED CRUSHED AGGREGATE
- 7 BRASS NIPPLE
- 8 BRASS NIPPLE - 6" LONG x 1" DIAMETER
- 9 BRASS 90 DEGREE ELL
- 10 BRASS 90 DEGREE STREET ELL
- 11 BRASS 90 DEGREE STREET ELL
- 12 PRESSURE SUPPLY LINE FITTING
- 13 PRESSURE SUPPLY LINE WITH MINIMUM SIZE 1 1/2"
- 14 No 4 BILLET BAR (24" LONG)
- 15 1/4" MESH STAINLESS STEEL SCREEN, TYPE 316
- 16 NIBCO T585-70-66 BALL VALVE - 1 1/2"
- 17 CONCRETE BRICK SUPPORTS (TYP OF 4)
- 18 1" TOE NIPPLE ASSEMBLY AND REDUCER BUSHING
- 19 CHRISTY TAG LABELLED "DO NOT DRINK" WITH SYMBOL

**NOTES:**

1. PLACE STABILIZER PRIOR TO INSTALLATION OF VALVE BOX

NOT TO SCALE



RECOMMENDED:

DIVISION MANAGER

DATE

APPROVED:

PUBLIC WORKS DIRECTOR/

DATE

CITY ENGINEER

**CITY OF MORENO VALLEY**

PARKS AND COMMUNITY SERVICES DEPARTMENT

**QUICK COUPLER BALL VALVE**

STANDARD PLAN

**MVLI-554B-0**

SHEET 2 OF 2



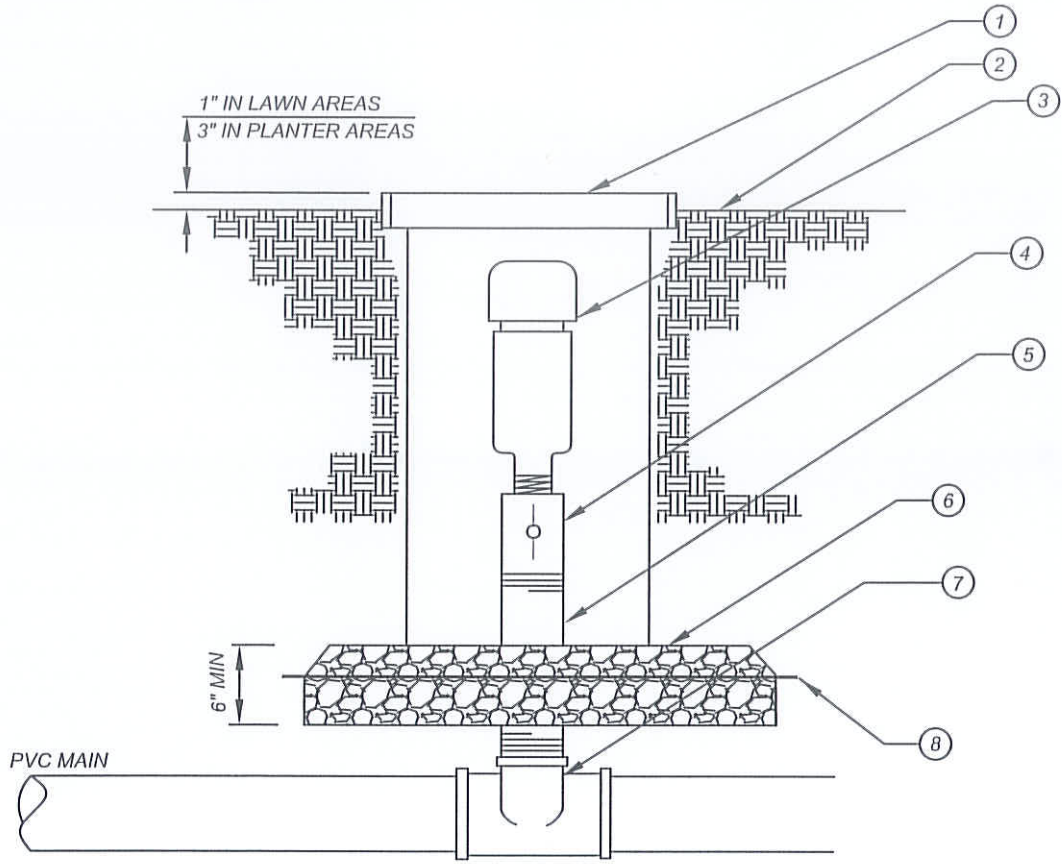

**LEGEND:**

- ① 10" ROUND VALVE BOX WITH LOCKING LID, "ARV" TO BE BRANDED ON LID. USE VALVE BOX EXTENSIONS AS NECESSARY TO REACH FINISH GRADE
- ② FINISH GRADE
- ③ 1" AIR/VACUUM RELIEF VALVE
- ④ 1" SCH 80 PVC BALL VALVE (FIPT X FIPT)
- ⑤ 1" SCH 80 PVC NIPPLE
- ⑥ 3/4" WASHED CRUSHED AGGREGATE BASE
- ⑦ SCH 80 PVC TEE (S x S x T) OR 90° ELL (S x T)
- ⑧ 1/4" GALVANIZED MESH WIRE

**NOTES:**

- 1) PLACE AGGREGATE PRIOR TO INSTALLATION OF BOX.

NOT TO SCALE

	RECOMMENDED: <div style="font-size: 1.5em; font-family: cursive;">COS</div> DIVISION MANAGER      DATE 1-16-14	<h2 style="margin: 0;">CITY OF MORENO VALLEY</h2> <p style="margin: 0;">FINANCIAL &amp; MANAGEMENT SERVICES DEPARTMENT - SPECIAL DISTRICTS DIVISION</p>		
	APPROVED: <div style="font-size: 1.5em; font-family: cursive;">[Signature]</div> PUBLIC WORKS DIRECTOR / DATE 1/29/14	<h3 style="margin: 0;">AIR VACUUM RELIEF VALVE</h3>		STANDARD PLAN <h3 style="margin: 0;">MVLI-555A-0</h3>
	CITY ENGINEER	SHEET 1 OF 2		

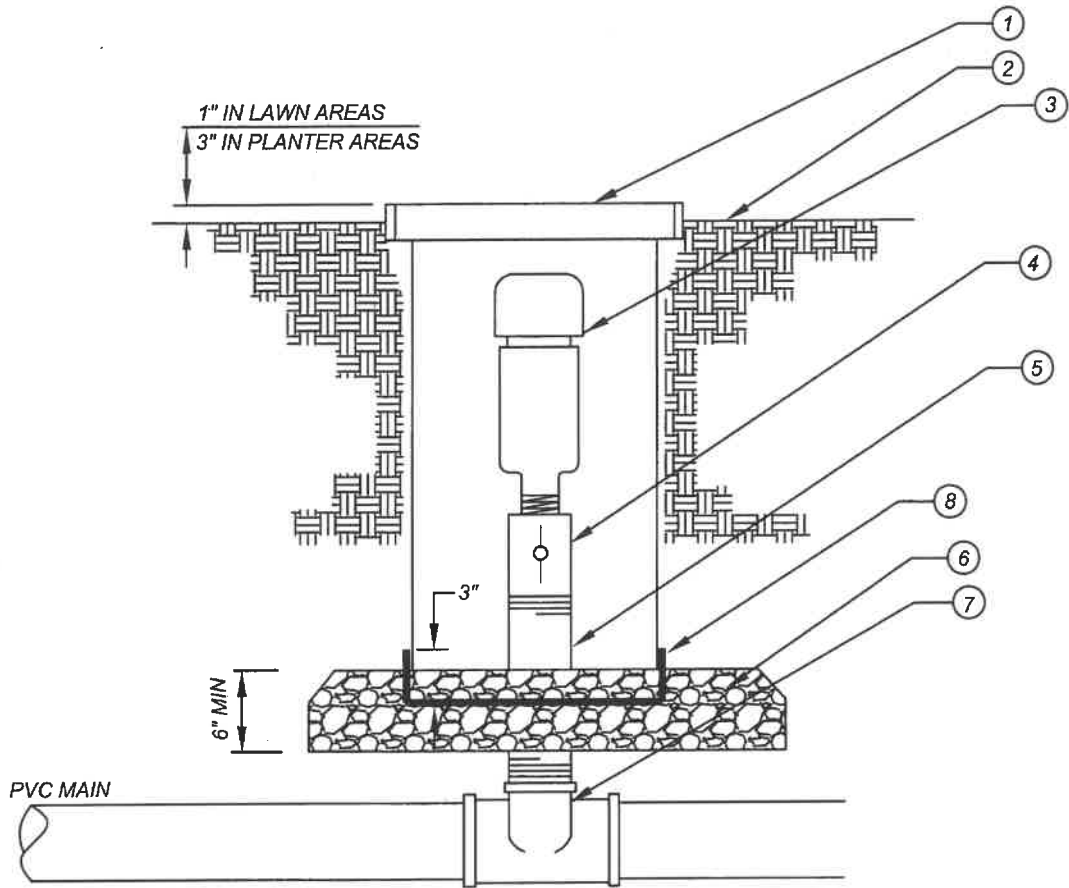

**LEGEND:**

- ① 10" ROUND VALVE BOX WITH LOCKING LID, "ARV" TO BE BRANDED ON LID. USE VALVE BOX EXTENSIONS AS NECESSARY TO REACH FINISH GRADE
- ② FINISH GRADE
- ③ 1" AIR/VACUUM RELIEF VALVE
- ④ 1" SCH 80 PVC BALL VALVE (FIPT X FIPT)
- ⑤ 1" SCH 80 PVC NIPPLE
- ⑥ 3/4" WASHED CRUSHED AGGREGATE BASE
- ⑦ SCH 80 PVC TEE (S x S x T) OR 90° ELL (S x T)
- ⑧ 1/4" STAINLESS STEEL WIRE MESH WIRE, TYPE 316

**NOTES:**

- 1) PLACE AGGREGATE PRIOR TO INSTALLATION OF BOX.

NOT TO SCALE

	RECOMMENDED:  DIVISION MANAGER      DATE	<h2 style="margin: 0;">CITY OF MORENO VALLEY</h2> <p style="margin: 0;">PARKS AND COMMUNITY SERVICES DEPARTMENT</p>	STANDARD PLAN
	APPROVED:  PUBLIC WORKS DIRECTOR / DATE CITY ENGINEER	<h3 style="margin: 0;">AIR VACUUM RELIEF VALVE</h3>	<b>MVLI-555B-0</b>

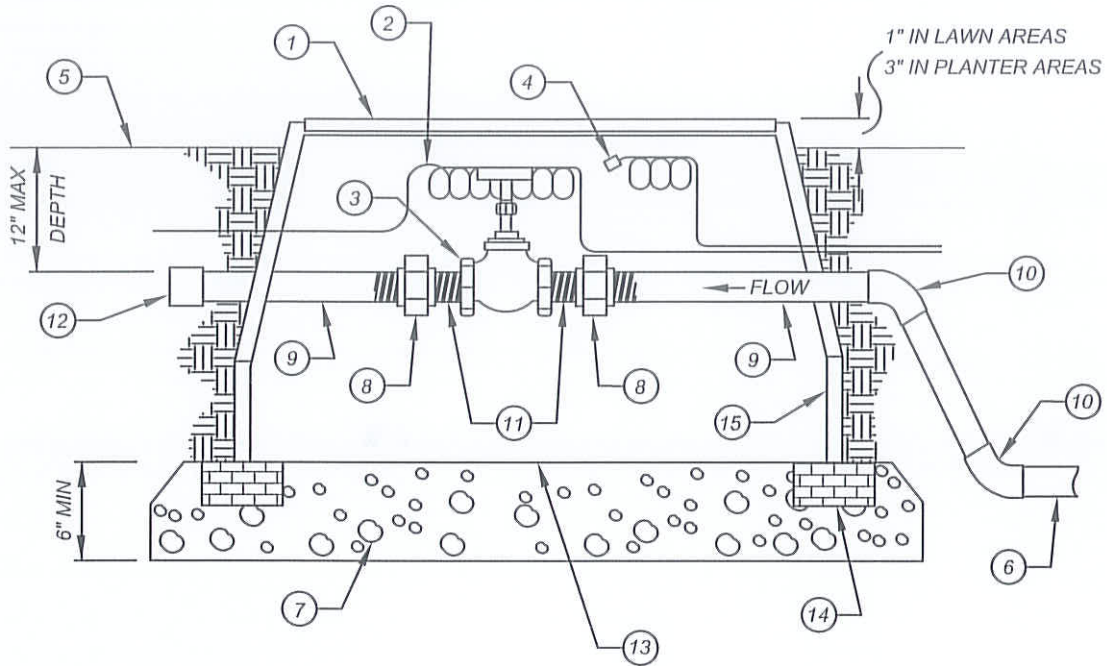

**LEGEND:**

- |  |  |
|--|--|
| ① JUMBO RECTANGULAR PLASTIC VALVE BOX WITH LOCKING LID (PER PLAN AS SPECIFIED) BRANDED WITH "GV" OR "BV" | ⑦ 3/4" WASHED CRUSHED AGGREGATE BASE                         |
| ② PIG-TAIL COMMON WIRE (CONTINUOUS LOOP)   | ⑧ SCH 80 UNION (FIPT x FIPT)                                 |
| ③ BALL VALVE OR GATE VALVE (PER PLAN AS SPECIFIED)   | ⑨ SCH 80 TOE NIPPLE ASSEMBLY (REFER TO STANDARD MVLI-544A-0) |
| ④ PIG-TAIL PILOT WIRE AND WATERPROOF END (REFER TO STANDARD MVLI-545A-0)                                 | ⑩ SCH 80 45° ELBOWS  |
| ⑤ FINISH GRADE   | ⑪ SCH 80 PVC CLOSE NIPPLES                                   |
| ⑥ IRRIGATION MAIN-LINE   | ⑫ SCH 80 PVC CAP   |
|  | ⑬ 1/4" GALVANIZED WIRE MESH                                  |
|  | ⑭ CONCRETE BRICK, TYPICAL OF 4                               |
|  | ⑮ VALVE BOX EXTENSION (AS NECESSARY)                         |

**NOTES:**

- 1) PLACE AGGREGATE AND MESH PRIOR TO INSTALLING BOX.

NOT TO SCALE

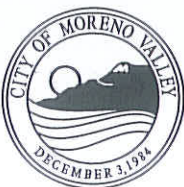

RECOMMENDED:  
 COS 1-16-14  
 DIVISION MANAGER DATE  
 APPROVED:  
 [Signature] 1/29/14  
 PUBLIC WORKS DIRECTOR / DATE  
 CITY ENGINEER

**CITY OF MORENO VALLEY**  
 FINANCIAL & MANAGEMENT SERVICES DEPARTMENT - SPECIAL DISTRICTS DIVISION

**IRRIGATION STUB-OUT BOX**

STANDARD PLAN  
**MVLI-556A-0**

SHEET 1 OF 2

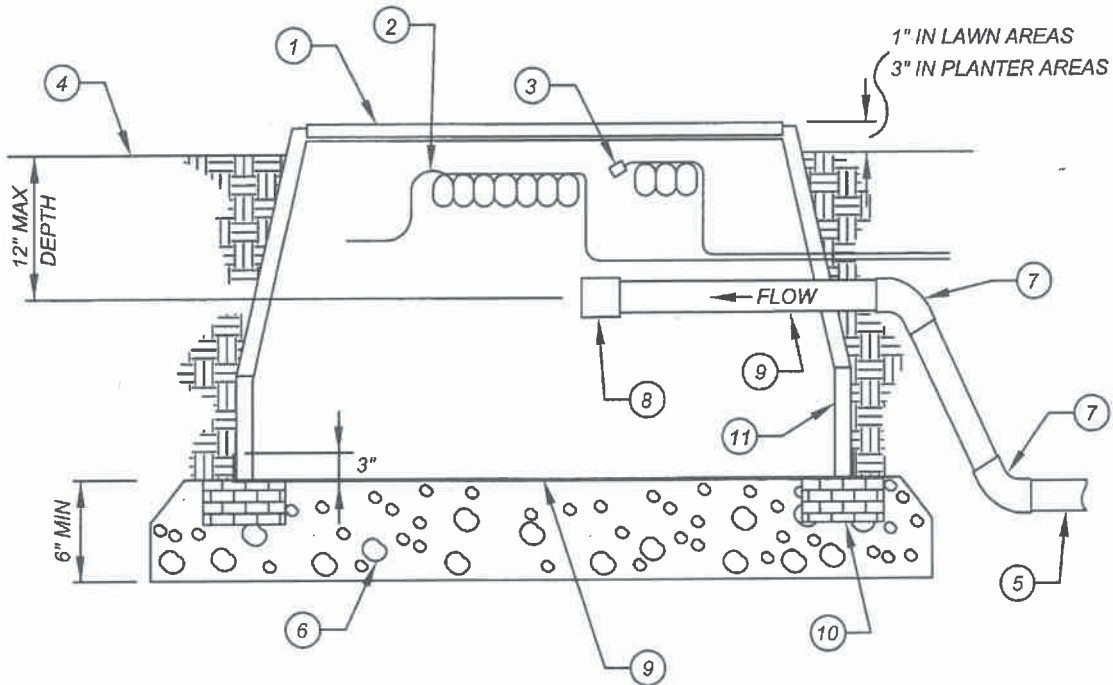

**LEGEND:**

- |  |  |
|--|--|
| ① JUMBO RECTANGULAR PLASTIC VALVE BOX WITH LOCKING LID (PER PLAN AS SPECIFIED) BRANDED WITH "GV" OR "BV" | ⑥ 3/4" WASHED CRUSHED AGGREGATE BASE       |
| ② PIG-TAIL COMMON WIRE (CONTINUOUS LOOP)   | ⑦ SCH 80 45° ELBOWS                        |
| ③ PIG-TAIL PILOT WIRE AND WATERPROOF END   | ⑧ SCH 80 PVC CAP                           |
| ④ FINISH GRADE   | ⑨ 1/4" STAINLESS STEEL WIRE MESH, TYPE 316 |
| ⑤ IRRIGATION MAIN-LINE   | ⑩ CONCRETE BRICK, TYPICAL OF 4             |
|  | ⑪ VALVE BOX EXTENSION (AS NECESSARY)       |

**NOTES:**

1) PLACE AGGREGATE AND MESH PRIOR TO INSTALLING BOX.

NOT TO SCALE



RECOMMENDED:

DIVISION MANAGER

DATE

APPROVED:

Mt. Wolfe

7/30/19

PUBLIC WORKS DIRECTOR /  
CITY ENGINEER

DATE

**CITY OF MORENO VALLEY**

PARKS AND COMMUNITY SERVICES DEPARTMENT

**IRRIGATION STUB-OUT BOX**

STANDARD PLAN

**MVLI-556B-0**

SHEET 2 OF 2



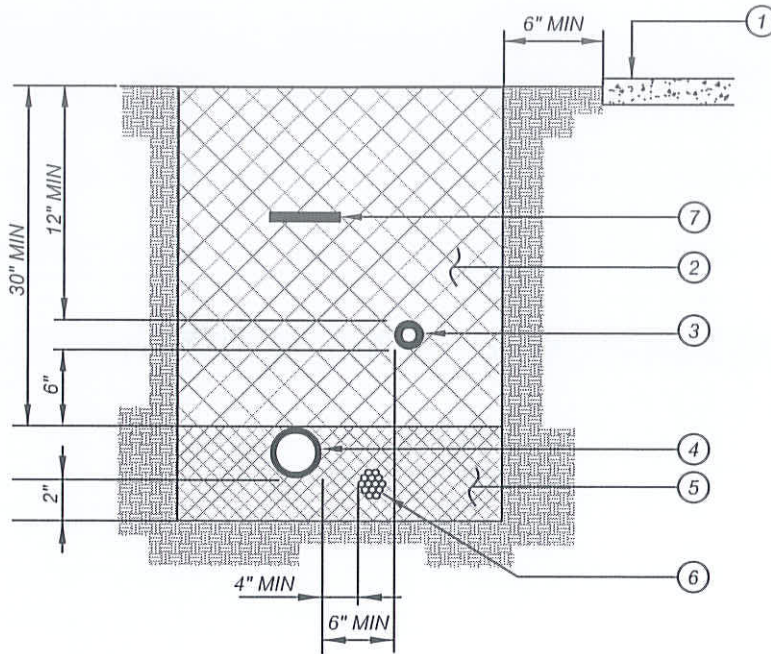



**LEGEND:**

- ① ADJACENT WALK OR FINISHED SURFACE
- ② CLEAN BACKFILL - SEE SPECIFICATIONS FOR MATERIAL, 90% COMPACTION REQUIRED
- ③ NON-PRESSURE LATERAL LINE
- ④ IRRIGATION MAIN-LINE
- ⑤ PROVIDE WASHED SAND BACKFILL
- ⑥ CONTROL WIRES - BUNDLE AND TAPE AT 15' OC AND INSTALL BELOW AND OFFSET FROM IRRIGATION MAIN-LINE
- ⑦ WATER WARNING TAPE PER CITY LANDSCAPE GUIDELINES

**NOTES:**

- 1.) PIGTAIL AND/OR LOOP CONTROL WIRE AT ALL 90 DEGREE CHANGES IN DIRECTION
- 2.) SPLICING OF WIRE RUN PER CITY LANDSCAPE SPECIFICATIONS ONLY
- 3.) 30" MINIMUM COVER FOR RECLAIMED WATER MAINLINE

NOT TO SCALE

	RECOMMENDED:  1-16-14 DIVISION MANAGER      DATE	<h2 style="margin: 0;">CITY OF MORENO VALLEY</h2> <p style="margin: 0;">FINANCIAL &amp; MANAGEMENT SERVICES DEPARTMENT - SPECIAL DISTRICTS DIVISION</p>	STANDARD PLAN <h3 style="margin: 0;">MVLI-560A-0</h3>
	APPROVED:  1/29/14 PUBLIC WORKS DIRECTOR / DATE CITY ENGINEER	<h2 style="margin: 0;">LANDSCAPE TRENCH DETAIL</h2>	

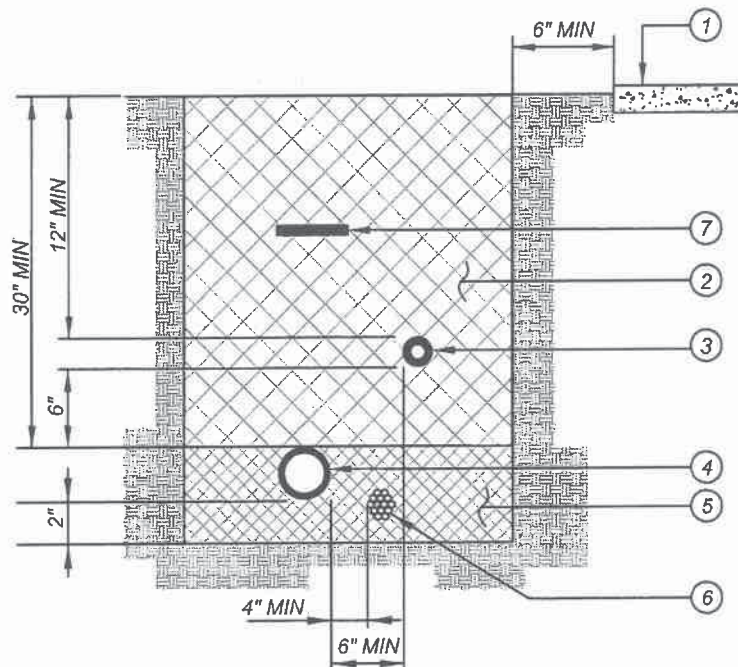

**LEGEND:**

- ① ADJACENT WALK OR FINISHED SURFACE
- ② CLEAN BACKFILL - SEE SPECIFICATIONS FOR MATERIAL, 90% COMPACTION REQUIRED
- ③ NON-PRESSURE LATERAL LINE
- ④ IRRIGATION MAIN LINE OR POTABLE WATER LINE
- ⑤ PROVIDE WASHED SAND BACKFILL
- ⑥ CONTROL WIRES - BUNDLE AND TAPE AT 8' OC AND INSTALL BELOW AND OFFSET FROM IRRIGATION MAIN LINE
- ⑦ DETECTABLE WARNING TAPE

**NOTES:**

- 1.) PIGTAIL AND/OR LOOP CONTROL WIRE AT ALL 90 DEGREE CHANGES IN DIRECTION
- 2.) SPLICING OF WIRE RUN PER CITY LANDSCAPE SPECIFICATIONS ONLY
- 3.) 30" MINIMUM COVER FOR RECLAIMED WATER MAINLINE

NOT TO SCALE

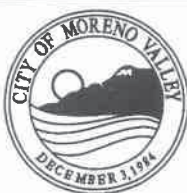

RECOMMENDED: *[Signature]* *6/30/19*  
 DIVISION MANAGER DATE  
 APPROVED: *[Signature]* *7/30/19*  
 PUBLIC WORKS DIRECTOR / DATE  
 CITY ENGINEER

**CITY OF MORENO VALLEY**

PARKS AND COMMUNITY SERVICES DEPARTMENT

**TRENCH DETAIL**

STANDARD PLAN  
**MVLI-560B-0**

SHEET 2 OF 2

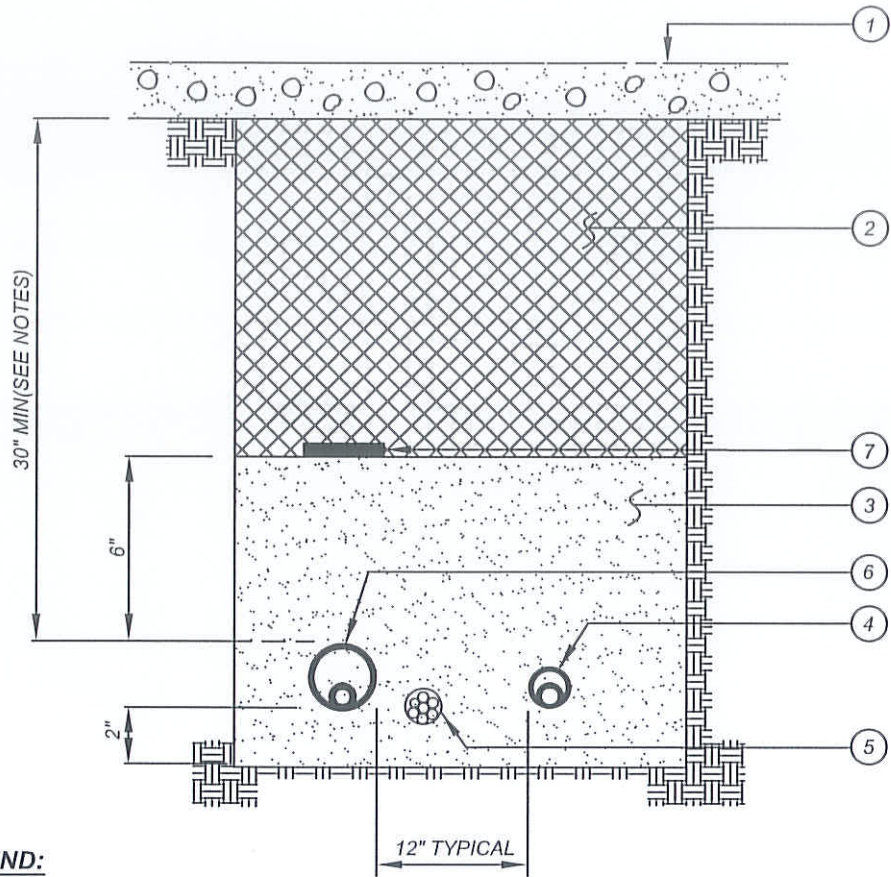



**LEGEND:**

- ① HARDSCAPING
- ② CLEAN BACKFILL - SEE SPECS. FOR MATERIAL, 90% COMPACTION REQUIRED
- ③ WASHED SAND
- ④ NON-PRESSURE LATERAL LINE SLEEVE SIZE TWICE DIAMETER OF NON-PRESSURE LATERAL LINE
- ⑤ CONTROL WIRE SLEEVE - SIZE PER PLAN, INSTALL ADJACENT TO IRRIGATION MAIN-LINE
- ⑥ IRRIGATION MAIN-LINE SLEEVE - SIZE TWICE DIAMETER OF IRRIGATION MAIN-LINE
- ⑦ WATER TAPE, 6" ABOVE WATER PIPE AND PER EMWD REQUIREMENTS

**NOTES:**

- 1) ALL SLEEVES TO BE SCH 40 PVC.
- 2) EXTEND ALL SLEEVES 12" BEYOND EDGE OF HARDSCAPE AT BOTH ENDS.
- 3) RECLAIMED WATER SLEEVING TO BE 30" DEPTH MINIMUM.

NOT TO SCALE

	RECOMMENDED:  DIVISION MANAGER      DATE	<h2 style="margin: 0;">CITY OF MORENO VALLEY</h2> <p style="margin: 0;">FINANCIAL &amp; MANAGEMENT SERVICES DEPARTMENT - SPECIAL DISTRICTS DIVISION</p>
	APPROVED:  PUBLIC WORKS DIRECTOR / DATE CITY ENGINEER	<h3 style="margin: 0;">SLEEVING DETAIL</h3>



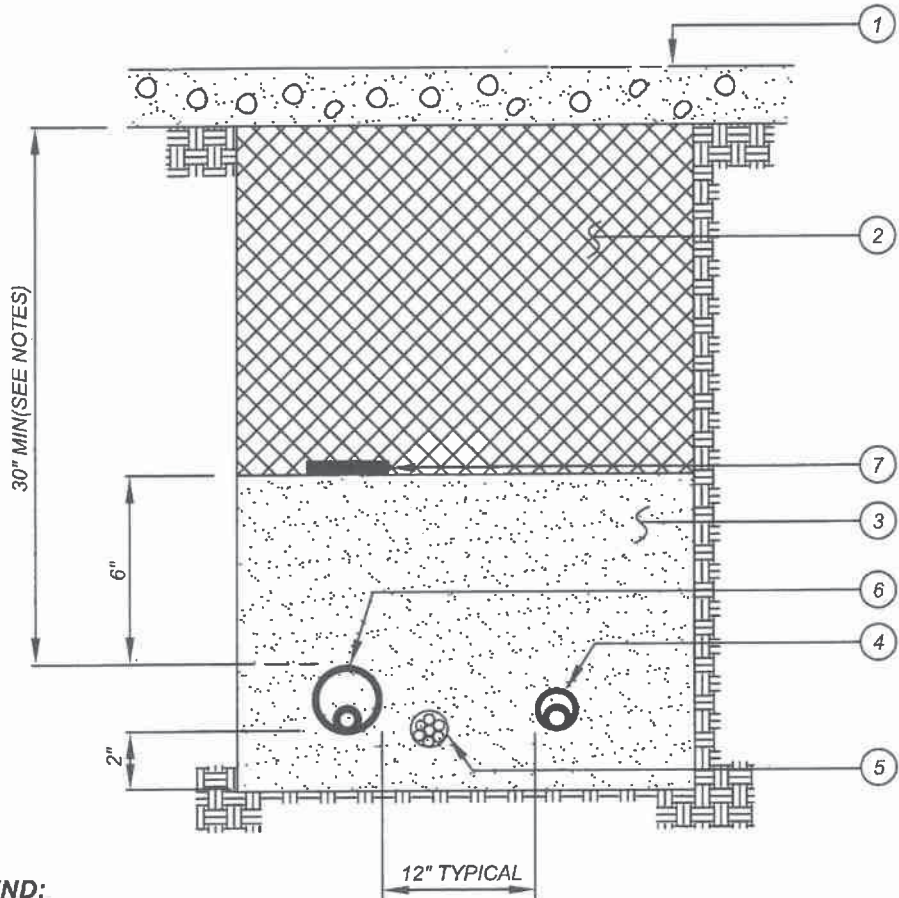



**LEGEND:**

- ① HARDSCAPING
- ② CLEAN BACKFILL - SEE SPECS. FOR MATERIAL, 90% COMPACTION REQUIRED
- ③ WASHED SAND
- ④ NON-PRESSURE LATERAL LINE SLEEVE SIZE TWICE DIAMETER OF NON-PRESSURE LATERAL LINE
- ⑤ CONTROL WIRE SLEEVE - SIZE PER PLAN, INSTALL ADJACENT TO IRRIGATION MAIN-LINE
- ⑥ IRRIGATION MAIN-LINE SLEEVE - SIZE TWICE DIAMETER OF IRRIGATION MAIN-LINE
- ⑦ DETECTABLE WATER TAPE, 6" ABOVE WATER PIPE AND PER EMWD REQUIREMENTS

**NOTES:**

- 1) ALL SLEEVES TO BE SCH 80 PVC.
- 2) EXTEND ALL SLEEVES 12" MINIMUM BEYOND EDGE OF HARDSCAPE AT BOTH ENDS PER LOCAL JURISDICTION.
- 3) RECLAIMED WATER SLEEVING TO BE 30" DEPTH MINIMUM.

NOT TO SCALE

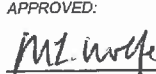
	RECOMMENDED:  DIVISION MANAGER      DATE 6/20/19	<h2 style="margin: 0;">CITY OF MORENO VALLEY</h2> <p style="margin: 0;">PARKS AND COMMUNITY SERVICES DEPARTMENT</p>	STANDARD PLAN <b>MVLI-561B-0</b>
	APPROVED:  PUBLIC WORKS DIRECTOR / DATE 7/30/19 CITY ENGINEER	<h3 style="margin: 0;">SLEEVING DETAIL</h3>	SHEET 2 OF 2



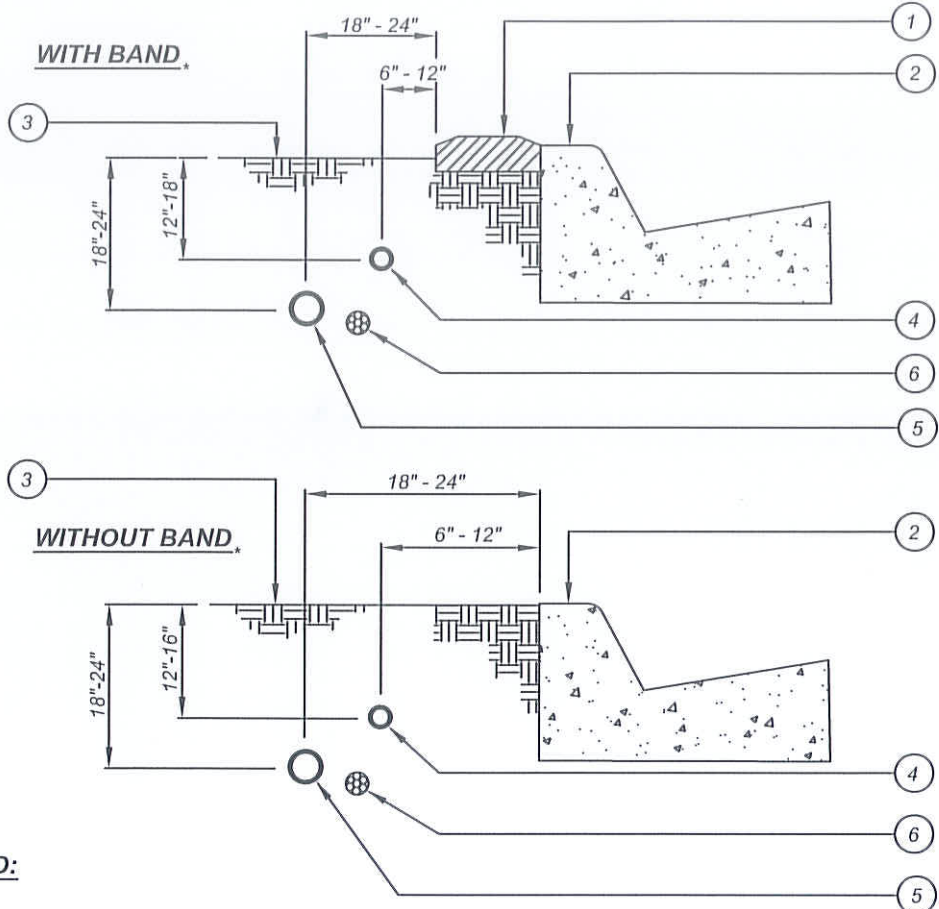

**LEGEND:**

- ① STAMPED CONCRETE, PAVER, ETC.
- ② CONC CURB
- ③ FINISH GRADE
- ④ LATERAL LINE LOCATION
- ⑤ MAIN LINE LOCATION
- ⑥ WIRE BUNDLE

**NOTE:**

- 1.) PIPES PLACED IN A COMMON TRENCH SHALL HAVE A VERTICAL & HORIZONTAL OFFSET OF 4" MINIMUM.
- \* FOR MEDIANS LESS THEN 18' WIDE, HORIZONTAL OFFSET FROM CURB/HARDSCAPE SHALL BE AS DETERMINED BY CITY ENGINEER.

NOT TO SCALE

	RECOMMENDED:  1-16-14 DIVISION MANAGER      DATE	<b>CITY OF MORENO VALLEY</b> FINANCIAL & MANAGEMENT SERVICES DEPARTMENT - SPECIAL DISTRICTS DIVISION	STANDARD PLAN
	APPROVED:  1/29/14 PUBLIC WORKS DIRECTOR / DATE CITY ENGINEER	<b>MEDIAN AND PARKWAY IRRIGATION LINE INSTALLATION</b>	<b>MVLI-562-0</b>
			SHEET 1 OF 1

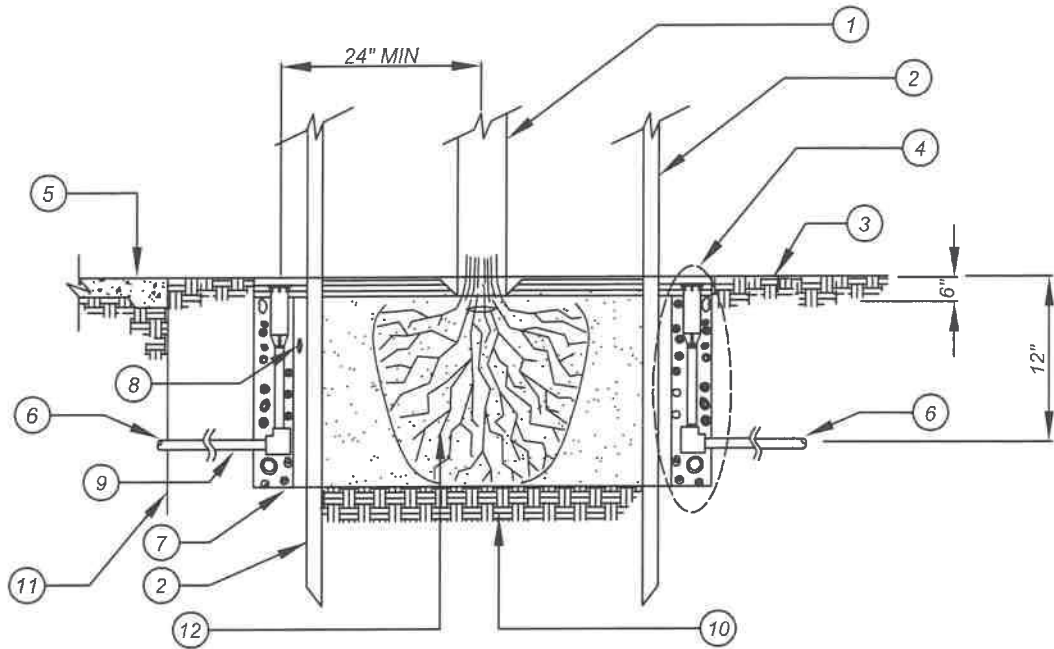



**LEGEND:**

- ① TREE TRUNK
- ② 2" LODGE POLE STAKES (PER CITY STANDARDS)
- ③ FINISH GRADE: TO BE DETERMINED AND APPROVED BY SPECIAL DISTRICTS IN THE FIELD
- ④ ROOT WATERING SYSTEM (RWS) (PER PLAN AS SPECIFIED), CONNECT TO LATERAL LINE PER MANUFACTURER'S RECOMMENDATIONS, AND AS APPROVED BY SPECIAL DISTRICTS. FILL WITH 1/2" AGGREGATE TO SPECIFIED LEVEL
- ⑤ CONCRETE SIDEWALK
- ⑥ NON-PRESSURE LATERAL LINE
- ⑦ PLANTING PIT: 2 TIMES WIDTH OF ROOTBALL AND SAME DEPTH AS ROOTBALL
- ⑧ PLANT TABLETS PER MANUFACTURER'S RECOMMENDATIONS (DISTRIBUTED AROUND ROOTBALL)
- ⑨ CONNECT TO LATERAL LINE PER MANUFACTURER'S RECOMMENDATIONS, AND AS APPROVED BY SPECIAL DISTRICTS
- ⑩ UNDISTURBED NATIVE SOIL
- ⑪ INSTALL VERTICAL ROOT BARRIER PER MFG. INSTRUCTIONS (WHERE SPECIFIED)
- ⑫ ROOTBALL

**NOTES:**

- 1) SUPPLEMENTAL TREE IRRIGATION: 1 RWS FOR 5 GALLON TREES. 2 RWS FOR 15 GALLON TREES AND LARGER.

NOT TO SCALE

	RECOMMENDED:  7/22/19 DIVISION MANAGER      DATE	<h2 style="margin: 0;">CITY OF MORENO VALLEY</h2> <p style="margin: 0;">PUBLIC WORKS DEPARTMENT - SPECIAL DISTRICTS DIVISION</p>	STANDARD PLAN <b>MVLI-563A-0</b>
	APPROVED:  7/30/19 PUBLIC WORKS DIRECTOR / DATE CITY ENGINEER	<h3 style="margin: 0;">DEEP WELL TREE IRRIGATION</h3>	

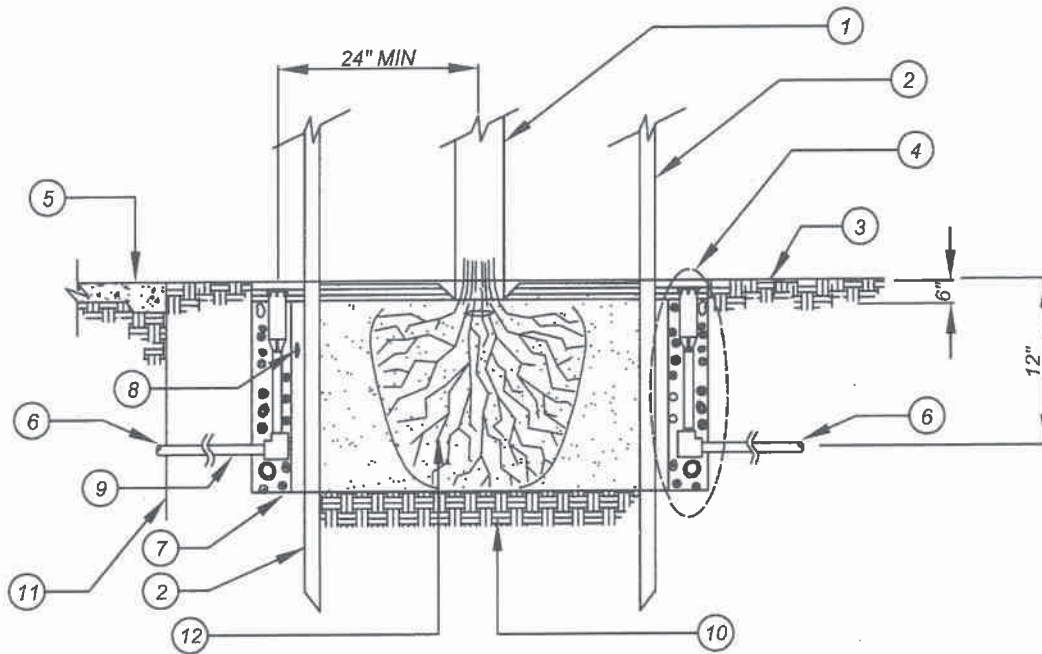



**LEGEND:**

- ① TREE TRUNK
- ② 2" LODGE POLE STAKES (PER CITY STANDARDS)
- ③ FINISH GRADE: TO BE DETERMINED AND APPROVED BY PARKS AND COMMUNITY SERVICES IN THE FIELD
- ④ ROOT WATERING SYSTEM (RWS) WITH MFG. DRAIN SOCK (PER PLAN AS SPECIFIED), CONNECT TO LATERAL LINE PER MANUFACTURER'S RECOMMENDATIONS, AND AS APPROVED BY PARKS AND COMMUNITY SERVICES. FILL WITH 3/4" AGGREGATE TO SPECIFIED LEVEL
- ⑤ CONCRETE SIDEWALK
- ⑥ NON-PRESSURE LATERAL LINE
- ⑦ PLANTING PIT: 2 TIMES WIDTH OF ROOTBALL AND SAME DEPTH AS ROOTBALL
- ⑧ PLANT TABLETS PER MANUFACTURER'S RECOMMENDATIONS (DISTRIBUTED AROUND ROOTBALL)
- ⑨ CONNECT TO LATERAL LINE PER MANUFACTURER'S RECOMMENDATIONS, AND AS APPROVED BY PARKS AND COMMUNITY SERVICES
- ⑩ UNDISTURBED NATIVE SOIL
- ⑪ INSTALL VERTICAL ROOT BARRIER PER MFG. INSTRUCTIONS (WHERE SPECIFIED)
- ⑫ ROOTBALL

**NOTES:**

- 1) SUPPLEMENTAL TREE IRRIGATION: 3 RWS FOR 15 GALLON TREES AND LARGER.

NOT TO SCALE

	RECOMMENDED:  DIVISION MANAGER      DATE	<b>CITY OF MORENO VALLEY</b> PARKS AND COMMUNITY SERVICES DEPARTMENT	STANDARD PLAN
	APPROVED:  PUBLIC WORKS DIRECTOR / DATE CITY ENGINEER		<b>DEEP WELL TREE IRRIGATION</b> <b>MVLI-563B-0</b>
			SHEET 2 OF 2

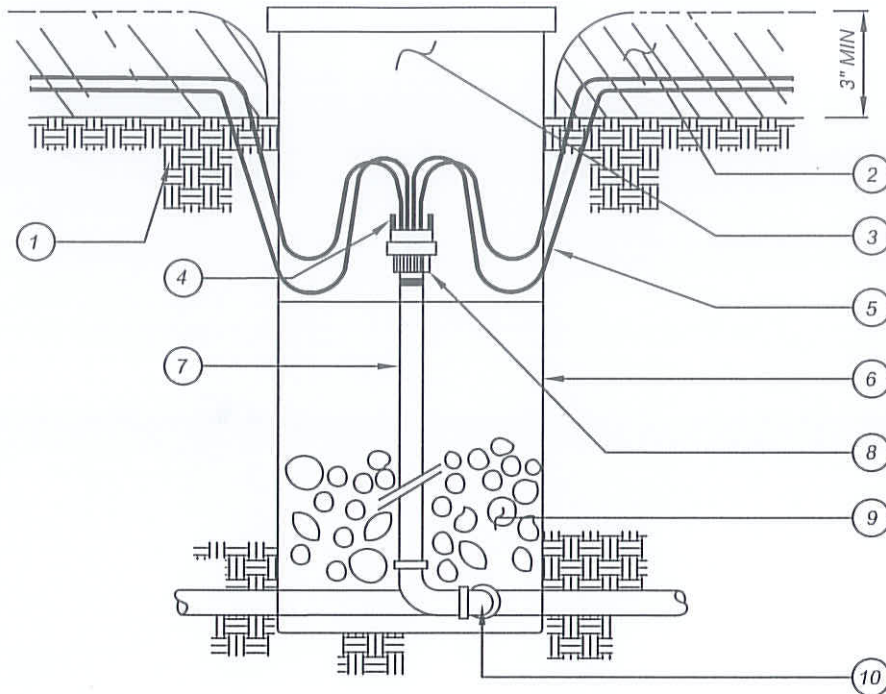



**LEGEND:**

- ① FINISH GRADE
- ② MEDIUM GRIND SHREDDED MULCH COVER OVER DIST. TUBES -IN PLANTER BEDS
- ③ VALVE BOX 3" ABOVE FINISH GRADE
- ④ EMITTER OUTLET - CAP/PLUG UNUSED OUTLETS IF NECESSARY
- ⑤ DISTRIBUTION TUBES WITH OUTLET CHECK VALVE CAPS. (MIN 2 PER SHRUB) INSTALL WITH PLASTIC TUBE STAKES.
- ⑥ 10" PLASTIC VALVE BOX BRANDED "EMT" ON LID
- ⑦ 1/2" DIA SCH 80 PVC NIPPLE LENGTH AS REQUIRED
- ⑧ MULTI-OUTLET EMITTER WITH THREADED RISER ADAPTER, (1 PER 2 OR 3 SHRUBS).  
1 EMITTER FOR 5 GALLON TREES AND 2 EMITTERS PER 15 GALLON AND LARGER TREES.
- ⑨ 3/8" WASHED AGGREGATE. LEAVE SPACE BETWEEN EMITTER AND TOP OF AGGREGATE.
- ⑩ MARLEX DOUBLE STREET ELLS BETWEEN LATERAL LINE AND RISER.

**NOTES:**

- 1) INSTALL TWO MULTI EMITTERS 18" FROM TRUNK OF EVERY TREE (DO NOT USE DISTRIBUTION TUBING).
- 2) INSTALL ONE MULTI EMITTER PER SIX GROUND COVER PLANTS (ONE DISTRIBUTION TUBE PER PLANT).

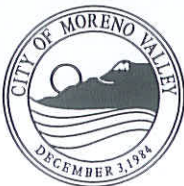
NOT TO SCALE

	RECOMMENDED:  1.16.14 DIVISION MANAGER      DATE	<b>CITY OF MORENO VALLEY</b> FINANCIAL & MANAGEMENT SERVICES DEPARTMENT - SPECIAL DISTRICTS DIVISION	STANDARD PLAN <b>MVLI-564-0</b>
	APPROVED:  1/29/14 PUBLIC WORKS DIRECTOR / DATE CITY ENGINEER	<b>DRIP EMITTER INSTALLATION</b>	



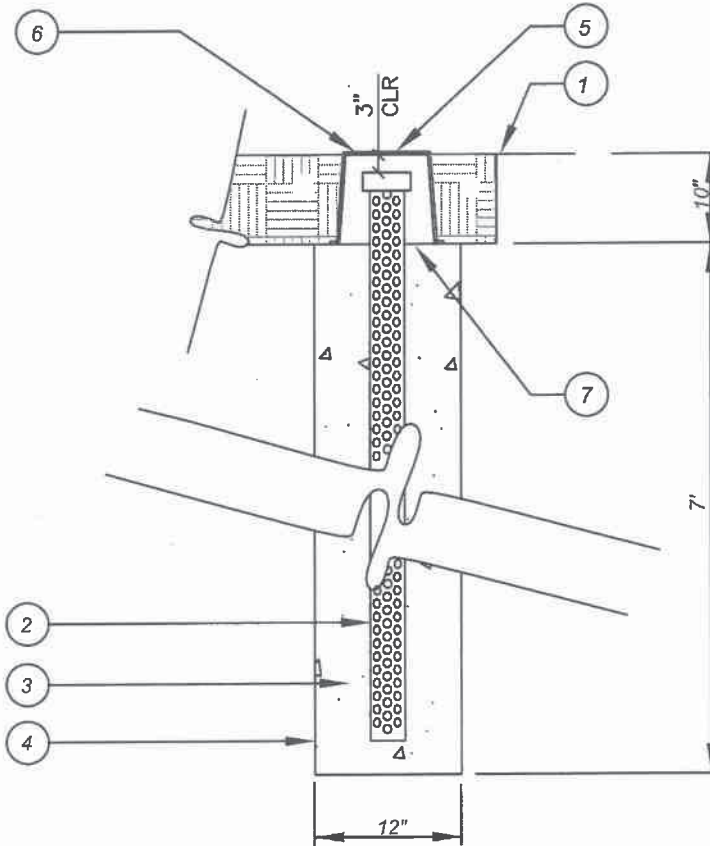

**LEGEND**

- ① FINISHED GRADE
- ② 4" PERFORATED PIPE W/ DRAIN SOCK AND CAP AT TOP. ADD HOLES OPPOSITE SIDE.
- ③ 3/4" CRUSHED AGGREGATE (3/4" MIN, NO FINES)
- ④ SPUN BOUND FILTER WRAP FABRIC
- ⑤ 10" ROUND BOX WITH SS BOLT & CLIP
- ⑥ 2" HEAT STAMP "SUMP"
- ⑦ 1/4" STAINLESS STEEL WIRE MESH, TYPE 316

NOT TO SCALE

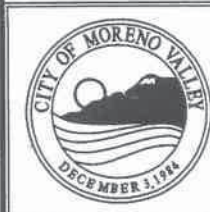

RECOMMENDED  
*[Signature]* 6/20/19  
 DIVISION MANAGER DATE  
 APPROVED:  
*M. W. W.* 7/30/19  
 PUBLIC WORKS DIRECTOR / DATE  
 CITY ENGINEER

**CITY OF MORENO VALLEY**  
 PARKS AND COMMUNITY SERVICES DEPARTMENT

**TREE WELL SUMP**

STANDARD PLAN  
**MVLI-565-0**

SHEET 1 OF 1

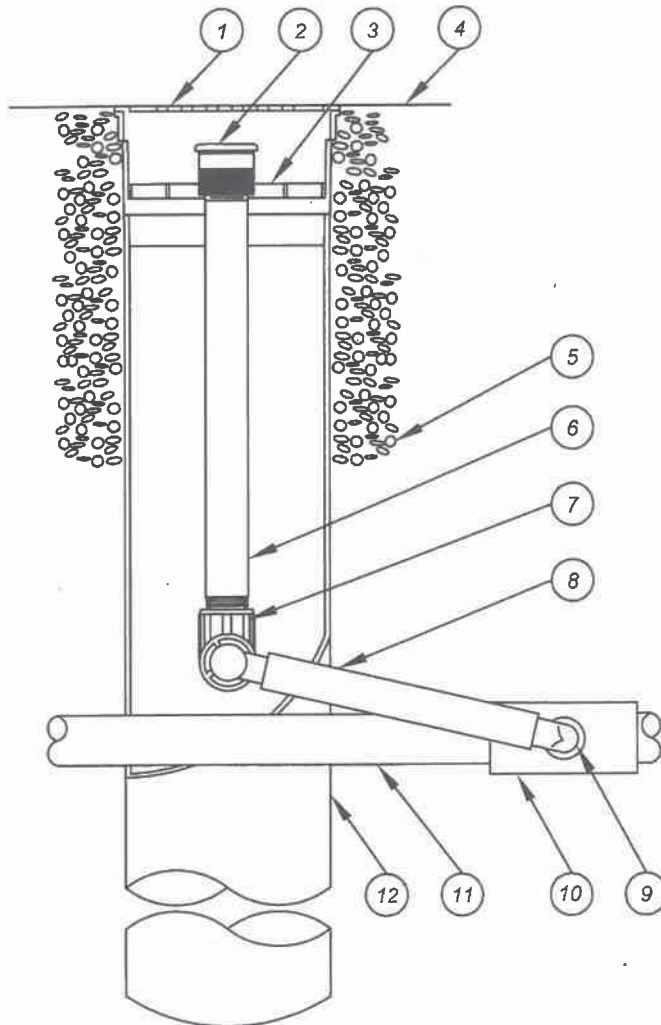

- |  |   |
|--|---|
| <p>1 4-INCH GRATE (INCLUDED)</p> <p>2 BUBBLER: RAIN BIRD 1402 0.50 GPM OR AS REQUESTED (INCLUDED)</p> <p>3 ROOT WATERING SYSTEM:<br/>RAIN BIRD RWS-BCG02 OR AS SPECIFIED (INCLUDES 1402 0.50 GPM BUBBLER WITH RISER, GRATE, SWING ASSEMBLY, 1/2" MALE NPT INLET, CHECK VALVE, AND BASKET CANISTER)</p> <p>4 FINISH GRADE</p> <p>5 3/4" ROCK AND RWS SAND SOCK (RWS-SOCK)</p> | <p>6 1/2-INCH PVC SCH 80 NIPPLE (INCLUDED)</p> <p>7 1/2-INCH 90-DEGREE ELBOW (INCLUDED)</p> <p>8 12-INCH SWING ASSEMBLY (INCLUDED)</p> <p>9 1/2-INCH MALE NPT INLET (INCLUDED)</p> <p>10 PVC SCH 40 TEE OR ELL</p> <p>11 LATERAL PIPE</p> <p>12 4-INCH BASKET WEAVE CANISTER (INCLUDED)</p> |
|--|---|

NOT TO SCALE



RECOMMENDED: *[Signature]* 6/20/19  
 DIVISION MANAGER DATE

APPROVED: *[Signature]* 7/30/19  
 PUBLIC WORKS DIRECTOR / DATE  
 CITY ENGINEER

# CITY OF MORENO VALLEY

PARKS AND COMMUNITY SERVICES DEPARTMENT

## RAINBIRD RWS - BCG02 ROOT WATERING SYSTEM

STANDARD PLAN

**MVLI-566-0**

SHEET 1 OF 1

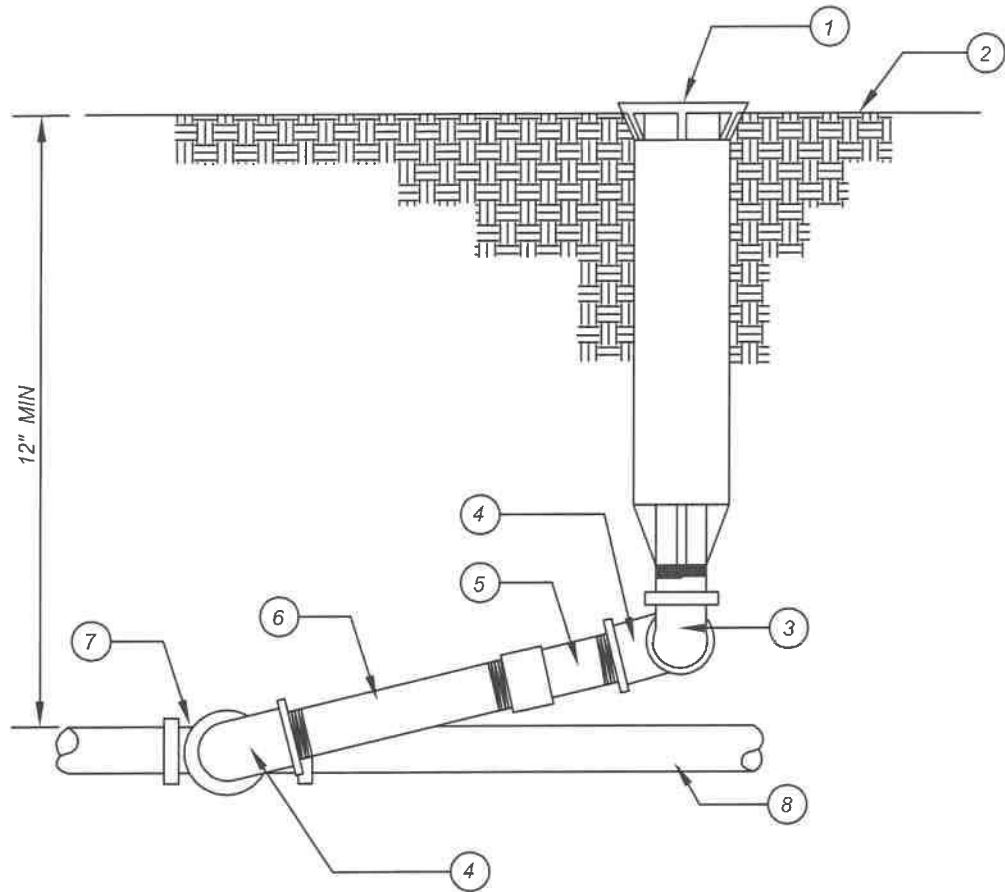

**LEGEND:**

- ① POP-UP HEAD
- ② FINISH GRADE
- ③ SCH 40 PVC 90 DEGREE STREET ELL (MIPT x FIPT)
- ④ MARLEX 90 DEGREE STREET ELL (MIPT x FIPT)
- ⑤ ANTI-DRAIN VALVE-ALL DOWN SLOPE HEADS-IF NOT INSTALLED IN HEADS
- ⑥ SCH 80 PVC NIPPLE (6" LONG)
- ⑦ SCH 40 PVC TEE (S x S x T TEE OR S x T 90° ELL)
- ⑧ NON-PRESSURE LATERAL LINE

**NOTES:**

- 1) LOCATE HEAD 4" FROM HARDSCAPING IN TURF AREAS - 8" MINIMUM IN PLANTER AREAS. (THESE MINIMUMS MAY BE INCREASED PER SPECIFICATIONS).
- 2) USE TEFLON TAPE ON ALL MALE THREADS.

NOT TO SCALE

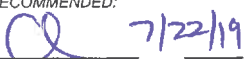
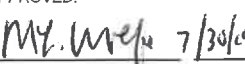
	RECOMMENDED:  DIVISION MANAGER      DATE	<h2 style="margin: 0;">CITY OF MORENO VALLEY</h2> <p style="margin: 0;">PUBLIC WORKS DEPARTMENT - SPECIAL DISTRICTS DIVISION</p>	STANDARD PLAN <h3 style="margin: 0;">MVLI-570A-0</h3>
	APPROVED:  PUBLIC WORKS DIRECTOR / DATE CITY ENGINEER	<h3 style="margin: 0;">6" POP-UP SPRAY HEAD</h3>	SHEET 1 OF 3

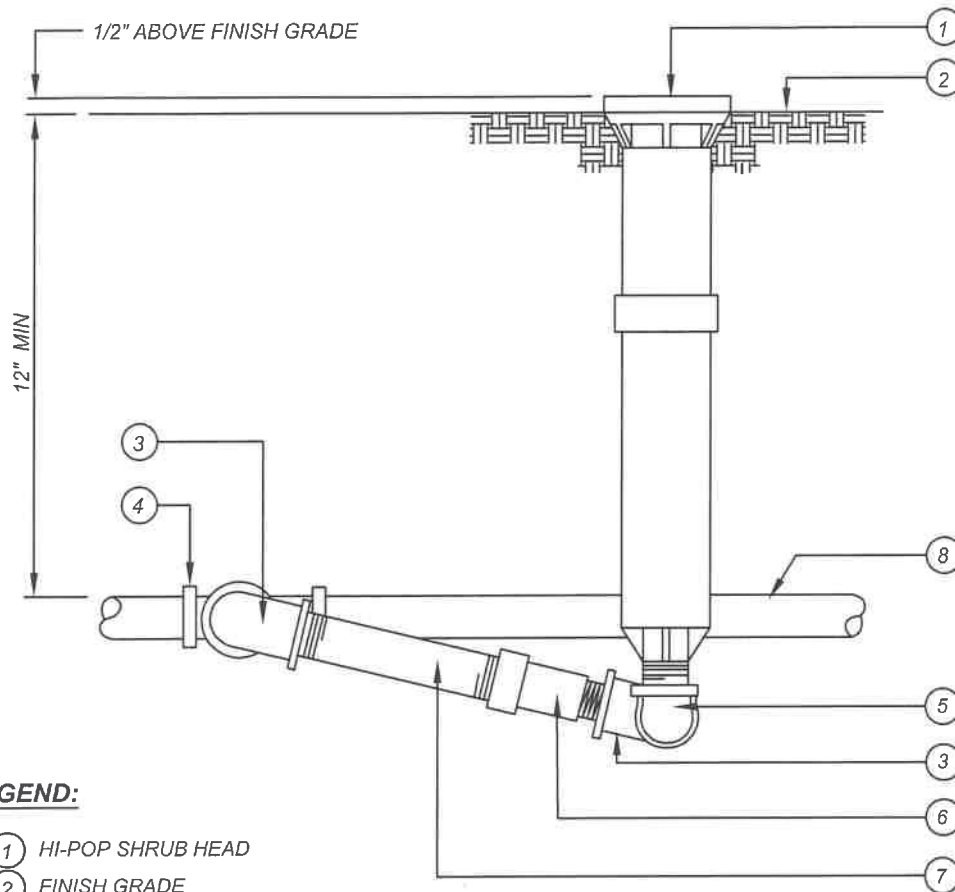

**LEGEND:**

- ① HI-POP SHRUB HEAD
- ② FINISH GRADE
- ③ MARLEX 90 DEGREE STREET ELL
- ④ SCH 40 PVC TEE (S x S x T)
- ⑤ SCH 40 PVC 90 DEGREE STREET ELL (MIPT x FIPT)
- ⑥ ANTI-DRAIN VALVE-ALL DOWN SLOPE HEADS-IF NOT INSTALLED IN HEAD
- ⑦ SCH 80 PVC NIPPLE - 12" LONG
- ⑧ NON-PRESSURE LATERAL LINE

**NOTES:**

- 1) LOCATE HEAD 4" FROM HARDSCAPING IN TURF AREAS - 8" MINIMUM IN PLANTER AREAS. (THESE MINIMUMS MAY BE INCREASED PER SPEC.)
- 2) USE TEFLON TAPE ON ALL MALE THREADS.

NOT TO SCALE



RECOMMENDED:  
*[Signature]* 7/22/19  
 DIVISION MANAGER DATE  
 APPROVED:  
*[Signature]* 7/30/19  
 PUBLIC WORKS DIRECTOR / DATE  
 CITY ENGINEER

**CITY OF MORENO VALLEY**  
 PUBLIC WORKS DEPARTMENT - SPECIAL DISTRICTS DIVISION

**12" POP-UP SPRAY HEAD**

STANDARD PLAN  
**MVLI-570B-0**

SHEET 2 OF 3



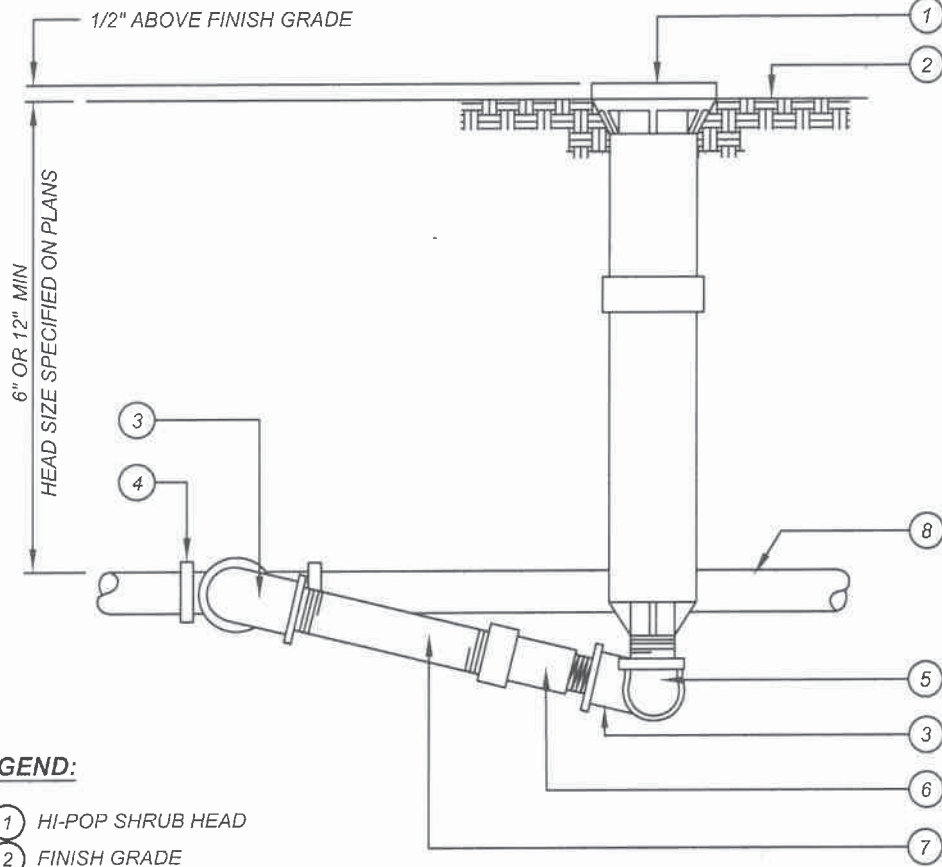

**LEGEND:**



- 1 HI-POP SHRUB HEAD
- 2 FINISH GRADE
- 3 MARLEX 90 DEGREE STREET ELL
- 4 SCH 40 PVC TEE (S x S x T)
- 5 SCH 40 PVC 90 DEGREE STREET ELL (MIPT x FIPT)
- 6 ANTI-DRAIN VALVE-ALL DOWN SLOPE HEADS - IF NOT INSTALLED IN HEAD
- 7 SCH 80 PVC NIPPLE - LENGTH EQUAL TO SPRINKLER HEIGHT
- 8 NON-PRESSURE LATERAL LINE

**NOTES:**

- 1) LOCATE HEAD 2" FROM HARDSCAPING IN TURF AREAS - 4" MINIMUM IN PLANTER AREAS (THESE MINIMUMS MAY BE INCREASED PER SPEC.)
- 2) USE TEFLON TAPE ON ALL MALE THREADS
- 3) PRE-MANUFACTURED SWING ASSEMBLIES MAY BE SUBSTITUTED WITH AGENCY APPROVAL

NOT TO SCALE



RECOMMENDED:  
  
 DIVISION MANAGER DATE  
 APPROVED:  
  
 PUBLIC WORKS DIRECTOR / DATE  
 CITY ENGINEER

**CITY OF MORENO VALLEY**  
 PARKS AND COMMUNITY SERVICES DEPARTMENT

**6" OR 12" POP-UP SPRAY HEAD**

STANDARD PLAN  
**MVLI-570C-0**

SHEET 3 OF 3

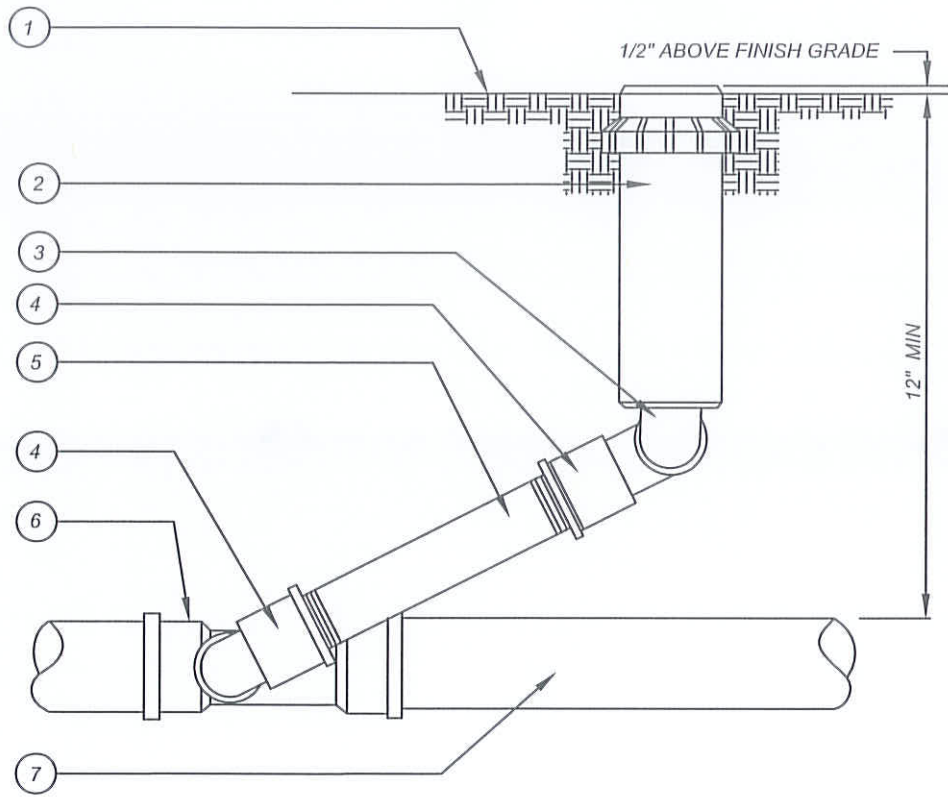



**LEGEND:**

- ① FINISH GRADE
- ② POP-UP GEARED ROTOR W/INTERNAL ANTI-DRAIN VALVES
- ③ 3/4" SCH 40 PVC 90 DEGREE STREET ELL (MIPT x FIPT)
- ④ 3/4" MARLEX 90 DEGREE STREET ELL (MIPT x FIPT)
- ⑤ 3/4" SCH 80 NIPPLE (LENGTH AS REQUIRED)
- ⑥ SCH 40 PVC TEE (S x S x T)
- ⑦ NON-PRESSURE LATERAL LINE

**NOTES:**

- 1) USE 12" HIGH-POPS IN SHRUB AREAS.
- 2) ALIGN HEADS PERPENDICULAR WITH ANGLE OF SLOPE.
- 3) ADD ANTI-DRAIN VALVES ON 3/4" NIPPLE ON DOWN SLOPE ROTORS IF NOT FITTED IN HEAD BY MFG.
- 4) LOCATE HEAD 6" FROM HARDSCAPE IN TURF AREAS - 12" IN PLANTER AREAS.  
(THESE MINIMUMS MAY BE INCREASED PER SPECIFICATIONS).

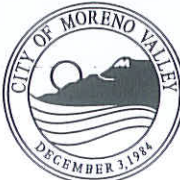
NOT TO SCALE

	RECOMMENDED:  1-16-14 DIVISION MANAGER      DATE	<h2 style="margin: 0;">CITY OF MORENO VALLEY</h2> <p style="margin: 0;">FINANCIAL &amp; MANAGEMENT SERVICES DEPARTMENT - SPECIAL DISTRICTS DIVISION</p>	
	APPROVED:  1/29/14 PUBLIC WORKS DIRECTOR / DATE CITY ENGINEER	<h3 style="margin: 0;">POP-UP ROTARY HEAD</h3>	STANDARD PLAN <h3 style="margin: 0;">MVLI-571A-0</h3>
	SHEET 1 OF 2		

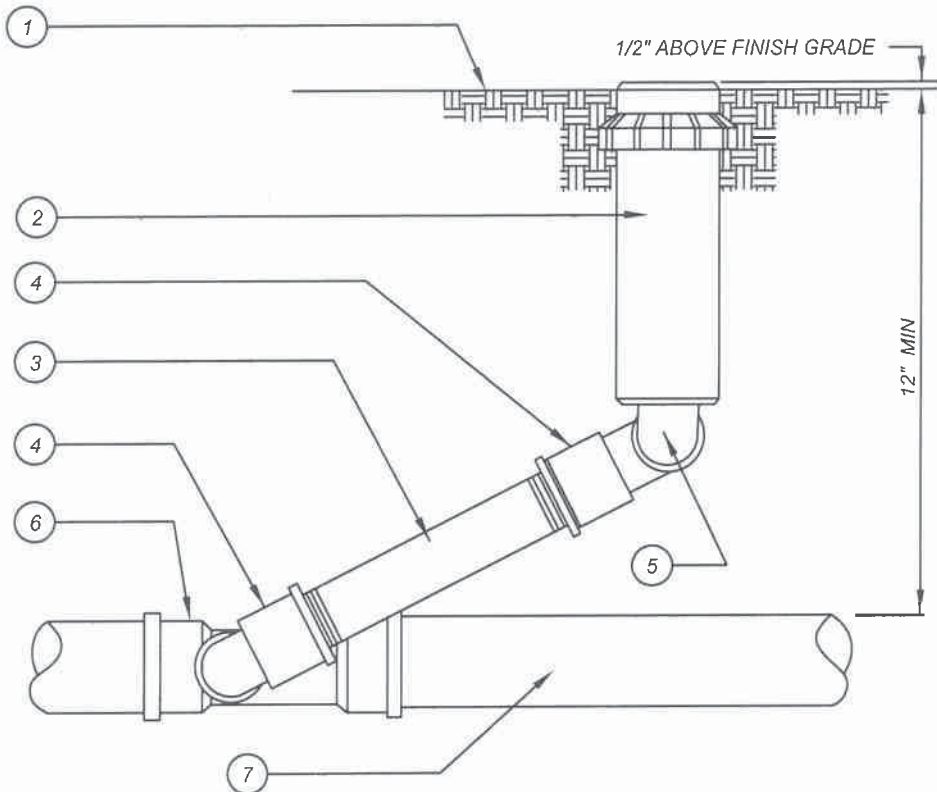



**LEGEND:**

- 1) FINISH GRADE
- 2) POP-UP GEARED ROTOR W/INTERNAL ANTI-DRAIN VALVES. SS RISERS ARE REQUIRED ON ROTORS UNDER 12"
- 3) SCH 80 PVC NIPPLE - LENGTH EQUAL TO ROTOR HEIGHT
- 4) MARLEX 90 DEGREE STREET ELL
- 5) SCH 40 90 DEGREE STREET ELL
- 6) SCH 40 PVC TEE (S x S x T)
- 7) NON-PRESSURE LATERAL LINE

**NOTES:**

- 1) USE 12" HIGH-POPS IN SHRUB AREAS
- 2) ALIGN HEADS PERPENDICULAR WITH ANGLE OF SLOPE
- 3) LOCATE HEAD 2" FROM HARDSCAPE IN TURF AREAS - 6" IN PLANTER AREAS  
(THESE MINIMUMS MAY BE INCREASED PER SPECIFICATIONS)
- 4) USE TEFLON TAPE ON ALL MALE THREADS
- 5) PRE-MANUFACTURED SWING ASSEMBLIES MAY BE SUBMITTED WITH AGENCY APPROVAL

NOT TO SCALE

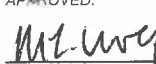
	RECOMMENDED:  DIVISION MANAGER      DATE 9/24/19	<b>CITY OF MORENO VALLEY</b> PARKS AND COMMUNITY SERVICES DEPARTMENT	STANDARD PLAN
	APPROVED:  PUBLIC WORKS DIRECTOR / DATE 10/1/19 CITY ENGINEER		<b>POP-UP ROTARY HEAD</b>

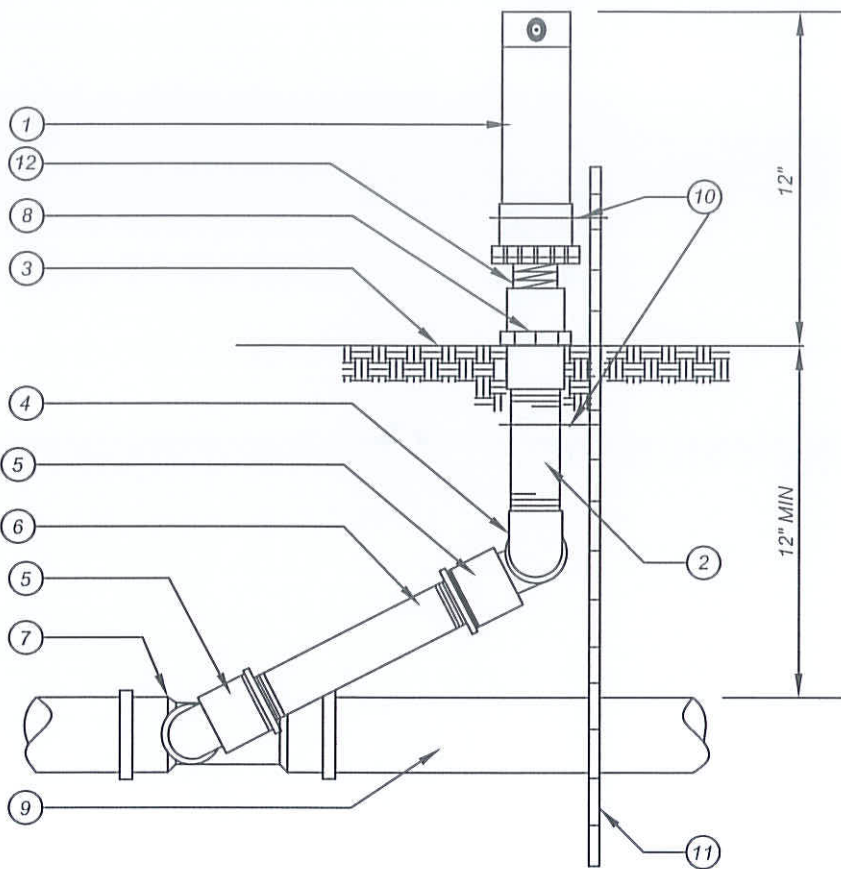

**LEGEND:**

- ① GEARED SHRUB ROTOR
- ② SCH 80 3/4" PVC RISER (LENGTH AS REQUIRED) (REBAR STAKED WITH 2 STAINLESS STEEL CLAMPS IF 6" OR MORE EXPOSURE)
- ③ FINISH GRADE (ALIGN HEAD PERPENDICULAR WITH ANGLE OF SLOPE)
- ④ 3/4" SCH 40 PVC 90 DEGREE ELL (FIPT X FIPT)
- ⑤ 3/4" MARLEX 90 DEGREE STREET ELL (MIPT X FIPT)
- ⑥ 3/4" x 8" SCH 80 NIPPLE
- ⑦ SCH 40 PVC TEE (S x S x T)
- ⑧ ANTI DRAIN VALVE ON DOWN SLOPE ROTORS IF NOT FITTED IN BY MFG.
- ⑨ NON-PRESSURE LATERAL LINE
- ⑩ STAINLESS STEEL SCREW, CLAMP MIN. (2) PLACES
- ⑪ No 4 REBAR STAKE (24" LONG)
- ⑫ SCH 80 CLOSE NIPPLE

NOT TO SCALE

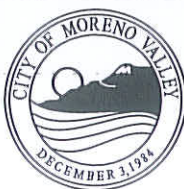

RECOMMENDED:  
 COS 1-16-14  
 DIVISION MANAGER DATE

APPROVED:  
 [Signature] 1/29/14  
 PUBLIC WORKS DIRECTOR / DATE  
 CITY ENGINEER

**CITY OF MORENO VALLEY**  
 FINANCIAL & MANAGEMENT SERVICES DEPARTMENT - SPECIAL DISTRICTS DIVISION

**ROTOR INSTALLATION ON  
 FIXED RISER**

STANDARD PLAN  
**MVLI-572-0**

SHEET 1 OF 1



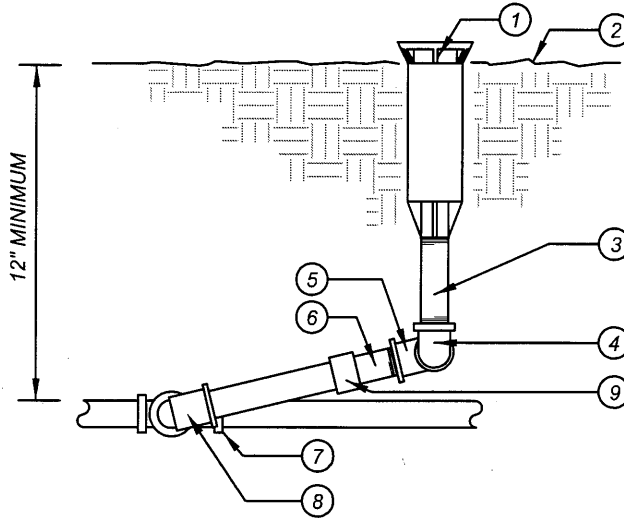



**LEGEND:**

- ① RAINBIRD 1800 SAM-PRS POP -UP HEAD WITH PURPLE RUBBER COVER (AS REQUIRED) 2" ABOVE GRADE IN SHRUB AREAS & 1" ABOVE GRADE IN TURF. RECLAIMED WATER SYSTEMS REQUIRE INTEGRATED PURPLE BODY CAP (NO PURPLE COVERS).
- ② FINISH GRADE
- ③ SCH 80 PVC NIPPLE LENGTH AS NECESSARY
- ④ SCH 40 PVC T x T 90 DEGREE ELBOW
- ⑤ MARLEX 90 DEGREE STREET ELBOW
- ⑥ SCH 80 PVC NIPPLE (6" LONG)
- ⑦ NON-PRESSURE LATERAL LINE & TEE FITTING
- ⑧ MARLEX 90 DEGREE ELBOW
- ⑨ ANTI-DRAIN VALVE-ALL DOWN SLOPE HEADS

**NOTES:**

- 1.) LOCATE HEAD 2" FROM WALKS, CURBS, HARDSCAPING, MOW STRIPS.
- 2.) LOCATE HEAD 6" FROM ALL STRUCTURES.
- 3.) USE TEFLON TAPE ON ALL MALE THREADS.
- 4.) PRE-MOLDED SWING JOINTS MAY BE USED UPON APPROVAL.
- 5.) FLEX PIPE MAY BE UTILIZED AS SWING ASSEMBLY.

NOT TO SCALE

	RECOMMENDED:  DIVISION MANAGER      DATE	<h2 style="margin: 0;">CITY OF MORENO VALLEY</h2> <p style="margin: 0;">PARKS AND COMMUNITY SERVICES DEPARTMENT</p> <h3 style="margin: 0;">RAINBIRD 1800 SAM PRS POP UP SPRAY HEAD</h3>	STANDARD PLAN <b>MVLI-573-0</b>
	APPROVED:  PUBLIC WORKS DIRECTOR / DATE CITY ENGINEER		SHEET 1 OF 1

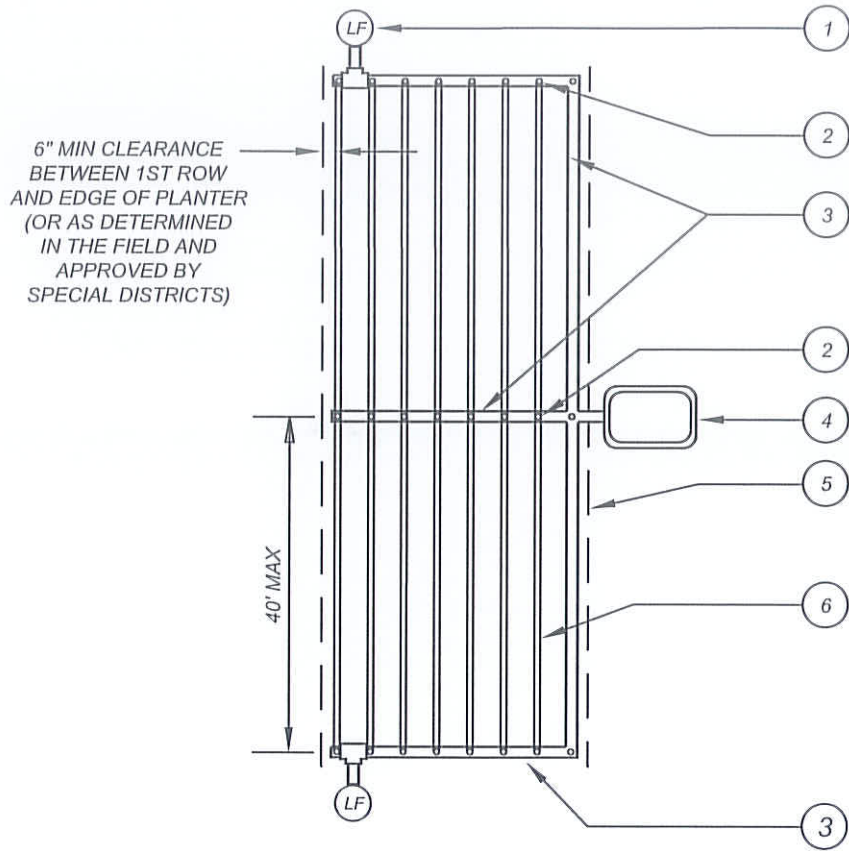

- ① MANUAL SHUT-OFF VALVE (REFER TO STANDARD MVLI-574G-0)
- ② DRIPPERLINE TO PVC CONNECTION (REFER TO STANDARD MVLI-574E-0)
- ③ LATERAL LINE (BURIED 12" MIN)
- ④ REMOTE CONTROL VALVE WITH FILTER AND PRESSURE REGULATING VALVE (REFER TO PLANS)
- ⑤ AREA PERIMETER
- ⑥ DRIPPERLINE TUBING LATERAL - BURIED 3" - 4" (SPACING AS SPECIFIED ON PLANS)

**NOTES:**

- 1.) SOIL STAPLE DRIPPERLINE TUBING AT 3' OC WITH NETAFIM TLS6.
- 2.) REFER TO STANDARD MVLI-574E-0 FOR DRIPPERLINE AND BELOW GROUND PVC CONNECTION.
- 3.) REFER TO STANDARD MVLI-574G-0 FOR MANUAL SHUT-OFF/FLUSH VALVE.

NOT TO SCALE

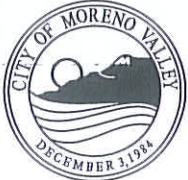
	RECOMMENDED: <i>COS</i> 1/16/14 <small>DIVISION MANAGER      DATE</small>	<h2 style="margin: 0;">CITY OF MORENO VALLEY</h2> <p style="margin: 0;">FINANCIAL &amp; MANAGEMENT SERVICES DEPARTMENT - SPECIAL DISTRICTS DIVISION</p>	<small>STANDARD PLAN</small> <b>MVLI-574A-0</b>
	APPROVED: <i>[Signature]</i> 1/29/14 <small>PUBLIC WORKS DIRECTOR / DATE</small> <small>CITY ENGINEER</small>	<h3 style="margin: 0;">DRIPPERLINE (WITH INTEGRATED CHECK VALVES) CENTER FEED LAYOUT</h3>	

6" MIN CLEARANCE  
BETWEEN 1ST ROW  
AND EDGE OF PLANTER  
(OR AS DETERMINED  
IN THE FIELD AND  
APPROVED BY  
PARKS AND  
COMMUNITY SERVICES)

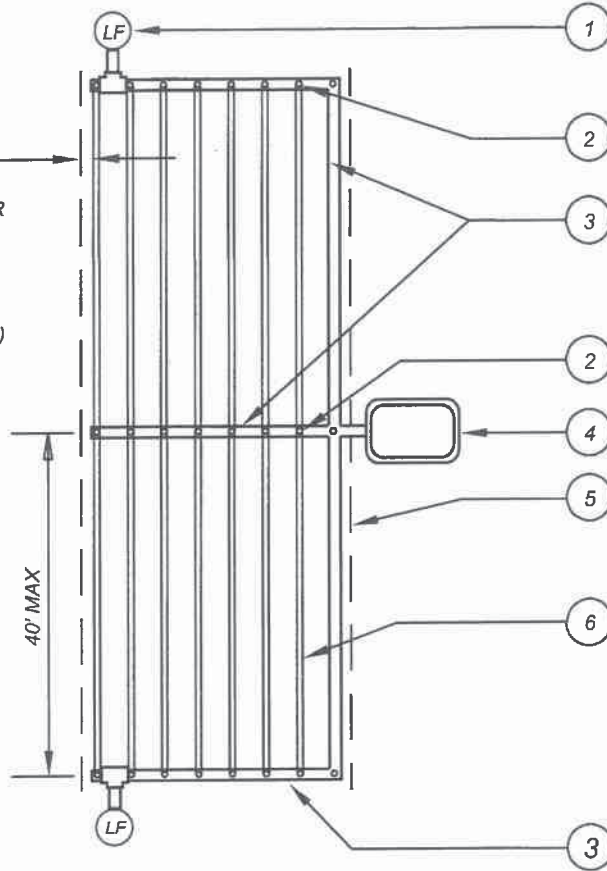



- 1) MANUAL SHUT-OFF VALVE (REFER TO STANDARD MVLI-574H)
- 2) DRIPPERLINE TO PVC CONNECTION (REFER TO STANDARD MVLI-574F) OR MANUFACTURER'S PRE-MADE DRIPLINE HEADER
- 3) LATERAL LINE (BURIED 12" MIN)
- 4) REMOTE CONTROL VALVE WITH T58S-70-76 BALL VALVE, FILTER AND PRESSURE REGULATING VALVE (REFER TO PLANS)
- 5) AREA PERIMETER
- 6) DRIPPERLINE TUBING LATERAL (AS SPECIFIED) - BURIED 2" (SPACING AS SPECIFIED ON PLANS)

**NOTES:**

- 1.) SOIL STAPLE DRIPPERLINE TUBING AT 3' OC WITH RAINBIRD STAKE WITH BEND
- 2.) REFER TO STANDARD MVLI-574F-0 FOR DRIPPERLINE AND BELOW GROUND PVC CONNECTION
- 3.) REFER TO STANDARD MVLI-574H-0 FOR MANUAL SHUT-OFF/FLUSH VALVE

NOT TO SCALE

	RECOMMENDED:  DIVISION MANAGER	 DATE	<h2 style="margin: 0;">CITY OF MORENO VALLEY</h2> <p style="margin: 0;">PARKS AND COMMUNITY SERVICES DEPARTMENT</p>	STANDARD PLAN <h3 style="margin: 0;">MVLI-574B-0</h3>
	APPROVED:  PUBLIC WORKS DIRECTOR / DATE CITY ENGINEER	<h3 style="margin: 0;">DRIPPERLINE (WITH INTEGRATED CHECK VALVES) CENTER FEED LAYOUT</h3>		SHEET 2 OF 12

6" MIN CLEARANCE  
BETWEEN 1ST ROW  
AND EDGE OF PLANTER  
(OR AS DETERMINED  
IN THE FIELD AND  
APPROVED BY  
SPECIAL DISTRICTS)

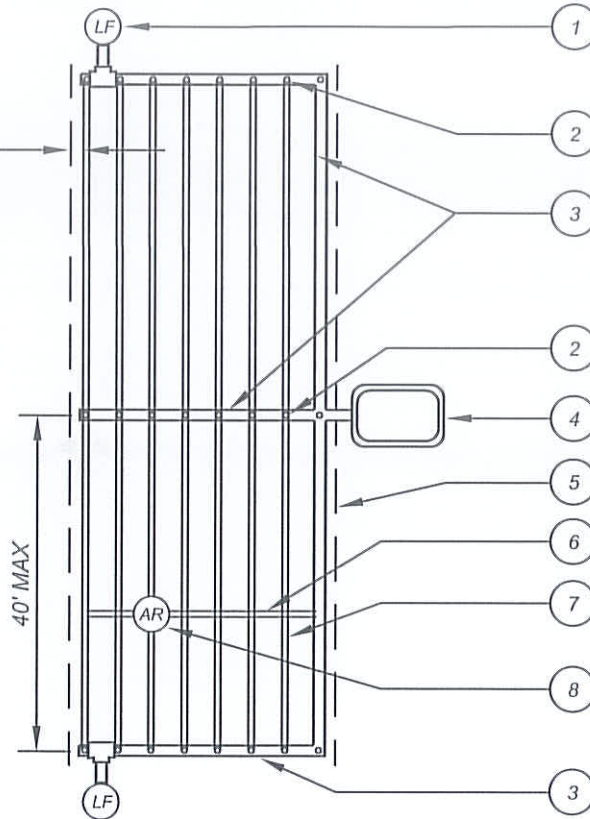



- ① AUTOMATIC FLUSH VALVE (REFER TO STANDARD MVLI-574I-0)
- ② DRIPPERLINE TO PVC CONNECTION (REFER TO STANDARD MVLI-574E-0)
- ③ LATERAL LINE (BURIED 12" MIN)
- ④ REMOTE CONTROL VALVE WITH FILTER AND PRESSURE REGULATING VALVE (REFER TO PLANS)
- ⑤ AREA PERIMETER
- ⑥ SOLID TUBING WITHOUT EMITTERS
- ⑦ DRIPPERLINE TUBING LATERAL - BURIED 3"-4"  
(SPACING AS SPECIFIED ON PLANS)
- ⑧ AIR/VACUUM RELIEF VALVE (REFER TO STANDARD MVLI-574K-0)

**NOTES:**

- 1.) SOIL STAPLE DRIPPERLINE TUBING AT 3' OC WITH NETAFIM TLS6.
- 2.) REFER TO STANDARD MVLI-574E-0 FOR DRIPPERLINE AND BELOW GROUND PVC CONNECTION.
- 3.) REFER TO STANDARD MVLI-574I-0 FOR AUTOMATIC FLUSH VALVE.
- 4.) REFER TO STANDARD MVLI-574K-0 FOR AIR/VACUUM RELIEF VALVE.

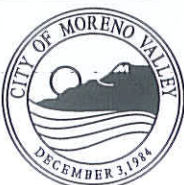
NOT TO SCALE



RECOMMENDED:  
 1-16-14  
 DIVISION MANAGER DATE  
 APPROVED:  
 1/29/14  
 PUBLIC WORKS DIRECTOR/ DATE  
 CITY ENGINEER

**CITY OF MORENO VALLEY**  
 FINANCIAL & MANAGEMENT SERVICES DEPARTMENT - SPECIAL DISTRICTS DIVISION

**DRIPPERLINE  
 (RECYCLED WATER SYSTEMS)  
 CENTER FEED LAYOUT**

STANDARD PLAN  
**MVLI-574C-0**  
 SHEET 3 OF 12



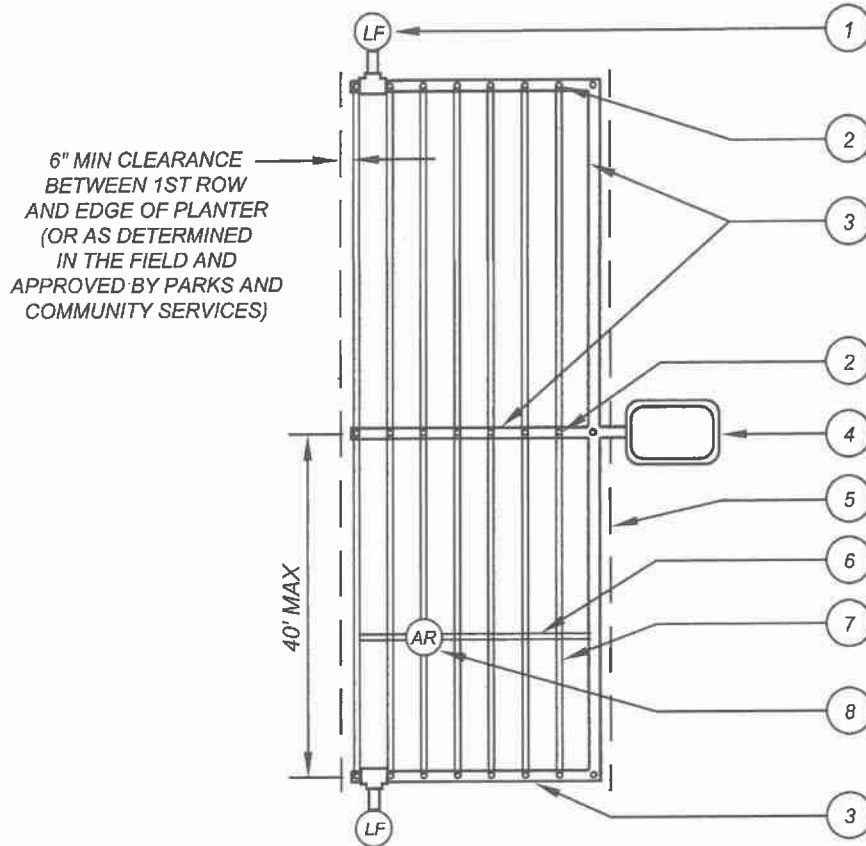

- ① AUTOMATIC FLUSH VALVE (REFER TO STANDARD MVLI-574J)
- ② DRIPPERLINE TO PVC CONNECTION (REFER TO STANDARD MVLI-574F) OR MANUFACTURER'S PRE-MADE DRIPLINE HEADER
- ③ LATERAL LINE (BURIED 12" MIN)
- ④ REMOTE CONTROL VALVE WITH FILTER AND PRESSURE REGULATING VALVE (REFER TO PLANS)
- ⑤ AREA PERIMETER
- ⑥ SOLID TUBING WITHOUT EMITTERS
- ⑦ DRIPPERLINE TUBING LATERAL - BURIED 2" (SPACING AS SPECIFIED ON PLANS)
- ⑧ AIR/VACUUM RELIEF VALVE (REFER TO STANDARD MVLI-574L)

**NOTES:**

- 1.) SOIL STAPLE DRIPPERLINE TUBING AT 3' OC WITH NETAFIM TLS6
- 2.) REFER TO STANDARD MVLI-574F FOR DRIPPERLINE AND BELOW GROUND PVC CONNECTION
- 3.) REFER TO STANDARD MVLI-574J FOR AUTOMATIC FLUSH VALVE
- 4.) REFER TO STANDARD MVLI-574L FOR AIR/VACUUM RELIEF VALVE

NOT TO SCALE

	RECOMMENDED: <i>[Signature]</i> DIVISION MANAGER DATE: 6/29/19	<h2 style="margin: 0;">CITY OF MORENO VALLEY</h2> <p style="margin: 0;">PARKS AND COMMUNITY SERVICES DEPARTMENT</p>	STANDARD PLAN <b>MVLI-574D-0</b>
	APPROVED: <i>[Signature]</i> PUBLIC WORKS DIRECTOR / CITY ENGINEER DATE: 7/30/19	<h3 style="margin: 0;">DRIPPERLINE (RECYCLED WATER SYSTEMS) CENTER FEED LAYOUT</h3>	





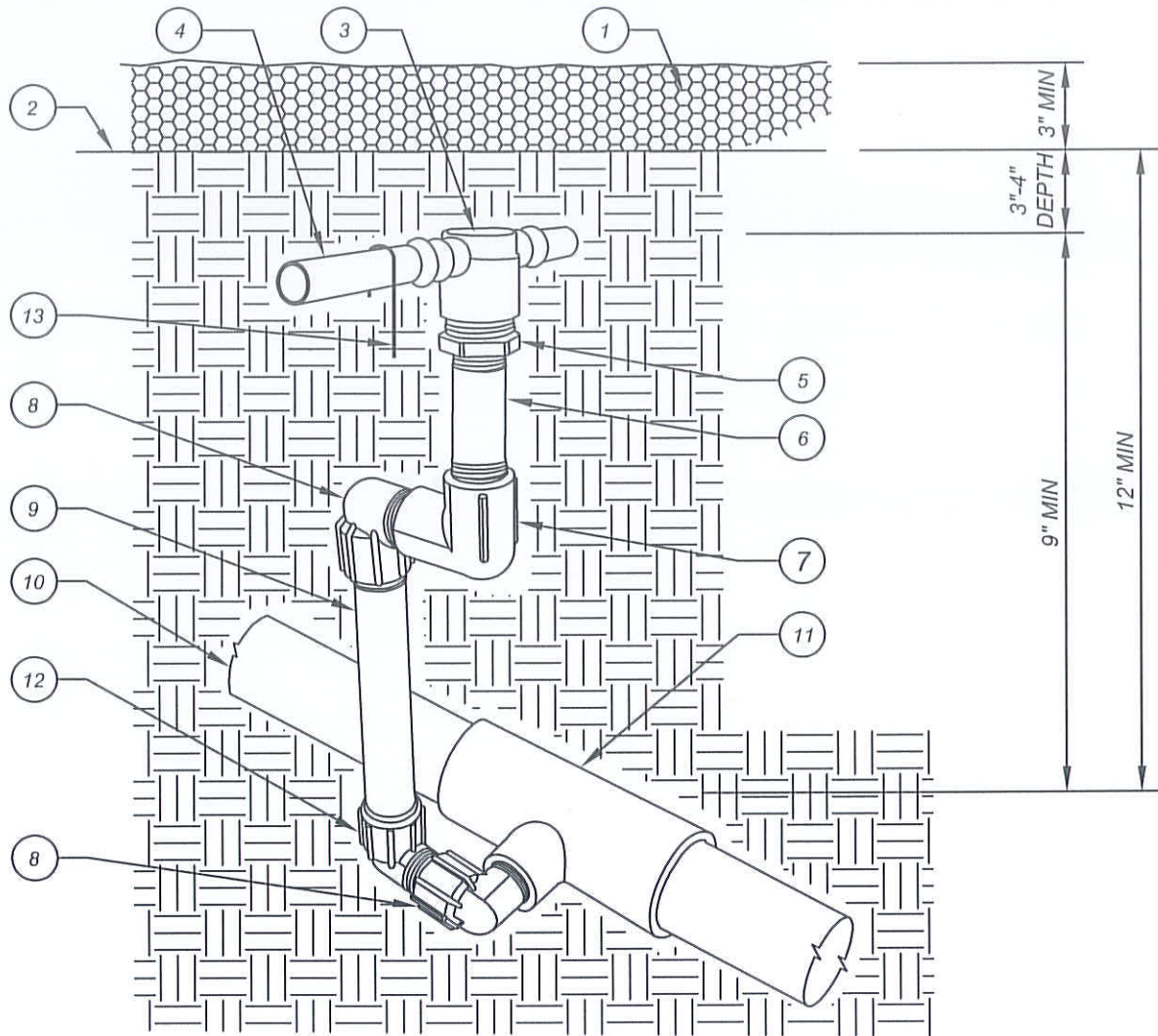

- |  |  |
|--|--|
| 1 BARK / MULCH PER SPECIFICATIONS.<br>3" THICK COVERAGE MINIMUM  | 7 1/2" PVC 90° ELL - FIPT x FIPT   |
| 2 FINISH GRADE OF SOIL SURFACE   | 8 1/2" MARLEX STREET ELL   |
| 3 DRIPPERLINE COMBINATION TEE (1/2" x 1/2" x 3/4" FIPT)<br>OR END CONNECTION AS APPLICABLE (1/2" PVC<br>90° ELL S x T WITH 1/2" MPT ADAPTER) | 9 1/2" x 6" SCH 80 NIPPLE  |
| 4 DRIPPERLINE TUBING PER PLANS OR SPECS.   | 10 3/4" MIN PVC LATERAL LINE PER PLANS   |
| 5 3/4" MIPT x 1/2" FIPT PVC REDUCER BUSHING  | 11 PVC TEE (S x S x T) - SIZE PER PLANS  |
| 6 1/2" x 4" SCH 80 NIPPLE  | 12 1/2" PVC STREET ELL   |
|  | 13 6" SOIL STABLE - PLACE APPROX EVERY 3' OF<br>TUBING, PLUS 2 ON EACH TEE, ELL OR CROSS |

NOTES: 1. ALL DRIPPERLINE FITTINGS SHALL BE OF THE SAME MANUFACTURE AS THE SPECIFIED DRIPPERLINE.  
2. USE TEFLON TAPE ON ALL PVC TO PVC CONNECTIONS.

NOT TO SCALE

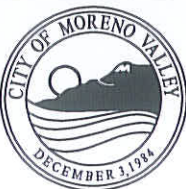

RECOMMENDED:

*[Signature]* 1/21/14  
DIVISION MANAGER DATE

APPROVED:

*[Signature]* 1/29/14  
PUBLIC WORKS DIRECTOR/ DATE  
CITY ENGINEER

## CITY OF MORENO VALLEY

PARKS AND COMMUNITY SERVICES DEPARTMENT

### PVC PIPE WITH SWING-JOINT CONNECTION TO DRIPPERLINE

STANDARD PLAN

**MVLI-574F-0**

SHEET 6 OF 12

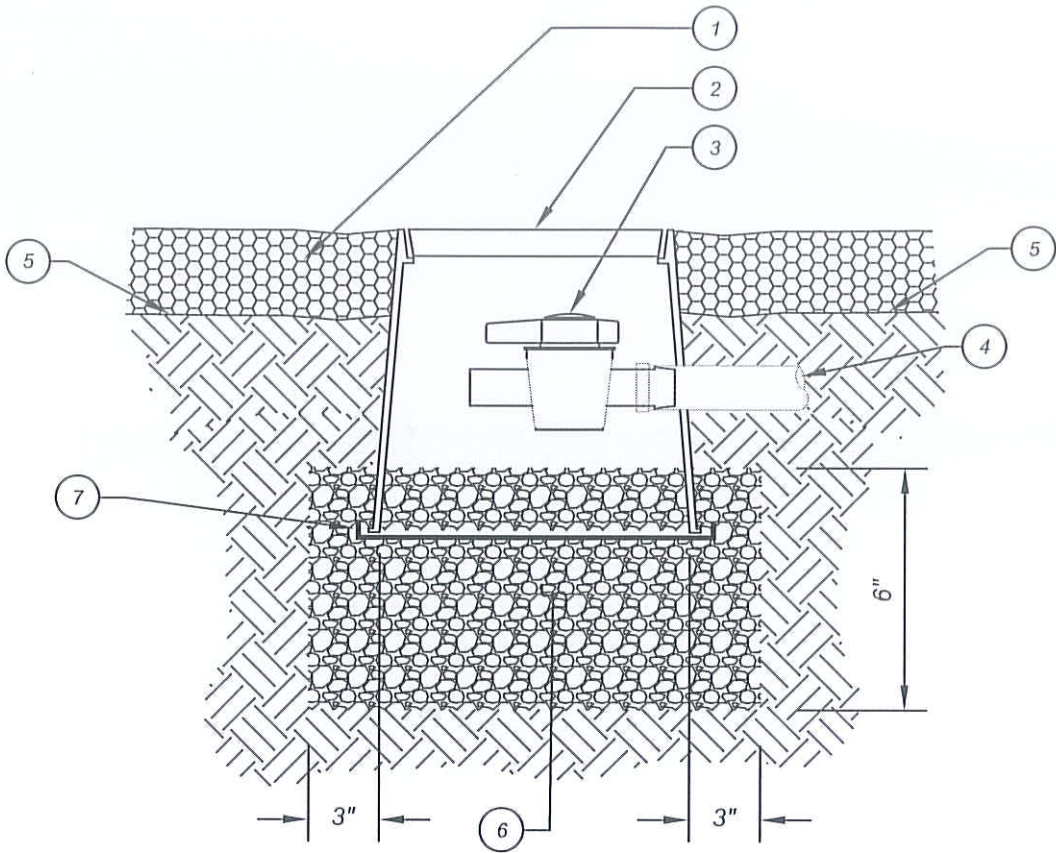

- ① FINISH SURFACE OF MULCH (3" THICK)
- ② 6" ROUND VALVE BOX. SEE NOTE BELOW
- ③ MANUAL SHUT-OFF VALVE (INS x INS)
- ④ DRIPPERLINE MANIFOLD CONNECTION
- ⑤ SOIL SURFACE FINISH GRADE, 3"-4" COVER OVER PIPE
- ⑥ 3/4" GRAVEL SUMP
- ⑦ 1/4" GALVANIZED WIRE MESH

**NOTE:**

TOP OF VALVE BOX TO BE INSTALLED 3" ABOVE FINISH GRADE IN PLANTER AREAS, AND EVEN WITH FINISH SURFACE OF MULCH.

NOT TO SCALE

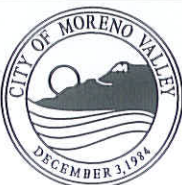

RECOMMENDED:  
 1.16.14  
 DIVISION MANAGER DATE

APPROVED:  
 1/29/14  
 PUBLIC WORKS DIRECTOR / DATE  
 CITY ENGINEER

**CITY OF MORENO VALLEY**  
 FINANCIAL & MANAGEMENT SERVICES DEPARTMENT - SPECIAL DISTRICTS DIVISION

**MANUAL SHUT-OFF / FLUSH VALVE  
 (FOR DRIPPERLINE)**

STANDARD PLAN  
**MVLI-574G-0**

SHEET 7 OF 12



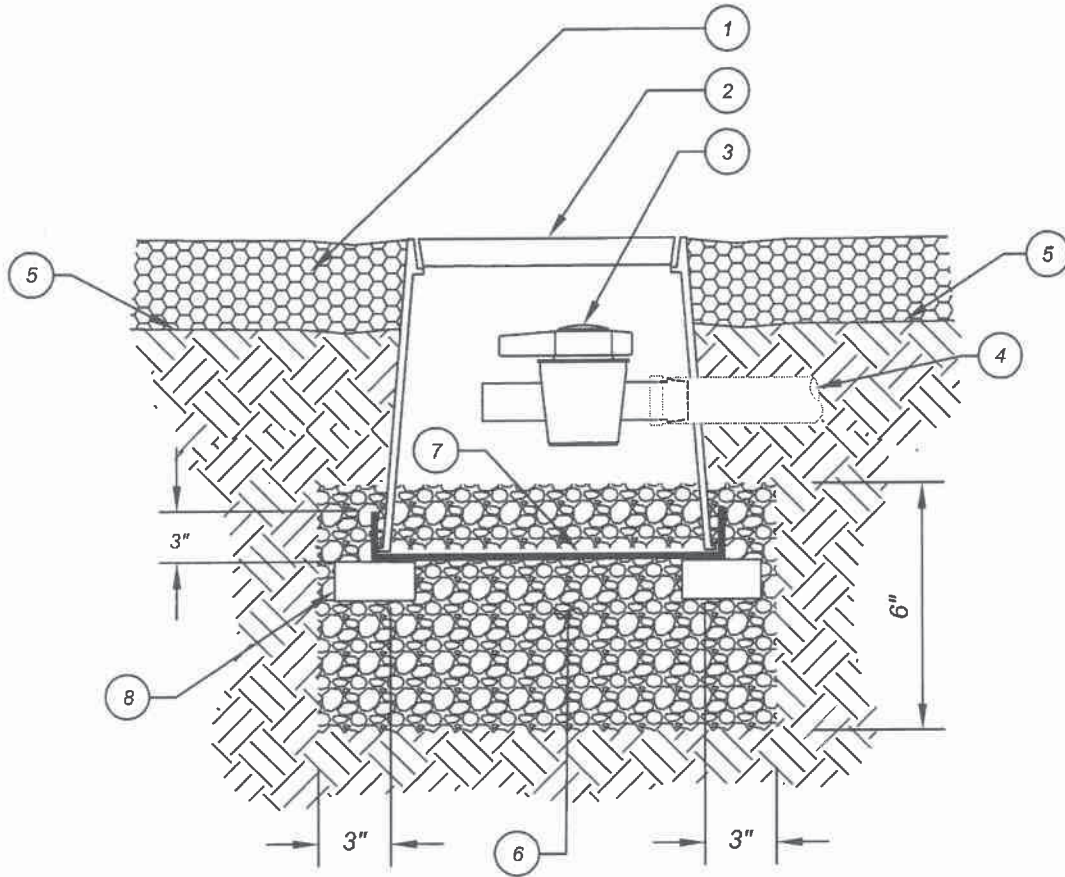



- 1 FINISH SURFACE OF MULCH (3" THICK)
- 2 10" ROUND VALVE BOX WITH SS BOLT AND WASHER. SEE NOTE BELOW
- 3 MANUAL SHUT-OFF VALVE (1/2" x 1/2")
- 4 DRIPPERLINE MANIFOLD CONNECTION
- 5 SOIL SURFACE FINISH GRADE, 3"-4" COVER OVER PIPE
- 6 3/4" GRAVEL SUMP
- 7 3/4" STAINLESS STEEL WIRE MESH, TYPE 316
- 8 CONCRETE PAVER SUPPORT (3 PER BOX)

**NOTE:**

TOP OF VALVE BOX TO BE INSTALLED 3" ABOVE FINISH GRADE IN PLANTER AREAS,  
AND EVEN WITH FINISH SURFACE OF MULCH

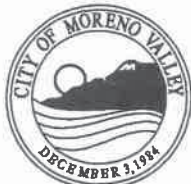
NOT TO SCALE

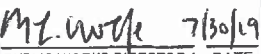
	RECOMMENDED:  DIVISION MANAGER      DATE	<h2 style="margin: 0;">CITY OF MORENO VALLEY</h2> <p style="margin: 0;">PARKS AND COMMUNITY SERVICES DEPARTMENT</p>	STANDARD PLAN <h3 style="margin: 0;">MVLI-574H-1</h3>
	APPROVED:  PUBLIC WORKS DIRECTOR / DATE CITY ENGINEER	<h3 style="margin: 0;">MANUAL SHUT-OFF / FLUSH VALVE (FOR DRIPPERLINE)</h3>	SHEET 8 OF 12

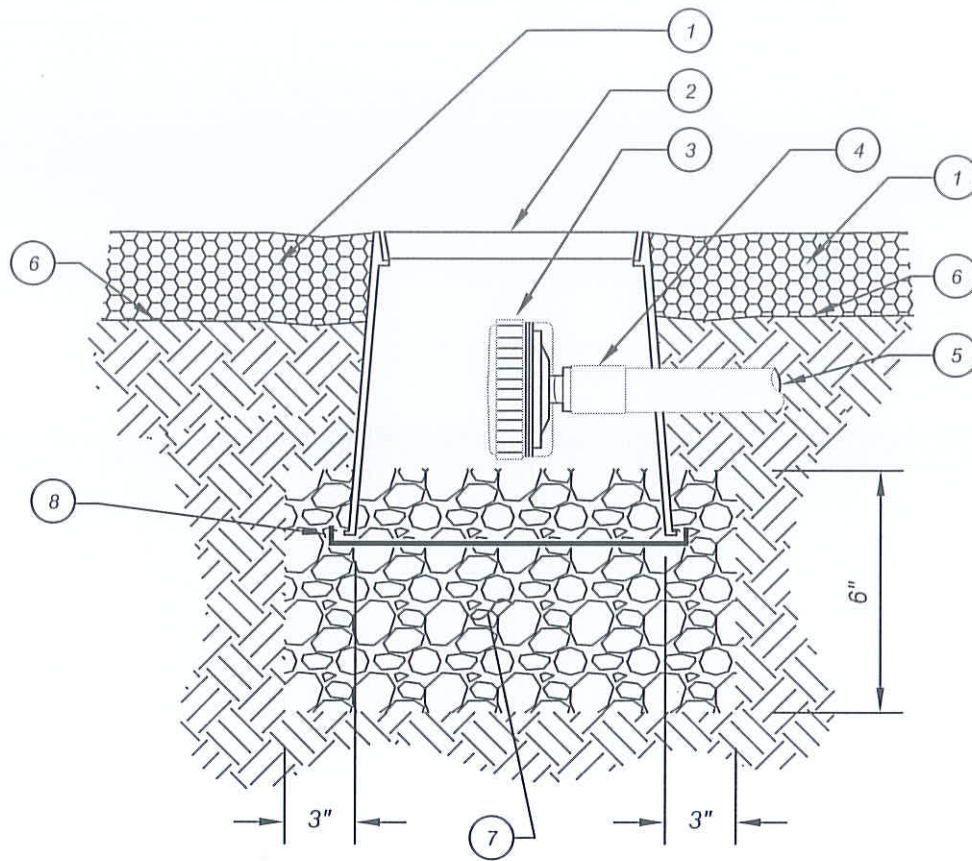

- 1 FINISH SURFACE OF MULCH (3" THICK)
- 2 6" ROUND VALVE BOX. SEE NOTE BELOW
- 3 AUTOMATIC FLUSH VALVE
- 4 1/2" PVC COUP (FIPT x FIPT) WITH 1/2" MPT ADAPTER
- 5 DRIPPERLINE MANIFOLD CONNECTION
- 6 FINISH GRADE OF SOIL SURFACE, 3" - 4" COVER OVER PIPE
- 7 3/4" GRAVEL SUMP
- 8 1/4" GALVANIZED WIRE MESH

**NOTE:**

TOP OF VALVE BOX TO BE INSTALLED 3" ABOVE FINISH GRADE IN PLANTER AREAS, AND EVEN WITH FINISH SURFACE OF MULCH.

NOT TO SCALE



RECOMMENDED:  
 COS 1.16.14  
 DIVISION MANAGER DATE  
 APPROVED:  
 [Signature] 1/29/14  
 PUBLIC WORKS DIRECTOR DATE  
 CITY ENGINEER

**CITY OF MORENO VALLEY**  
 FINANCIAL & MANAGEMENT SERVICES DEPARTMENT - SPECIAL DISTRICTS DIVISION

**AUTOMATIC FLUSH VALVE  
 (FOR DRIPPERLINE)**

STANDARD PLAN  
**MVLI-574I-0**

SHEET 9 OF 12

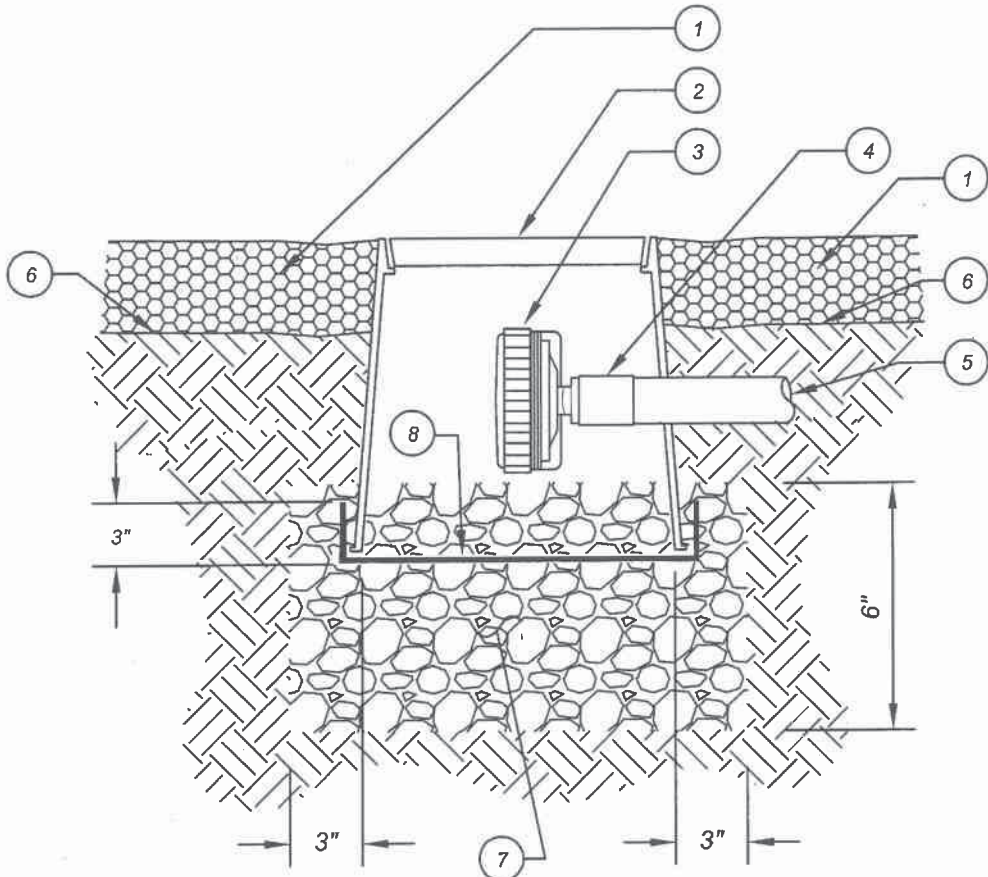

- ① FINISH SURFACE OF MULCH (3" THICK)
- ② 10" ROUND VALVE BOX WITH BOLT AND WASHER. SEE NOTE BELOW
- ③ AUTOMATIC FLUSH VALVE
- ④ 1/2" PVC COUP (FIPT x FIPT) WITH 1/2" MPT ADAPTER
- ⑤ DRIPPERLINE MANIFOLD CONNECTION
- ⑥ FINISH GRADE OF SOIL SURFACE, 3" - 4" COVER OVER PIPE
- ⑦ 3/4" GRAVEL SUMP
- ⑧ 1/4" STAINLESS STEEL WIRE MESH, TYPE 316

**NOTE:**

TOP OF VALVE BOX TO BE INSTALLED 3" ABOVE FINISH GRADE IN PLANTER AREAS, AND EVEN WITH FINISH SURFACE OF MULCH.

NOT TO SCALE

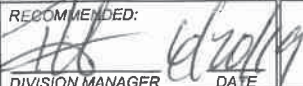
	RECOMMENDED:  DIVISION MANAGER      DATE	<h2 style="margin: 0;">CITY OF MORENO VALLEY</h2> <p style="margin: 0;">PARKS AND COMMUNITY SERVICES DEPARTMENT</p>	STANDARD PLAN <h3 style="margin: 0;">MVLI-574J-0</h3>
	APPROVED:  PUBLIC WORKS DIRECTOR / DATE CITY ENGINEER	<h3 style="margin: 0;">AUTOMATIC FLUSH VALVE (FOR DRIPPERLINE)</h3>	SHEET 10 OF 12



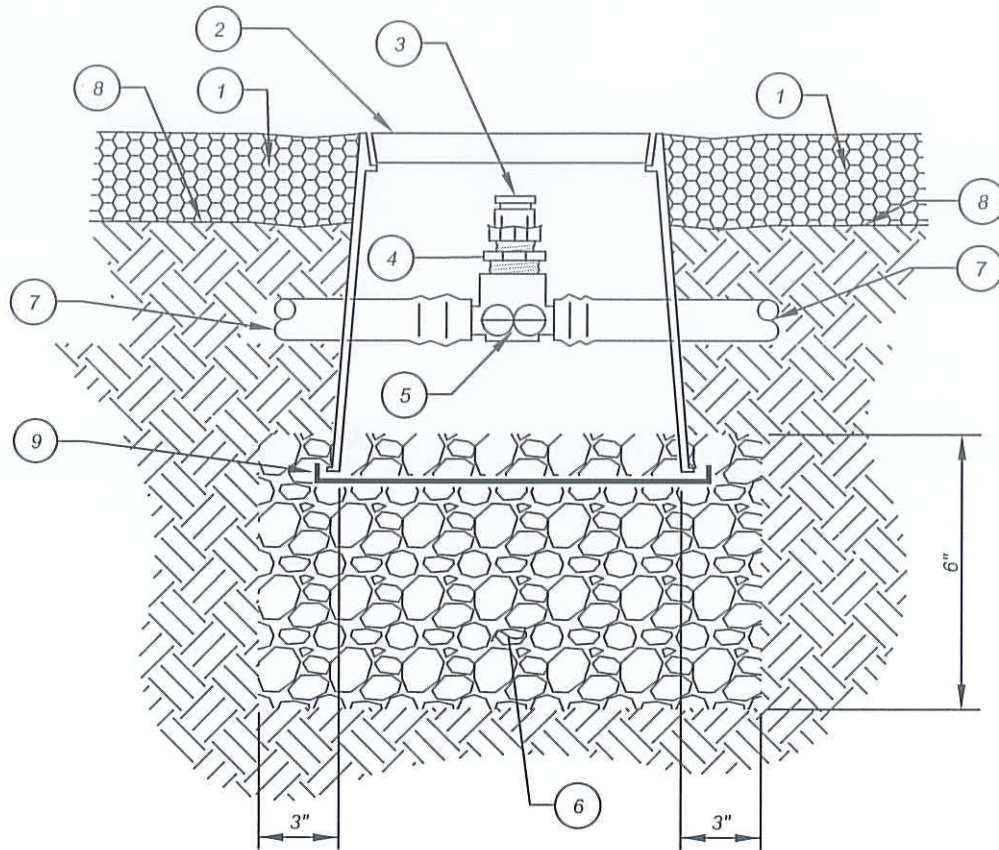



- 1 FINISH SURFACE OF MULCH (3" THICK)
- 2 6" ROUND VALVE BOX. SEE NOTE BELOW
- 3 AIR / VACUUM RELIEF VALVE
- 4 3/4" M x 1/2" F REDUCTION BUSHING
- 5 DRIPPERLINE COMBINATION TEE (1/2" x 1/2" x 3/4" FPT)
- 6 3/4" GRAVEL SUMP
- 7 DRIPPERLINE TUBING: FROM SURFACE INTO BOX TYPICAL
- 8 SOIL SURFACE FINISH GRADE, 3"-4" COVER OVER PIPE
- 9 1/4" GALVANIZED WIRE MESH

**NOTE:**

TOP OF VALVE BOX TO BE INSTALLED 3" ABOVE FINISH GRADE IN PLANTER AREAS, AND EVEN WITH FINISH SURFACE OF MULCH.

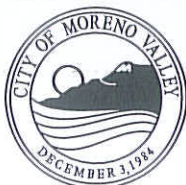
NOT TO SCALE



RECOMMENDED:  
  
 DIVISION MANAGER DATE  
 APPROVED:  
  
 PUBLIC WORKS DIRECTOR / DATE  
 CITY ENGINEER

**CITY OF MORENO VALLEY**  
 FINANCIAL & MANAGEMENT SERVICES DEPARTMENT - SPECIAL DISTRICTS DIVISION

**AIR / VACUUM RELIEF VALVE  
 (FOR DRIPPERLINE)**

STANDARD PLAN  
**MVLI-574K-0**

SHEET 11 OF 12



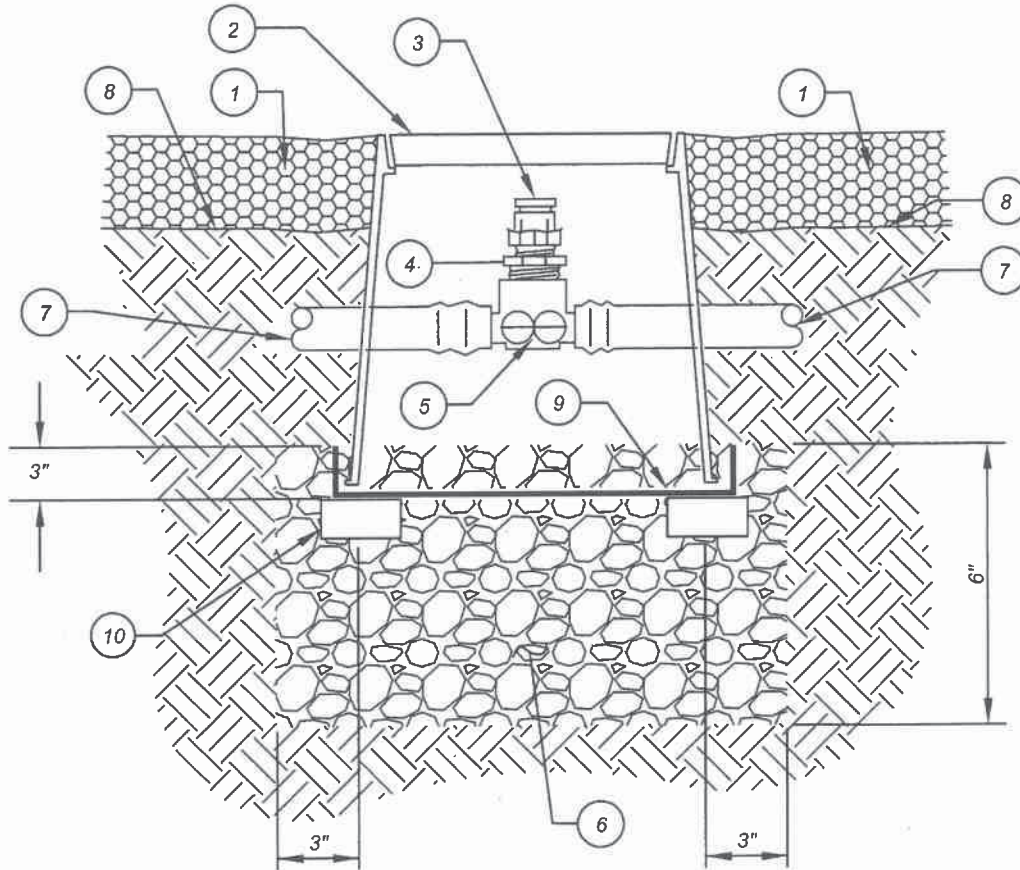

- 1 FINISH SURFACE OF MULCH (3" THICK)
- 2 6" ROUND VALVE BOX WITH BOLT AND WASHER. SEE NOTE BELOW
- 3 AIR / VACUUM RELIEF VALVE
- 4 3/4" M x 1/2" F REDUCTION BUSHING
- 5 DRIPPERLINE COMBINATION TEE (INS x INS x 3/4" FPT)
- 6 3/4" GRAVEL SUMP
- 7 DRIPPERLINE TUBING: FROM SURFACE INTO BOX TYPICAL
- 8 SOIL SURFACE FINISH GRADE, 3"-4" COVER OVER PIPE
- 9 1/4" STAINLESS STEEL WIRE MESH, TYPE 316
- 10 CONCRETE PAVER SUPPORT (3 PER BOX)

**NOTE:**

TOP OF VALVE BOX TO BE INSTALLED 3" ABOVE FINISH GRADE IN PLANTER AREAS, AND EVEN WITH FINISH SURFACE OF MULCH.

NOT TO SCALE



RECOMMENDED:

DIVISION MANAGER

DATE

APPROVED:

PUBLIC WORKS DIRECTOR /  
CITY ENGINEER

DATE

# CITY OF MORENO VALLEY

PARKS AND COMMUNITY SERVICES DEPARTMENT

## AIR / VACUUM RELIEF VALVE (FOR DRIPPERLINE)

STANDARD PLAN

**MVLI-574L-1**

SHEET 12 OF 12

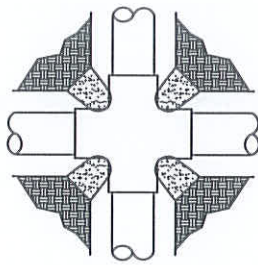

**CROSS**

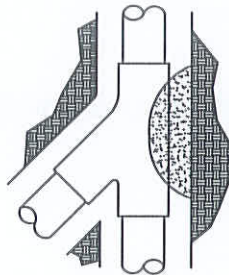

**WYE**



**45 DEGREE ELBOW**

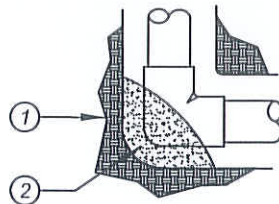

**90 DEGREE TURN**

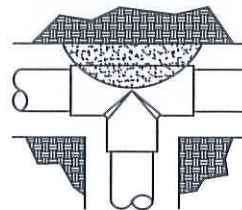

**TEE**

**PLAN VIEW**

**LEGEND:**

- ① SUBGRADE (TYPICAL)
- ② TYPICAL CONCRETE PLACEMENT

**NOTES:**

- 1) THRUST BLOCKS SHALL BE CLASS 560-C-3250 UNLESS OTHERWISE SPECIFIED.
- 2) SIZE AND TYPE OF THRUST BLOCKS SHALL BE SPECIFIED ON PLANS.

NOT TO SCALE

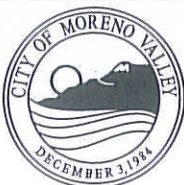

RECOMMENDED:  
 1/16/14  
 DIVISION MANAGER DATE

APPROVED:  
 1/29/14  
 PUBLIC WORKS DIRECTOR / DATE  
 CITY ENGINEER

**CITY OF MORENO VALLEY**  
 FINANCIAL & MANAGEMENT SERVICES DEPARTMENT - SPECIAL DISTRICTS DIVISION

**THRUST BLOCKS**

STANDARD PLAN  
**MVLI-580A-0**

SHEET 1 OF 2

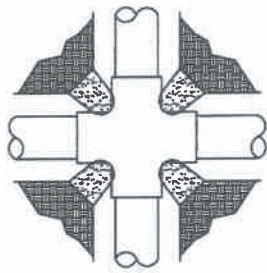

**CROSS**

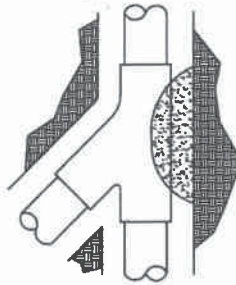

**WYE**



**45 DEGREE ELBOW**

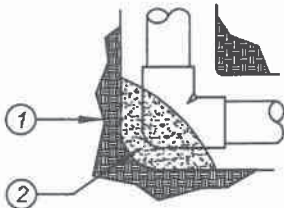

**90 DEGREE TURN**

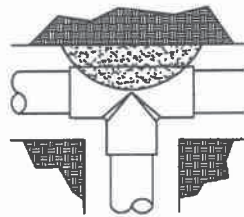

**TEE**

**PLAN VIEW**



**LEGEND:**

- ① SUBGRADE (TYPICAL)
- ② TYPICAL CONCRETE PLACEMENT

**NOTES:**

- 1.) THRUST BLOCKS SHALL BE 3000 PSI UNLESS OTHERWISE SPECIFIED
- 2.) SIZE AND TYPE OF THRUST BLOCKS SHALL BE SPECIFIED ON PLANS
- 3.) REQUIRED ON ALL MAINLINE, INCLUDING DUCTILE IRON FITTINGS

NOT TO SCALE

	RECOMMENDED:  DIVISION MANAGER	<b>CITY OF MORENO VALLEY</b> PARKS AND COMMUNITY SERVICES DEPARTMENT	STANDARD PLAN
	APPROVED:  7/30/09 PUBLIC WORKS DIRECTOR / DATE CITY ENGINEER		DATE: 7/30/09
			SHEET 2 OF 2



**LEGEND:**

- ① JUMBO OR LARGER RECTANGULAR VALVE BOX PER SPECS
- ② STANDARD RECTANGULAR VALVE BOX PER SPECS
- ③ 10" DIA ROUND VALVE BOX
- ④ EDGE OF AREA, CURB, WALK OR WALL

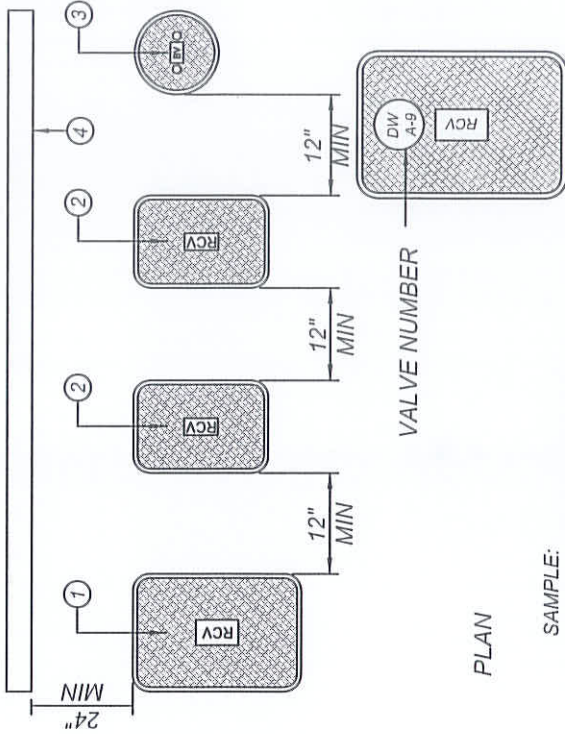

SAMPLE:  
 POTABLE WATER SYSTEM OF  
 CONTROLLER "A" REMOTE CONTROL  
 VALVE ON STA No 9

**NOTES:**

- A- VALVE BOXES SHALL BE LABELED BY HOT IRON BRANDING, 2" LETTERS/NUMBERS
- B- CONTROL VALVES SHALL BE INSTALLED TO ALLOW ORDERLY ARRANGEMENT OF VALVE BOXES.
- C- WHERE POSSIBLE LOCATE VALVE ASSEMBLIES IN SHRUB OR GROUND COVER AREAS ONLY 12" FROM HARDSCAPE.
- D- LOCATION OF VALVE ASSEMBLIES SHALL BE STAKED FOR APPROVAL BY LANDSCAPE ARCHITECT PRIOR TO INSTALLATION.
- E- CENTER VALVE BOXES OVER VALVE ASSEMBLY TO FACILITATE ACCESS AND MAINTENANCE.
- F- SET VALVE BOXES AT EQUAL ELEVATIONS W/ TOPS AT 3" ABOVE FINISH GRADE IN SHRUB/ GROUND COVER AREAS.
- G- VALVE BOXES SHALL BE SET PARALLEL TO EACH OTHER AND PERPENDICULAR TO EDGE OF AREA.
- H- DO NOT DEFORM OR COLLAPSE VALVE BOX BY EXCESSIVE SOIL COMPACTION AROUND BOX.
- I- SEE ALSO INDIVIDUAL VALVE INSTALLATION DETAILS.

IDENTIFICATION GUIDE		EQUIPMENT DESIGNATION	CONTROLLER LEGEND	RECLAIMED WATER	DOMESTIC WATER
AIR RELIEF VALVE	ARV	A	RW	DW	
BASKET STRAINERS	BS	A	RW	DW	
BALL VALVE	BV	A	RW	DW	
COMMUNICATION SPLICES	CCC	A	RW	DW	
DRINKING FOUNTAIN	DF	A	RW	DW	
FLOW SENSORS	FS	A	RW	DW	
FLUSH VALVE ASSEMBLY	FVA	A	RW	DW	
GROUNDING RODS	GR	A	RW	DW	
GATE VALVES	GV	A	RW	DW	
XXXX	HB	A	RW	DW	
MOISTURE SENSORS	MS	A	RW	DW	
MASTER VALVE	MV	A	RW	DW	
PULL BOX	PB	A	RW	DW	
REMOTE CONTROL VALVES	(STA NO.)	A	RW	DW	
QUICK COUPLERS	QC	A	RW	DW	

CONTACT PARKS AND COMMUNITY SERVICES FOR INFO ON ANY DEVICE IN A BOX NOT LISTED.

NOT TO SCALE



RECOMMENDED:  
*[Signature]* 1/29/14  
 DIVISION MANAGER DATE

APPROVED:  
*[Signature]* 1/29/14  
 PUBLIC WORKS DIRECTOR / DATE  
 CITY ENGINEER

**CITY OF MORENO VALLEY**  
 PARKS AND COMMUNITY SERVICES DEPARTMENT

**BOX IDENTIFICATION**

STANDARD PLAN  
**MVLI-581-0**  
 SHEET 1 OF 1



	<p>"CHRISTY" NO. 3150 MAXI-I.D. TAG IN BOTH ENGLISH AND SPANISH. USE IN ALL VALVE BOXES. USE PURPLE TAGS FOR RECLAIMED WATER OR FERTILIZER INSTECTOR SYSTEMS.</p>
<p>WARNING TAPE</p>	<p>"CHRISTY" 3" ND PRW NON-DETECTABLE PURPLE TAPE LABELED "CAUTION - RECLAIMED WATER BELOW" LOCATE ABOVE ALL MAINLINE</p>
<p>WARNING LABEL</p>	<p>"CHRISTY" NO. 4100 CONTROLLER UNIT LABEL - 3.5 MIL VINYL BASE (PURPLE) - ATTACH TO FACE OF CONTROLLER ENCL.</p>
<p>RISER LABEL</p>	<p>"CHRISTY" NO. 5100 RISER MARKER - 3.5 MIL VINYL BASE (PURPLE) - ATTACH TO IRRIGATION RISERS</p>

**NOTES:**

- 1.) THE CONTRACTOR MY OFFER ANY MATERIAL CONSIDERED TO BE EQUIVALENT TO THAT INDICATED.  
THE SUBSTITUTION OF MATERIAL SHALL BE SUBMITTED IN WRITING AND APPROVED IN WRITING  
BY THE CITY'S PROJECT MANAGER.

NOT TO SCALE

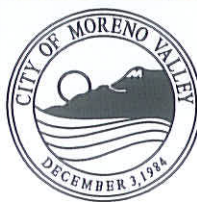
	<p>RECOMMENDED: <i>[Signature]</i> 1/27/14 DIVISION MANAGER      DATE</p>	<p align="center"><b>CITY OF MORENO VALLEY</b> PARKS AND COMMUNITY SERVICES DEPARTMENT</p>	
	<p>APPROVED: <i>[Signature]</i> 1/29/14 PUBLIC WORKS DIRECTOR/      DATE CITY ENGINEER</p>		

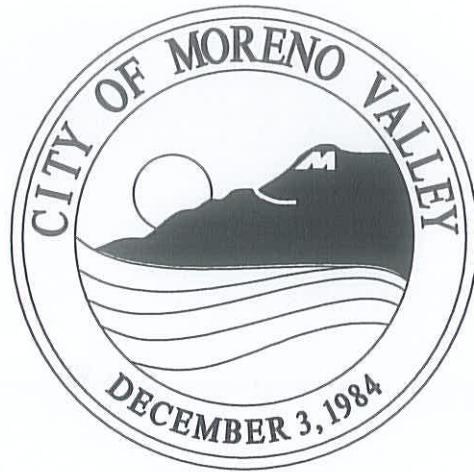

# **CITY OF MORENO VALLEY STANDARD PLANS**

## **SECTION 6**

### **GENERAL FACILITIES**

# City of Moreno Valley

## Standard Plans Index - 2022 Edition

---

### **SECTION 6:      General Facilities**

#### Parks Facilities

MVGF-600-0	<i>Parks and Community Services - General Notes</i>
MVGF-610A-1	<i>Multi-Use Trail</i>
MVGF-610B-0	<i>Multi-Use Trail</i>
MVGF-610C-0	<i>Multi-Use Trail</i>
MVGF-610D-0	<i>Multi-Use Trail</i>
MVGF-610E-0	<i>Multi-Use Feeder Trail</i>
MVGF-610F-0	<i>Multi-Use Trail</i>
MVGF-610G-0	<i>Multi-Use Trail</i>
MVGF-610H-0	<i>Multi-Use Trail</i>
MVGF-610I-1	<i>Multi-Use Trail</i>
MVGF-610J-0	<i>Multi-Use Trail</i>
MVGF-610K-0	<i>Multi-Use Trail</i>
MVGF-610L-0	<i>Riding and Hiking Trails</i>
MVGF-610M-0	<i>Multi-Use Trail Specifications</i>
MVGF-610N-1	<i>Multi-Use Trail Specifications</i>
MVGF-611-0	<i>Concrete Walk / Slab / Approach Adjacent To Trail</i>
MVGF-612-0	<i>Secondary Riding and Hiking</i>
MVGF-613A-0	<i>Trailhead Ingress / Egress Gate Detail</i>
MVGF-613B-0	<i>Single Trail Access Gate</i>
MVGF-613C-0	<i>Double Trail Access Gate</i>
MVGF-613D-0	<i>Double Trail Access Gate with Center Opening</i>
MVGF-613E-0	<i>EZ 55 Bracket with Post</i>
MVGF-614A-0	<i>24" x 24" Catch Basin</i>
MVGF-614B-0	<i>Typical Area Drain</i>
MVGF-615A-0	<i>Drinking Fountain Sump Drainage Detail</i>
MVGF-615B-0	<i>Drinking Fountain and Bottle Filler</i>
MVGF-616-0	<i>Cable Railing</i>
MVGF-617-0	<i>Hitching Rail</i>
MVGF-618A-0	<i>Electrical Pull Box for Parks</i>
MVGF-618B-0	<i>Trench Details for Conduit Installations in Parks</i>
MVGF-619-0	<i>Retaining Walls for Pad-Mounted Meter Enclosures</i>
MVGF-620A-0	<i>Graphic Plan, Two Sided Sign (96" L x 60" HT)</i>
MVGF-620B-0	<i>Construction Plan, Two Sided Sign (90" L x 60" HT)</i>
MVGF-620C-0	<i>Construction Plan, Sign Base (12" W x 102" L)</i>
MVGF-620D-0	<i>Installation Plan, Two Sided Sign (96" L x 60" HT)</i>
MVGF-621A-0	<i>Graphic Plan, One Sided Sign (96" L x 60" HT)</i>
MVGF-621B-0	<i>Construction Plan, One Sided Sign (96" L x 60" HT)</i>
MVGF-621C-0	<i>Construction Plan, Sign Base (12" W x 102" L)</i>
MVGF-621D-0	<i>Installation Plan, One Sided Sign (96" L x 60" HT)</i>
MVGF-622-0	<i>Horse Watering Station</i>
MVGF-623A-1	<i>Parking Lots</i>
MVGF-623B-0	<i>Join Existing Parking Lot Pavement Detail</i>

# City of Moreno Valley

## Standard Plans Index - 2022 Edition

---

### **SECTION 6:      General Facilities**

#### Parks Facilities

MVGF-600-0	<i>Parks and Community Services - General Notes</i>
MVGF-610A-1	<i>Multi-Use Trail</i>
MVGF-610B-0	<i>Multi-Use Trail</i>
MVGF-610C-0	<i>Multi-Use Trail</i>
MVGF-610D-0	<i>Multi-Use Trail</i>
MVGF-610E-0	<i>Multi-Use Feeder Trail</i>
MVGF-610F-0	<i>Multi-Use Trail</i>
MVGF-610G-0	<i>Multi-Use Trail</i>
MVGF-610H-0	<i>Multi-Use Trail</i>
MVGF-610I-1	<i>Multi-Use Trail</i>
MVGF-610J-0	<i>Multi-Use Trail</i>
MVGF-610K-0	<i>Multi-Use Trail</i>
MVGF-610L-0	<i>Riding and Hiking Trails</i>
MVGF-610M-0	<i>Multi-Use Trail Specifications</i>
MVGF-610N-1	<i>Multi-Use Trail Specifications</i>
MVGF-611-0	<i>Concrete Walk / Slab / Approach Adjacent To Trail</i>
MVGF-612-0	<i>Secondary Riding and Hiking</i>
MVGF-613A-0	<i>Trailhead Ingress / Egress Gate Detail</i>
MVGF-613B-0	<i>Single Trail Access Gate</i>
MVGF-613C-0	<i>Double Trail Access Gate</i>
MVGF-613D-0	<i>Double Trail Access Gate with Center Opening</i>
MVGF-613E-0	<i>EZ 55 Bracket with Post</i>
MVGF-614A-0	<i>24" x 24" Catch Basin</i>
MVGF-614B-0	<i>Typical Area Drain</i>
MVGF-615A-0	<i>Drinking Fountain Sump Drainage Detail</i>
MVGF-615B-0	<i>Drinking Fountain and Bottle Filler</i>
MVGF-616-0	<i>Cable Railing</i>
MVGF-617-0	<i>Hitching Rail</i>
MVGF-618A-0	<i>Electrical Pull Box for Parks</i>
MVGF-618B-0	<i>Trench Details for Conduit Installations in Parks</i>
MVGF-619-0	<i>Retaining Walls for Pad-Mounted Meter Enclosures</i>
MVGF-620A-0	<i>Graphic Plan, Two Sided Sign (96" L x 60" HT)</i>
MVGF-620B-0	<i>Construction Plan, Two Sided Sign (90" L x 60" HT)</i>
MVGF-620C-0	<i>Construction Plan, Sign Base (12" W x 102" L)</i>
MVGF-620D-0	<i>Installation Plan, Two Sided Sign (96" L x 60" HT)</i>
MVGF-621A-0	<i>Graphic Plan, One Sided Sign (96" L x 60" HT)</i>
MVGF-621B-0	<i>Construction Plan, One Sided Sign (96" L x 60" HT)</i>
MVGF-621C-0	<i>Construction Plan, Sign Base (12" W x 102" L)</i>
MVGF-621D-0	<i>Installation Plan, One Sided Sign (96" L x 60" HT)</i>
MVGF-622-0	<i>Horse Watering Station</i>
MVGF-623A-1	<i>Parking Lots</i>
MVGF-623B-0	<i>Join Existing Parking Lot Pavement Detail</i>



# City of Moreno Valley

## Standard Plans Index - 2022 Edition

---

### **SECTION 6:      General Facilities (Continued)**

<i>MVGF-623C-1</i>	<i>Concrete Pavement Joint</i>
<i>MVGF-623D-0</i>	<i>Parks Striping and Pavement Legend Standards &amp; Specifications</i>
<i>MVGF-623E-0</i>	<i>Type 6 Integral Curb and Gutter for Parks</i>
<i>MVGF-623F-0</i>	<i>Type 8A Curb for Parks</i>
<i>MVGF-623G-0</i>	<i>Type C Rolled Curb for Parks</i>
<i>MVGF-623H-0</i>	<i>Curb Separated Walkway for Parks</i>
<i>MVGF-623I-0</i>	<i>Walk Way Placement around Obstructions for Parks</i>
<i>MVGF-623J-0</i>	<i>Tree Well for Parks</i>
<i>MVGF-623K-0</i>	<i>Commercial Driveway Approach for Parks</i>
<i>MVGF-624A-0</i>	<i>Parks Facility Dedication Plaque</i>
<i>MVGF-624B-0</i>	<i>Parks Dedication Plaque Pedestal</i>
<i>MVGF-625A-0</i>	<i>Sign Post Installation in Parks</i>
<i>NVGF-625B-0</i>	<i>Parks Sign Post Installation Notes</i>
<i>MVGF-626-0</i>	<i>Concrete Light Pole Base</i>
<i>MVGF-627A-0</i>	<i>Pole Base Fixture Footing For Parks</i>
<i>MVGF-627B-0</i>	<i>Light Pole With Above Grade Pole Base</i>

#### Fences and Gates

<i>MVGF-640-0</i>	<i>3-Rail PVC Fence</i>
<i>MVGF-641-0</i>	<i>Park Projects Chain Link Fence and Gates</i>
<i>MVGF-642-0</i>	<i>Fire Access Gate</i>
<i>MVGF-643A-0</i>	<i>Steel Fence &amp; Gate</i>
<i>MVGF-643B-0</i>	<i>Steel Fence &amp; Gate for Cell Sites</i>
<i>MVGF-644-0</i>	<i>Modified Extended Detention Basin Fence &amp; Gate Detail Guide</i>

#### Retaining Wall

<i>MVGF-650A-0</i>	<i>Retaining Wall Notes for Electrical Facilities</i>
<i>MVGF-650B-0</i>	<i>Retaining Wall Sections for Electrical Facilities</i>



#### Waste Enclosure

<i>MVGF-660A-1</i>	<i>Dual Bin Covered Waste Enclosure For Parks Case A</i>
<i>MVGF-660B-1</i>	<i>Dual Bin Covered Waste Enclosure For Parks Case B</i>
<i>MVGF-660C-1</i>	<i>Dual Bin Covered Waste Enclosure For Parks Notes</i>
<i>MVGF-660D-1</i>	<i>Waste Enclosure Gate for Parks</i>
<i>MVGF-660E-1</i>	<i>Waste Enclosure Wall and Footing for Parks</i>
<i>MVGF-660F-1</i>	<i>Waste Enclosure Gate Hinge for Parks</i>

**DEPARTMENT OF PARKS AND COMMUNITY SERVICES GENERAL NOTES:**

- A. ALL WORK SHALL BE DONE IN ACCORDANCE WITH THE MOST RECENT VERSIONS (AT TIME OF CONSTRUCTION) OF : THE CITY OF MORENO VALLEY PARK AND COMMUNITY SERVICES LANDSCAPE DEVELOPMENT GUIDELINES, SPECIFICATIONS, DRAWINGS, GREENBOOK SPECIFICATIONS FOR PUBLIC WORKS PROJECTS, AND THE CALIFORNIA BUILDING CODE.
- B. TURF AREAS SHALL HAVE A MAXIMUM DESIGN SLOPE OF 20% AND A MINIMUM DESIGN OF 1%.
- C. ALL CONCRETE SHALL ADHERE TO THE "GREENBOOK" FOR ITS SPECIFIC TYPE OF APPLICATION. MINIMUM REQUIREMENTS ARE 2500 PSI WITH NO SUBSTITUTES FOR PORTLAND CEMENT. COLOR AND FINISH SAMPLES SHALL BE PROVIDED TO THE PARKS AND COMMUNITY SERVICES PROJECT MANAGER FOR APPROVAL PRIOR TO INSTALLATION. PUMP MIXES SHALL BE 3250 PSI.
- D. CONTRACTOR / DEVELOPER SHALL PROVIDE A 12", #4 REINFORCED CONCRETE MOW STRIP BETWEEN TURF AND GROUND COVER AND A 12" CONCRETE MOW STRIP BETWEEN TURF AND WALLS, UNLESS SPECIFICALLY AUTHORIZED OTHERWISE BY PARKS AND COMMUNITY SERVICES.
- E. THE CONTRACTOR IS RESPONSIBLE FOR OBTAINING GRADING AND BUILDING PERMITS PRIOR TO COMMENCING CONSTRUCTION. PARKS AND COMMUNITY SERVICES WILL OBTAIN BUILDING PERMITS FOR CITY FUNDED PROJECTS.
- F. THE CONTRACTOR MUST NOTIFY THE PARKS AND COMMUNITY SERVICES PROJECT MANAGER AND THE BUILDING AND SAFETY DIVISION A MINIMUM OF TWO (2) WORKING DAYS (MONDAY - FRIDAY, EXCLUDING HOLIDAYS) PRIOR TO COMMENCING CONSTRUCTION AND / OR INSPECTION.
- G. ALL CONSTRUCTION WORK SHALL BE PERFORMED MONDAY THROUGH FRIDAY (EXCLUDING HOLIDAYS), BETWEEN THE HOURS OF 7 AM AND 4 PM. ANY EXCEPTIONS TO THIS SCHEDULE MUST BE APPROVED IN WRITING FROM PARKS AND COMMUNITY SERVICES.
- H. LANDSCAPE OR IRRIGATION CONTRACTOR SHALL VERIFY EXISTING WATER PRESSURE AT THE JOB SITE PRIOR TO INSTALLING LANDSCAPE IRRIGATION SYSTEM. A GAUGE THAT RECORDS MAINLINE PRESSURE AND FLOW IS REQUIRED FOR 24 HOUR / 7 DAY PERIOD.
- I. A MAINLINE TEST (IRRIGATION AND PORTABLE WATER) AT 150 PSI FOR 4 HOURS SHALL BE SCHEDULED WITH PARKS AND COMMUNITY SERVICES. IF WATER PRESSURE IS LESS THAN DESIGNED PRESSURE, THE CONTRACTOR WILL CONTACT THE ARCHITECT REGARDING THE FINDINGS AND WILL CEASE IRRIGATION WORK UNTIL A SOLUTION IS PROVIDED AND APPROVED IN WRITING BY THE PARKS AND COMMUNITY SERVICES PROJECT MANAGER. MAINLINE TESTS MUST HAVE ALL APPURTENANCES ATTACHED (VALVES, UNIONS, ETC.)
- J. THE CONTRACTOR IS RESPONSIBLE FOR INSTALLING AN IRRIGATION SYSTEM THAT PROVIDES COMPLETE COVERAGE TO PLANT MATERIAL IN A MATURE STAGE. IRRIGATION MODIFICATIONS MAY BE REQUIRED TO KEEP WATER OFF OF LIGHT FIXTURES, DRINKING FOUNTAINS, PLAY EQUIPMENT, PICNIC AREAS, STRUCTURES, FENCING, SIDEWALKS, ETC.
- K. AT THE CONCLUSION OF ROUGH GRADING, AGRONOMIC SOILS TESTING SHALL BE PROVIDED FOR THE PUBLIC LANDSCAPED AREA AND AREAS THAT ARE ADJACENT TO PUBLIC RIGHT-OF-WAY AND THE RESULTS APPROVED BY PARKS AND COMMUNITY SERVICES, PRIOR TO ANY LANDSCAPE INSTALLATION.
- L. A COMPREHENSIVE SOILS TEST IS REQUIRED PRIOR TO PLACING ANY CONCRETE (PCC OR AC) AND BACK FILLED TRENCHES. THIS WILL BE USED TO DETERMINE THE CONCRETE DESIGN AND NECESSITY OF ADDITIONAL BASE MATERIALS ABOVE THE DESIGN ON THE PLANS AND CITY STANDARDS. THE PLAN DESIGN AND CITY STANDARDS SHALL SET THE MINIMUM STANDARDS.
- M. ALL LOAD TICKETS OR RECEIPTS SHALL BE PROVIDED TO PARKS AND COMMUNITY SERVICES WITHIN 24 HOURS OF RECEIPT OF PRODUCT. COPIES OF LOAD TICKETS / RECEIPTS INCLUDE BUT ARE NOT LIMITED TO CONCRETE; SOIL AND LANDSCAPE PRODUCTS; PLANT MATERIAL; FENCING AND BUILDING MATERIALS.
- N. ALL 'SUBMITTALS' AND SHOP DRAWINGS SHALL BE PROVIDED TO PARKS AND COMMUNITY SERVICES WITHIN THE FIRST 30-DAYS OF THE AWARD OF CONTRACT.
- O. ALL MATERIALS SHALL BE AS SPECIFIED WITHIN THE PLANS AND SPECIFICATIONS. 'EQUALS OR SUBSTITUTIONS' WILL ONLY BE CONSIDERED WITHIN THE FIRST 30-DAYS AFTER THE AWARD OF CONTRACT. THE PARKS AND COMMUNITY SERVICES PROJECT MANAGER SHALL APPROVE IN WRITING ALL 'EQUALS OR SUBSTITUTIONS'. THE CONTRACTOR SHALL REPLACE AT THE CONTRACTOR'S COST ANY PRODUCT UTILIZED THAT HAS NOT BEEN APPROVED IN WRITING BY THE PARKS AND COMMUNITY SERVICES PROJECT MANAGER.
- P. THE CONTRACTOR SHALL COORDINATE WITH AND NOTIFY THE PARKS AND COMMUNITY SERVICES PROJECT MANAGER OF THE REQUIRED PRE-CONSTRUCTION MEETING TO BE HELD ON SITE.
- Q. THE CONTRACTOR OR DEVELOPER SHALL GUARANTEE ALL MATERIALS AND WORKMANSHIP FOR A PERIOD OF ONE (1) YEAR AFTER PARKS AND COMMUNITY SERVICES ACCEPTS THE SITE IMPROVEMENTS.
- R. THE CONTRACTOR OR DEVELOPER SHALL MAINTAIN ALL LANDSCAPING FOR A PERIOD OF ONE (1) YEAR AFTER THE PARKS AND COMMUNITY SERVICES HAS ACCEPTED ALL IMPROVEMENTS FOR MAINTENANCE WITHIN COMMUNITY SERVICES DISTRICTS. BOND'S SHALL BE REQUIRED IN THE AMOUNT TO COVER THE WORK. CITY FUNDED PROJECTS ARE EXEMPT FROM THIS REQUIREMENT.

NOT TO SCALE

	RECOMMENDED:  9/20/19 DIVISION MANAGER DATE	<b>CITY OF MORENO VALLEY</b> PARKS AND COMMUNITY SERVICES DEPARTMENT	
	APPROVED:  10/16/19 PUBLIC WORKS DIRECTOR / DATE CITY ENGINEER	<b>PARKS AND COMMUNITY SERVICES                  GENERAL NOTES</b>	

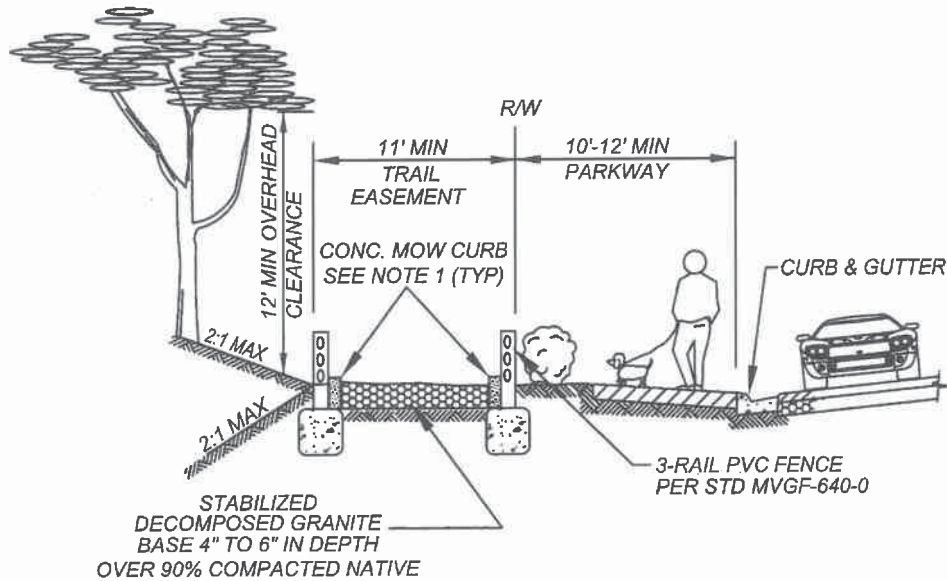

**MULTI-USE TRAIL  
ADJACENT TO STREET WITH SIDEWALK**

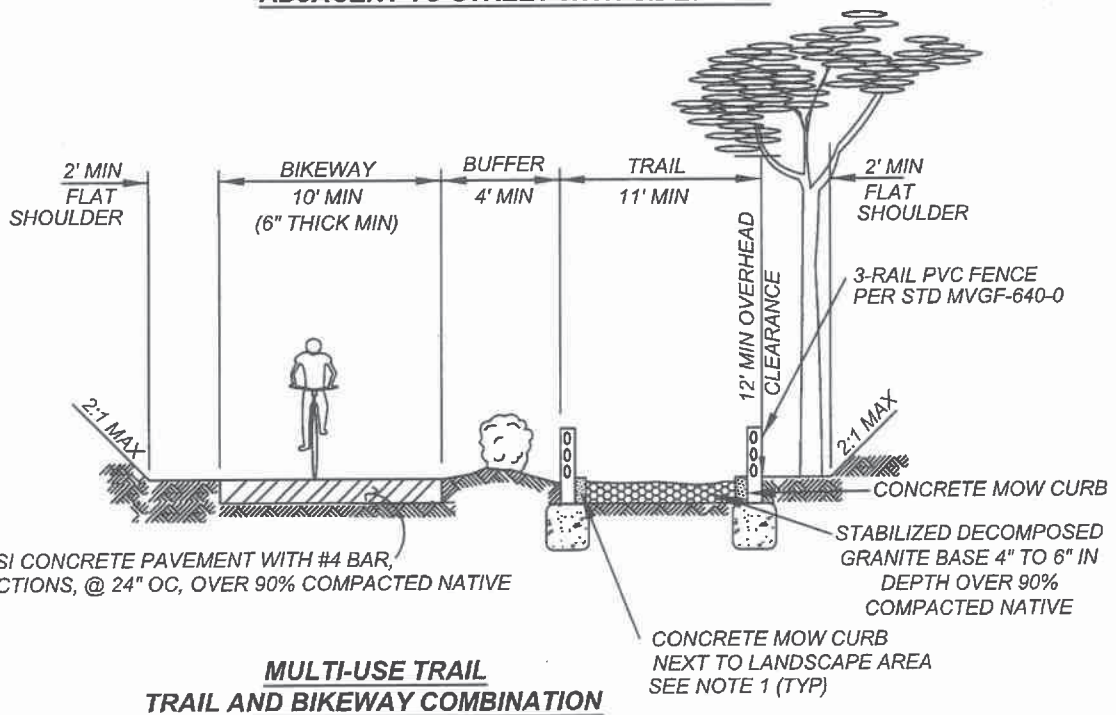

**NOTES:**

- 1.) CONCRETE MOW CURB REQUIRED NEXT TO LANDSCAPE AREAS (REFER TO STANDARD MVLI-522B-0 FOR MOW CURB DETAIL).
- 2.) CLASS I & II BIKE ROUTES TO BE STRIPED AND DESIGNATED WITH SIGNAGE.
- 3.) CLASS III BIKE ROUTES DESIGNATED WITH SIGNAGE ONLY.

NOT TO SCALE



RECOMMENDED:  
  
 DIVISION MANAGER      DATE 6/20/19  
 APPROVED:  
  
 PUBLIC WORKS DIRECTOR / DATE 7/30/19  
 CITY ENGINEER

**CITY OF MORENO VALLEY**  
 PARKS AND COMMUNITY SERVICES DEPARTMENT

**MULTI-USE TRAIL**

STANDARD PLAN  
**MVGF-610A-1**

SHEET 1 OF 14

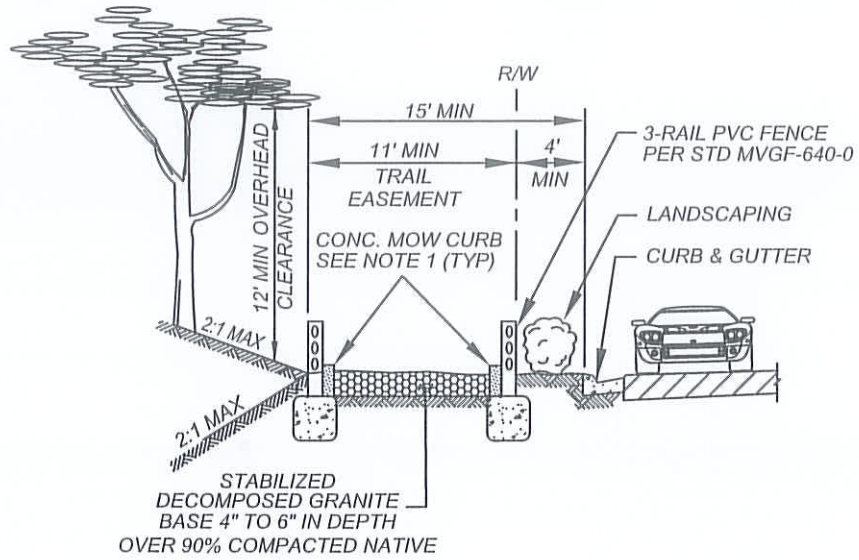

**MULTI-USE TRAIL**  
**ADJACENT TO STREET WITHOUT SIDEWALK**

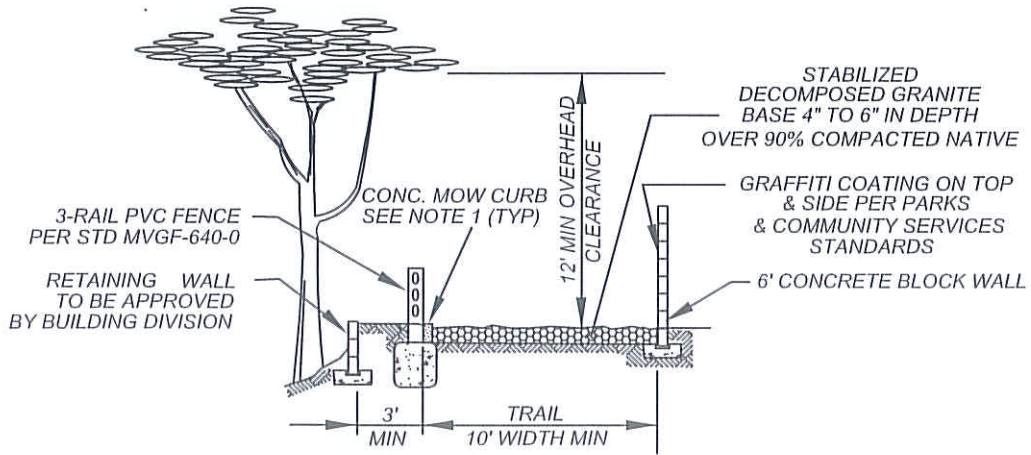

**SECONDARY MULTI-USE TRAIL**  
**ADJACENT TO FENCE, BLOCK WALL**  
**OR RETAINING WALL**

**NOTES:**

1.) CONCRETE MOW CURB REQUIRED NEXT TO LANDSCAPE AREAS (REFER TO STANDARD MVLI-522B-0 FOR MOW CURB DETAIL).

NOT TO SCALE



	RECOMMENDED:  DIVISION MANAGER      DATE	<b>CITY OF MORENO VALLEY</b> PARKS AND COMMUNITY SERVICES DEPARTMENT	STANDARD PLAN
	APPROVED:  PUBLIC WORKS DIRECTOR / DATE CITY ENGINEER		<b>MULTI-USE TRAIL</b>

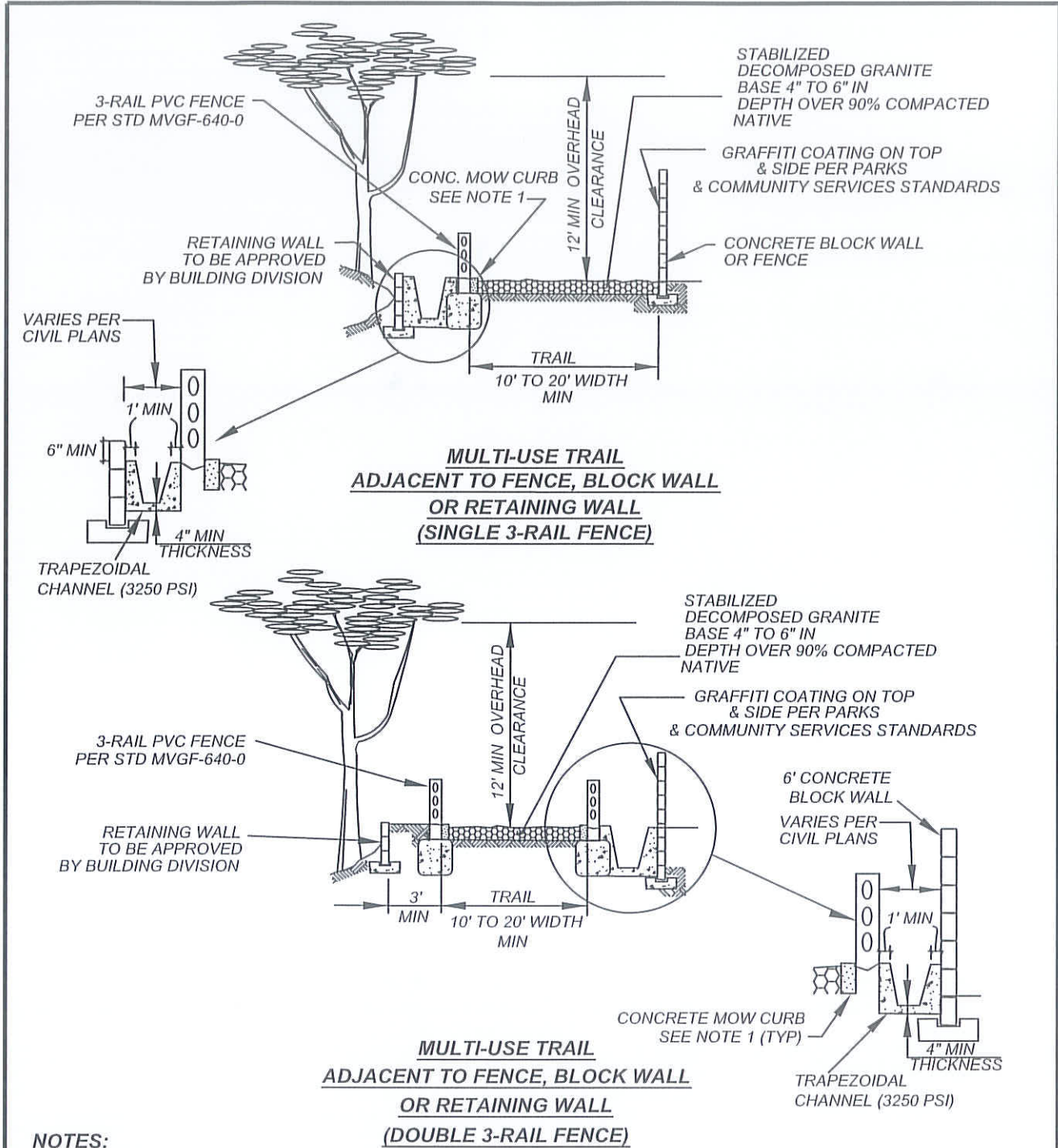



**NOTES:**

- 1.) CONCRETE MOW CURB REQUIRED NEXT TO LANDSCAPE AREAS (REFER TO STANDARD MVLI-522B-0 FOR MOW CURB DETAIL).
- 2.) TRAIL SHALL BE PROTECTED WITH 3 - RAIL PVC FENCE ADJACENT TO DRAINAGE TRAPEZOIDAL CHANNEL. NOT TO SCALE

	RECOMMENDED:  DIVISION MANAGER      DATE	<h2 style="margin: 0;">CITY OF MORENO VALLEY</h2> <p style="margin: 0;">PARKS AND COMMUNITY SERVICES DEPARTMENT</p>	STANDARD PLAN <b>MVGF-610C-0</b>
	APPROVED:  PUBLIC WORKS DIRECTOR / DATE CITY ENGINEER		<b>MULTI-USE TRAIL</b>

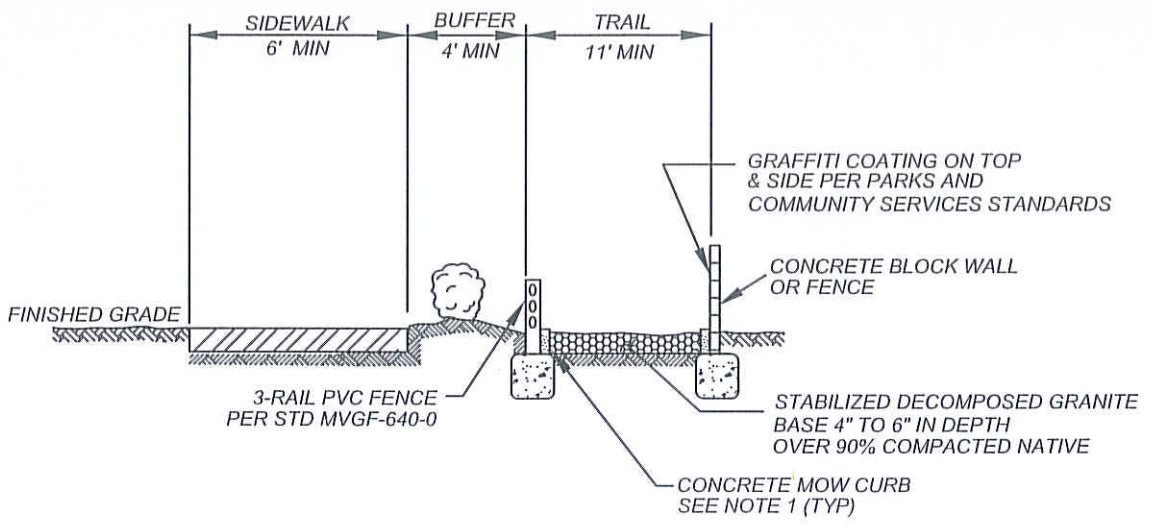

**TRAIL AND SIDEWALK COMBINATION**

**NOTES:**

1.) CONCRETE MOW CURB REQUIRED NEXT TO LANDSCAPE AREAS (REFER TO STANDARD MVLI-522B-0 FOR MOW CURB DETAIL).

NOT TO SCALE

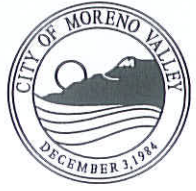
	RECOMMENDED: <i>FD</i> 1/21/14 DIVISION MANAGER DATE	<b>CITY OF MORENO VALLEY</b> PARKS AND COMMUNITY SERVICES DEPARTMENT	
	APPROVED: <i>MM</i> 1/29/14 PUBLIC WORKS DIRECTOR / DATE CITY ENGINEER		
			SHEET 4 OF 14

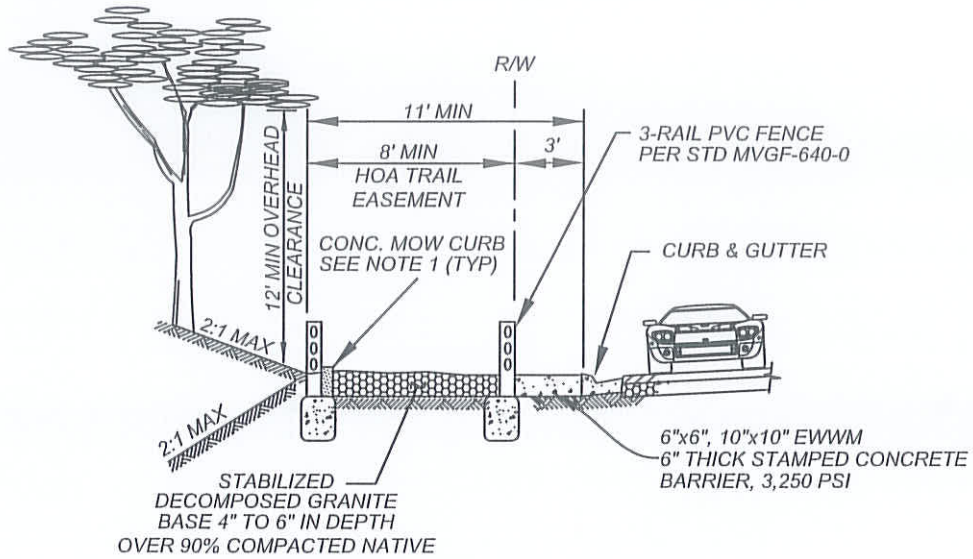

**HOA MULTI-USE FEEDER TRAIL**  
**ADJACENT TO STREET WITHOUT SIDEWALK**

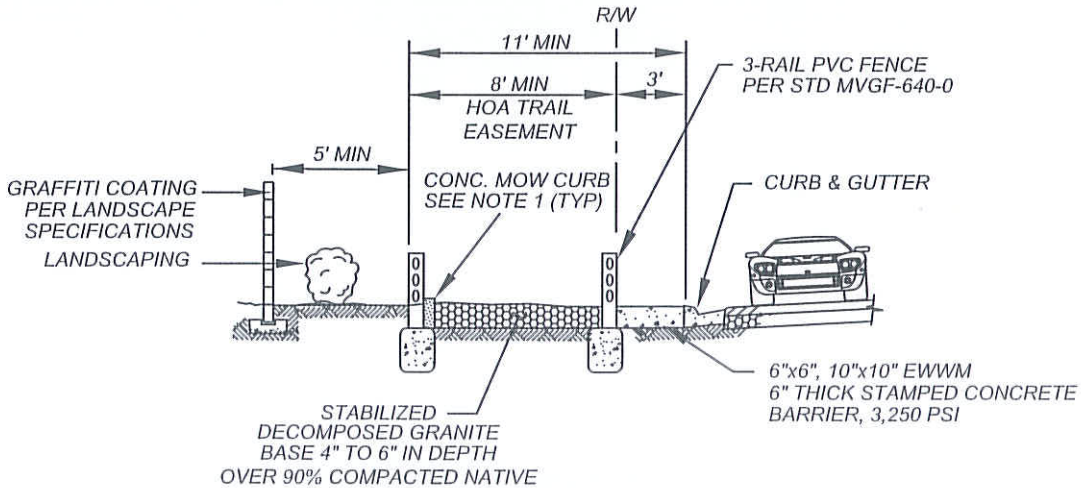

**HOA SIDEYARD**  
**MULTI-USE FEEDER TRAIL**  
**ADJACENT TO STREET WITHOUT SIDEWALK**

**NOTES:**

- 1.) CONCRETE MOW CURB REQUIRED NEXT TO LANDSCAPE AREAS (REFER TO STANDARD MVLI-522B-0 FOR MOW CURB DETAIL).
- 2.) THE 3' WIDE STAMPED CONCRETE BARRIER SHALL BE COBBLESTONE RUNNING BOND PATTERN BY L. M. SCOFIELD WITH OMAHA TAN COLORING BY DAVIS COLORING OR APPROVED EQUAL.
- 3.) THE 3' STAMPED CONCRETE AREA BEHIND CURB IS DESIGNED TO BE FOR UTILITY EASEMENTS.

NOT TO SCALE

	RECOMMENDED:  DIVISION MANAGER      DATE 1/21/14	<b>CITY OF MORENO VALLEY</b> PARKS AND COMMUNITY SERVICES DEPARTMENT	
	APPROVED:  PUBLIC WORKS DIRECTOR / DATE 1/29/14 CITY ENGINEER	<b>MULTI-USE FEEDER TRAIL</b>	
			SHEET 5 OF 14



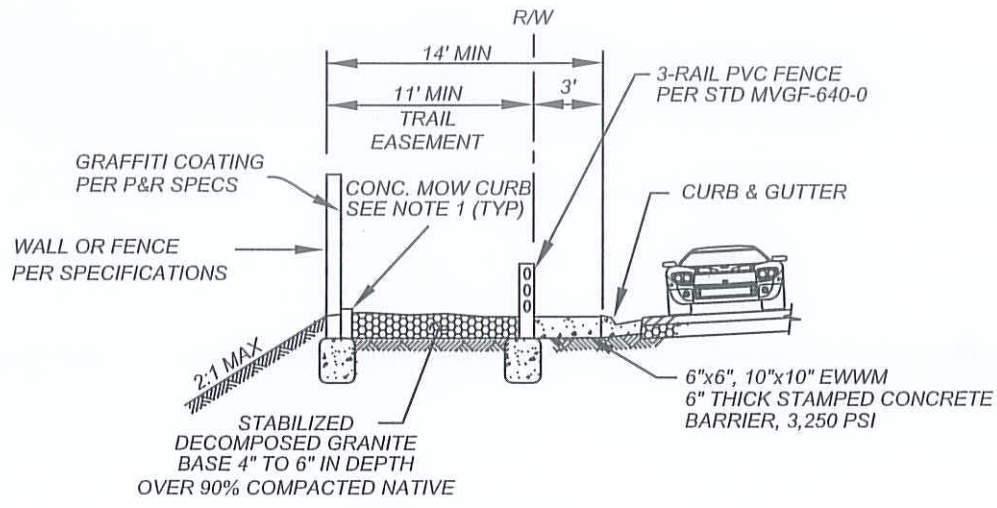

**MULTI-USE TRAIL  
ADJACENT TO STREET WITHOUT SIDEWALK**

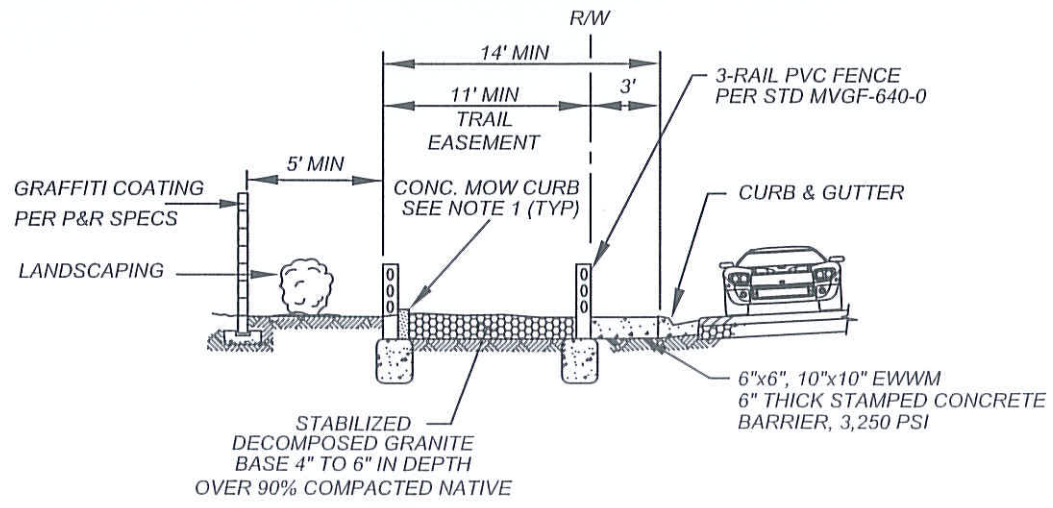

**MULTI-USE TRAIL & PLANTER  
ADJACENT TO STREET WITHOUT SIDEWALK**

**NOTES:**

- 1.) CONCRETE MOW CURB REQUIRED NEXT TO LANDSCAPE AREAS (REFER TO STANDARD MVLI-522B-0 FOR MOW CURB DETAIL).
- 2.) THE 3' WIDE STAMPED CONCRETE BARRIER SHALL BE COBBLESTONE RUNNING BOND PATTERN BY L. M. SCOFIELD WITH OMAHA TAN COLORING BY DAVIS COLORING OR APPROVED EQUALS.

NOT TO SCALE

	RECOMMENDED: <i>JLB</i> 1/21/14 DIVISION MANAGER      DATE	<h2 style="margin: 0;">CITY OF MORENO VALLEY</h2> <p style="margin: 0;">PARKS AND COMMUNITY SERVICES DEPARTMENT</p>	<p>STANDARD PLAN</p> <h3 style="margin: 0;">MVGF-610F-0</h3>
	APPROVED: <i>[Signature]</i> 1/29/14 PUBLIC WORKS DIRECTOR // DATE CITY ENGINEER		
			SHEET 6 OF 14



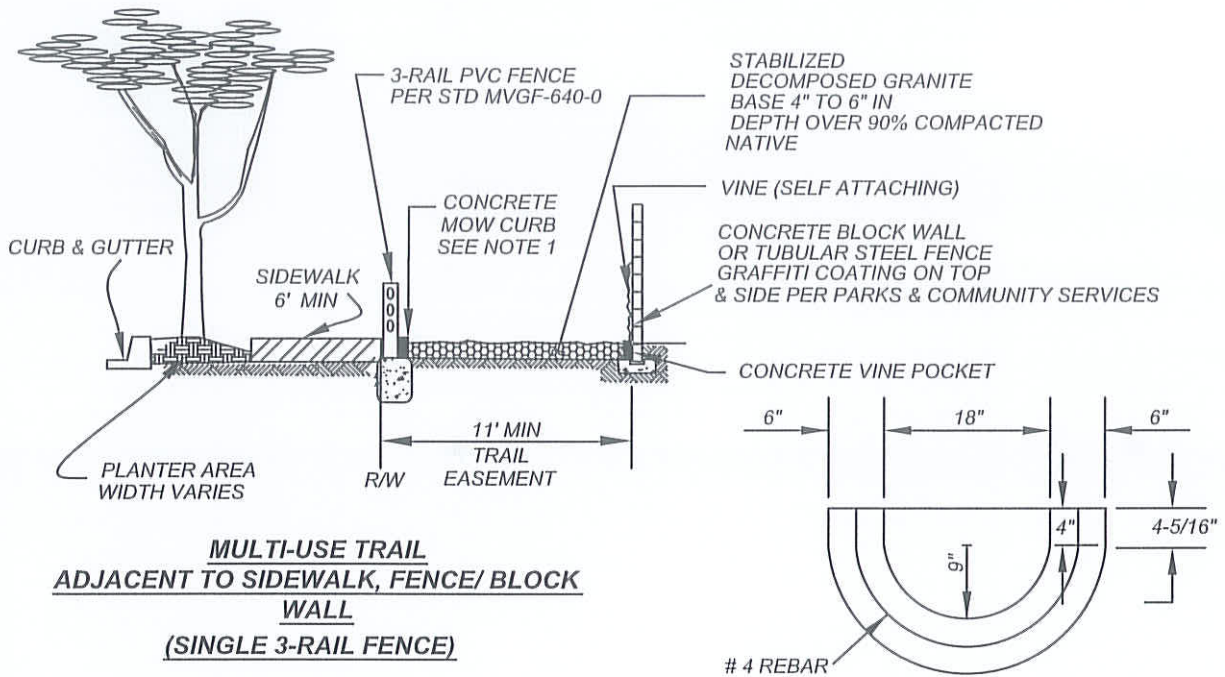

**6" THICK CONCRETE VINE POCKET**

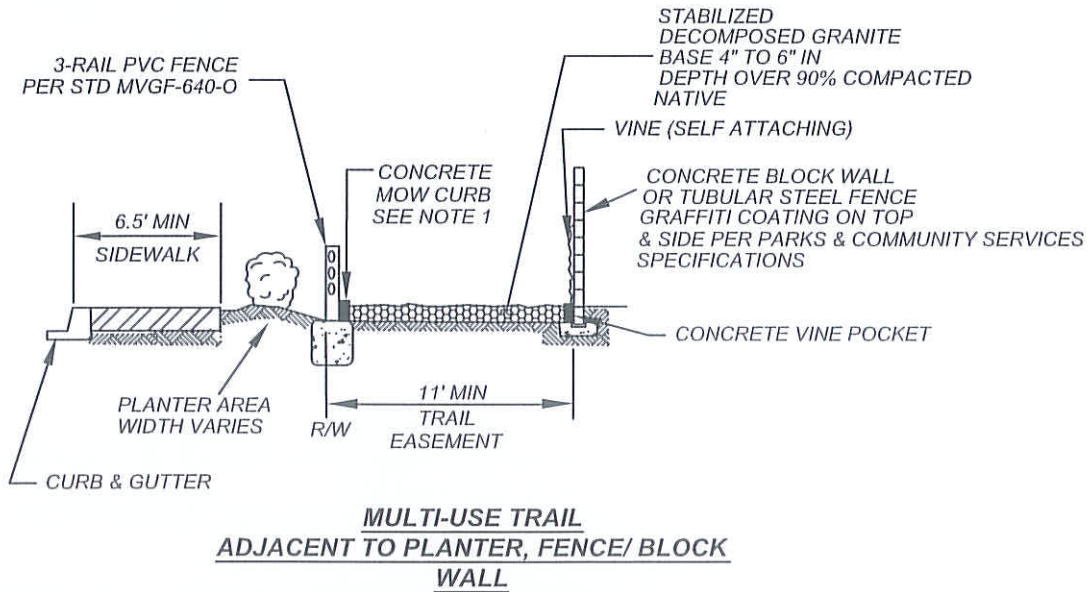

**NOTES:**

- 1.) CONCRETE MOW CURB REQUIRED NEXT TO LANDSCAPE AREAS (REFER TO STANDARD MVLI-522B-0 FOR MOW CURB DETAIL).
- 2.) CONCRETE VINE POCKET REQUIRED TO PROTECT VINE.

NOT TO SCALE

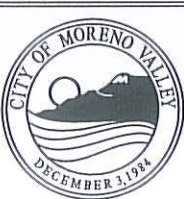

RECOMMENDED:  
*[Signature]* 1/21/14  
 DIVISION MANAGER DATE

APPROVED:  
*[Signature]* 1/29/14  
 PUBLIC WORKS DIRECTOR/ DATE  
 CITY ENGINEER

**CITY OF MORENO VALLEY**  
 PARKS AND COMMUNITY SERVICES DEPARTMENT

**MULTI-USE TRAIL**

STANDARD PLAN  
**MVGF-610G-0**

SHEET 7 OF 14

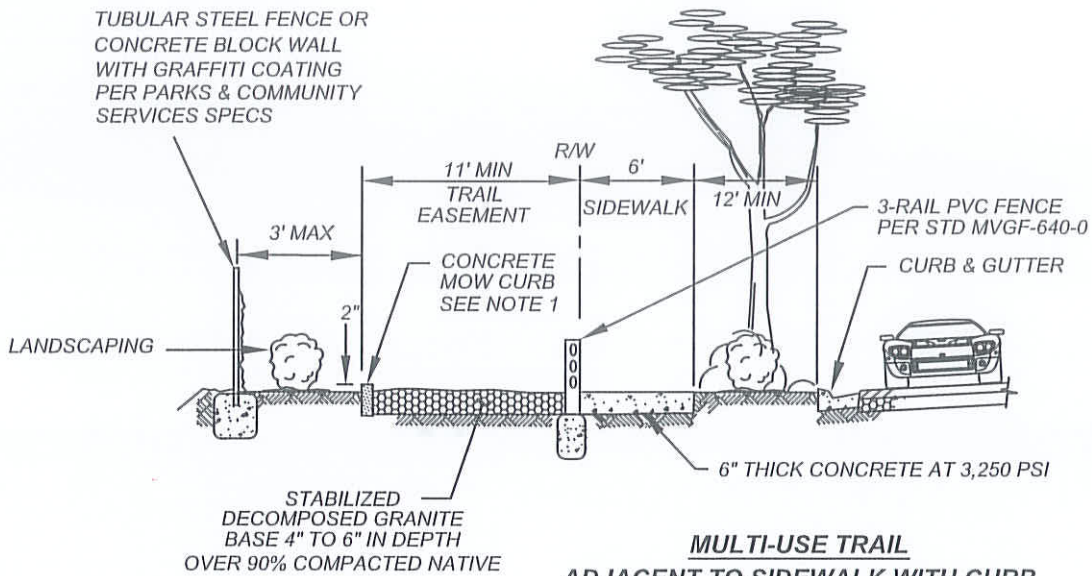

**MULTI-USE TRAIL  
ADJACENT TO SIDEWALK WITH CURB  
ADJACENT PLANTER**

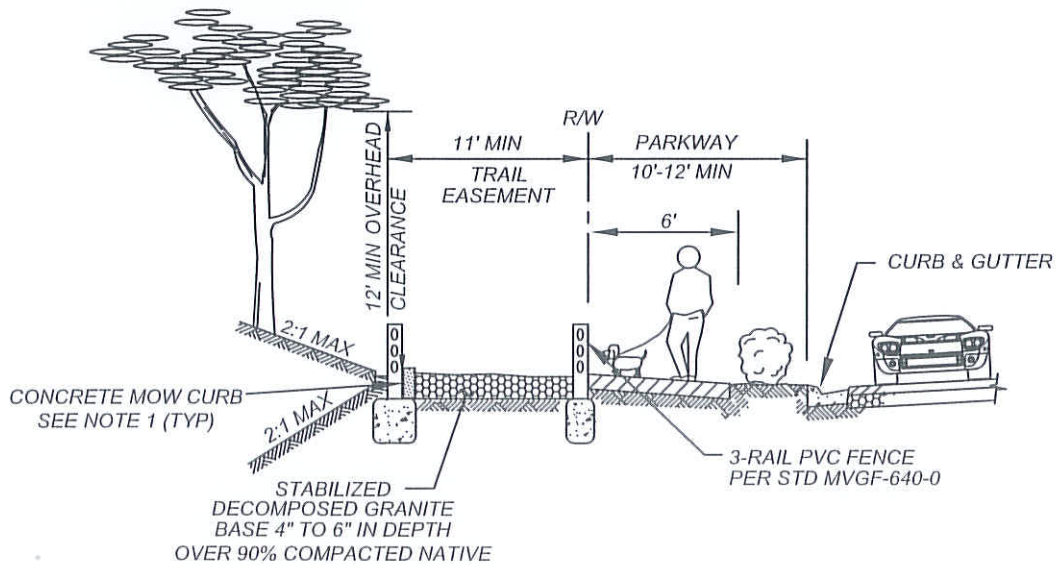

**MULTI-USE TRAIL  
ADJACENT TO STREET WITH SIDEWALK**

**NOTES:**

- 1.) CONCRETE MOW CURB REQUIRED NEXT TO LANDSCAPE AREAS (REFER TO STANDARD MVLI-522B-0 FOR MOW CURB DETAIL).

NOT TO SCALE

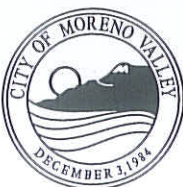

RECOMMENDED: *[Signature]* 1/21/14  
DIVISION MANAGER DATE

APPROVED: *[Signature]* 1/29/14  
PUBLIC WORKS DIRECTOR / DATE  
CITY ENGINEER

**CITY OF MORENO VALLEY**  
PARKS AND COMMUNITY SERVICES DEPARTMENT

**MULTI-USE TRAIL**

STANDARD PLAN  
**MVGF-610H-0**

SHEET 8 OF 14

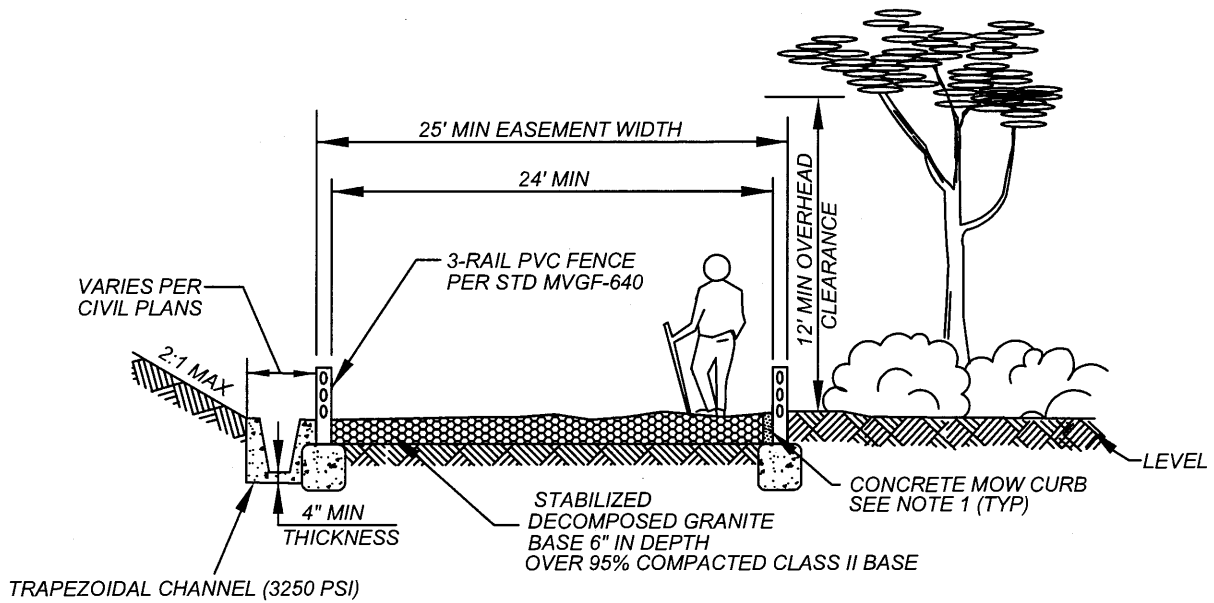

**MULTI-USE TRAIL WITH FIRE ACCESS**

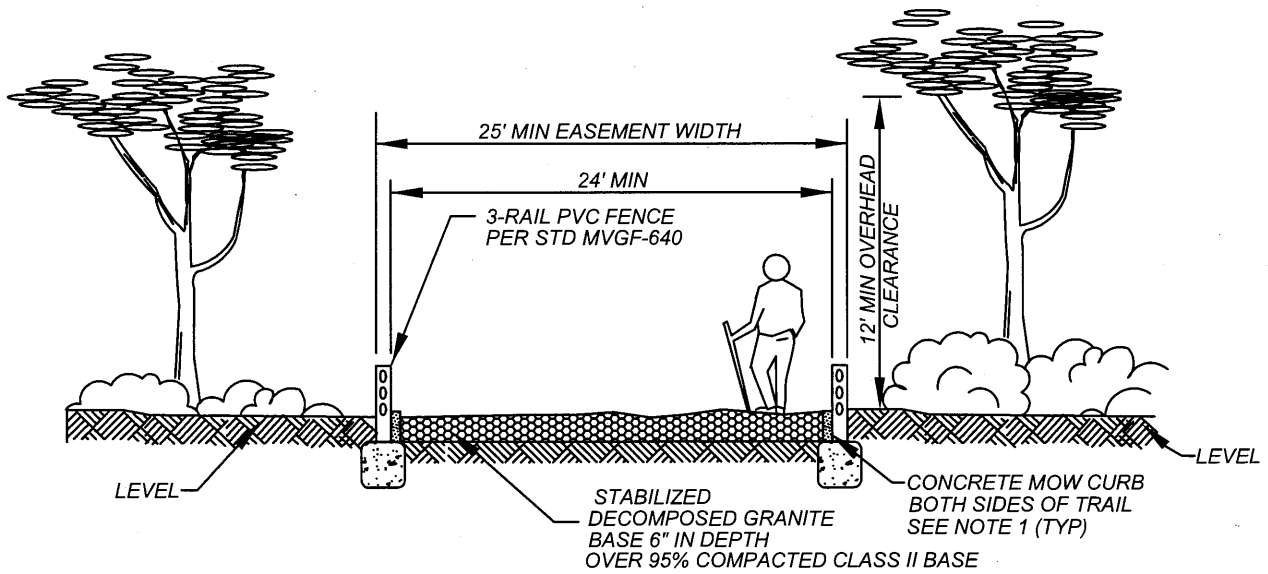



**MULTI-USE TRAIL WITH FIRE ACCESS**

**NOTES:**

- 1.) CONCRETE MOW CURB REQUIRED NEXT TO LANDSCAPE AREAS (REFER TO STANDARD MVLI-522B FOR MOW CURB DETAIL).
- 2.) ALL CONCRETE SHALL BE 560C-3250, DAVIS OMAHA TAN.

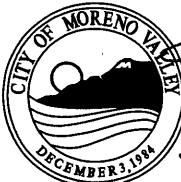
NOT TO SCALE

	RECOMMENDED:  DIVISION MANAGER DATE 12/27/16	<b>CITY OF MORENO VALLEY</b> PARKS AND COMMUNITY SERVICES DEPARTMENT	
	APPROVED:  PUBLIC WORKS DIRECTOR / DATE CITY ENGINEER 1/20/17	<b>MULTI-USE TRAIL</b>	



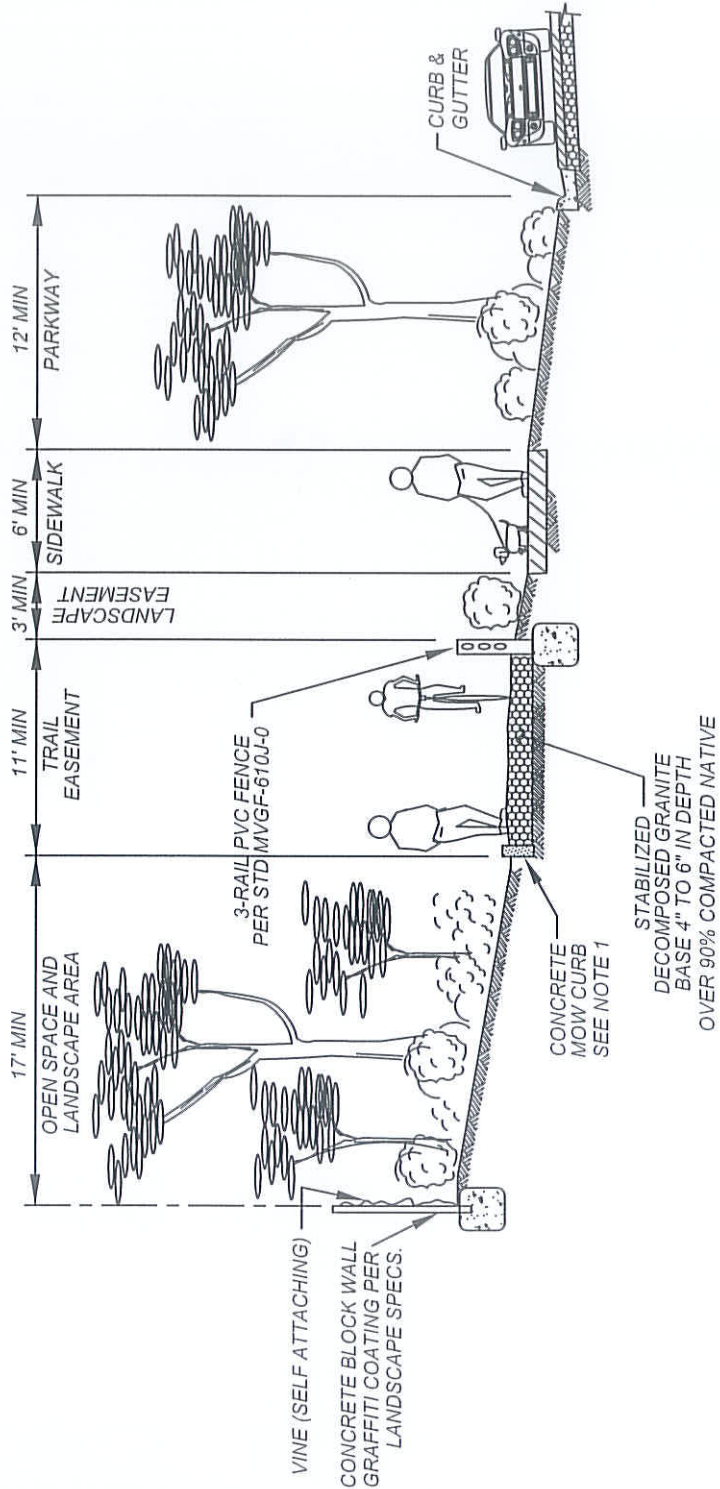

**MULTI-USE TRAIL  
TRAIL, SIDEWALK, LANDSCAPE AREA AND  
PARKWAY COMBINATION**

**NOTES:**  
1.) CONCRETE MOW CURB REQUIRED NEXT TO LANDSCAPE AREAS (REFER TO STANDARD MVL-522B-0 FOR MOW CURB DETAIL).

NOT TO SCALE

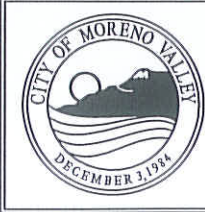

RECOMMENDED:  
*[Signature]* / 1/21/14  
DIVISION MANAGER / DATE

APPROVED:  
*[Signature]* / 1/29/14  
PUBLIC WORKS DIRECTOR / DATE  
CITY ENGINEER

**CITY OF MORENO VALLEY**  
PARKS AND COMMUNITY SERVICES DEPARTMENT

**MULTI-USE TRAIL**

STANDARD PLAN  
**MVGF-610J-0**  
SHEET 10 OF 14



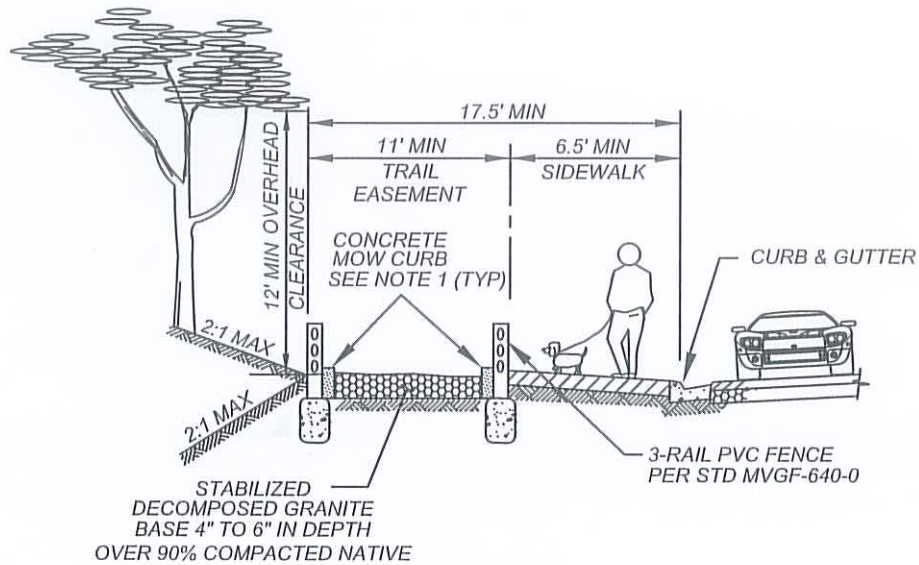

**MULTI-USE TRAIL  
ADJACENT TO STREET WITH SIDEWALK**

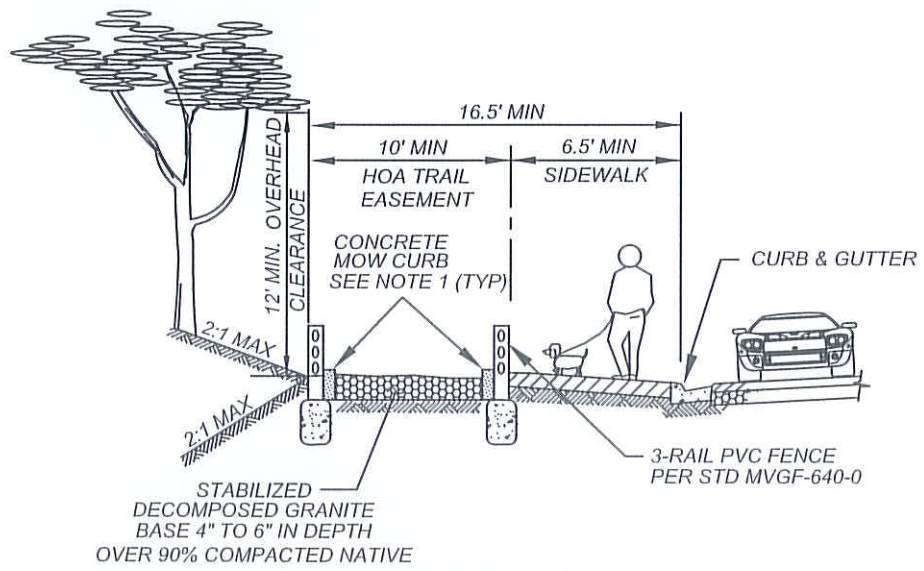



**HOA MULTI-USE TRAIL  
ADJACENT TO STREET WITH SIDEWALK**

**NOTES:**

1.) CONCRETE MOW CURB REQUIRED NEXT TO LANDSCAPE AREAS (REFER TO STANDARD MVLI-522B-0 FOR MOW CURB DETAIL).

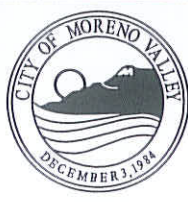
NOT TO SCALE

	RECOMMENDED:  1/21/14 DIVISION MANAGER DATE	<b>CITY OF MORENO VALLEY</b> PARKS AND COMMUNITY SERVICES DEPARTMENT	
	APPROVED:  1/29/14 PUBLIC WORKS DIRECTOR / DATE CITY ENGINEER		
		<b>MULTI-USE TRAIL</b>	SHEET 11 OF 14

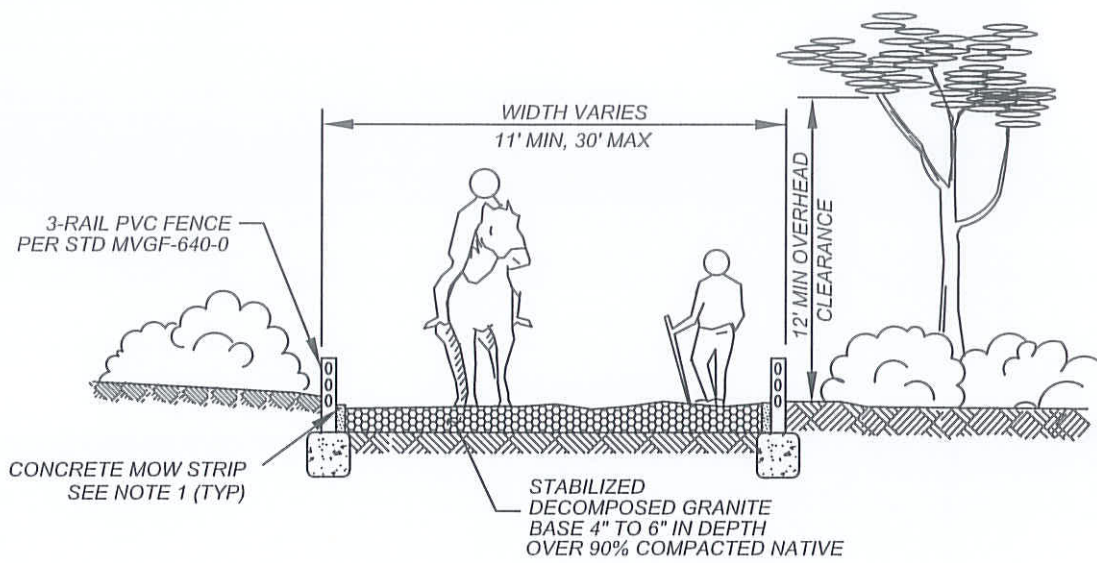

**PRIMARY RIDING AND HIKING TRAIL - I**

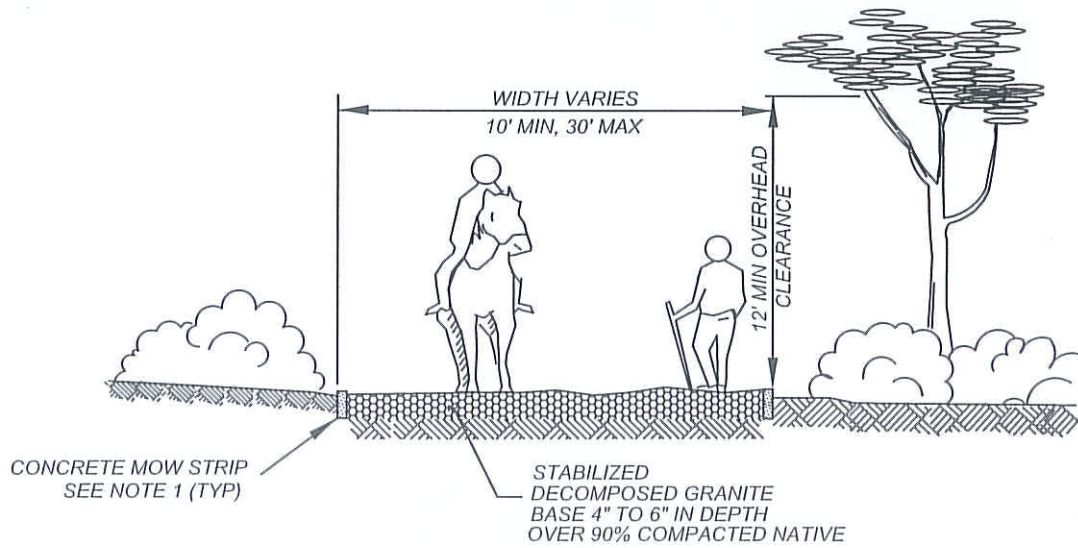



**PRIMARY RIDING AND HIKING TRAIL - II**

**NOTES:**

- 1.) CONCRETE MOW STRIP REQUIRED NEXT TO LANDSCAPE AREAS (REFER TO STANDARD MVLI-522B-0 FOR MOW CURB DETAIL).

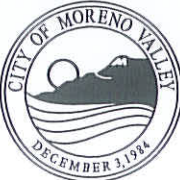
NOT TO SCALE

	RECOMMENDED:  DIVISION MANAGER / DATE	<b>CITY OF MORENO VALLEY</b> PARKS AND COMMUNITY SERVICES DEPARTMENT  <b>RIDING AND HIKING TRAILS</b>	STANDARD PLAN <b>MVGF-610L-0</b>
	APPROVED:  PUBLIC WORKS DIRECTOR / DATE CITY ENGINEER		SHEET 12 OF 14



**TRAIL WIDTH, FENCING, AND GATE:**

- MINIMUM TRAIL WIDTH SHALL BE 10' (INSIDE POSTS). WHERE FIRE DEPARTMENT ACCESS IS NECESSARY, TRAIL SHALL BE A MINIMUM OF 20' WIDE. TRAIL IS DEFINED AS MINIMUM SURFACE AREA WITHOUT OBSTRUCTIONS (FENCE POSTS, "V" DITCH, ETC.).
- 3-RAIL PVC FENCE SHALL BE PER STD MVGF-640-0.
- EQUESTRIAN FENCING SHALL BE INSTALLED ON BOTH SIDES OF TRAIL, UNLESS A WALL OR OTHER APPROVED FENCING IS INSTALLED ON ONE SIDE.
- EQUESTRIAN TRAILHEADS SHALL BE UTILIZED WHEN A TRAIL TERMINATES AT PUBLIC STREET OR HIGHWAY, WHERE SPECIFIED. THE ROUGH DIMENSIONS FOR EQUESTRIAN SWITCHBACKS ARE 5x10'. SEE STANDARD PLAN MVGF-613A-0 AND INSTALL AS REQUIRED. A 'STOP' SIGN SHALL BE INSTALLED AT ALL LOCATIONS THAT EXIT ONTO A ROADWAY, WHERE REQUIRED. A CITY SUPPLIED TRAIL SIGN SHALL BE INSTALLED ON ALL TRAIL ENTRANCES. SIGN AND POST SPECIFICATIONS ARE TO ADHERE TO THE CITY'S STANDARD PLANS. ALL POSTS SHALL BE SUPPLIED BY THE CONTRACTOR.
- THE TRAIL AND FENCING SHALL CONNECT WITH ADJACENT TRAILS.
- THREE CABLE RAILING MAY BE REQUIRED IN SOME AREAS AND SHALL BE PER STD MVGF-616-0.
- GATES ARE REQUIRED IN LOCATIONS WHERE FIRE AND/OR MAINTENANCE ACCESS IS DESIGNATED. GATES FOR OPENINGS SHALL BE CONSTRUCTED OF HOT DIPPED GALVANIZED STEEL PIPE. SINGLE GATE WIDTH IS NOT TO EXCEED 16'. GATE OPENINGS IN EXCESS OF 16' SHALL BE EQUAL SIZED DOUBLE GATES WITH A SLEEVED REMOVABLE POST. THE GATES SHALL BE EQUIPPED WITH A HEAVY DUTY CHAIN (ADDITIONAL CHAIN SECTIONS REQUIRED WHERE MULTIPLE LOCKS ARE USED) AND A REMOVABLE LATCH POST WITH A GATE STOP. THE REMOVABLE LATCH POST SHALL HAVE A CHAIN WELDED TO BOTH THE POST AND THE SLEEVE FOR SECURING BY AN APPROVED PADLOCK. ADDITIONALLY, THE CENTER POST IS TO HAVE A DOMED CAP INSTALLED. ALL GATES ARE TO BE EQUIPPED WITH A PARKS AND COMMUNITY SERVICES APPROVED KNOX BOX. THESE ITEMS ARE TO BE WELDED TO FRAME ON A 1/4" THICK GALVANIZED PLATE. ALL GATE POSTS, WITH THE EXCEPTION OF THE CENTER POST SHALL BE FILLED WITH CONCRETE AND DOME CAPPED. FRAMES SHALL HAVE MITERED CORNERS AND THE CENTER RAIL SHALL BE CUT TO FIT INTO THE FRAME. PVC FENCE MATERIAL SHALL BE SECURELY ATTACHED TO THE GATE FRAME AND RAILS. GATES SHALL HAVE A 12" x 18" 'NO STOPPING - FIRE LANE' SIGN SECURELY ATTACHED.

**MASONRY:**

- THE SIDE OF THE TRAIL OR ACCESS POINTS THAT ARE ADJACENT TO RESIDENCES SHALL CONTAIN FENCING CONSTRUCTED OF DECORATIVE CONCRETE BLOCK OR DECORATIVE CONCRETE BLOCK / ORNAMENTAL IRON WITH A MINIMUM HEIGHT OF 72". SLUMP STONE AND SPLIT FACED BLOCK SHALL BE TAN MORTAR AND HAVE A PRECAST WALL CAP. ALL WALLS SHALL BE SOLID GROUTED. THE CONCRETE BLOCK DESIGN AND COLOR SHALL BE APPROVED BY THE DIRECTOR OF PARKS AND COMMUNITY SERVICES OR HIS / HER DESIGNEE. FENCING/WALLS SHALL BE INSTALLED ON RESIDENTS' OR HOMEOWNERS ASSOCIATION PROPERTY. RETAINING WALLS SHALL ADHERE TO THE SAME SPECIFICATIONS AS LISTED ABOVE.
- ALL DECORATIVE MASONRY WALLS ADJACENT TO TRAILS AND THEIR ENTRANCES SHALL BE ANTIGRAFFITI COATED PER PARKS SPECIFICATIONS. FOLLOW MANUFACTURER'S DIRECTIONS FOR APPLICATION. ANY REQUESTED PRODUCT DEVIANCE REQUIRE A PRODUCT SPECIFICATION SHEET AND A FINISHED SAMPLE OF THE PRODUCT AND THIRD PARTY TESTING. THEY SHALL BE SUBMITTED TO THE DIRECTOR OF PARKS AND COMMUNITY SERVICES OR HIS/HER DESIGNEE FOR WRITTEN APPROVAL PRIOR TO INSTALLATION.

**CONCRETE:**

- ALL CONCRETE SHALL BE IN ACCORDANCE TO "GREENBOOK" STANDARD SPECIFICATION FOR PUBLIC WORKS CONSTRUCTION, SECTION 201. COPIES OF ALL LOAD TICKETS ARE REQUIRED TO BE SUBMITTED TO THE PARKS AND COMMUNITY SERVICES WEEKLY OR UPON IMMEDIATE REQUEST.
- ALL CONCRETE FOR TRAPEZOIDAL CHANNEL, 'V' OR BROW DITCHES, CATCH BASINS, SWALES, RETAINING WALLS, CHANNELS, DRIVE APPROACHES, AND OTHER FLAT WORK SHALL BE INTEGRALLY MIXED WITH DAVIS COLORS CONCENTRATED PIGMENTS AT THE RATE SPECIFIED BY THE MANUFACTURER. THE COLOR SHALL BE "OMAHA TAN". FINISHES SHALL BE PER PLAN. COLORED CONCRETE SHALL BE CURED WITH DAVIS W-1000 CLEAR SPRAY-ON MEMBRANE. ANY REQUESTED COLOR DEVIANCE REQUIRE A COLOR CHART SUBMITTAL, PRODUCT SPECIFICATION, AND A FINISHED SAMPLE OF THE PRODUCT SUBMITTED TO THE DIRECTOR OF PARKS AND COMMUNITY SERVICES OR HIS/HER DESIGNEE FOR WRITTEN APPROVAL PRIOR TO ANY TRAIL CONSTRUCTION.
- TRAPEZOIDAL CHANNEL AND "V" OR BROW DITCH SHALL BE SEPARATED FROM THE TRAIL BY PVC, CHAIN LINK, OR 3-CABLE FENCING.
- CONCRETE DRIVEWAYS / APPROACHES TO TRAILS SHALL BE CONSTRUCTED 8"-THICK, 560C-3250 (3250 PSI), MAXIMUM 4" SLUMP, WITH #4 REBAR TIED 18" O.C. IF A PUMP CONCRETE MIX IS UTILIZED IT SHALL BE CLASS 660C-4000P (4000 PSI). THE FINISH SHALL BE TINE NON-SLIP SURFACE; COLOR SHALL BE DAVIS COLORS "OMAHA TAN", UNLESS AUTHORIZED OTHERWISE IN WRITING BY PARKS AND COMMUNITY SERVICES. ALL JOINTS SHALL BE DEEP TROWEL.
- DRIVEWAYS SHALL BE LABELED 'NO PARKING FIRE LANE', 12" HIGH, WITH RED PAINT, AT MAXIMUM OF 12' FROM CURB FACE.

NOT TO SCALE

	RECOMMENDED:  DIVISION MANAGER      DATE	CITY OF MORENO VALLEY PARKS AND COMMUNITY SERVICES DEPARTMENT	
	APPROVED:  PUBLIC WORKS DIRECTOR / DATE CITY ENGINEER		

**CITY OF MORENO VALLEY**

PARKS AND COMMUNITY SERVICES DEPARTMENT

**MULTI-USE TRAIL SPECIFICATIONS**

STANDARD PLAN  
**MVGF-610M-0**

SHEET 13 OF 14

**DRAWINGS AND INSPECTIONS:**

- ALL CONSTRUCTION DRAWINGS MUST BE SUBMITTED TO THE DIRECTOR OF PARKS AND COMMUNITY SERVICES OR HIS/HER DESIGNEE AND APPROVED BEFORE CONSTRUCTION BEGINS.
- ALL CHANGES SHALL BE "REDLINED" AND APPROVED BY THE DIRECTOR OF PARKS AND COMMUNITY SERVICES OR HIS/HER DESIGNEE AND THE ARCHITECT BEFORE THEY ARE MADE.
- MATERIAL SUBMITTALS SHALL BE SUBMITTED AND APPROVED BY THE DIRECTOR OF PARKS AND COMMUNITY SERVICES OR HIS/HER DESIGNEE PRIOR TO COMMENCEMENT OF THE PROJECT.
- THE DEVELOPER / CONTRACTOR SHALL SUBMIT TO THE DIRECTOR OF PARKS AND COMMUNITY SERVICES OR HIS/HER DESIGNEE SIX (6) FULL SETS OF "AS-BUILT" DRAWINGS AND ONE (1) MYLAR WITH HANGING TABS BEFORE THE PROJECT IS RELEASED. THE DESIGNING ARCHITECT SHALL COMPLETE THE DRAWINGS.
- INSPECTION NOTICES FOR ALL PARK AND COMMUNITY SERVICES DEPARTMENT RELATED CONSTRUCTION SHALL BE A MINIMUM OF 48 HOURS IN ADVANCE. INSPECTIONS SHALL BE COORDINATED UPON GRADING, FENCE INSTALLATION, CONCRETE INSTALLATION, DECOMPOSED GRANITE INSTALLATION, AND FINAL ACCEPTANCE. PHONE 951.413.3701.
- THE CONTRACTOR MAY OFFER ANY MATERIAL CONSIDERED TO BE EQUIVALENT TO THAT INDICATED. THE SUBSTANTIATION OF OFFERS SHALL BE SUBMITTED IN WRITING AND APPROVED IN WRITING BY THE PARKS AND COMMUNITY SERVICES DEPARTMENT.

**TRAIL SURFACE:**

- ALL PLAN DETAILS ARE REQUIRED TO SHOW CROSS SECTIONS OF THE TRAIL. THE TRAIL CROSS SECTIONS MUST REFLECT AND INDICATE THE VARIOUS GRADE CHANGES ALONG THE LENGTH OF THE TRAIL. TRAILS SHALL NOT EXCEED A 10% GRADE IN THE DIRECTION OF TRAVEL AND HAVE A MAXIMUM 2% CROSS SLOPE. THE DIRECTOR OF PARKS AND COMMUNITY SERVICES OR HIS/HER DESIGNEE SHALL APPROVE ANY GRADE CHANGES IN WRITING BEFORE PLANS ARE APPROVED AND CONSTRUCTION COMMENCES. ALL LANDINGS SHALL BE GRADUALLY INCORPORATED INTO THE GRADE, IN ORDER TO ALLOW LARGE VEHICLES EASY TRANSITION. ALL DETAILS AND GRADES FOR THE TRAIL SHALL BE REVIEWED AND APPROVED BY THE DIRECTOR OF PARKS AND COMMUNITY SERVICES OR HIS/HER DESIGNEE PRIOR TO ANY TRAIL CONSTRUCTION.
- WHERE TRAILS ARE ADJACENT AND LEVEL TO LANDSCAPE AREAS OR OPEN SPACE, THE STABILIZED DECOMPOSED GRANITE SHALL BE CONFINED IN TRAIL BY THE USE OF A 6"x6" (MINIMUM) CONCRETE HEADER WITH #4 REBAR REINFORCEMENT. THE CONCRETE SPECIFICATION SHALL BE "GREENBOOK" CLASS 560-C-3250 OR 660-C-4000P (PUMP MIX), WITH NO SUBSTITUTIONS FOR PORTLAND CEMENT. THE COLOR SHALL BE DAVIS OMAHA TAN. ADDITIONALLY, THIS SPECIFICATION PERTAINS TO VINE POCKETS.

**STABILIZED DECOMPOSED GRANITE AND INSTALLATION PROCEDURES:**

1. GREENBOOK STANDARD SPECIFICATIONS FOR PUBLIC WORKS CONSTRUCTION: STANDARDS 400-2.2 AND 200-2.7
2. GRADATION: AS DETERMINED BY ASTM C 136 METHODOLOGY (CALTRANS 202)
 

SIEVE SIZE	PERCENT PASSING
1/2"	100
3/8"	90-100
No 4	50-100
No 30	25-55
No 100	10-20
No 200	5-18
3. SAND EQUIVALENT : AS DETERMINED BY ASTM D 2419 METHODOLOGY (CALTRANS 217): MINIMUM OF 30.
4. R-VALUE: AS DETERMINED BY ASTM D 2488 METHODOLOGY (CALTRANS 301): MINIMUM OF 70.
5. DECOMPOSED GRANITE AS SPECIFIED IN THE CITY STANDARD PLANS SHALL BE DERIVED FROM THE CRUSHING AND SCREENING OF NATURALLY FRIABLE GRANITE. THE BLENDING OF COURSE SAND WITH ROCK DUST IS NOT PERMITTED. THE GRANITE IS SCREENED TO INCLUDE STONE PARTICLES OF 1/2" MINUS. THE PARTICLES THAT PASS THE 200 SCREEN MESH AS DETERMINED BY ASTM METHODOLOGY SHALL NOT EXCEED 18 PERCENT. THE SAND EQUIVALENT SHALL BE A MINIMUM OF 30 AND THE R-VALUE SHALL BE A MINIMUM OF 70.
6. STABILIZING BINDER SHALL BE APPROVED BY THE CITY. THE BINDER SHALL BE INCORPORATED WITH THE GRANITE FINES BY THE USE OF A PUG MILL THAT INCLUDES A WEIGHT BELT FEEDER THAT INSURES THE PROPER RATIO OF BINDER TO GRANITE FINES. BLENDING WITH THE USE OF A BUCKET LOADER OR SIMILAR IS NOT ACCEPTABLE. FOR TRAILS AND STAGING AREAS THE BINDER SHALL BE BLENDED AT THE RATE SPECIFIED FOR TYPE OF USE. THE MIXING FACILITY AND MIXING METHOD SHALL BE AVAILABLE TO THE CITY FOR INSPECTION UPON REQUEST. STABILIZING BINDER SHALL BE NEXPAVE ORGANIC LOCK, NEXPAVE WAX, OR APPROVED EQUAL.
7. STABILIZED DECOMPOSED GRANITE SHALL BE PLACED TO A MINIMUM DEPTH OF 4"-6" COMPACTED, PER PLAN.
8. INSTALLATION: FOR EACH 2" LIFT EVENLY SPREAD THE MATERIAL OVER AREA ACCORDING TO PLANS. GRADE AND SMOOTH AS DIRECTED BY THE INSPECTOR. THOROUGHLY WATER ENTIRE AREA SO THAT THE ENTIRE DEPTH OF THE MATERIAL IS MOIST. A HIGH VOLUME WATER TRUCK IS RECOMMENDED. AFTER A PERIOD OF +/- 6 HOURS COMPACT THE FINAL LIFT WITH A 1000 - 3000 lb STATIC DRUM ROLLER. ALLOW FOR A SUFFICIENT CURING PERIOD OF +/- 4 DAYS PRIOR TO USE.
9. THIRD-PARTY TESTING OF MATERIALS AND/OR INSTALLATION MAYBE REQUESTED BY THE CITY. THE TESTING SHALL BE PERFORMED WITH NO COST TO THE CITY.
10. FIRE LANE TRAILS SHALL HAVE 6" STABILIZED DG OVER 6" CLASS II BASE, COMPACTED 95%.

NOT TO SCALE

	RECOMMENDED:  DIVISION MANAGER      DATE:	<h2 style="margin: 0;">CITY OF MORENO VALLEY</h2> <p style="margin: 0;">PARKS AND COMMUNITY SERVICES DEPARTMENT</p>	STANDARD PLAN <h3 style="margin: 0;">MVGF-610N-1</h3>
	APPROVED:  PUBLIC WORKS DIRECTOR / DATE CITY ENGINEER	<h3 style="margin: 0;">MULTI-USE TRAIL SPECIFICATIONS</h3>	SHEET 14 OF 14



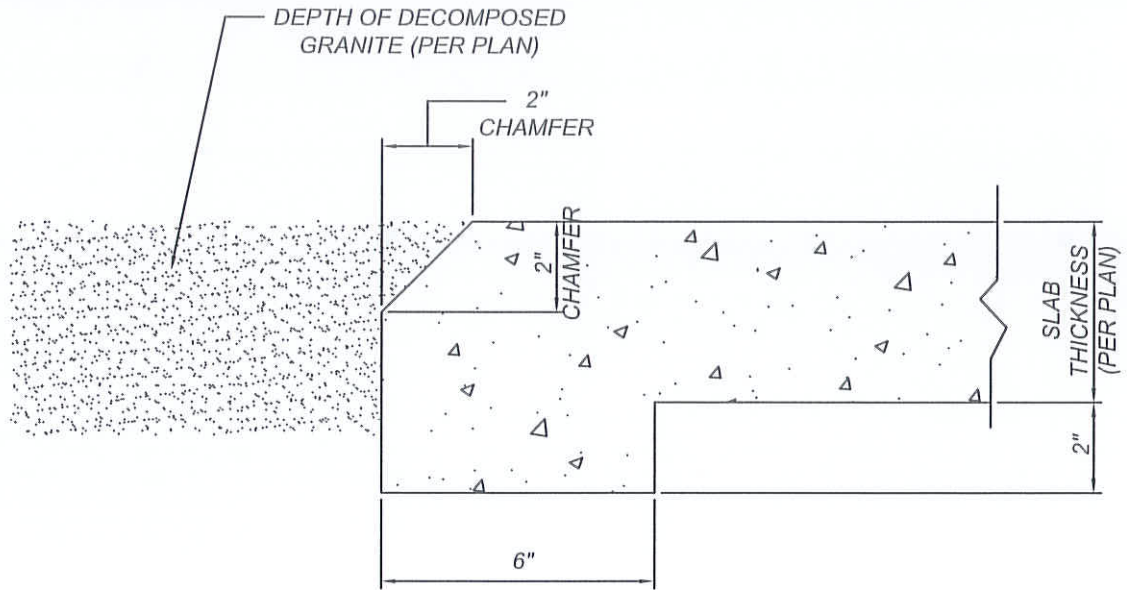

NOT TO SCALE

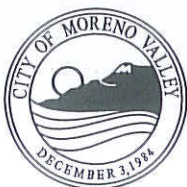

RECOMMENDED:  
*[Signature]* 11/21/14  
 DIVISION MANAGER DATE

APPROVED:  
*[Signature]* 1/29/14  
 PUBLIC WORKS DIRECTOR / DATE  
 CITY ENGINEER

# CITY OF MORENO VALLEY

PARKS AND COMMUNITY SERVICES DEPARTMENT

## CONCRETE WALK / SLAB / APPROACH ADJACENT TO TRAIL

STANDARD PLAN  
**MVGF-611-0**

SHEET 1 OF 1

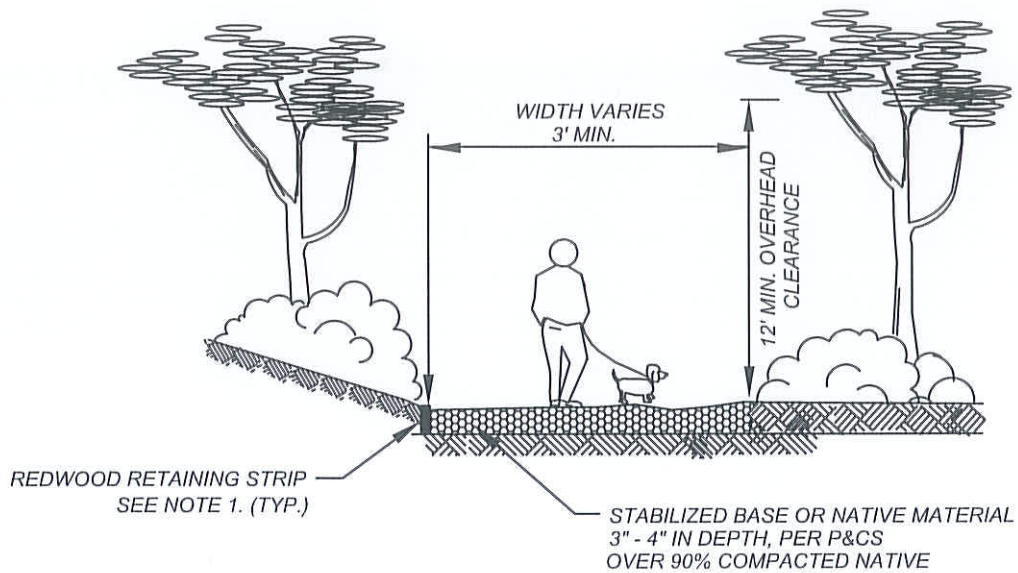



**SECONDARY RIDING AND HIKING TRAIL**  
**FOR HOA HILL SIDE AREAS**

**NOTES:**

1.) 2" X 4" REDWOOD RETAINING STRIP AS REQUIRED NEXT TO LANDSCAPED AREAS AND SLOPES. STAKES SHALL BE INSTALLED AT 2' INTERVALS. DOUBLE STAKE ENDS.

NOT TO SCALE

	RECOMMENDED:  1/21/14 DIVISION MANAGER      DATE	<b>CITY OF MORENO VALLEY</b> PARKS AND COMMUNITY SERVICES DEPARTMENT	STANDARD PLAN
	APPROVED:  1/29/14 PUBLIC WORKS DIRECTOR / DATE CITY ENGINEER		<b>SECONDARY RIDING AND HIKING TRAIL</b>

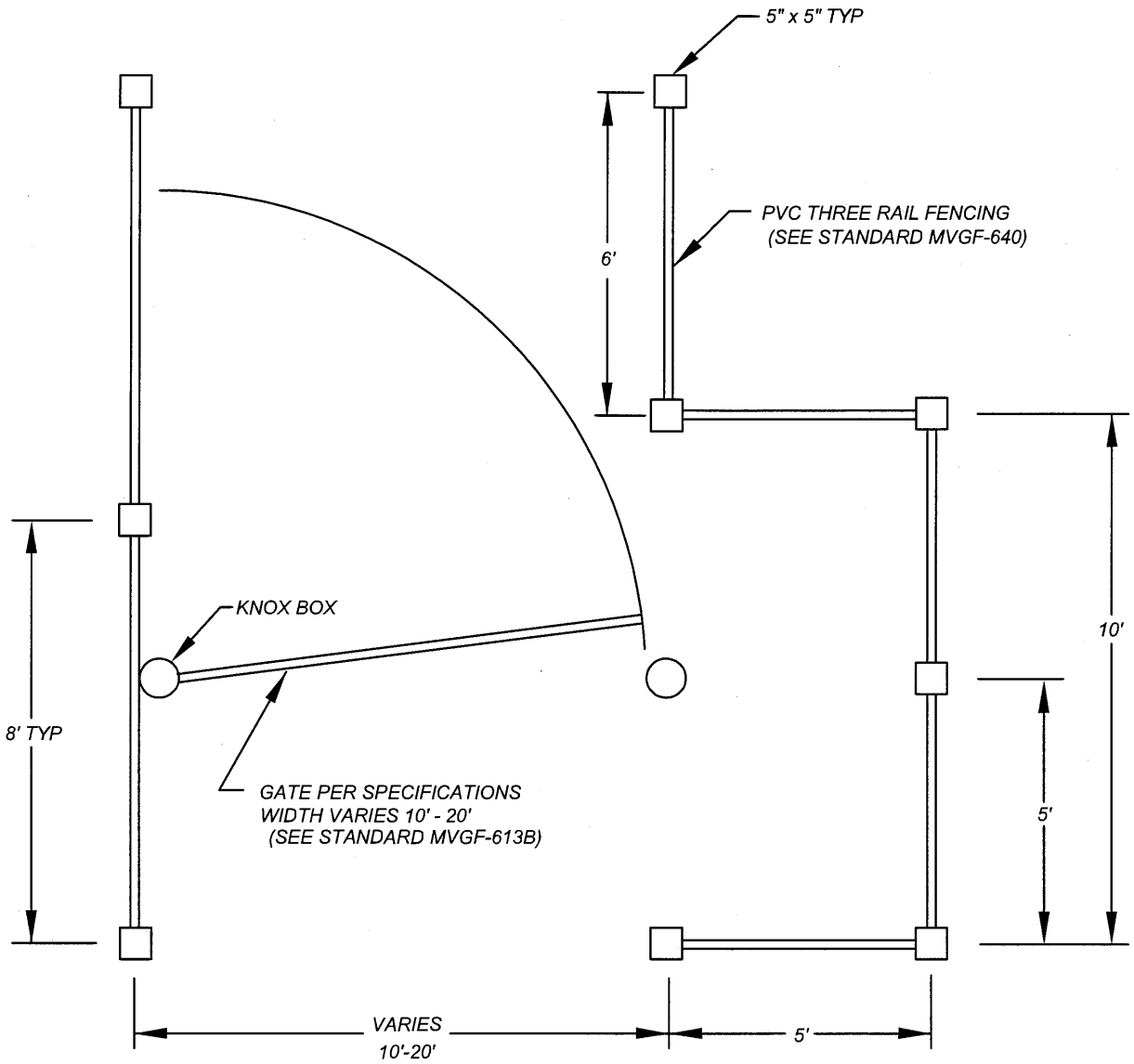

**TRAIL HEAD WITH WALK AROUND**

NOT TO SCALE

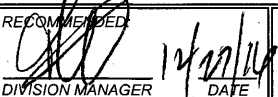
	RECOMMENDED:  DIVISION MANAGER      DATE	<b>CITY OF MORENO VALLEY</b> PARKS AND COMMUNITY SERVICES DEPARTMENT	STANDARD PLAN
	APPROVED:  PUBLIC WORKS DIRECTOR / DATE CITY ENGINEER		<b>TRAILHEAD INGRESS / EGRESS          GATE DETAIL</b>





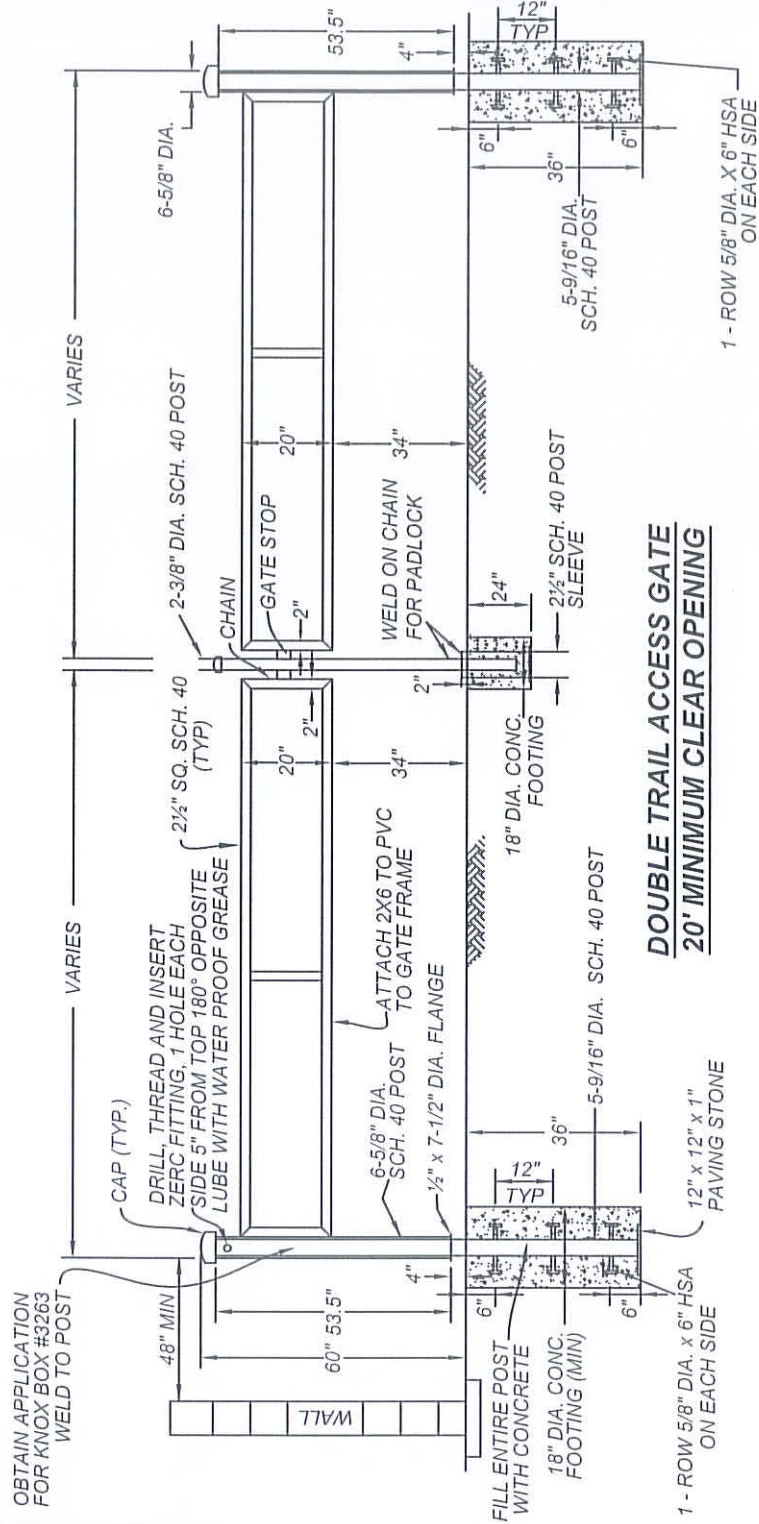

**DOUBLE TRAIL ACCESS GATE**  
**20' MINIMUM CLEAR OPENING**

**NOTES:**

- 1.) ALL METAL IS TO BE HOT DIP GALVANIZED.
- 2.) PROVIDE STOPS ON HINGE POST SO GATE DOES NOT SWING OUTWARD INTO TRAFFIC.
- 3.) TWO (2) ADDITIONAL POSTS TO BE LOCATED IN FIELD FOR HOLD OPEN POSITION.

NOT TO SCALE

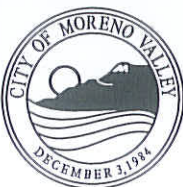

RECOMMENDED:  
  
 DIVISION MANAGER  
 DATE 11/21/14

APPROVED:  
  
 PUBLIC WORKS DIRECTOR / DATE 1/29/14  
 CITY ENGINEER

**CITY OF MORENO VALLEY**

PARKS AND COMMUNITY SERVICES DEPARTMENT

**DOUBLE TRAIL ACCESS GATE**

STANDARD PLAN  
**MVGF-613C-0**

SHEET 3 OF 5

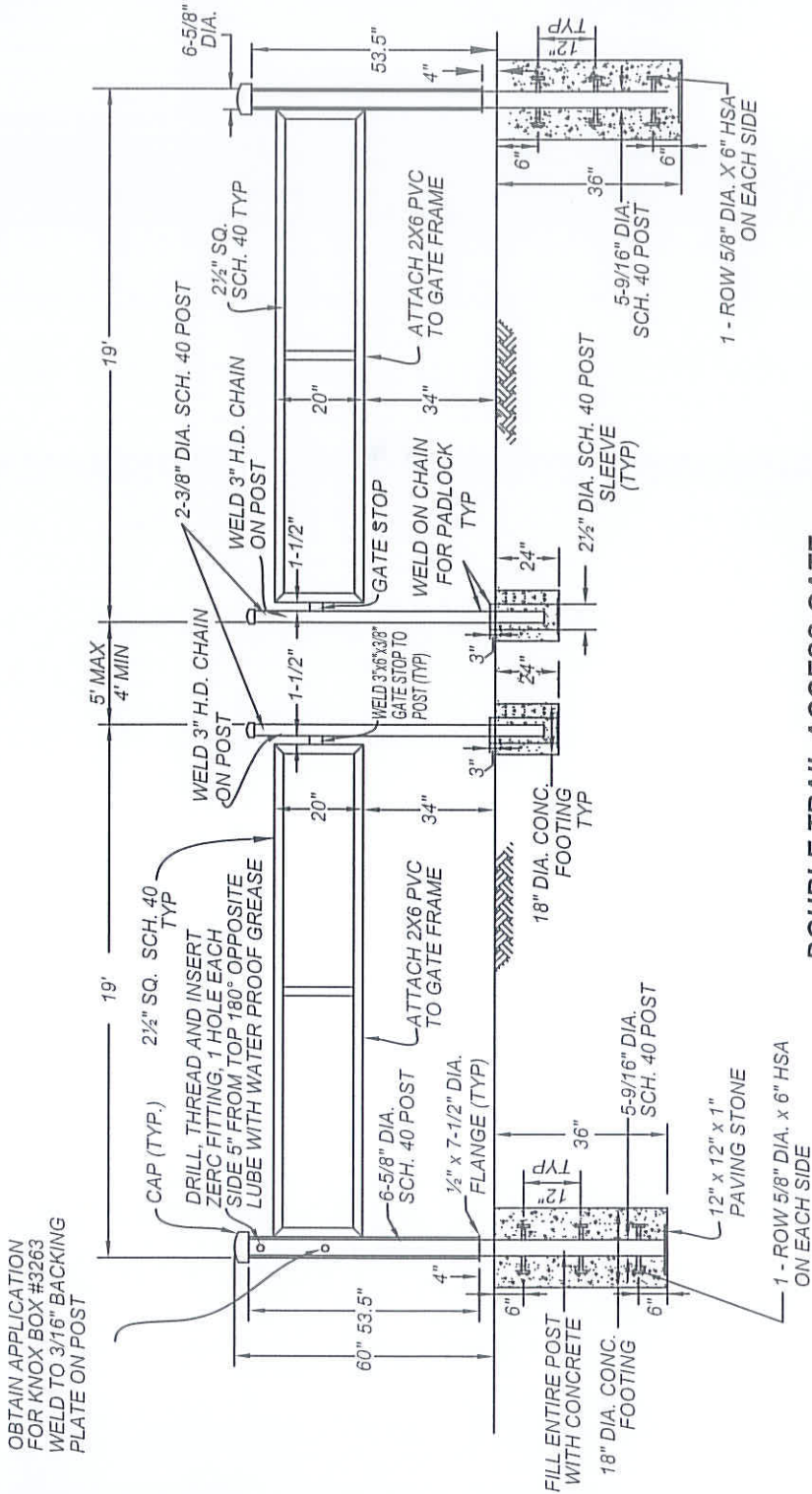



**DOUBLE TRAIL ACCESS GATE  
WITH CENTER ACCESS**

**NOTES:**

- 1.) ALL METAL IS TO BE HOT DIP GALVANIZED.
- 2.) PROVIDE STOPS ON HINGE POST SO GATE DOES NOT SWING OUTWARD INTO TRAFFIC.
- 3.) TWO (2) ADDITIONAL POSTS TO BE LOCATED IN FIELD FOR HOLD OPEN POSITION.

NOT TO SCALE



RECOMMENDED:  
  
 DIVISION MANAGER  
 DATE 1/21/14  
 APPROVED:  
  
 PUBLIC WORKS DIRECTOR/  
 CITY ENGINEER  
 DATE 1/29/14

**CITY OF MORENO VALLEY**

PARKS AND COMMUNITY SERVICES DEPARTMENT

**DOUBLE TRAIL ACCESS GATE  
WITH CENTER OPENING**

STANDARD PLAN  
**MVGF-613D-0**

SHEET 4 OF 5

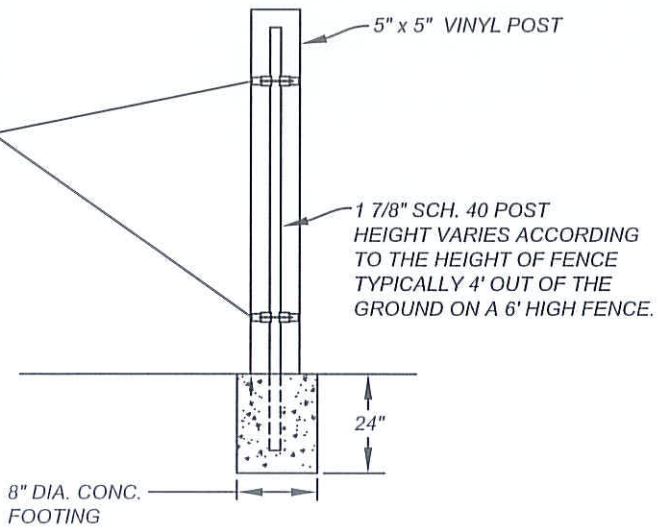
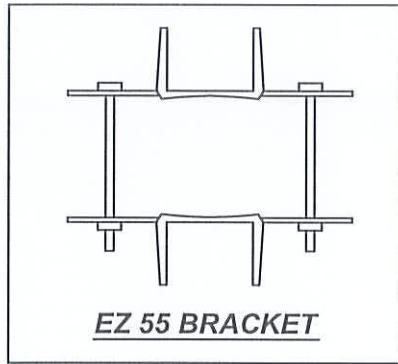

**NOTE:**

TO BE UTILIZED IN AREAS ADJACENT OR LOCATED IN CONCRETE, OR OTHERWISE REQUIRED.

NOT TO SCALE



	<p>RECOMMENDED:</p> <p><i>[Signature]</i> 1/21/14 DIVISION MANAGER DATE</p>	<p><b>CITY OF MORENO VALLEY</b> PARKS AND COMMUNITY SERVICES DEPARTMENT</p>	
	<p>APPROVED:</p> <p><i>[Signature]</i> 1/29/14 PUBLIC WORKS DIRECTOR/ DATE CITY ENGINEER</p>		
	<p><b>EZ 55 BRACKET WITH POST</b></p>		<p>SHEET 5 OF 5</p>

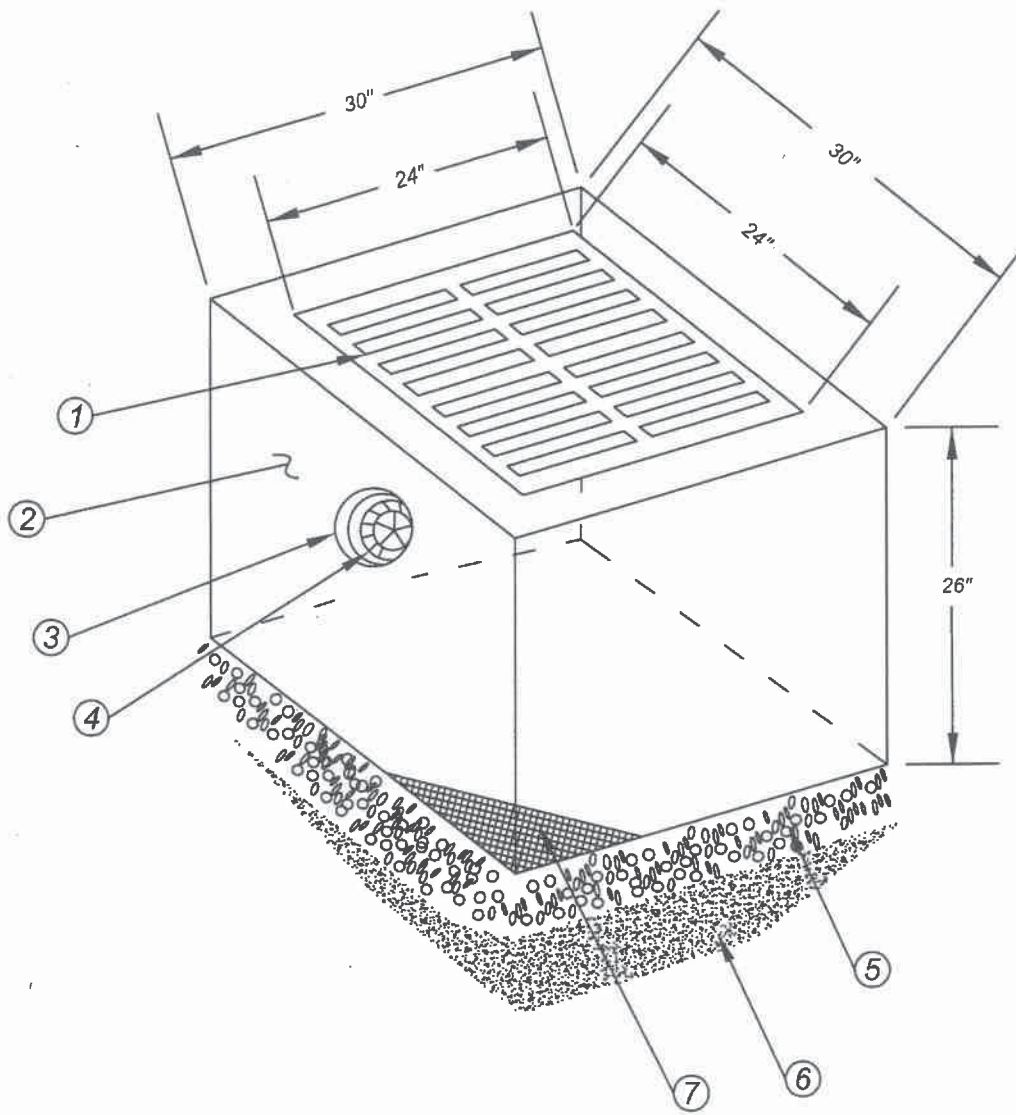



- ① TRAFFIC GRATE, DIP GALVANIZED STEEL, SECURE TO BASIN WITH 2 EA S.S. BOLT, ANCHOR, AND WASHER ON OPPOSITE SIDES
- ② TRAFFIC CATCH BASIN, 2800 PSI STEEL REINFORCED CONCRETE
- ③ 6" DIAMETER SDR 35 DRAIN PIPE AND COUPLING
- ④ 6" ATRIUM GRATE FOR SDR PIP, POLYPROPYLENE CONSTRUCTION. SECURE TO PIPE WITH S.S.SCREW
- ⑤ 12"-3/4" WASHED ROCK, COMPACTED
- ⑥ NATIVE SOIL, 95% COMPACTED
- ⑦ 1/4" STAINLESS STEEL WIRE MESH, TYPE 316. FOLD UP (6" MINIMUM) AROUND ALL SIDES OF BOX

NOT TO SCALE

	RECOMMENDED: 	6/20/19 DATE	<b>CITY OF MORENO VALLEY</b> PARKS AND COMMUNITY SERVICES DEPARTMENT	STANDARD PLAN <b>MVGF-614A-0</b>
	APPROVED: 	7/30/19 DATE	<b>24" x 24" CATCH BASIN</b>	SHEET 1 OF 2
	DIVISION MANAGER			
	PUBLIC WORKS DIRECTOR / CITY ENGINEER			



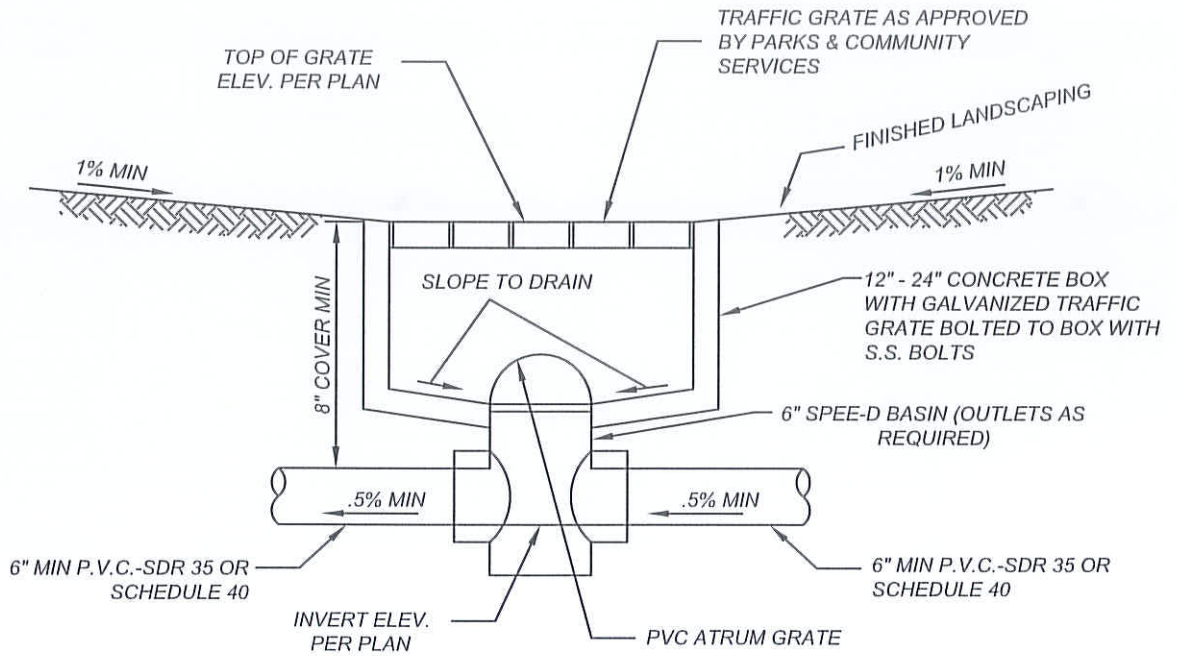



**NOTES:**

1. REFER TO FINISH LANDSCAPING DRAWING
2. DO NOT GLUE RISER TO PIPE (NEED TO BE ABLE TO REMOVE FOR MAINTENANCE PURPOSES).

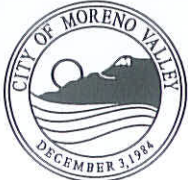
NOT TO SCALE

	RECOMMENDED:  1/21/14 DIVISION MANAGER / DATE	<b>CITY OF MORENO VALLEY</b> PARKS AND COMMUNITY SERVICES DEPARTMENT		
	APPROVED:  1/29/14 PUBLIC WORKS DIRECTOR / DATE CITY ENGINEER	<b>TYPICAL AREA DRAIN</b>		STANDARD PLAN <b>MVGF-614B-0</b>
				SHEET 2 OF 2

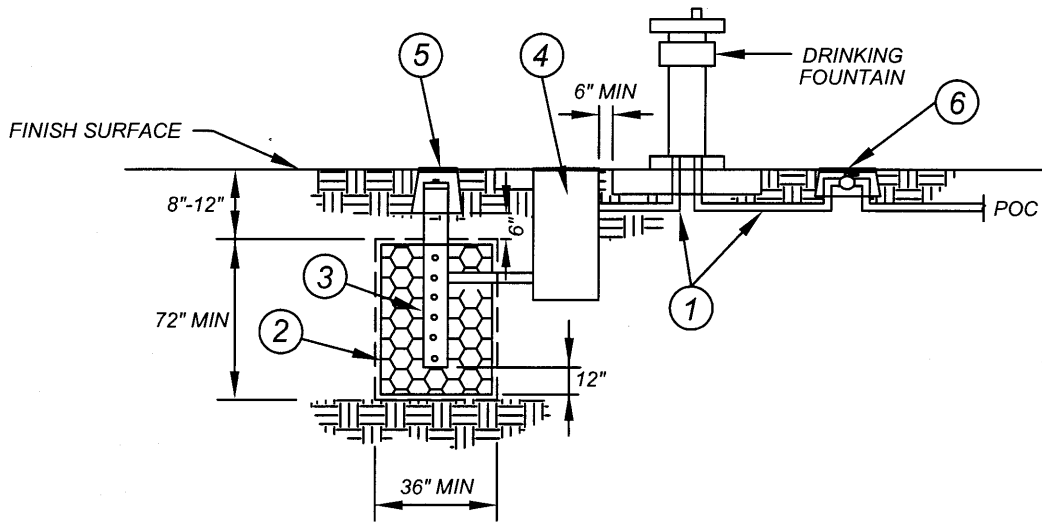

- ① INSTALL 2" SCH 80 PVC DRAIN CONNECTION FROM FOUNTAIN TO SAND TRAP. EXTEND DRAIN FROM SAND TRAP TO DISCHARGE INTO 4" PERFORATED PIPE, UTILIZING A TEE CONNECTOR, SURROUNDED BY CLEAN BROKEN ROCK.
- ② INSTALL BROKEN ROCK. (CLEAN OPEN-ENDED GRAVEL 1/2" MIN, 3/4" MAX) IN FILTER FABRIC (MIRAFI 140S OR 140N) LINED HOLE (TOP, BOTTOM, & SIDES), 36" MIN DIAMETER x 60" DEEP MIN, BEGINNING 8"-12" BENEATH FINISH GRADE.
- ③ 4" PERFORATED PIPE WITH APPROVED FILTER SOCK, CLEANOUT CAP, AND LOCKABLE 10" ROUND IRRIGATION BOX, HEAT STAMPED BOX "CO".
- ④ SAND TRAP (SAME BRAND AS DRINKING FOUNTAIN OR APPROVED EQUAL). LOCATE A MINIMUM OF 6" FROM EDGE OF HARDCAPE.
- ⑤ VALVE BOX, RAINBIRD OR APPROVED EQUAL. INSTALL OVER 6" GRAVEL BASE.
- ⑥ T585-70-66 MINIMUM SIZE 3/4" BALL VALVE SHUT OFF TO FOUNTAIN. INSTALL PER SPECIFICATIONS.

NOT TO SCALE

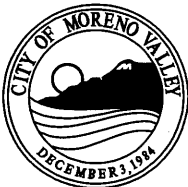

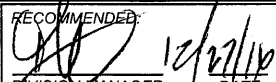
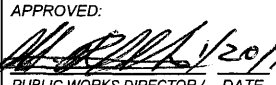
RECOMMENDED:  
  
 DIVISION MANAGER DATE  
 APPROVED:  
  
 PUBLIC WORKS DIRECTOR/ DATE  
 CITY ENGINEER

## CITY OF MORENO VALLEY

PARKS AND COMMUNITY SERVICES DEPARTMENT

### DRINKING FOUNTAIN SUMP DRAINAGE DETAIL

STANDARD PLAN

**MVGF-615A-0**

SHEET 1 OF 2

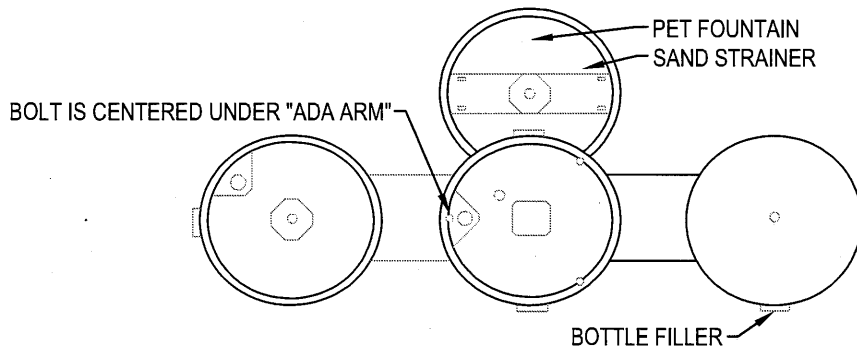
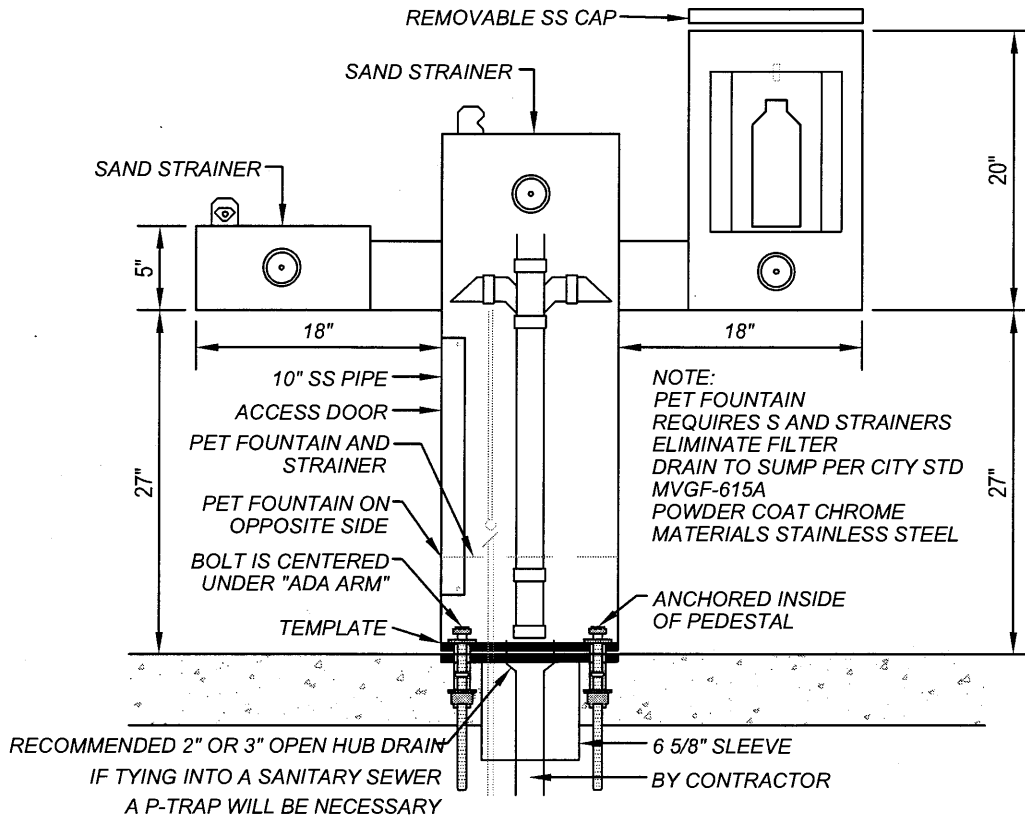

**MDF MODEL 10150 SMSS PF**

**NOTES:**

1. LOCAL, STATE, AND FEDERAL CODES SHOULD BE ADHERED TO.
2. INSTALLATION TO BE COMPLETED IN ACCORDANCE WITH MANUFACTURER'S SPECIFICATIONS.
3. CONTRACTOR'S NOTE: FOR PRODUCT AND COMPANY INFORMATION VISIT [WWW.CADDDETAILS.COM/INFO](http://WWW.CADDDETAILS.COM/INFO) AND ENTER REFERENCE NUMBER 3354-20.4.
4. MOST DEPENDABLE FOUNTAINS, INC (MDF), [WWW.MOSTDEPENDABLE.COM](http://WWW.MOSTDEPENDABLE.COM), 1-800-552-6331

NOT TO SCALE

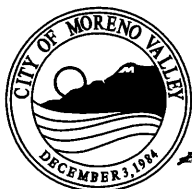

RECOMMENDED:  
*[Signature]*  
 DIVISION MANAGER DATE  
 APPROVED:  
*[Signature]* 1/20/17  
 PUBLIC WORKS DIRECTOR / DATE  
 CITY ENGINEER

**CITY OF MORENO VALLEY**

PARKS AND COMMUNITY SERVICES DEPARTMENT

**DRINKING FOUNTAIN  
 AND BOTTLE FILLER**

STANDARD PLAN

**MVGF-615B-0**

SHEET 2 OF 2

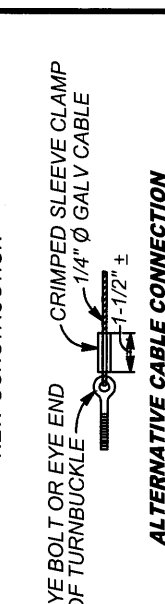
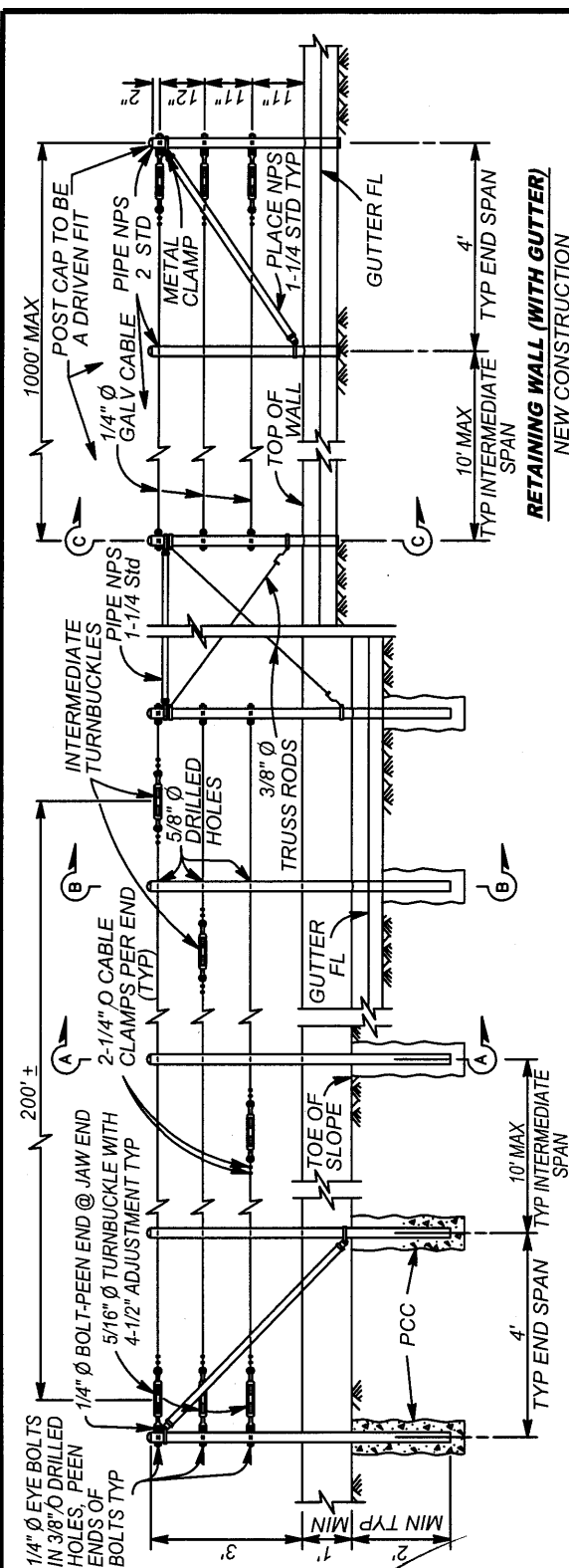

- NOTES:**
1. MAXIMUM DISTANCE BETWEEN TURNBUCKLES SHALL BE 200' ±.
  2. INTERMEDIATE TURNBUCKLES TO BE PLACED IN ADJACENT SPANS.
  3. CABLE SHALL NOT BE SPLICED BETWEEN INTERMEDIATE TURNBUCKLES AND END POSTS.
  4. ALL POSTS, CABLE, AND HARDWARE TO BE GALVANIZED.
  5. POSTS TO BE VERTICAL.
  6. ALIGNMENT OF HOLES IN POSTS MAY VARY TO CONFORM TO SLOPE OF TOP OF RETAINING WALL.
  7. THE CONTRACTOR SHALL VERIFY ALL DEPENDENT DIMENSIONS IN THE FIELD BEFORE ORDERING OR FABRICATING ANY MATERIAL. ALTERNATIVE DETAILS MAY BE SUBMITTED BY THE CONTRACTOR FOR APPROVAL BY THE ENGINEER.
  8. LINE POSTS SHALL BE BRACED HORIZONTALLY AND TRUSSED DIAGONALLY IN BOTH DIRECTIONS AT INTERVALS NOT TO EXCEED 1000'.
  9. POST POCKETS TO BE CENTERED IN TOP OF WALL.
  10. TYPICAL END SPANS, BRACED IN BOTH DIRECTIONS, SHALL BE CONSTRUCTED AT CHANGES IN LINE WHERE THE ANGLE OF DEFLECTION IS 15° OR MORE.
  11. PROVIDE THIMBLES AT ALL CABLE LOOPS.
  12. APPLY STRUCTURAL EPOXY TO EYE AND TURNBUCKLE THREAD ENDS.

**RETAINING WALL (WITH GUTTER) EXISTING**

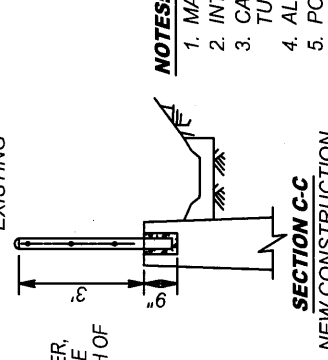

**EXISTING WALL (WITHOUT GUTTER) EXISTING**

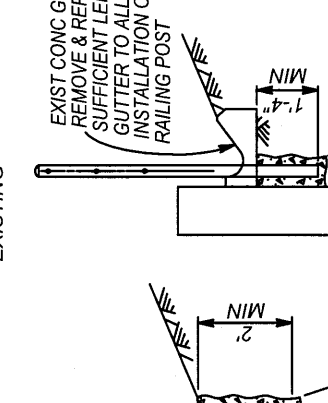

**SECTION C-C NEW CONSTRUCTION**

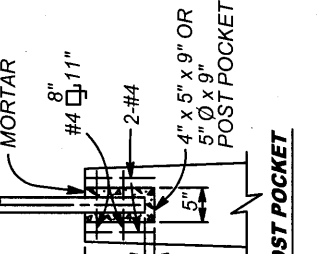

**SECTION B-B EXISTING**

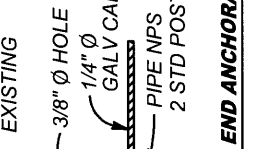

NOT TO SCALE

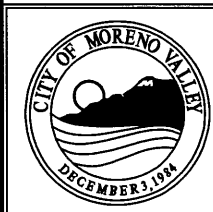

RECOMMENDED:  
*[Signature]*  
 DIVISION MANAGER DATE 11/21/16  
 APPROVED:  
*[Signature]*  
 PUBLIC WORKS DIRECTOR / DATE 12/01/17  
 CITY ENGINEER

**CITY OF MORENO VALLEY**

PARKS AND COMMUNITY SERVICES DEPARTMENT

**CABLE RAILING**

STANDARD PLAN



**MVGF-616-0**

SHEET 1 OF 1

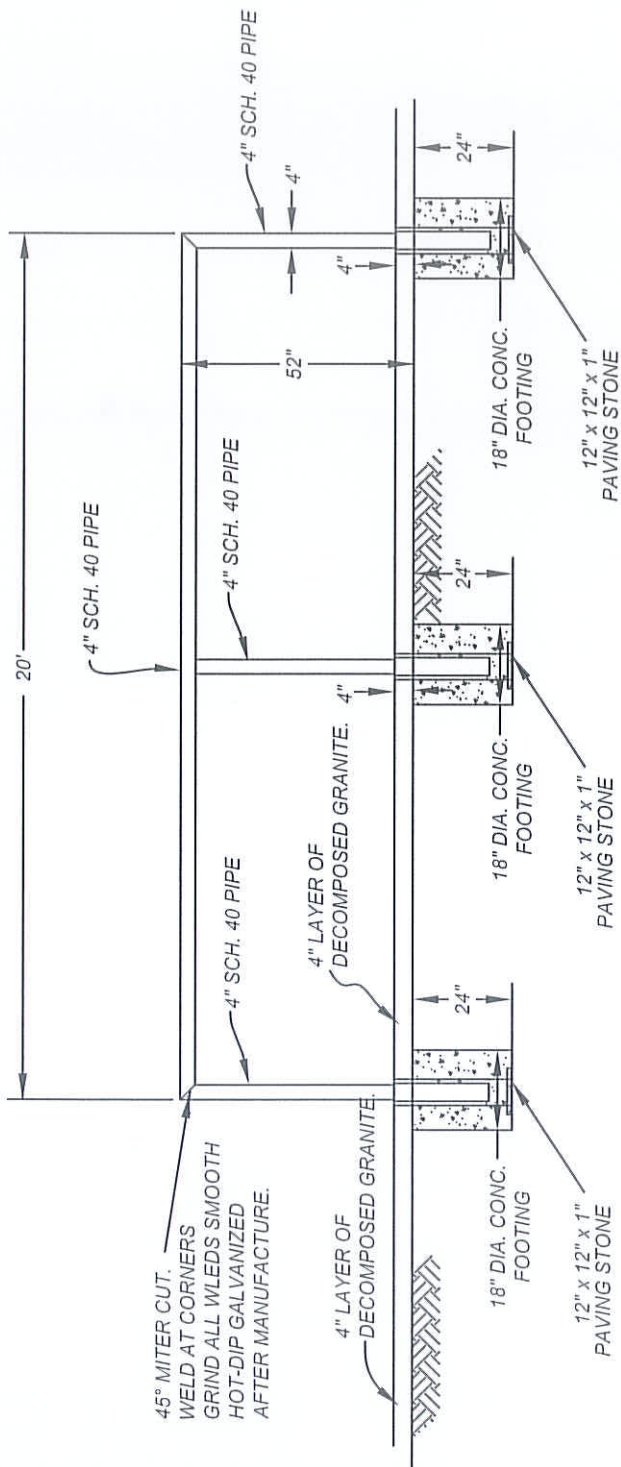

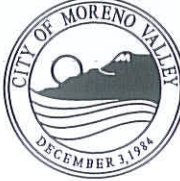

NOT TO SCALE

	RECOMMENDED:  1/29/14 DIVISION MANAGER DATE	<b>CITY OF MORENO VALLEY</b> PARKS AND COMMUNITY SERVICES DEPARTMENT	
	APPROVED:  1/29/14 PUBLIC WORKS DIRECTOR / DATE CITY ENGINEER		
			SHEET 1 OF 1

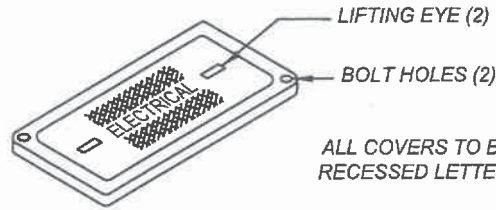

ALL COVERS TO BE IDENTIFIED WITH RECESSED LETTERS.

**TYPICAL COVER**  
COMPOSITE WITH POLYPROPYLENE

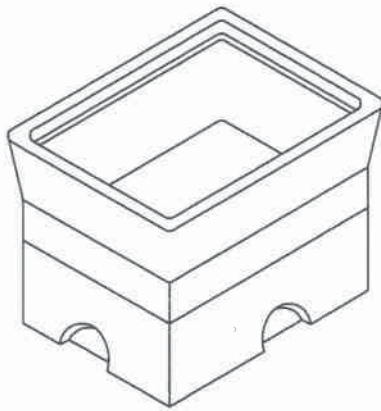

**TYPICAL ASSEMBLY WITHOUT COVER**  
(CONCRETE)

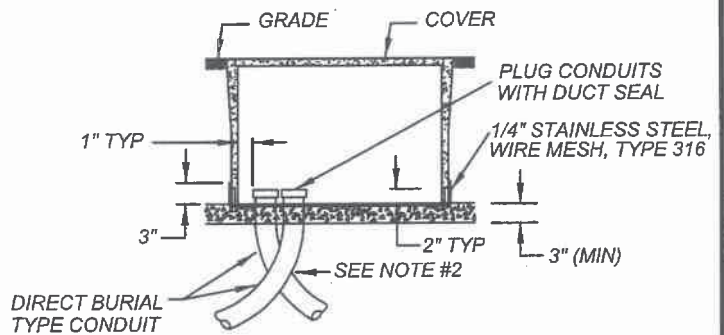

**SECTION A-A**

**ALL CONDUITS**

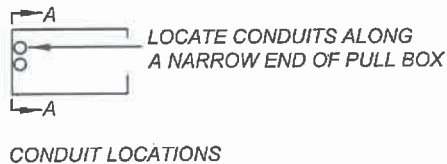

**NOTES:**

- 1.) RADIUS ANGLE MAY BE REDUCED TO LESS THAN 90° PROVIDING THE PROJECTED CENTER LINE OF THE CONDUIT CLEARS HANDHOLE OPENING.
- 2.) TWO HOLD DOWN DEVICES TO BE SUPPLIED WITH EACH HANDHOLE.
- 3.) ELECTRICAL CONDUITS SHALL BE TAPE WRAPPED SCH. 40 GALVANIZED CONDUIT.

NOT TO SCALE



RECOMMENDED:  
*[Signature]* 6/20/19  
DIVISION MANAGER DATE  
APPROVED:  
*[Signature]* 7/30/19  
PUBLIC WORKS DIRECTOR / DATE  
CITY ENGINEER

**CITY OF MORENO VALLEY**  
PARKS AND COMMUNITY SERVICES DEPARTMENT

**ELECTRICAL PULL BOX  
FOR PARKS**

STANDARD PLAN  
**MVGF-618A-0**  
SHEET 1 OF 2

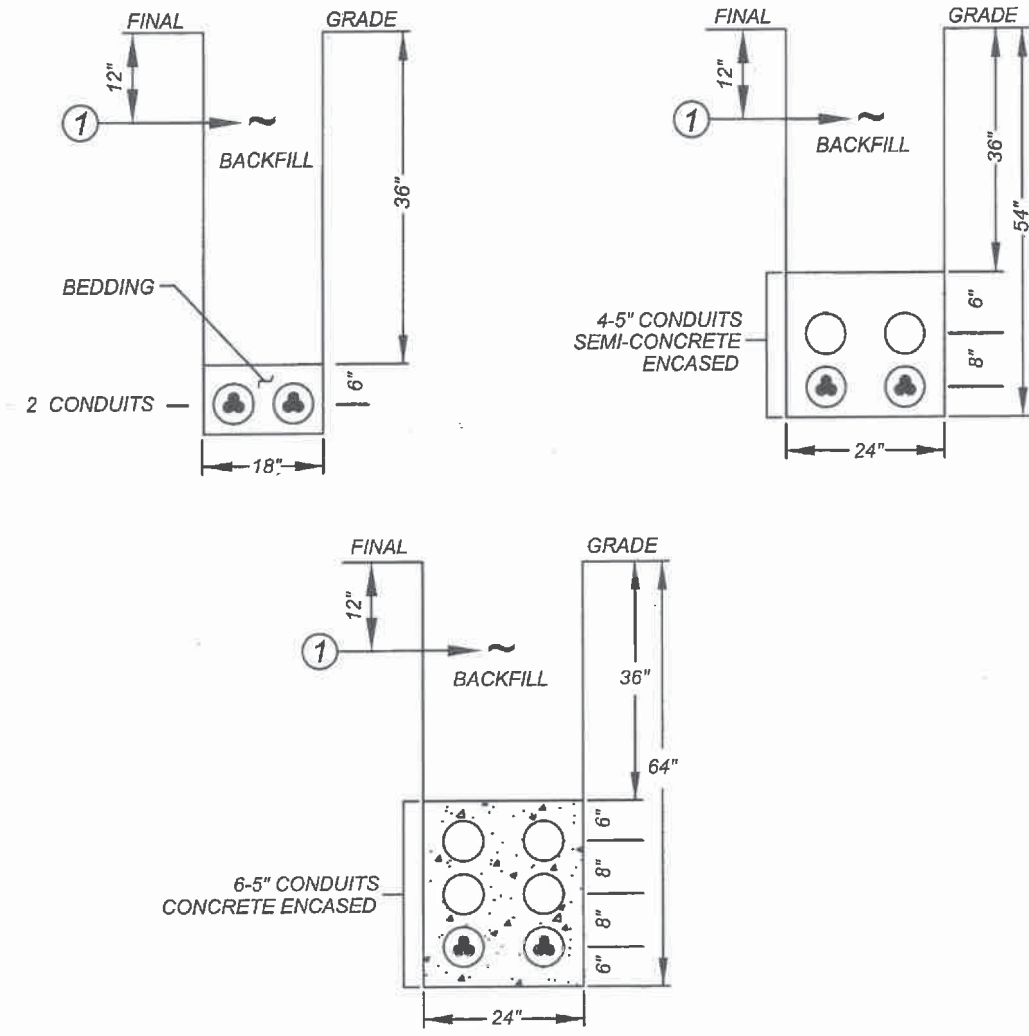

① DETECTABLE WARNING TAPE

**NOTES:**

- 1.) BEDDING MATERIAL SHALL BE CLEAN SAND OR PEA GRAVEL. OTHERWISE, NATIVE MATERIALS MAY BE USED PROVIDED THEY MEET PUBLIC WORKS CONSTRUCTION (GREEN BOOK) STANDARDS PER SUBSECTION 306.1.2.1 AND MUST HAVE A SAND EQUIVALENT OF NOT LESS THAN 30 OR HAVING A COEFFICIENT OF PERMEABILITY GREATER THAN 1.4 INCHES/HR.
- 2.) CONDUITS ARE DB, EB, OR SCH 40 DEPENDING ON APPLICATION PER PLAN.
- 3.) CONCRETE SHALL BE ONE SACK ENCASEMENT.

NOT TO SCALE

	RECOMMENDED:  DIVISION MANAGER      DATE	<h2 style="margin: 0;">CITY OF MORENO VALLEY</h2> <p style="margin: 0;">PARKS AND COMMUNITY SERVICES DEPARTMENT</p>	STANDARD PLAN <b>MVGF-618B-0</b>
	APPROVED:  PUBLIC WORKS DIRECTOR / DATE CITY ENGINEER	<h3 style="margin: 0;">TRENCH DETAILS FOR CONDUIT INSTALLATIONS IN PARKS</h3>	

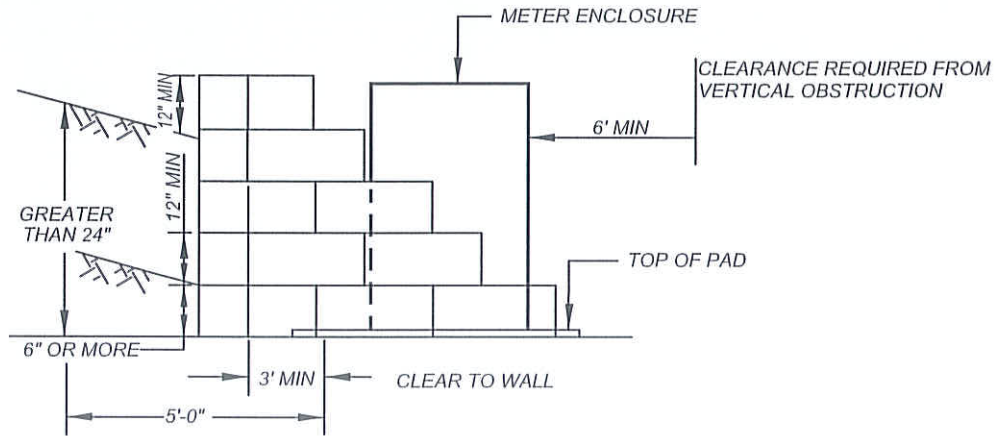
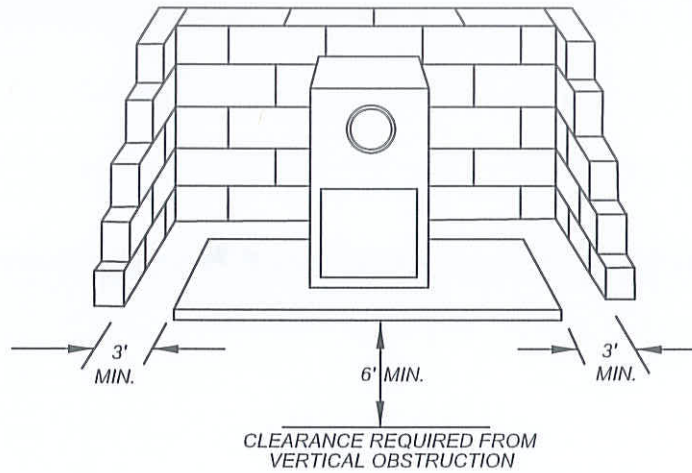

**NOTES:**

1. RETAINING WALLS ARE REQUIRED WHERE A SLOPING GRADE RISES 24" OR MORE AT A HORIZONTAL DISTANCE OF 5' OR LESS FROM THE EDGE OF PAD OR ENCLOSURE.
2. RETAINING WALLS ARE ALSO REQUIRED WHENEVER THE GRADE RISES 6" ABOVE THE TOP OF PAD (SEE DRAWING DETAILS).
3. RETAINING WALLS MUST BE APPROVED BY BUILDING DEPARTMENT AND REQUIRES A SEPARATE PERMITS.
4. RETAINING WALLS MUST BE SEALED.

NOT TO SCALE

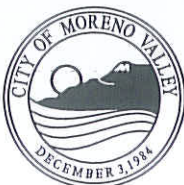

RECOMMENDED:  
 [Signature] 1/21/14  
 DIVISION MANAGER DATE  
 APPROVED:  
 [Signature] 1/29/14  
 PUBLIC WORKS DIRECTOR / DATE  
 CITY ENGINEER

**CITY OF MORENO VALLEY**

PARKS AND COMMUNITY SERVICES DEPARTMENT

**RETAINING WALLS FOR  
 PAD-MOUNTED  
 METER ENCLOSURES**

STANDARD PLAN  
**MVGF-619-0**

SHEET 1 OF 1



\*APPROX. WT: 3,066 LBS. (SIGN PANEL)  
 \*APPROX. WT: 1,248 LBS. (SIGN BASE)

CAST-IN LETTERS  
 FONT: AMERICANA  
 HEIGHT: 6"  
 INSET: 1/2" DEEP  
 PAINTED: BLACK  
 (CENTERED)

CAST-IN LETTERS  
 FONT: AMERICANA  
 HEIGHT: 4"  
 INSET: 1/4" DEEP  
 PAINTED: BLACK  
 (CENTERED)

- \* ALL EDGES TO HAVE 1/4" RADIUS MIN.
- \* MANUFACTURING TOLERANCE ±1/4".
- \* PRODUCT: TWO SIDED SIGN (96" L. x 60" HT.)
- \* QUANTITY: \_\_\_\_\_
- \* CONCRETE COLOR: MIX#5241 (OMAHA TAN)
- \* CONCRETE TEXTURE: SEE BELOW
- \* SEALER: NONE
- \* MFG: QUICKCRETE PRODUCTS
- \* ANTIGRAFFITI COATING PER PARKS & COMM. SPECS.

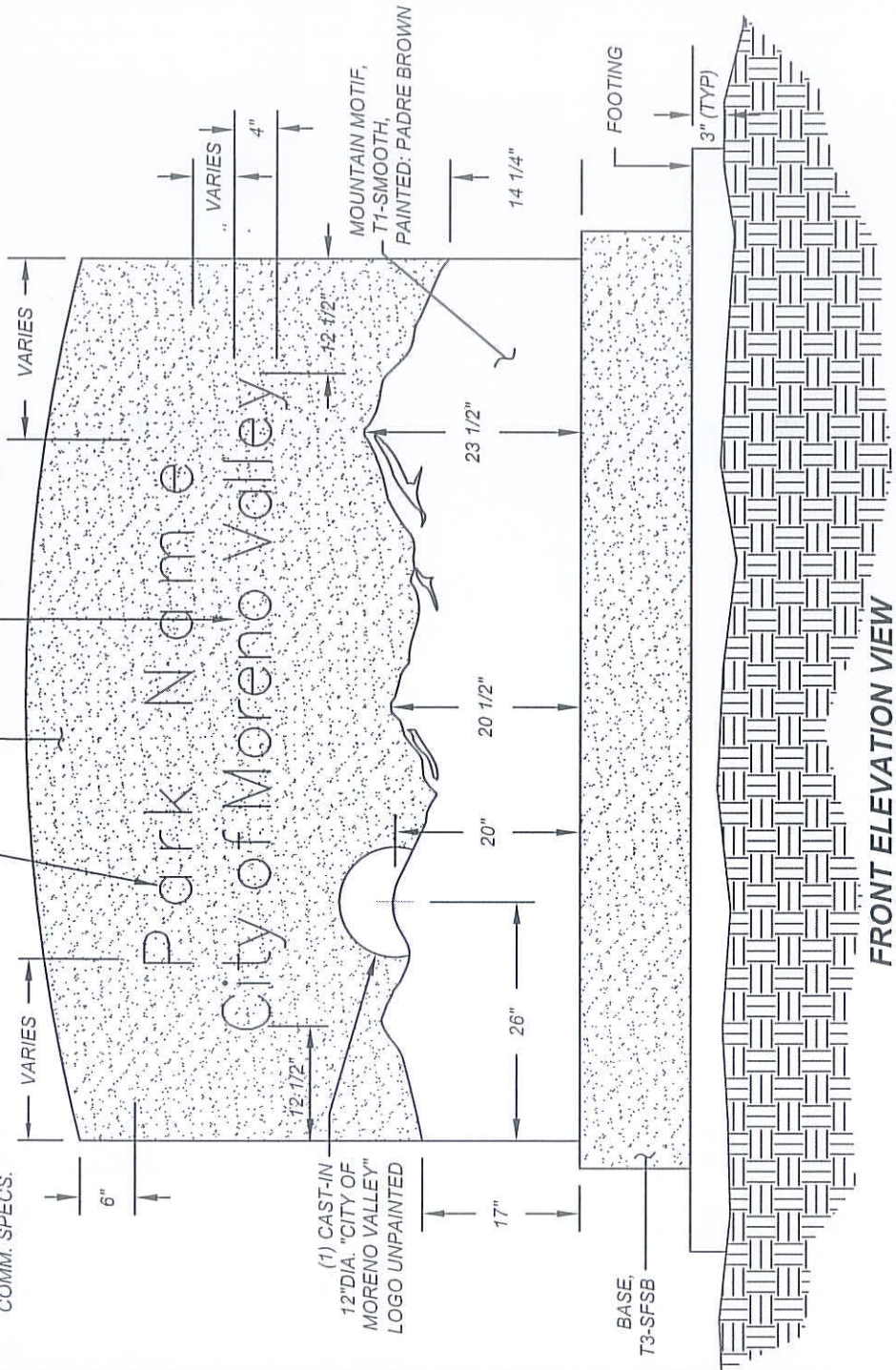

FRONT ELEVATION VIEW

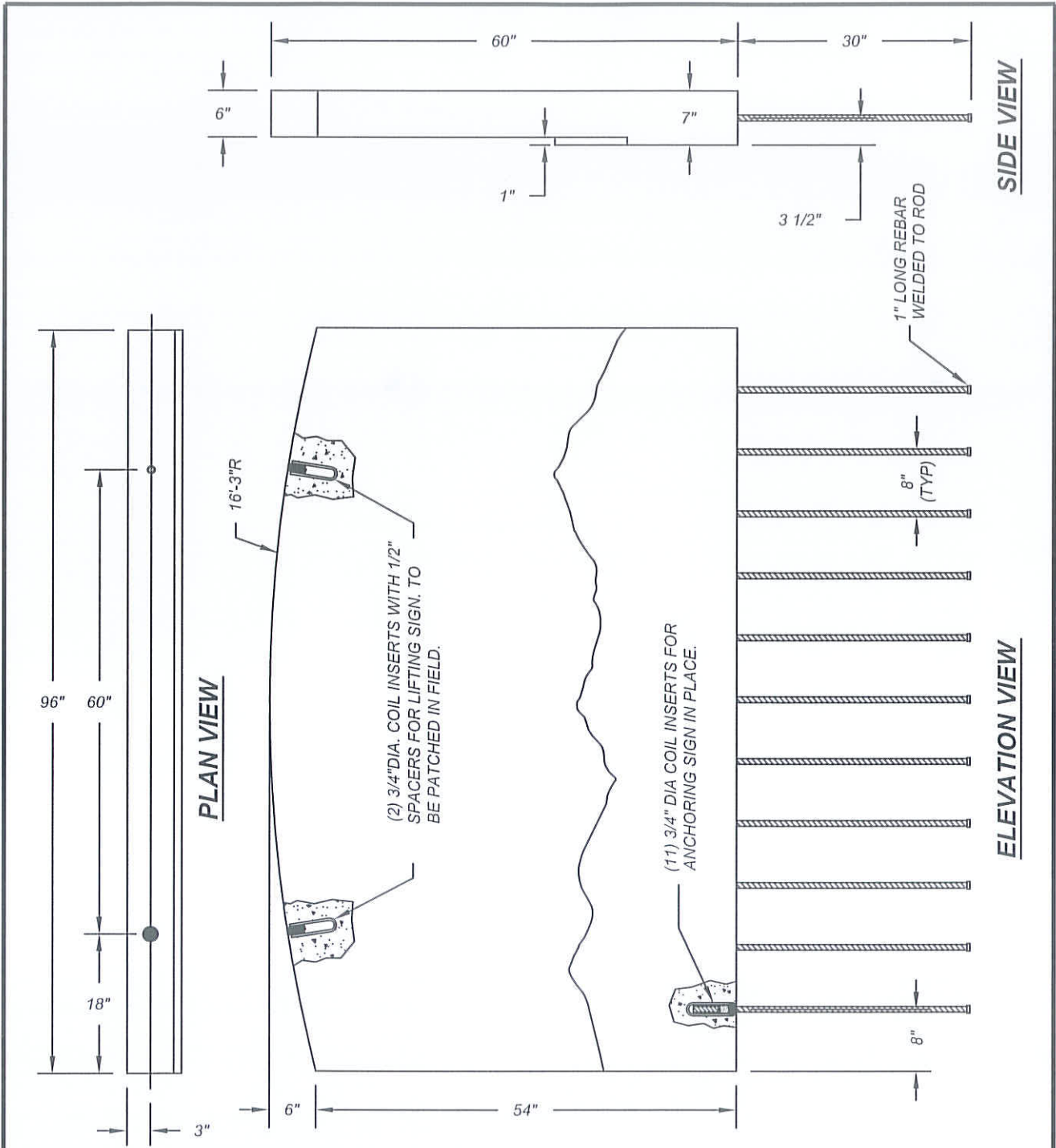

**NOTE:** THIS STANDARD PLAN WAS REVIEWED AND APPROVED BY THE COMMUNITY DEVELOPMENT DEPARTMENT, PLANNING AND BUILDING AND SAFETY DIVISIONS, ON 11-02-2009. COPY OF THE STAMP APPROVED STANDARD IS ON FILE WITH THE CAPITAL PROJECTS DIVISION. NOT TO SCALE

	RECOMMENDED:  DIVISION MANAGER      11/21/14 DATE	<b>CITY OF MORENO VALLEY</b> PARKS AND COMMUNITY SERVICES DEPARTMENT	STANDARD PLAN
	APPROVED:  PUBLIC WORKS DIRECTOR / DATE CITY ENGINEER      1/29/14	<b>GRAPHIC PLAN</b> <b>TWO SIDED SIGN (96" L. x 60" HT.)</b>	<b>MVGF-620A-0</b>



**NOTE:** THIS STANDARD PLAN WAS REVIEWED AND APPROVED BY THE COMMUNITY DEVELOPMENT DEPARTMENT, PLANNING AND BUILDING AND SAFETY DIVISIONS, ON 11-02-2009. COPY OF THE STAMP APPROVED STANDARD IS ON FILE WITH THE CAPITAL PROJECTS DIVISION.

NOT TO SCALE

	RECOMMENDED:  1/21/14 DIVISION MANAGER DATE	<b>CITY OF MORENO VALLEY</b> PARKS AND COMMUNITY SERVICES DEPARTMENT	STANDARD PLAN <b>MVGF-620B-0</b>
	APPROVED:  1/29/14 PUBLIC WORKS DIRECTOR / DATE CITY ENGINEER		



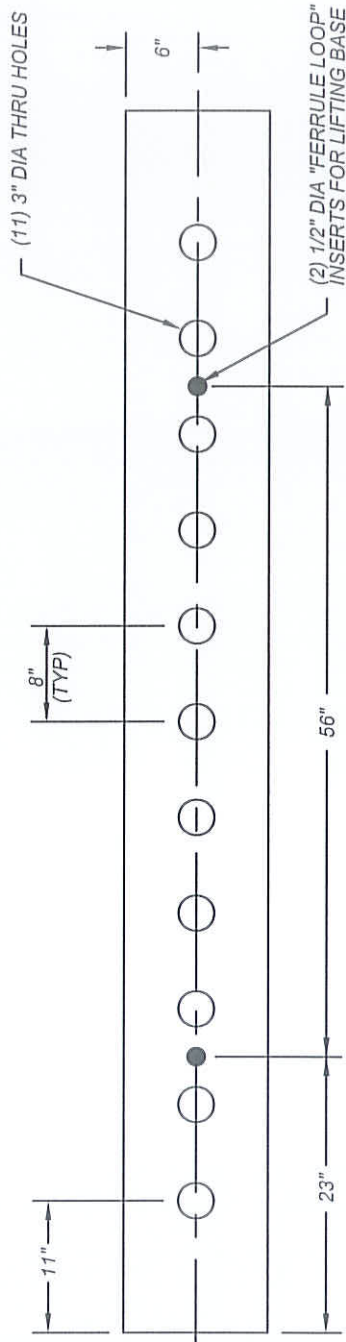

PLAN VIEW

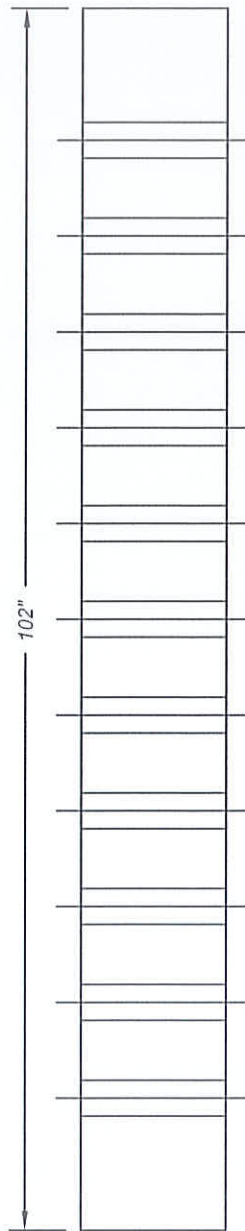

ELEVATION VIEW

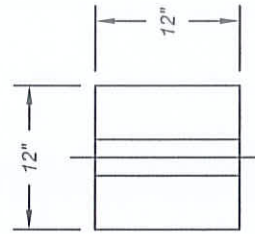

SIDE VIEW

**NOTE:** THIS STANDARD PLAN WAS REVIEWED AND APPROVED BY THE COMMUNITY DEVELOPMENT DEPARTMENT, PLANNING AND BUILDING AND SAFETY DIVISIONS, ON 11-02-2009. COPY OF THE STAMP APPROVED STANDARD IS ON FILE WITH THE CAPITAL PROJECTS DIVISION.

NOT TO SCALE

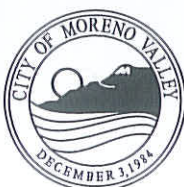

RECOMMENDED:  
  
 DIVISION MANAGER DATE 11/31/14  
 APPROVED:  
  
 PUBLIC WORKS DIRECTOR / DATE 1/29/14  
 CITY ENGINEER

# CITY OF MORENO VALLEY

PARKS AND COMMUNITY SERVICES DEPARTMENT

**CONSTRUCTION PLAN**  
**SIGN BASE (12" W. x 102" L.)**

STANDARD PLAN  
**MVGF-620C-0**

SHEET 3 OF 4

**INSTALLATION NOTES:**

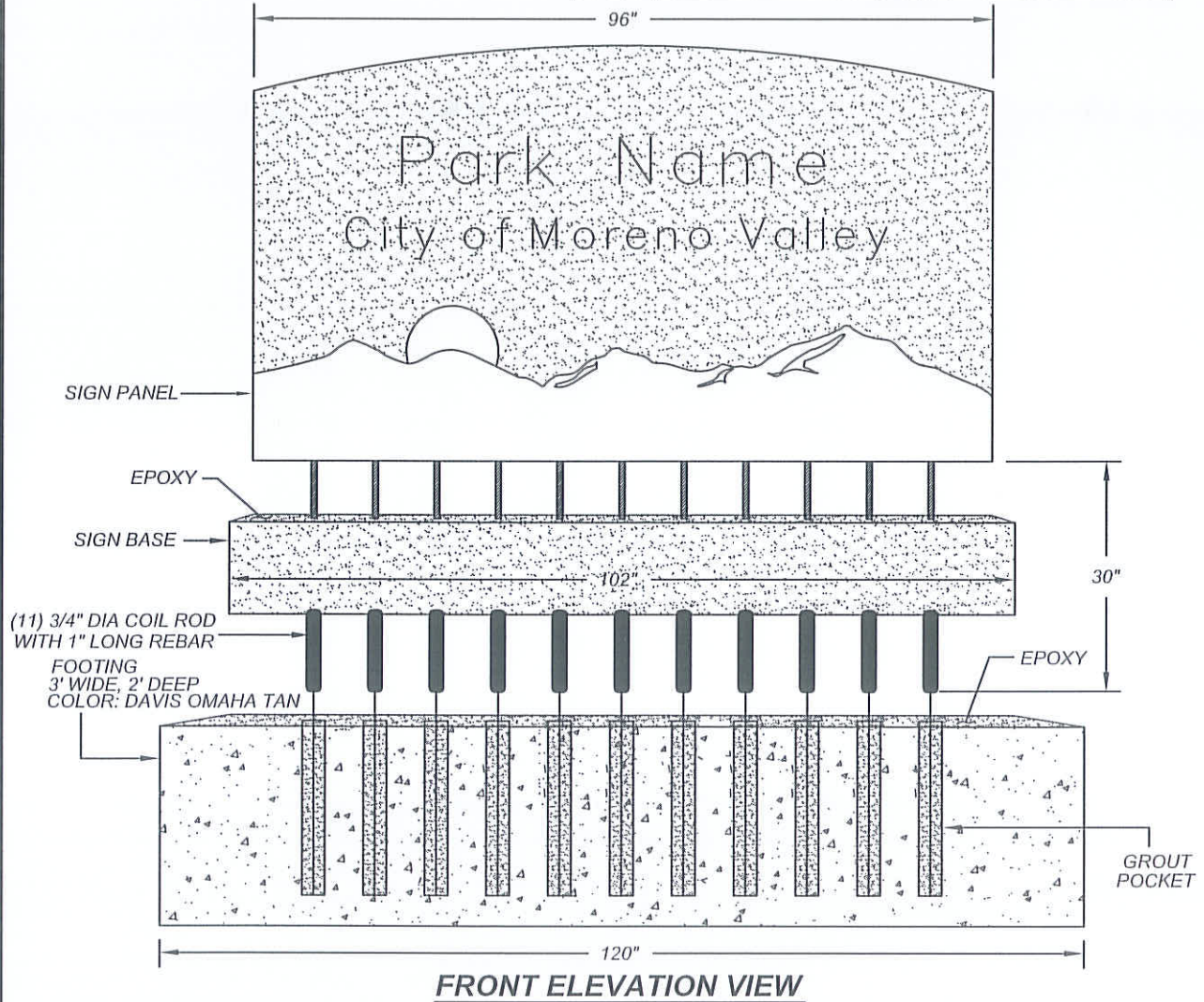

1. CAST-IN OR CORE DRILL (11) 3" DIA x 20" DEEP GROUT POCKETS INTO FOOTING PER ANCHOR BOLT PATTERN (SEE PLAN BELOW).
2. POUR ESR-2508 RATED EPOXY ON THE FOOTING WHERE BASE WILL BE PLACED.
3. SET BASE ALIGNING HOLES WITH GROUT POCKETS.
4. TAKE (11) 3/4"DIA x 35" LONG COIL RODS AND THREAD 5" INTO (11) 3/4" DIA COIL INSERTS, LEAVING 30" OF COIL ROD EXPOSED.
5. FILL ALL GROUT POCKETS WITH NON-SHRINK GROUT AND POUR EPOXY ON THE BASE WHERE SIGN WILL BE PLACED. INSERT SIGN WITH COIL RODS THROUGH BASE INTO GROUT POCKETS. GROUT TO COMPLY W/ ASTM C-827, ASTM C-1090, ASTM C-1107.
6. FOOTING REINFORCEMENT: #4 REBAR @ 12" O.C. ALL DIRECTIONS. TIE WITH 1/32" (0.8 MM) ANNEALED STEEL WIRE.
7. REQUIRES SPECIAL INSPECTION.

HARDWARE LIST	
QTY	TYPE
11	3/4" DIA x 35" LONG COIL ROD WITH 1" LONG REBAR
1	PATCH KIT

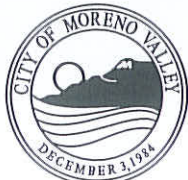

**FRONT ELEVATION VIEW**

**NOTE:** THIS STANDARD PLAN WAS REVIEWED AND APPROVED BY THE COMMUNITY DEVELOPMENT DEPARTMENT, PLANNING AND BUILDING AND SAFETY DIVISIONS, ON 11-02-2009. COPY OF THE STAMP APPROVED STANDARD IS ON FILE WITH THE CAPITAL PROJECTS DIVISION. NOT TO SCALE

	RECOMMENDED:  DIVISION MANAGER DATE: 11/21/14	<b>CITY OF MORENO VALLEY</b> PARKS AND COMMUNITY SERVICES DEPARTMENT	
	APPROVED:  PUBLIC WORKS DIRECTOR / CITY ENGINEER DATE: 1/29/14	<b>INSTALLATION PLAN</b> <b>TWO SIDED SIGN (96" L. X 60" H.)</b>	



\*APPROX. WT: 3,066 LBS. (SIGN PANEL)  
 \*APPROX. WT: 1,248 LBS. (SIGN BASE)

CAST-IN LETTERS  
 FONT: AMERICANA  
 HEIGHT: 6"  
 INSET: 1/2" DEEP  
 PAINTED: BLACK  
 (CENTERED)

CAST-IN LETTERS  
 FONT: AMERICANA  
 HEIGHT: 4"  
 INSET: 1/4" DEEP  
 PAINTED: BLACK  
 (CENTERED)

- \* ALL EDGES TO HAVE 1/4" RADIUS MIN.
- \* MANUFACTURING TOLERANCE ±1/4".
- \* PRODUCT: ONE SIDED SIGN (96"L. x 60"HT.)
- \* QUANTITY: \_\_\_\_\_
- \* CONCRETE COLOR: MIX#5241 (OMAHA TAN)
- \* CONCRETE TEXTURE: SEE BELOW
- \* SEALER: NONE
- \* MFG: QUICKCRETE PRODUCTS
- \* ANTIGRAFFITI COATING PER PARKS & COMM. SPECS.

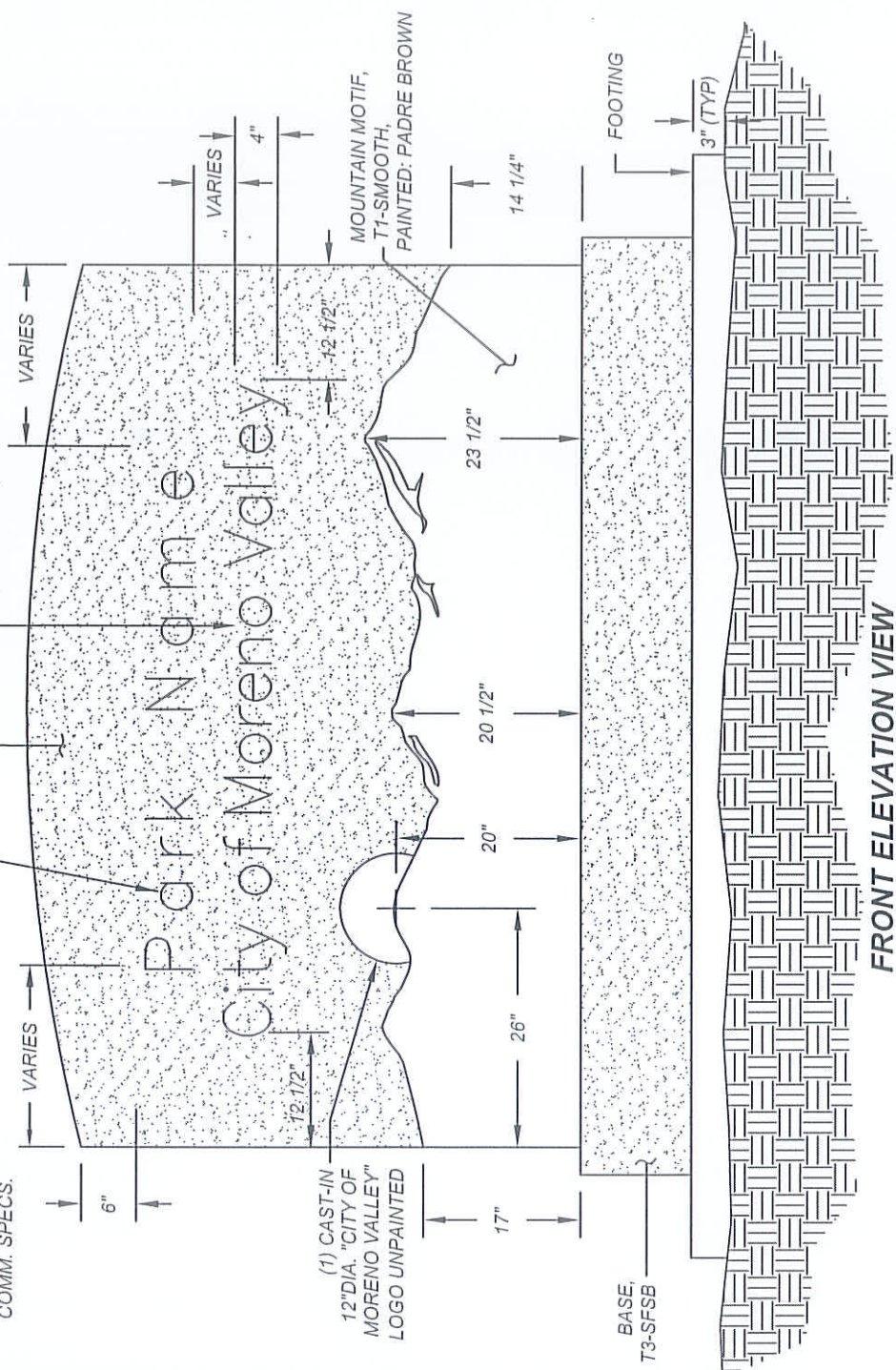

FRONT ELEVATION VIEW

**NOTE:** THIS STANDARD PLAN WAS REVIEWED AND APPROVED BY THE COMMUNITY DEVELOPMENT DEPARTMENT, PLANNING AND BUILDING AND SAFETY DIVISIONS, ON 11-02-2009. COPY OF THE STAMP APPROVED STANDARD IS ON FILE WITH THE CAPITAL PROJECTS DIVISION. NOT TO SCALE



RECOMMENDED:  
*[Signature]* 1/21/14  
 DIVISION MANAGER DATE

APPROVED:  
*[Signature]* 1/29/14  
 PUBLIC WORKS DIRECTOR / DATE  
 CITY ENGINEER

<h2 style="margin: 0;">CITY OF MORENO VALLEY</h2> <p style="margin: 0;">PARKS AND COMMUNITY SERVICES DEPARTMENT</p>	
<p style="margin: 0;"><b>GRAPHIC PLAN</b></p> <p style="margin: 0;"><b>ONE SIDED SIGN (96" L. X 60" HT.)</b></p>	<p style="margin: 0;">STANDARD PLAN</p> <p style="margin: 0;"><b>MVGF-621A-0</b></p> <p style="margin: 0;">SHEET 1 OF 4</p>

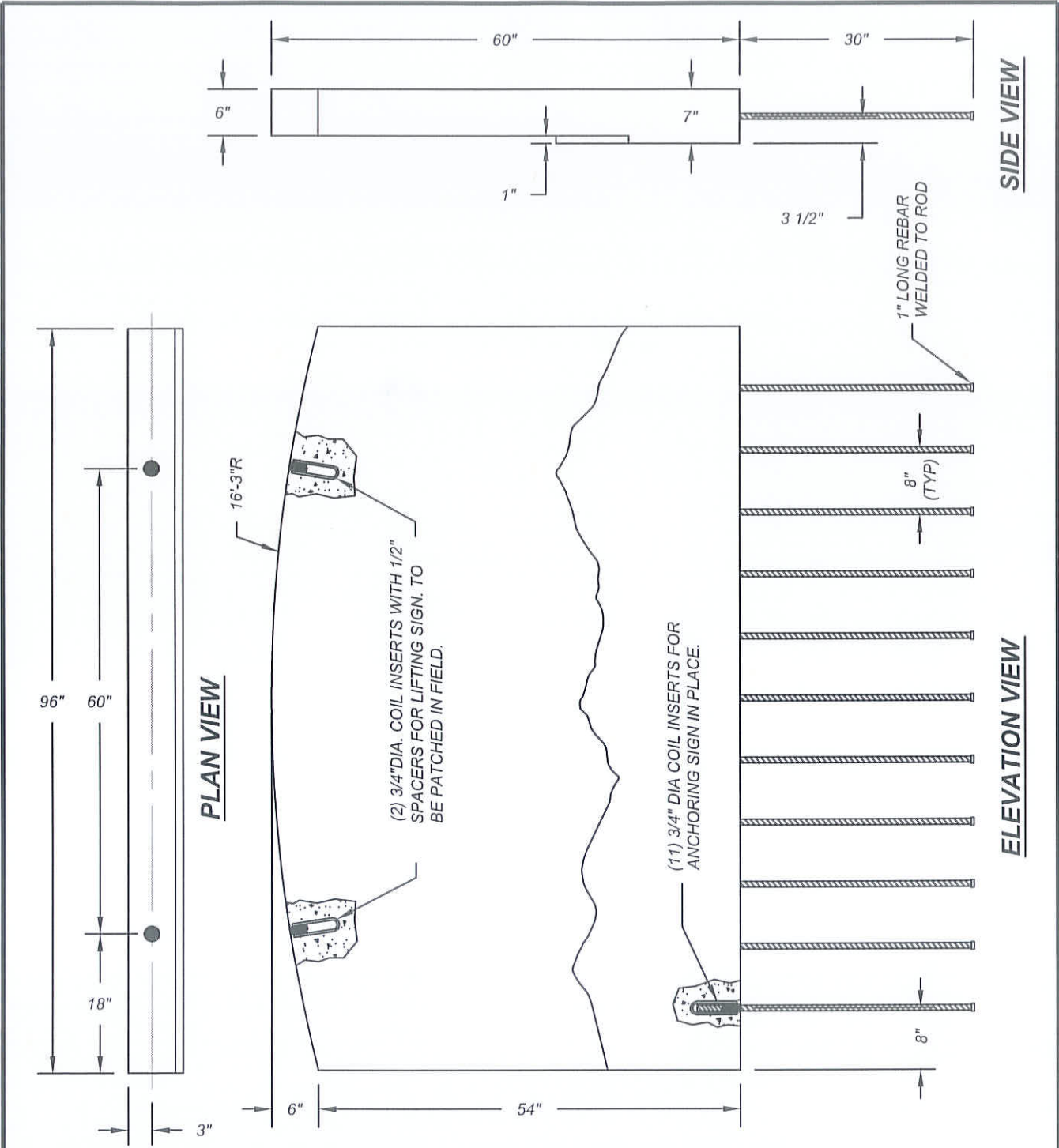

**NOTE:** THIS STANDARD PLAN WAS REVIEWED AND APPROVED BY THE COMMUNITY DEVELOPMENT DEPARTMENT, PLANNING AND BUILDING AND SAFETY DIVISIONS, ON 11-02-2009. COPY OF THE STAMP APPROVED STANDARD IS ON FILE WITH THE CAPITAL PROJECTS DIVISION.

NOT TO SCALE

	RECOMMENDED:  1/21/14 DIVISION MANAGER DATE	<b>CITY OF MORENO VALLEY</b> PARKS AND COMMUNITY SERVICES DEPARTMENT	
	APPROVED:  1/29/14 PUBLIC WORKS DIRECTOR / DATE / CITY ENGINEER	<b>CONSTRUCTION PLAN</b> <b>ONE SIDED SIGN</b> <b>(96" L. X 60" HT.)</b>	



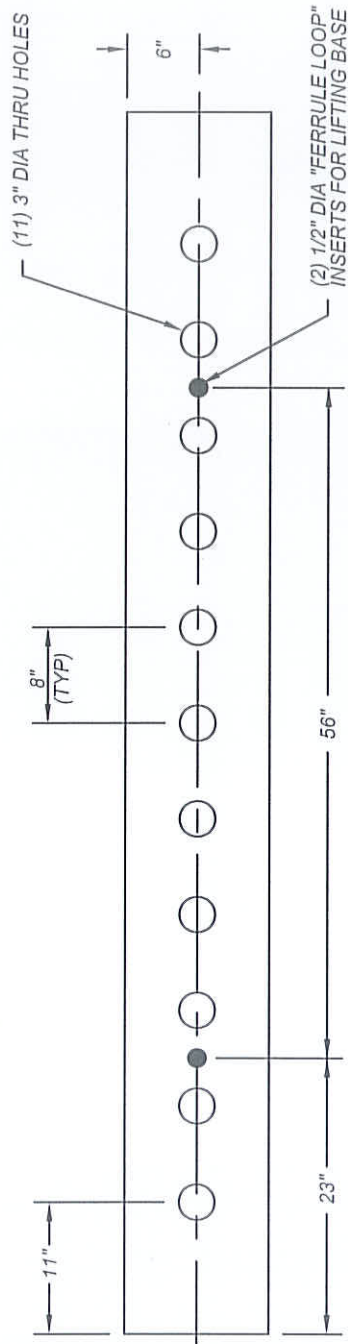

PLAN VIEW

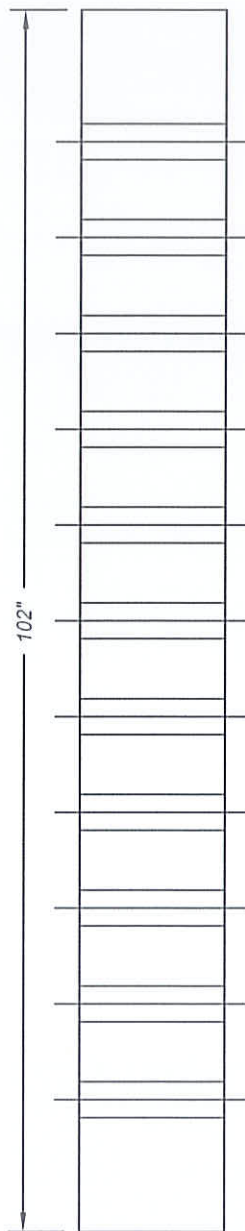

ELEVATION VIEW

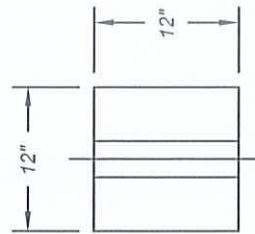

SIDE VIEW

**NOTE:** THIS STANDARD PLAN WAS REVIEWED AND APPROVED BY THE COMMUNITY DEVELOPMENT DEPARTMENT, PLANNING AND BUILDING AND SAFETY DIVISIONS, ON 11-02-2009. COPY OF THE STAMP APPROVED STANDARD IS ON FILE WITH THE CAPITAL PROJECTS DIVISION.

NOT TO SCALE

	RECOMMENDED:  DIVISION MANAGER DATE 1/21/14	<b>CITY OF MORENO VALLEY</b> PARKS AND COMMUNITY SERVICES DEPARTMENT	
	APPROVED:  PUBLIC WORKS DIRECTOR / CITY ENGINEER DATE 1/29/14	<b>CONSTRUCTION PLAN</b> <b>SIGN BASE (12"W. X 102"L.)</b>	
			SHEET 3 OF 4

**INSTALLATION NOTES:**

1. CAST-IN OR CORE DRILL (11) 3/4" DIA x 20" DEEP GROUT POCKETS INTO FOOTING PER ANCHOR BOLT PATTERN (SEE PLAN BELOW).
2. POUR ESR-2508 RATED EPOXY ON THE FOOTING WHERE BASE WILL BE PLACED.
3. SET BASE ALIGNING HOLES WITH GROUT POCKETS.
4. TAKE (11) 3/4"DIA x 35" LONG COIL RODS AND THREAD 5" INTO (11) 3/4" DIA COIL INSERTS, LEAVING 30" OF COIL ROD EXPOSED.
5. FILL ALL GROUT POCKETS WITH NON-SHRINK GROUT AND POUR EPOXY ON THE BASE WHERE SIGN WILL BE PLACED. INSERT SIGN WITH COIL RODS THROUGH BASE INTO GROUT POCKETS. GROUT TO COMPLY W/ ASTM C-827, ASTM C-1090, ASTM C-1107.
6. FOOTING REINFORCEMENT: #4 REBAR @ 12" O.C. ALL DIRECTIONS. TIE WITH 1/32" (0.8 MM) ANNEALED STEEL WIRE.
7. REQUIRES SPECIAL INSPECTION.

HARDWARE LIST	
QTY	TYPE
11	3/4" DIA x 35" LONG COIL ROD WITH 1" LONG REBAR
1	PATCH KIT

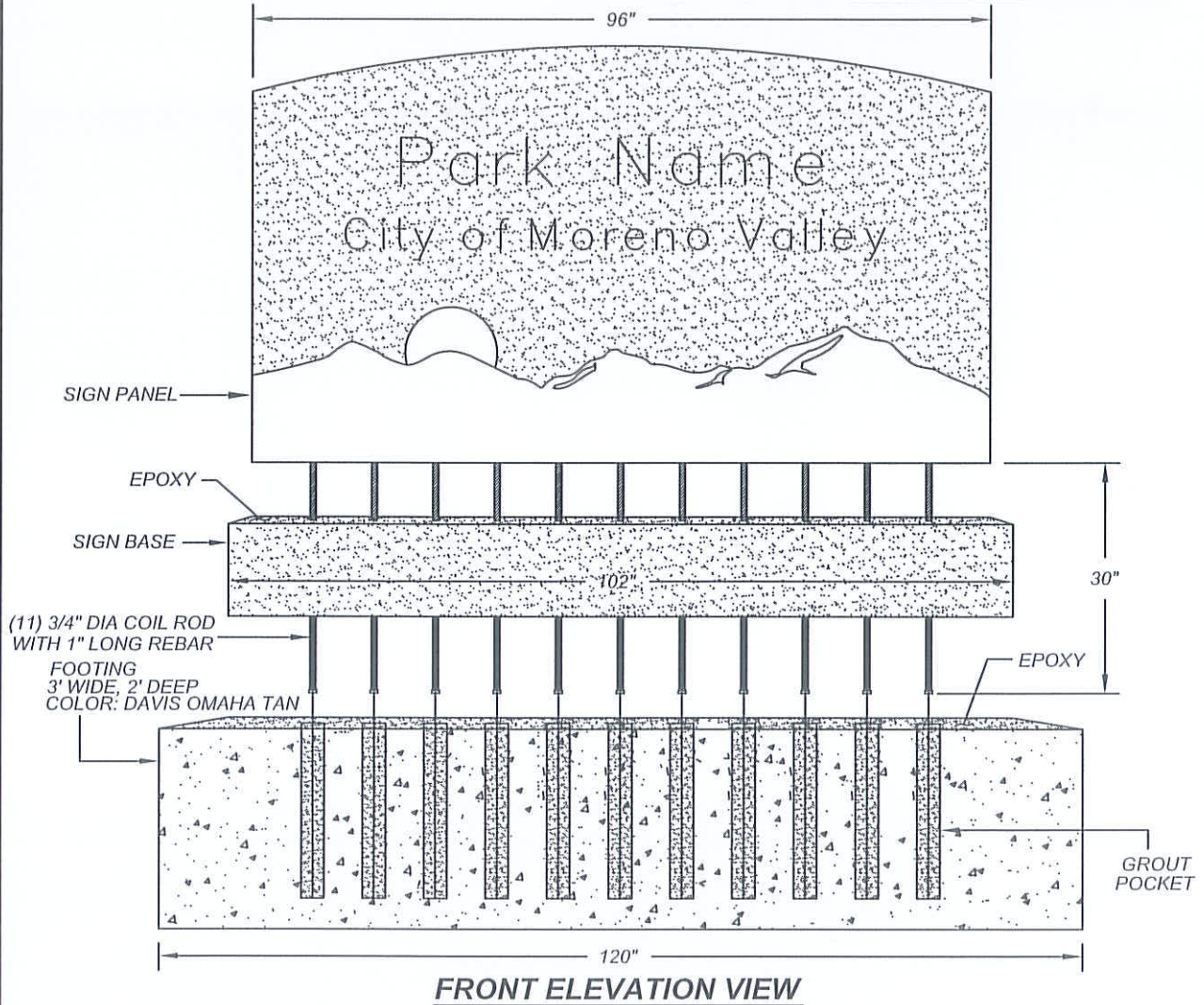

**FRONT ELEVATION VIEW**

**NOTE:** THIS STANDARD PLAN WAS REVIEWED AND APPROVED BY THE COMMUNITY DEVELOPMENT DEPARTMENT, PLANNING AND BUILDING AND SAFETY DIVISIONS, ON 11-02-2009. COPY OF THE STAMP APPROVED STANDARD IS ON FILE WITH THE CAPITAL PROJECTS DIVISION.

NOT TO SCALE

	RECOMMENDED:  1/21/14 DIVISION MANAGER DATE	<b>CITY OF MORENO VALLEY</b> PARKS AND COMMUNITY SERVICES DEPARTMENT	
	APPROVED:  1/29/14 PUBLIC WORKS DIRECTOR / DATE CITY ENGINEER	<b>INSTALLATION PLAN</b> <b>ONE SIDED SIGN (96"L. X 60"H.)</b>	
			SHEET 4 OF 4



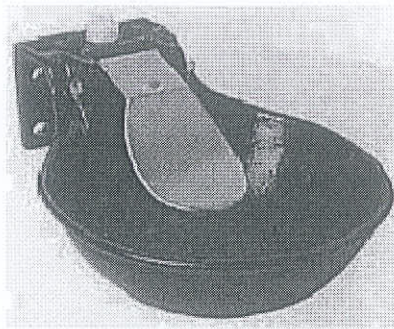

PUSH PADDLE WATERING BOWL:  
STAINLESS STEEL OR CAST IRON  
CONSTRUCTION

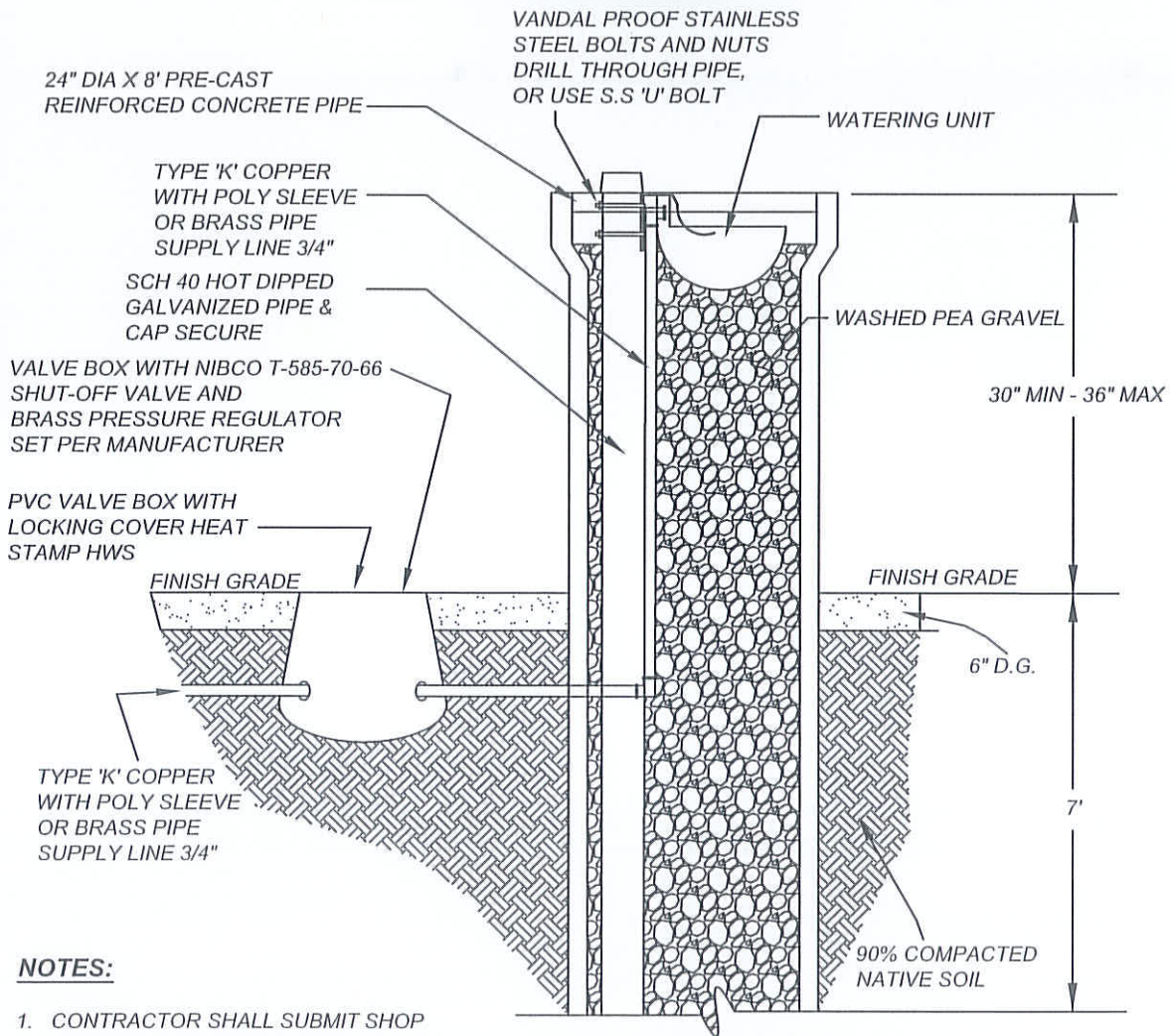

**HORSE WATERING STATION**

NOT TO SCALE

**NOTES:**

1. CONTRACTOR SHALL SUBMIT SHOP DRAWINGS FOR APPROVAL BY PARKS & COMMUNITY SERVICES.
2. REQUIRES SEPARATE BACKFLOW DEVICE

	RECOMMENDED:  DIVISION MANAGER DATE: 1/21/14	<h2 style="margin: 0;">CITY OF MORENO VALLEY</h2> <p style="margin: 0;">PARKS AND COMMUNITY SERVICES DEPARTMENT</p>
	APPROVED:  PUBLIC WORKS DIRECTOR / CITY ENGINEER DATE: 1/29/14	<h3 style="margin: 0;">HORSE WATERING STATION</h3>
SHEET 1 OF 1		

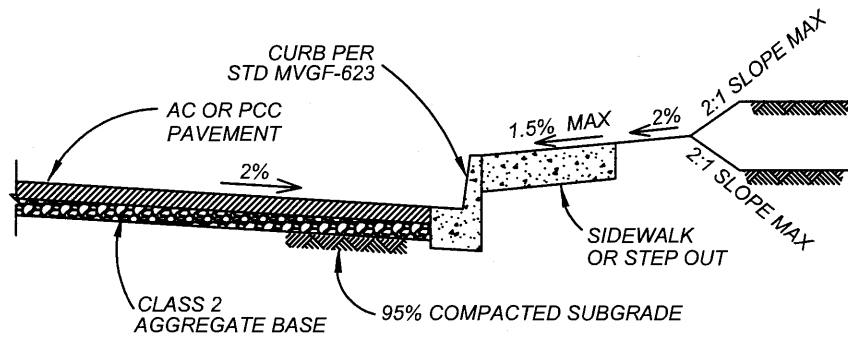

TYPICAL SECTION

**NOTES:**

- 1.) MINIMUM THICKNESS OF PAVEMENT SECTION SHALL BE 0.50' AC/1.0' CLASS 2 AB IN DRIVE ISLES AND BUS PARKING, AND 0.33' AC/0.50' CLASS 2 AB FOR PASSENGER VEHICLES.
- 2.) AC SHALL BE PLACED IN LIFTS, AND THICKNESS OF EACH LIFT SHALL NOT EXCEED 3".
- 3.) MINIMUM T.I. = 10 FOR DRIVE ISLES AND BUS PARKING  
MINIMUM T.I. = 7 FOR PASSENGER VEHICLES
- 4.) CONCRETE SHALL BE CLASS 650-CW-4000 OR 660-CW-4000

NOT TO SCALE

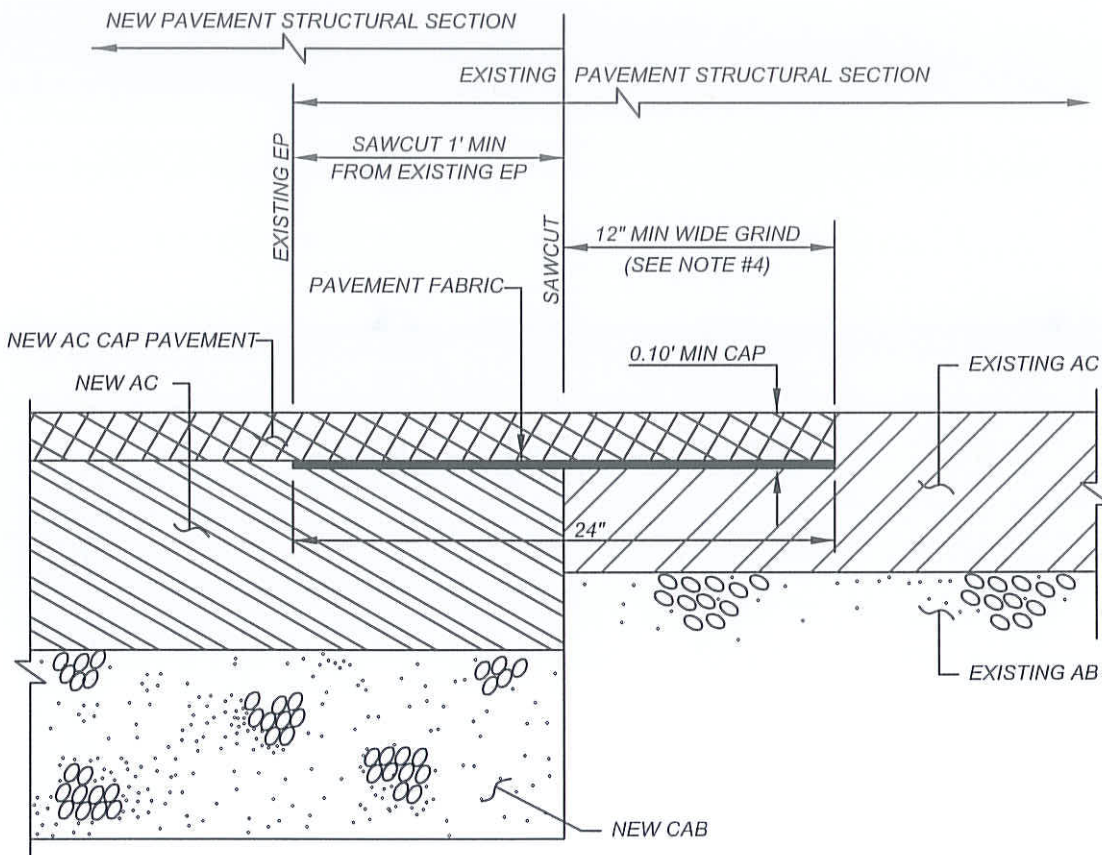

	RECOMMENDED:  DIVISION MANAGER / DATE	<h2 style="margin: 0;">CITY OF MORENO VALLEY</h2> <p style="margin: 0;">PARKS AND COMMUNITY SERVICES DEPARTMENT</p>	STANDARD PLAN <h3 style="margin: 0;">MVGF-623A-1</h3>
	APPROVED:  PUBLIC WORKS DIRECTOR / DATE CITY ENGINEER	<h2 style="margin: 0;">PARKING LOTS</h2>	SHEET 1 OF 11



**NOTES:**

- 1.) THIS STANDARD SHALL APPLY TO PROJECTS THAT REQUIRE NEW PARKING WIDENING OR EXTENSION THAT ABUTS TO EXISTING PARKING.
- 2.) THE NEW PARKING STRUCTURAL SECTION SHALL BE IN ACCORDANCE WITH THE PROJECT'S CITY-APPROVED GEOTECHNICAL REPORT.
- 3.) PAVEMENT FABRIC SHALL BE IN ACCORDANCE WITH THE THE LATEST VERSION OF THE "GREENBOOK" STANDARD SPECIFICATIONS FOR PUBLIC WORKS CONSTRUCTION AND/OR THE PROJECT'S CITY-APPROVED SPECIFICATIONS OR AS RECOMMENDED BY A GEOTECHNICAL ENGINEER/REGISTERED CIVIL ENGINEER AND APPROVED BY THE PARKS AND COMMUNITY SERVICES DEPARTMENT.
- 4.) NEW PAVEMENT SHALL BE EXTENDED TO THE NEAREST LANE LINES AS REQUIRED BY PARKS AND COMMUNITY SERVICES DEPARTMENT.

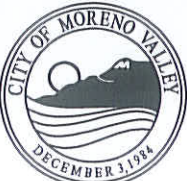
NOT TO SCALE

	RECOMMENDED:  1/21/14 DIVISION MANAGER      DATE	<h2 style="margin: 0;">CITY OF MORENO VALLEY</h2> <p style="margin: 0;">PARKS AND COMMUNITY SERVICES DEPARTMENT</p>	STANDARD PLAN <b>MVGF-623B-0</b>
	APPROVED:  1/29/14 PUBLIC WORKS DIRECTOR / DATE CITY ENGINEER	<h3 style="margin: 0;">JOIN EXISTING PARKING LOT PAVEMENT DETAIL</h3>	



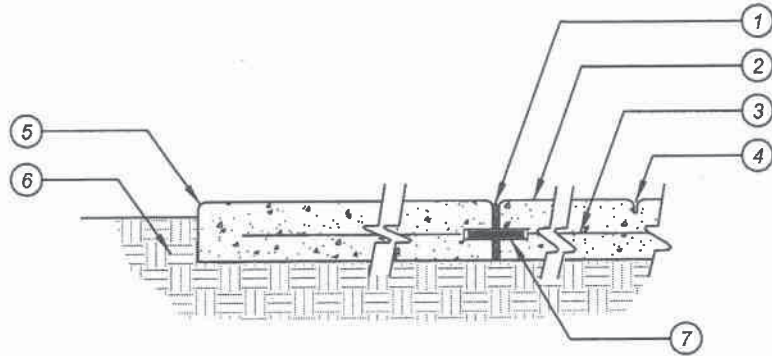



**LEGEND:**

- ① 1/2" REMOVABLE CAP FELT EXPANSION JOINT WITH 2-PART, ELASTOMERIC POLYSULFIDE-BASED JOINT SEALANT. SAND TO MATCH ADJACENT CONCRETE
- ② FINISH SURFACE - SEE CONSTRUCTION LEGEND FOR FINISH
- ③ #4 BAR @ 24" OC, 2 DIRECTIONS, CENTERED IN PAVING (UNLESS OTHERWISE DIRECTED BY SOILS REPORT OR AGENCY)
- ④ 3/4" DEEP MINIMUM SCORE LINE
- ⑤ 1/2" RADIUS TYP
- ⑥ 90% COMPACTED SUBGRADE
- ⑦ SPEED DOWEL @ ALL COLD JOINTS (24" x MIN No 4 BILLET BAR)

**NOTES:**

- 1.) THIS STANDARD TO BE USED FOR REPLACEMENT OF WALKS ON CITY PARKS.
- 2.) 6' WALKS - SCORE AT 6' ON CENTER WITH EXPANSION JOINTS AT 60' ON CENTER.
- 3.) 10' WALKS - SCORE AT 10' ON CENTER WITH EXPANSION JOINTS AT 60' ON CENTER.

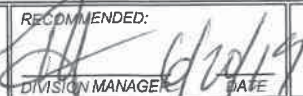
NOT TO SCALE

	RECOMMENDED:  <small>DIVISION MANAGER / DATE</small>	<b>CITY OF MORENO VALLEY</b> PARKS AND COMMUNITY SERVICES DEPARTMENT	STANDARD PLAN
	APPROVED:  <small>PUBLIC WORKS DIRECTOR / DATE</small> <small>CITY ENGINEER</small>	<b>CONCRETE PAVEMENT JOINT</b>	<b>MVGF-623C-1</b>  SHEET 3 OF 11



**TRAFFIC STRIPES AND PAVEMENT MARKING REQUIREMENTS:**

ALL WORK AND MATERIALS SHALL CONFORM TO THE LATEST PROVISIONS SET FORTH IN SECTION 84, "TRAFFIC STRIPES AND PAVEMENT LEGENDS" OF THE STATE OF CALIFORNIA, DEPARTMENT OF TRANSPORTATION STANDARD SPECIFICATIONS, EXCEPT AS NOTED OTHERWISE.

**MATERIALS**

PAINT FOR TRAFFIC STRIPING AND PAVEMENT LEGENDS SHALL BE WHITE, YELLOW, BLUE, RED OR BLACK AS REQUIRED, SHALL BE WATER BORNE TRAFFIC PAINT, FAST DRY CONFORMING TO CALIFORNIA STATE SPECIFICATIONS AND SHALL BE REVIEWED AND APPROVED BY THE PROJECT MANAGER PRIOR TO APPLICATION. ALL STENCILS USED TO PAINT PAVEMENT LEGENDS MUST CONFORM TO THE LATEST CALTRANS APPROVED METRIC STENCILING STANDARDS.

**APPLICATION**

STRIPING AND PAVEMENT LEGENDS SHALL BE APPLIED IN TWO (2) COATS WITH AIRLESS EQUIPMENT. ALL STRIPING SHALL BE PERFORMED WITH A COMMERCIAL STRIPING MACHINE. NO EXCEPTIONS.

THE SECOND COAT OF PAINT SHALL NOT BE APPLIED UNTIL AT LEAST 2 HOURS AFTER THE FIRST COAT. EACH COAT OF PAINT SHALL BE APPLIED AT THE WET FILM THICKNESS OF 10-12 MILS FOR WHITE AND YELLOW PAINT AND 7 MILS FOR BLACK PAINT. ALL PAINT SHALL BE APPLIED AT A RELATIVE HUMIDITY BELOW 75% AND AN AMBIENT TEMPERATURE ABOVE 55 °F, UNLESS WAIVED BY THE PARKS AND COMMUNITY SERVICES DEPARTMENT.

FOR BLUE PAINT, REFLECTIVE GLASS BEADS SHALL BE UNIFORMLY INCORPORATED IN ALL COATS OF PAINT CONCURRENTLY WITH THE APPLICATION OF THE PAINT. THE GLASS BEADS SHALL BE EMBEDDED IN THE COAT OF TRAFFIC PAINT BEING APPLIED TO A DEPTH OF AT LEAST ONE-HALF THEIR DIAMETERS. THE REFLECTIVE GLASS BEADS SHALL BE APPLIED TO THE FIRST COAT OF PAINT AT THE RATE OF 6 POUNDS OF BEADS PER GALLON OF PAINT AND TO THE SECOND COAT OF PAINT AT THE RATE OF 8 POUNDS OF BEADS PER GALLON OF PAINT.

ASPHALT SURFACES SHALL BE DRY, CLEAN, AND FREE OF CONTAMINANTS SUCH AS SURFACE OILS OR EXISTING ROAD MARKING MATERIALS. CONTAMINANTS SHALL BE REMOVED BY MECHANICAL MEANS. MATERIAL SHALL BE APPLIED ONLY WITH EQUIPMENT WHICH IS SPECIFICALLY DESIGNED AND CAPABLE OF PROPERLY MIXING AT THE POINT AND TIME OF APPLICATION.

ANY STRIPING OR PAVEMENT LEGENDS NOT SHOWN ON THE APPROVED PLAN, BUT DEEMED NECESSARY BY PARKS AND COMMUNITY SERVICES, SHALL BE INSTALLED BY THE CONTRACTOR PRIOR TO FINAL ACCEPTANCE OF THE PROJECT.

CONTRACTOR SHALL INSTALL BLUE MARKERS (3M TYPE DB OR EQUAL) ADJACENT TO FIRE HYDRANTS PER CITY STANDARDS MVL-440A-0, MVL-440B-0 AND MVL-440C-0.

NEWLY PAINTED STRIPING AND PAVEMENT LEGENDS SHALL BE PROTECTED FROM DAMAGE BY PUBLIC TRAFFIC OR OTHER CAUSES UNTIL THE PAINT IS THOROUGHLY DRY. ANY EXISTING OR NEWLY PAINTED STRIPING OR PAVEMENT LEGENDS WHICH ARE DAMAGED AS A RESULT OF THE CONSTRUCTION, INCLUDING WHEEL LEGENDS BY PUBLIC TRAFFIC AND THE CONSTRUCTION EQUIPMENT, SHALL BE REPAINTED BY THE CONTRACTOR.

NOT TO SCALE

	RECOMMENDED:  11/21/14 DIVISION MANAGER DATE	<b>CITY OF MORENO VALLEY</b> PARKS AND COMMUNITY SERVICES DEPARTMENT	STANDARD PLAN
	APPROVED:  1/29/14 PUBLIC WORKS DIRECTOR / DATE CITY ENGINEER		<b>PARKS STRIPING &amp; PAVEMENT LEGEND STANDARDS &amp; SPECIFICATIONS</b>





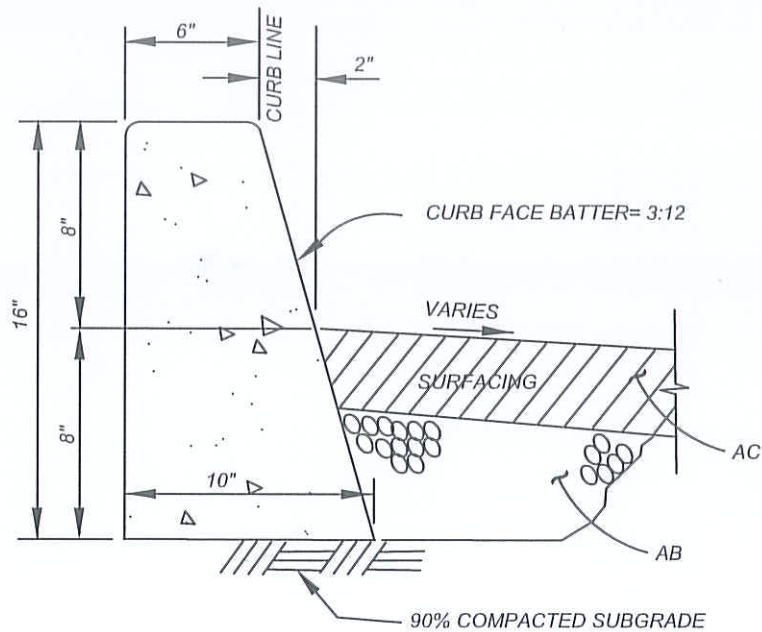

**NOTES:**

- 1.) CONCRETE SHALL BE CLASS 560-C-3250 PCC, CURED WITH PIGMENTED CURING COMPOUND, CLEAN OR COLORED.
- 2.) ALL EXPOSED CORNERS SHALL BE FINISHED WITH  $\frac{1}{2}$ " RADIUS.
- 3.) FINISH SHALL BE FINE BROOM.
- 4.) EXISTING PCC SHALL BE SAWCUT AT JOINT PRIOR TO REMOVAL.
- 5.) CURBS SHALL HAVE EXPANSION JOINTS AT BCR AND ECR AND WEAKENED PLANE JOINTS AT 10' INTERVALS ONLY.
- 6.) WHEN CURB AND GUTTER IS PLACED BY AN EXTRUSION MACHINE, FINISHING WORK SHALL PROVIDE AN ACCEPTABLE FINISH AND WEAKENED PLANE JOINTS MAY BE SAWCUT.
- 7.) INTEGRATED COLOR PER PLANS.

NOT TO SCALE

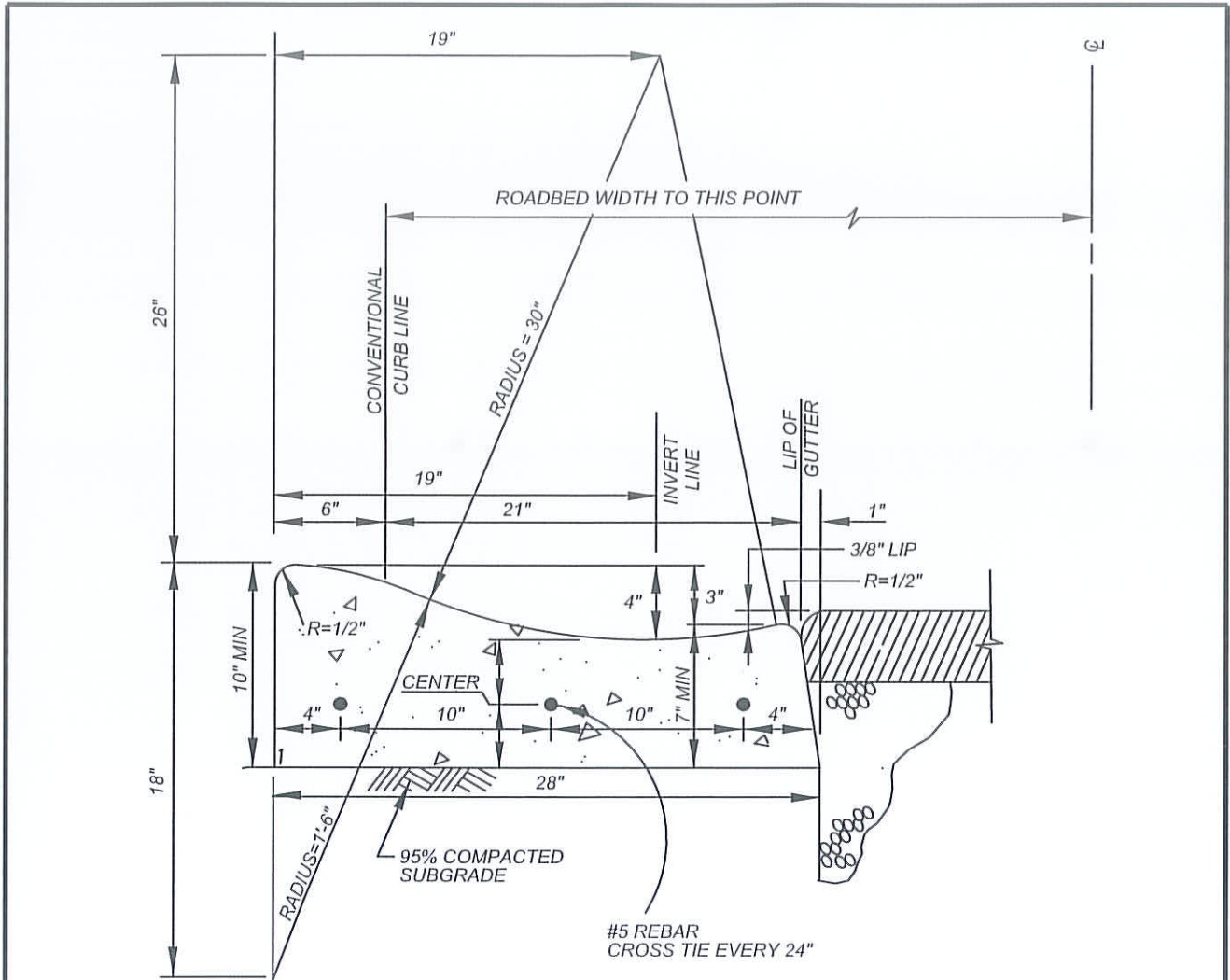

	RECOMMENDED:  DIVISION MANAGER DATE: 1/21/14	<b>CITY OF MORENO VALLEY</b> PARKS AND COMMUNITY SERVICES DEPARTMENT	STANDARD PLAN <b>MVGF-623F-0</b>
	APPROVED:  PUBLIC WORKS DIRECTOR / CITY ENGINEER DATE: 1/29/14	<b>TYPE 8A CURB FOR PARKS</b>	



**NOTES:**

- 1.) CONCRETE SHALL BE CLASS 660-C-4000 PCC, CURED WITH WHITE PIGMENTED CURING COMPOUND.
- 2.) ALL EXPOSED CORNERS SHALL BE FINISHED WITH  $\frac{1}{2}$ " RADIUS.
- 3.) FINISH SHALL BE FINE BROOM.
- 4.) EXISTING PCC SHALL BE SAWCUT AT SCORELINE PRIOR TO REMOVAL.
- 5.) CURBS SHALL HAVE EXPANSION JOINTS AT 60' INTERVALS, AND WEAKENED PLANE JOINTS AT 10' INTERVALS ONLY; NO SCORELINE ALLOWED.
- 6.) WHEN ROLLED CURB IS PLACED BY AN EXTRUSION MACHINE, FINISHING WORK SHALL PROVIDE AN ACCEPTABLE FINISH AND WEAKENED PLANE JOINTS MAY BE SAWCUT.
- 7.) ROLLED CURB MAY BE USED WITH THE APPROVAL OF THE CITY ENGINEER.

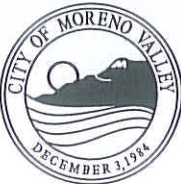
NOT TO SCALE

	RECOMMENDED:  DIVISION MANAGER DATE 1/21/14	<b>CITY OF MORENO VALLEY</b> PARKS AND COMMUNITY SERVICES DEPARTMENT  <b>TYPE C ROLLED CURB FOR PARKS</b>	STANDARD PLAN <b>MVGF-623G-0</b>
	APPROVED:  PUBLIC WORKS DIRECTOR / CITY ENGINEER DATE 1/29/14		SHEET 7 OF 11





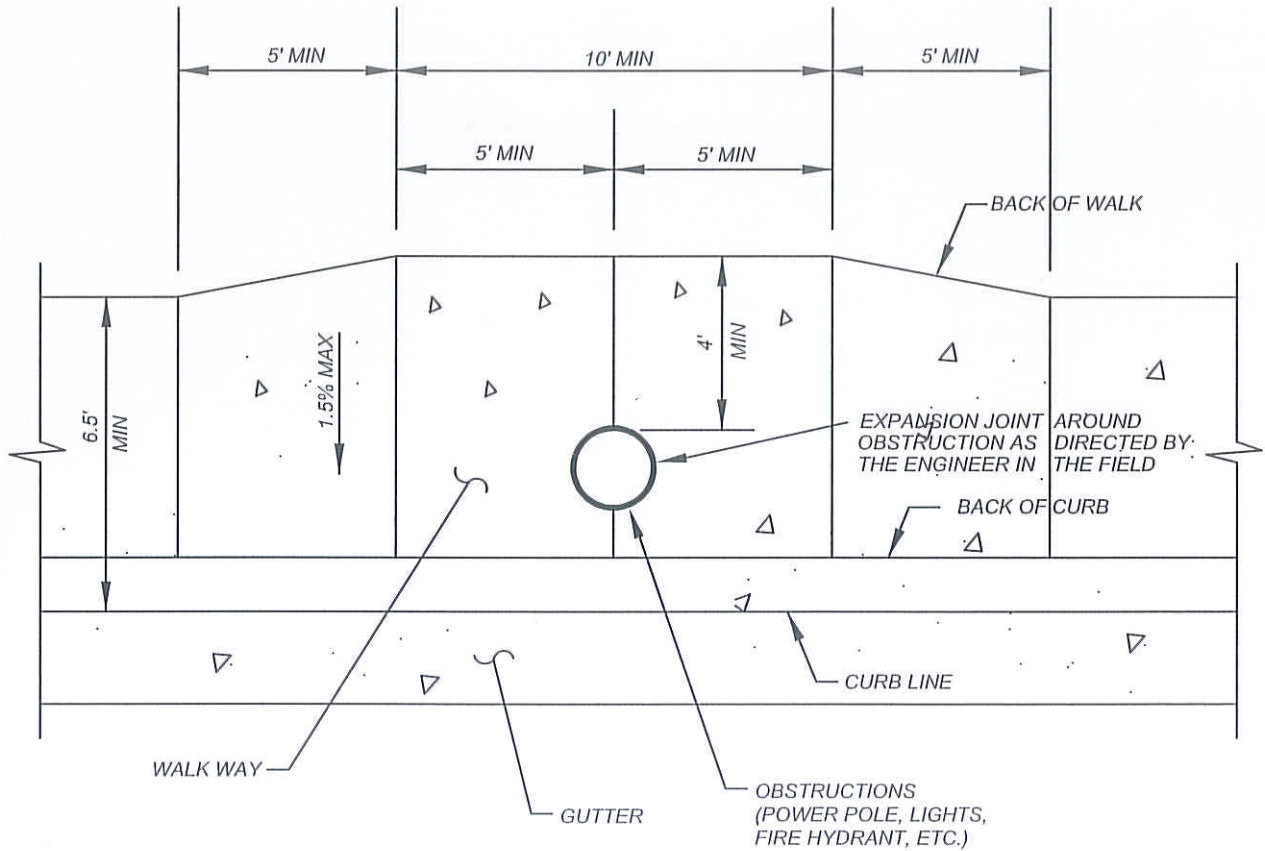



NOTE: CLEARANCE FROM CURB FACE TO FACE OF POLE SHALL BE 18" MINIMUM.

**NOTES:**

- 1.) SIDEWALK SHALL WIDEN TO MINIMUM 4' CLEARANCE FOR A MINIMUM LENGTH OF 10', CENTERED AROUND OBSTRUCTION.
- 2.) MINIMUM TRANSITION LENGTH SHALL BE 5'.
- 3.) ALL CROSS SLOPES ON SIDEWALK SHALL BE 1.5% MAX.

NOT TO SCALE

	RECOMMENDED:  11/21/14 DIVISION MANAGER      DATE	<b>CITY OF MORENO VALLEY</b> PARKS AND COMMUNITY SERVICES DEPARTMENT	STANDARD PLAN <b>MVGF-6231-0</b>
	APPROVED:  1/29/14 PUBLIC WORKS DIRECTOR / DATE CITY ENGINEER	<b>WALK WAY PLACEMENT          AROUND OBSTRUCTIONS          FOR PARKS</b>	SHEET 9 OF 11

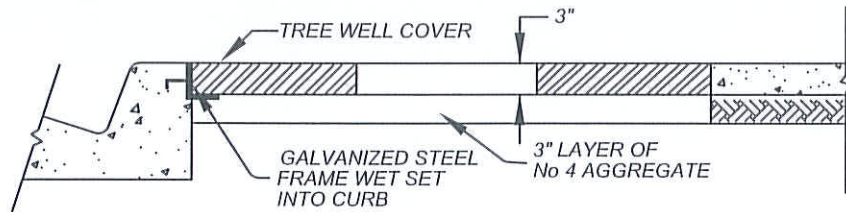
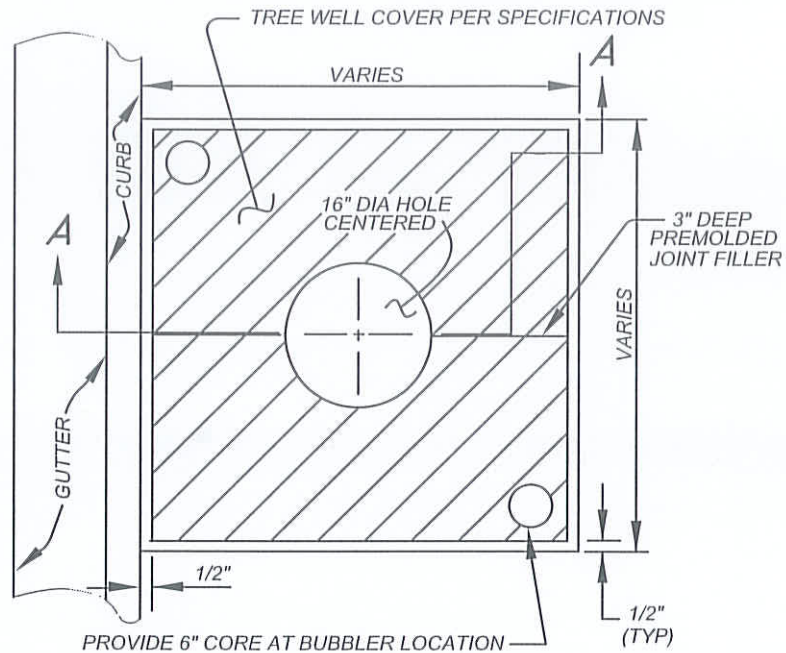

**SECTION "A-A"**

**NOTES:**

- 1.) SEE PROJECT PLANS FOR TYPE OF TREE WELL COVER OR TREE GUARD AND GRATING TO BE USED.
- 2.) ROOT BARRIER SHALL BE FABRICATED FROM A HIGH DENSITY AND HIGH IMPACT PLASTIC SUCH AS POLYVINYL CHLORIDE, ABS OR POLYETHYLENE AND HAVE A MINIMUM THICKNESS OF 0.6 INCH. THE PLASTIC SHALL HAVE 1/2" HIGH RAISED VERTICAL RIBS ON THE INNER SURFACE SPACED NOT MORE THAN 6" APART. INSTALLATION PER MANUFACTURER'S PRINTED INSTRUCTIONS.
- 3.) PLANTING SHALL CONFORM TO SUBSECTION 308-4 OF THE STANDARD SPECIFICATIONS FOR PUBLIC WORKS CONSTRUCTION, EXCEPT THAT:
  - A. THE LOWER 10" OF THE EXCAVATION SHALL BE BACKFILLED WITH PREPARED SOIL MIX AND JETTED PRIOR TO PLACING THE ROOT BARRIER AND THE No 3 CONCRETE AGGREGATE.
  - B. PREPARED SOIL MIX SHALL BE PLACED IN THE PLANTING HOLE AND COMPACTED TO BOTTOM OF ROOT BALL ELEVATION PRIOR TO PROCEEDING WITH TREE PLANTING.
- 4.) AFTER PLANTING, EACH TREE SHALL BE WATERED IMMEDIATELY WITH A MINIMUM OF 20 GALLONS OF WATER. REPEAT THE WATERING TWICE IN THE NEXT 3 DAYS, AT NO CLOSER THAN 24 HOUR INTERVALS.
- 5.) AFTER THE TREE HAS BEEN WATERED FOR THREE DAYS, ALLOW THE SOIL TO DRY SUFFICIENTLY, THEN TAMP AND GRADE THE SOIL. PLACE AND GRADE THE LAYER OF CONCRETE AGGREGATE IN ORDER TO SET THE TREE WELL COVER OR GRATING FIRMLY AND FLUSH WITH THE TOP OF THE SIDEWALK OR CURB.
- 6.) TRUNK TAPERS SHALL NOT BE BELOW THE FINISH GRADE OF PLANTER.

NOT TO SCALE

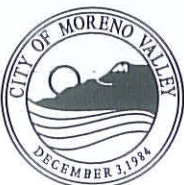

RECOMMENDED:  
  
 DIVISION MANAGER  
 DATE 1/21/14

APPROVED:  
  
 PUBLIC WORKS DIRECTOR / CITY ENGINEER  
 DATE 1/29/14

**CITY OF MORENO VALLEY**  
 PARKS AND COMMUNITY SERVICES DEPARTMENT

**TREE WELL FOR PARKS**

STANDARD PLAN  
**MVGF-623J-0**

SHEET 10 OF 11



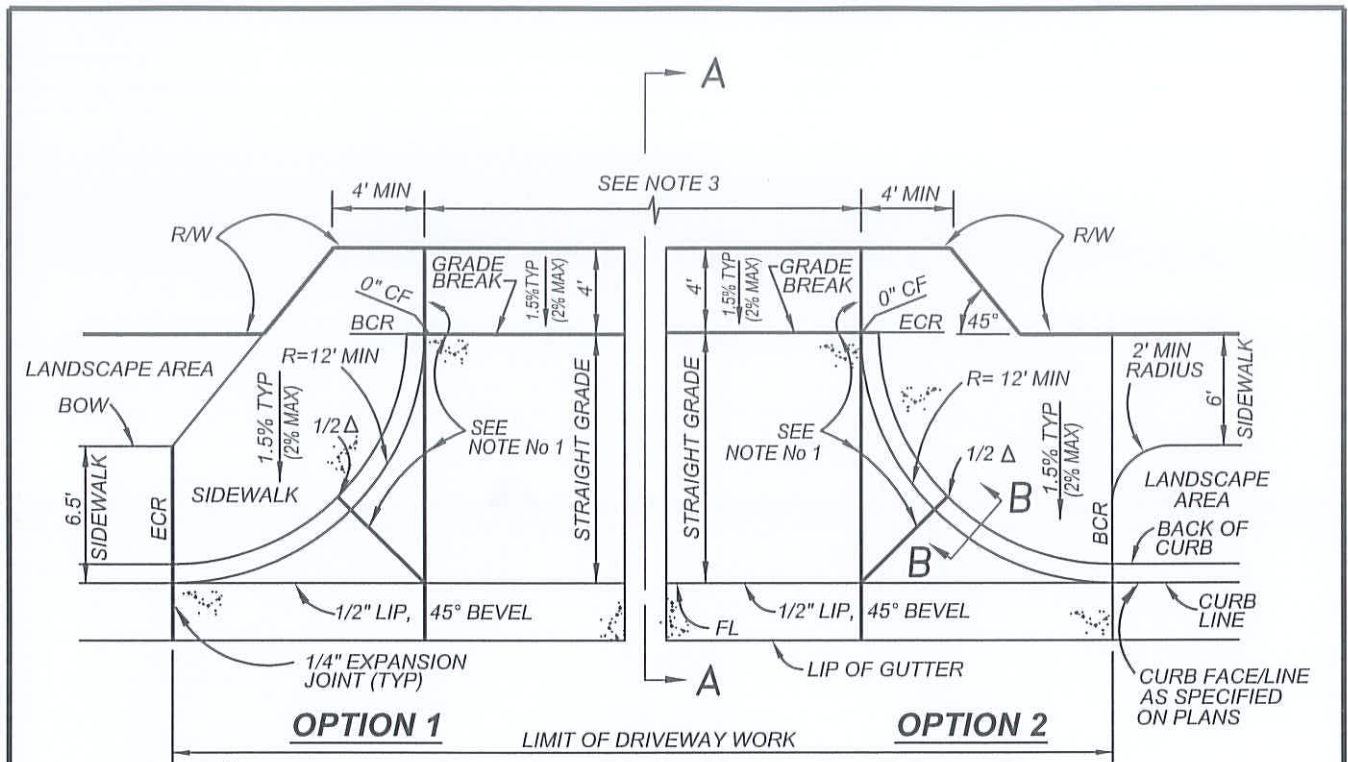

**PLAN VIEW**

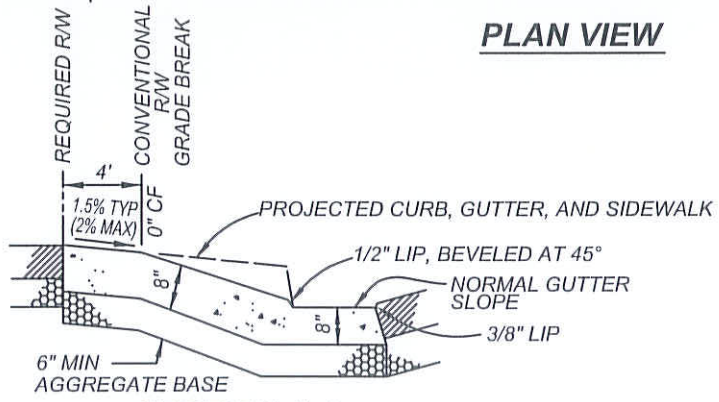

**SECTION A-A**

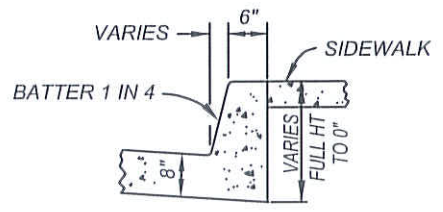

**SECTION B-B**

**NOTES:**

- 1.) WEAKENED PLANE JOINT REQUIRED AT CENTERLINE OF APPROACH AND AT LOCATIONS AS SHOWN, SPACED 10' MAX AS NECESSARY.
- 2.) CONCRETE SHALL BE CLASS 660-C-4000, CURED WITH WHITE PIGMENTED CURING COMPOUND.
- 3.) MINIMUM WIDTH SHALL BE 24', MAXIMUM WIDTH SHALL BE 40'. THIS STANDARD MAY BE USED FOR BIKEWAY APPROACHES IN PARKS WITH WIDTH SHALL BE 16' ONLY.
- 4.) TYPE III APPROACH FOR PARKS AND TRAILS SHALL INCLUDE #4 REBARS AT 18" ON CENTER (2 DIRECTIONS).
- 5.) 4' LONG #4 SMOOTH ROUND BARS SHALL BE USED WHEN DRIVEWAY APPROACH IS NOT POURED MONOLITHIC.
- 6.) MUST COMPLY WITH ADA REQUIREMENTS.

NOT TO SCALE

	RECOMMENDED:  1/29/14 DIVISION MANAGER DATE	<b>CITY OF MORENO VALLEY</b> PARKS AND COMMUNITY SERVICES DEPARTMENT	STANDARD PLAN <b>MVGF-623K-0</b>
	APPROVED:  1/29/14 PUBLIC WORKS DIRECTOR / DATE CITY ENGINEER	<b>COMMERCIAL DRIVEWAY          APPROACH FOR PARKS</b>	



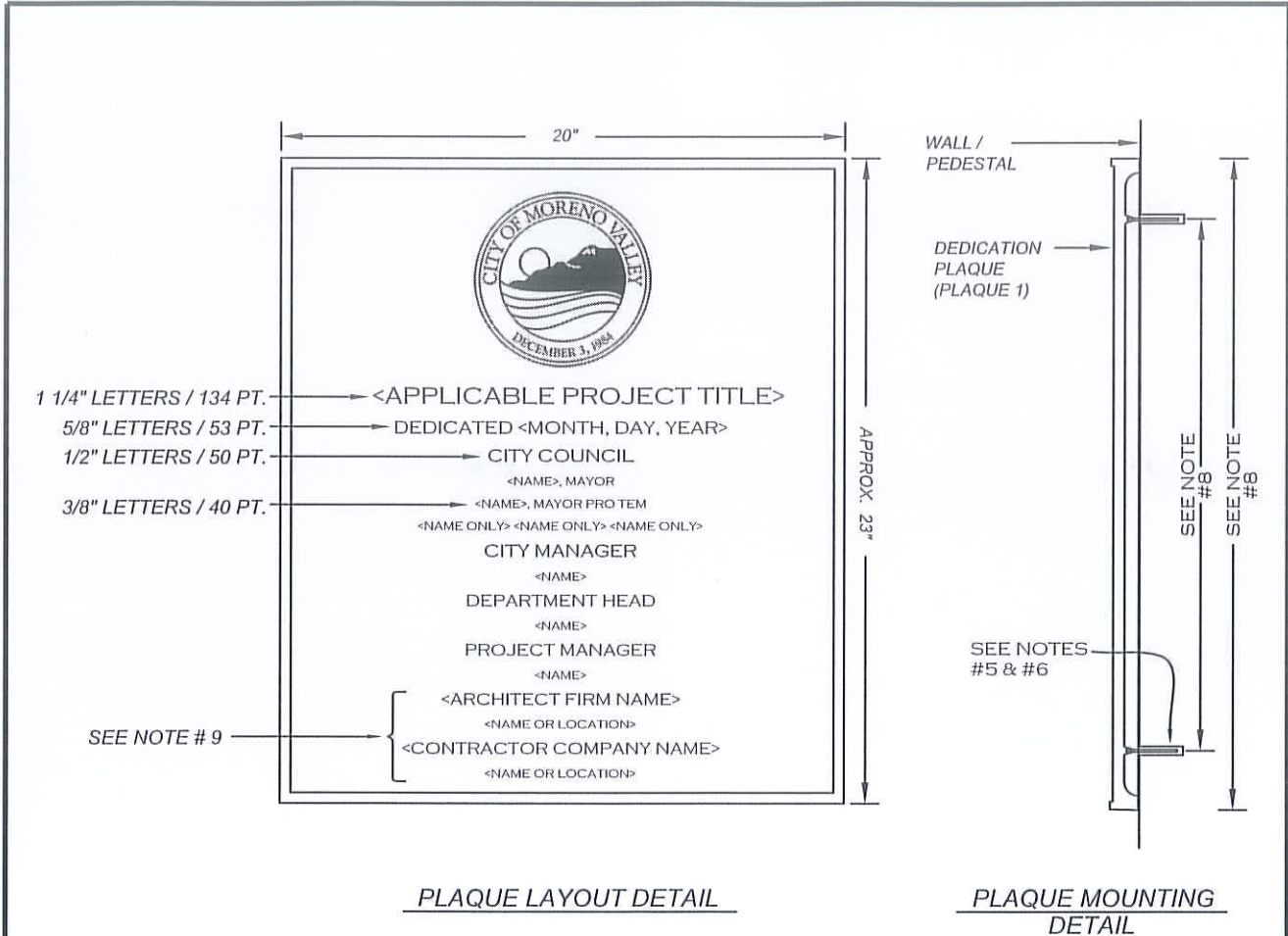



**NOTES:**

1. PLAQUE SHALL HAVE A SATIN FINISH WITH BROWN BACKGROUND AND LEATHERETTE TEXTURE AND PROTECTED WITH A CLEAR ACRYLIC COATING (THIS INCLUDES THE CITY SEAL).
2. THE TYPE/STYLES USED FOR THESE PLAQUES ARE TIMES BOLD AND COPPERPLATE.
3. THE LOCATION FOR THE PLAQUE TO BE DETERMINED BY APPLICABLE DEPARTMENT.
4. PLAQUE EXTENSION (BELOW MAIN PLAQUE) IS TO BE USED WHEN APPLICABLE.
5. MOUNTING STUDS MUST BE EMBEDDED A MINIMUM OF 1 1/2".
6. MOUNTING STUDS SET IN WALL / PEDESTAL WITH APPROVED EPOXY.
7. SEE STANDARD PLAN No MVGF-624A-0 FOR PLAQUE DIMENSIONS AND MAY BE MODIFIED ON A CASE BY CASE BASIS.
8. DIMENSIONS AS RECOMMENDED BY MANUFACTURER.
9. THE NAME OF THE ARCHITECT OR CONTRACTOR (OR BOTH) SHALL ONLY BE SHOWN ON THE PLAQUE IF THE ARCHITECT OR CONTRACTOR (OR BOTH) AGREES TO PAY FOR THE MATERIALS AND INSTALLATION COSTS OF THE PLAQUE.

NOT TO SCALE

	RECOMMENDED:  DIVISION MANAGER DATE: 1/21/14	<h2 style="margin: 0;">CITY OF MORENO VALLEY</h2> <p style="margin: 0;">PARKS AND COMMUNITY SERVICES DEPARTMENT</p>
	APPROVED:  PUBLIC WORKS DIRECTOR / CITY ENGINEER DATE: 1/29/14	<h3 style="margin: 0;">PARKS FACILITY DEDICATION PLAQUE</h3>
SHEET 1 OF 2		

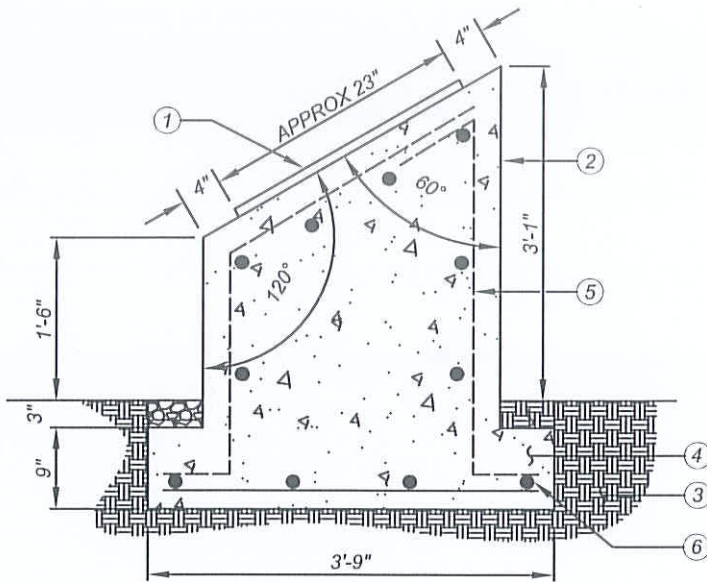

**SIDE ELEVATION**

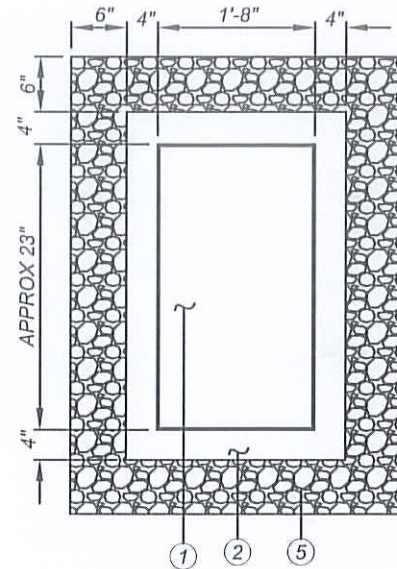

**PLAN VIEW**

**LEGEND:**

- ① DEDICATION PLAQUE
- ② FINISH TYPICALLY TO BE COLORED CONCRETE
- ③ BASE MATERIAL & COMPACTED SUB-GRADE
- ④ STRUCTURAL FOOTING - 3'-9" x 3'-0"
- ⑤ No 4 @ 12" OC EA WAY, TYP
- ⑥ 4- No 4 EA WAY, TYP

**NOTES:**

1. ADJUST SURROUNDING IRRIGATION ACCORDINGLY, IF PLACED IN EXISTING LANDSCAPED AREA.
2. SEAL ALL CONCRETE WITH APPROPRIATE SEALER MATERIAL.
3. 1/8" RADIUS AT ALL CONCRETE EDGES/ CORNERS.

NOT TO SCALE

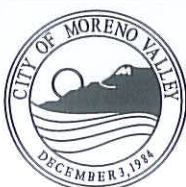

RECOMMENDED:  
  
 DIVISION MANAGER  
 DATE 1/21/14

APPROVED:  
  
 PUBLIC WORKS DIRECTOR / CITY ENGINEER  
 DATE 1/29/14

**CITY OF MORENO VALLEY**

PARKS AND COMMUNITY SERVICES DEPARTMENT

**PARKS DEDICATION PLAQUE  
 PEDESTAL**

STANDARD PLAN  
**MVGF-624B-0**

SHEET 2 OF 2

RIVET LOCATIONS  
(SEE NOTE 6 ON  
STD MVGF-625A-0)

DIRECTION OF  
TRAFFIC FLOW

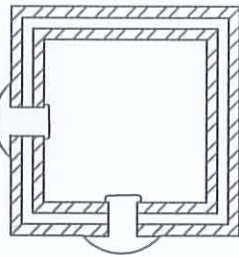

SECTION "A-A"

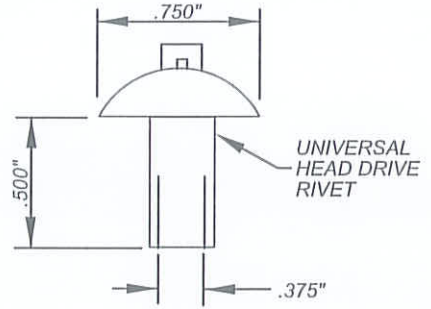

RIVET  
DETAIL

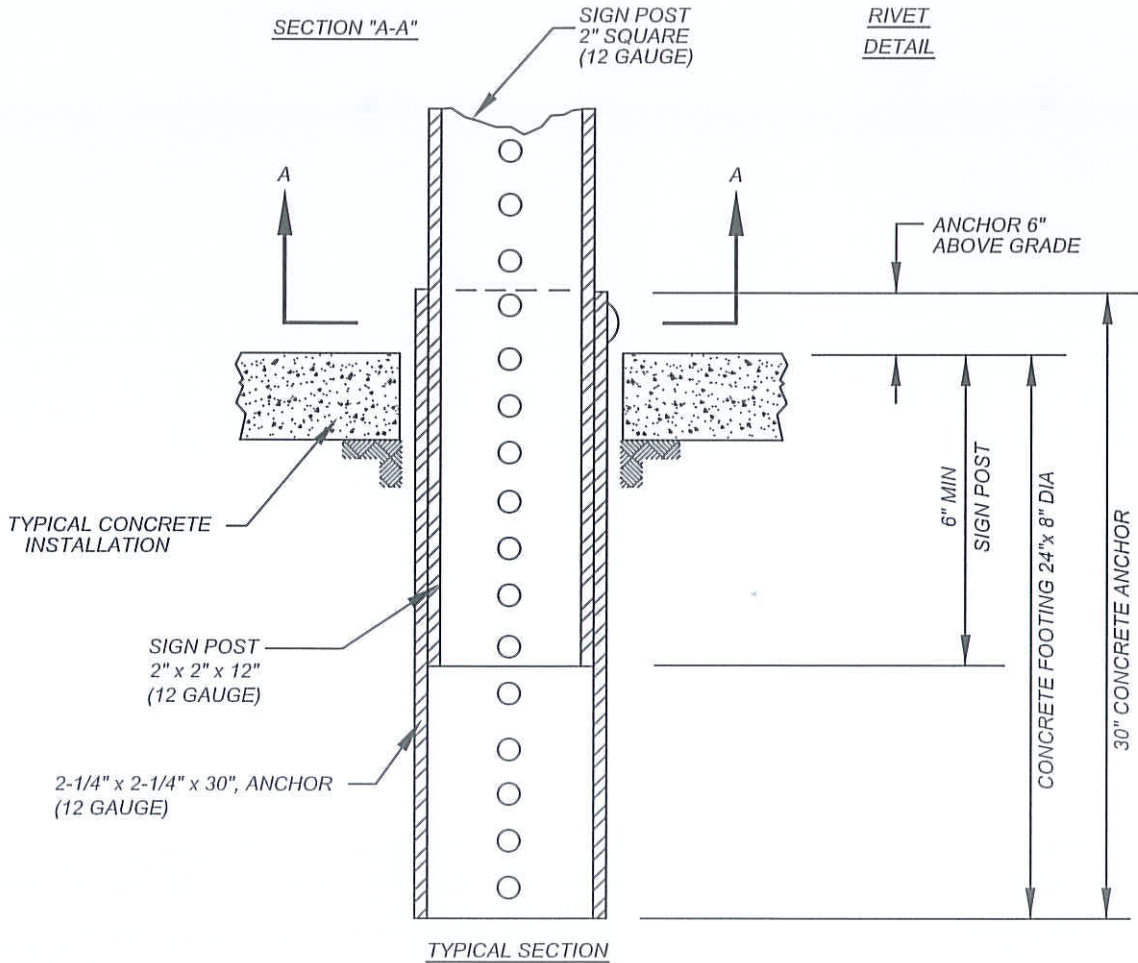

TYPICAL SECTION

**NOTE:**

IN TURF/PLANTERS, INSTALL INTO CONCRETE FOOTING.

NOT TO SCALE

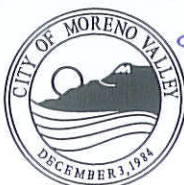

RECOMMENDED:  
*[Signature]* 1/29/14  
DIVISION MANAGER DATE  
APPROVER:  
*[Signature]* 1/29/14  
PUBLIC WORKS DIRECTOR / DATE  
CITY ENGINEER

**CITY OF MORENO VALLEY**

PARKS AND COMMUNITY SERVICES DEPARTMENT

**SIGN POST INSTALLATION  
IN PARKS**

STANDARD PLAN  
**MVGF-625A-0**

SHEET 1 OF 2



**NOTES:**

- 1.) SQUARE PERFORATED STEEL TUBE POSTS WITH TWO PIECE ANCHOR AND SLEEVE, "TELESPAR", SHALL BE USED FOR ALL PARK PROJECTS.
- 2.) THE NUMBER OF POSTS REQUIRED FOR SIGN INSTALLATION SHALL BE DETERMINED BY THE AREA OF THE SIGN OR COMBINATION OF SIGNS TO BE INSTALLED. A SINGLE POST SHALL BE USED WHERE BOTH THE LENGTH AND WIDTH ARE 48" OR LESS. DOUBLE POSTS SHALL BE USED WHERE EITHER THE LENGTH OR THE WIDTH EXCEEDS 48".
- 3.) THE 2 PIECE ANCHOR ASSEMBLY SHALL CONSIST OF A 2 1/4" SQUARE ANCHOR AND SHALL BE 12 GAUGE.
- 4.) THE ANCHOR ASSEMBLY SHALL BE DRIVEN SIMULTANEOUSLY UNTIL ONLY 6" REMAINS ABOVE GROUND LEVEL.
- 5.) ALL DEBRIS SHALL BE REMOVED FROM THE INSIDE TOP 12" MIN OF THE ANCHOR ASSEMBLY TO ALLOW FOR INSTALLATION OF THE SIGN POST.
- 6.) INSTALL THE 2" SQUARE SIGN POST MINIMUM 12" INTO THE ANCHOR ASSEMBLY AND SECURE IN PLACE WITH TWO 3/8" DRIVE RIVETS AS SHOWN. THE RIVETS SHALL BE INSTALLED ON THE SIDE FACING TRAFFIC FLOW.
- 7.) THE BOTTOM OF THE SIGN SHALL BE A MINIMUM OF 7 FEET ABOVE THE FINISHED SURFACE.
- 8.) SEE STANDARD MVGF-625A-0 FOR PLACEMENT OF SIGN POST. SIGN POST SHALL BE PLACED 24" MINIMUM FROM TRAFFIC OR PEDESTRIAN FLOW.
- 9.) ALL ANCHOR ASSEMBLIES SHALL BE PLACED IN A 2000PSI CONCRETE FOOTING, 24" DEEP x 8" DIAMETER.

NOT TO SCALE

	RECOMMENDED:  1/21/14 DIVISION MANAGER      DATE	<b>CITY OF MORENO VALLEY</b> PARKS AND COMMUNITY SERVICES DEPARTMENT	STANDARD PLAN
	APPROVED:  1/29/14 PUBLIC WORKS DIRECTOR / DATE CITY ENGINEER		<b>PARKS SIGN POST INSTALLATION NOTES</b>
			SHEET 2 OF 2



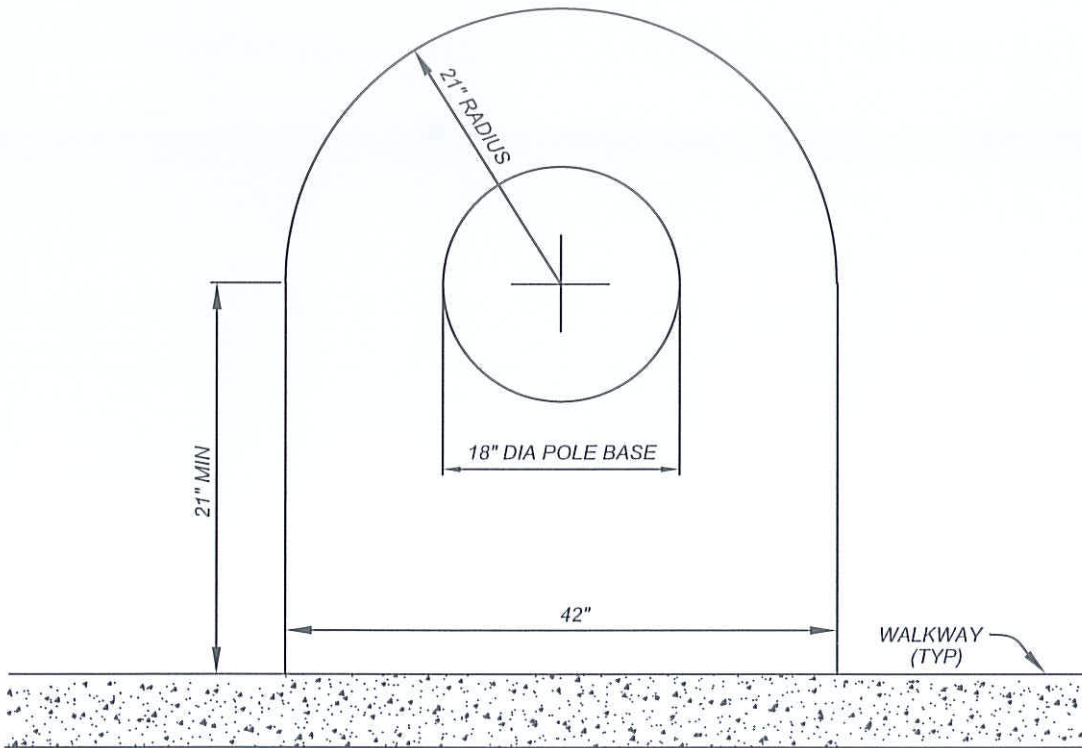



**CONCRETE BASE SKIRT  
FOR LIGHT POLE**

**NOTES:**

- 1.) ALL CONCRETE SHALL BE MINIMUM 560C-3250, MINIMUM 6" THICK.
- 2.) CONCRETE SHALL BE SAME COLOR AND FINISH OF ADJACENT WALK WAY UNLESS STATED OTHERWISE.

NOT TO SCALE

	RECOMMENDED:  1/21/14 DIVISION MANAGER DATE	<b>CITY OF MORENO VALLEY</b> PARKS AND COMMUNITY SERVICES DEPARTMENT	
	APPROVED:  1/29/14 PUBLIC WORKS DIRECTOR / DATE CITY ENGINEER	<b>CONCRETE LIGHT POLE BASE</b>	
			SHEET 1 OF 1

**GENERAL NOTES:**

1. ALL CONSTRUCTION AND WORKMANSHIP SHALL CONFORM TO THE CALIFORNIA BUILDING CODE (CBC), LATEST EDITION. NOTE ALL REFERENCES ON PLANS TO SECTION AND TABLES REFER TO THE CBC, LATEST EDITION.
2. THESE NOTES SHALL BE USED IN CONJUNCTION WITH THE PLANS AND ANY DISCREPANCIES SHALL BE BROUGHT TO THE ATTENTION OF THE ARCHITECT AND THE ENGINEER.
3. CONTRACTOR MUST CHECK DIMENSIONS, FRAMING CONDITIONS, AND SITE CONDITIONS BEFORE STARTING WORK. ARCHITECT AND THE ENGINEER SHALL BE NOTIFIED IMMEDIATELY OF ANY DISCREPANCIES OR POSSIBLE DEFICIENCIES.
4. CONDITIONS NOT SPECIFICALLY DETAILED SHALL BE CONSTRUCTED AS SPECIFIED IN TYPICAL DETAILS FOR THE RESPECTIVE MATERIALS.
5. THE DRAWING AND SPECIFICATIONS REPRESENT THE FINISH STRUCTURE. ALL BRACING, TEMPORARY SUPPORTS, SHORING, ETC. IS THE SOLE RESPONSIBILITY OF THE CONTRACTOR. OBSERVATION VISITS TO THE JOB SITE BY THE ARCHITECT AND THE ENGINEER DO NOT INCLUDE INSPECTION OF CONSTRUCTION PROCEDURES. THESE VISITS SHALL NOT BE CONSTRUED AS CONTINUOUS AND DETAILED INSPECTIONS. THE CONTRACTOR IS SOLELY RESPONSIBLE FOR ALL CONSTRUCTION METHODS AND SAFETY CONDITIONS AT THE WORK SITE.
6. DESCRIBED BELOW OR INDICATED ON THE DRAWINGS MAY BE CONSIDERED FOR USE, PROVIDED PRIOR APPROVAL IS OBTAINED FROM THE OWNER, ARCHITECT, AND THE ENGINEER, AND ALL APPLICABLE GOVERNING CODE AUTHORITY.

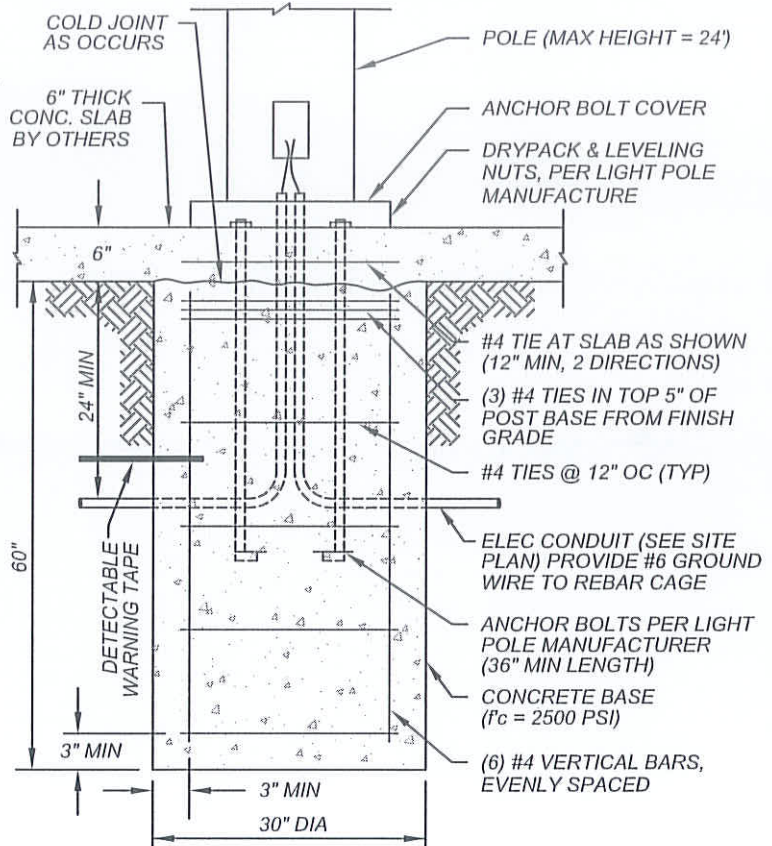

**NOTE:** THIS STANDARD PLAN WAS REVIEWED AND APPROVED BY THE COMMUNITY DEVELOPMENT DEPARTMENT, PLANNING AND BUILDING AND SAFETY DIVISIONS. COPY OF THE STAMP APPROVED STANDARD IS ON FILE WITH THE CAPITAL PROJECTS DIVISION.



**REINFORCING STEEL:**

1. REINFORCING STEEL SHALL CONFORM TO ASTM 615, GRADE 40 FOR SIZE #3 AND #4, AND GRADE 60 FOR SIZES #5 AND LARGER.
2. ALL BENDING OF REINFORCING STEEL SHALL CONFORM TO THE LATEST EDITION OF THE CBC.
3. ALL REINFORCING BARS SHALL BE ACCURATELY AND SECURELY PLACED BEFORE POURING CONCRETE OR GROUTING MASONRY.

**CONCRETE:**

1. ALL CONCRETE SHALL ATTAIN A MINIMUM COMPRESSIVE STRENGTH OF 2500 PSI AT 28 DAYS, UNLESS NOTED OTHERWISE ON PLANS.
2. AGGREGATES SHALL BE NATURAL SAND AND ROCK CONFORMING TO ASTM C33.
3. CEMENT SHALL BE PORTLAND CEMENT CONFORMING TO ASTM C150, AS REQUIRED TO SATISFY SITE CONDITIONS AS DETERMINED BY THE PROJECT SOILS ENGINEER OR TYPE II CEMENT WITH MAXIMUM WATER/CEMENT RATIO = 0.65.
4. PIPES MAY PASS THROUGH STRUCTURAL CONCRETE IN SLEEVES, BUT SHALL NOT BE EMBEDDED THEREIN. PIPES OR DUCTS EXCEEDING ONE-THIRD THE SLAB OR WALL THICKNESS SHALL NOT BE PLACED IN THE STRUCTURAL CONCRETE UNLESS SPECIFICALLY DETAILED.
5. ALL CONVENTIONAL FOUNDATION ARE DESIGNED FOR AN EI OF LESS THAN OR EQUAL TO 20, UNLESS SPECIFICALLY NOTED OTHERWISE ON PLANS.
6. REFER TO ACI 318-05, TABLE 4.3.1 FOR REQUIREMENTS WHEN CONCRETE IS EXPOSED TO SULFATE CONTAINING SOLUTIONS.

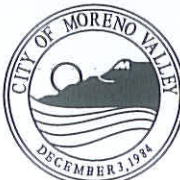
NOT TO SCALE

	RECOMMENDED:  11/21/14 DIVISION MANAGER DATE	<b>CITY OF MORENO VALLEY</b> PARKS AND COMMUNITY SERVICES DEPARTMENT	STANDARD PLAN
	APPROVED:  11/29/14 PUBLIC WORKS DIRECTOR / DATE CITY ENGINEER		<b>POLE BASE FIXTURE FOOTING FOR PARKS</b>
			SHEET 1 OF 2



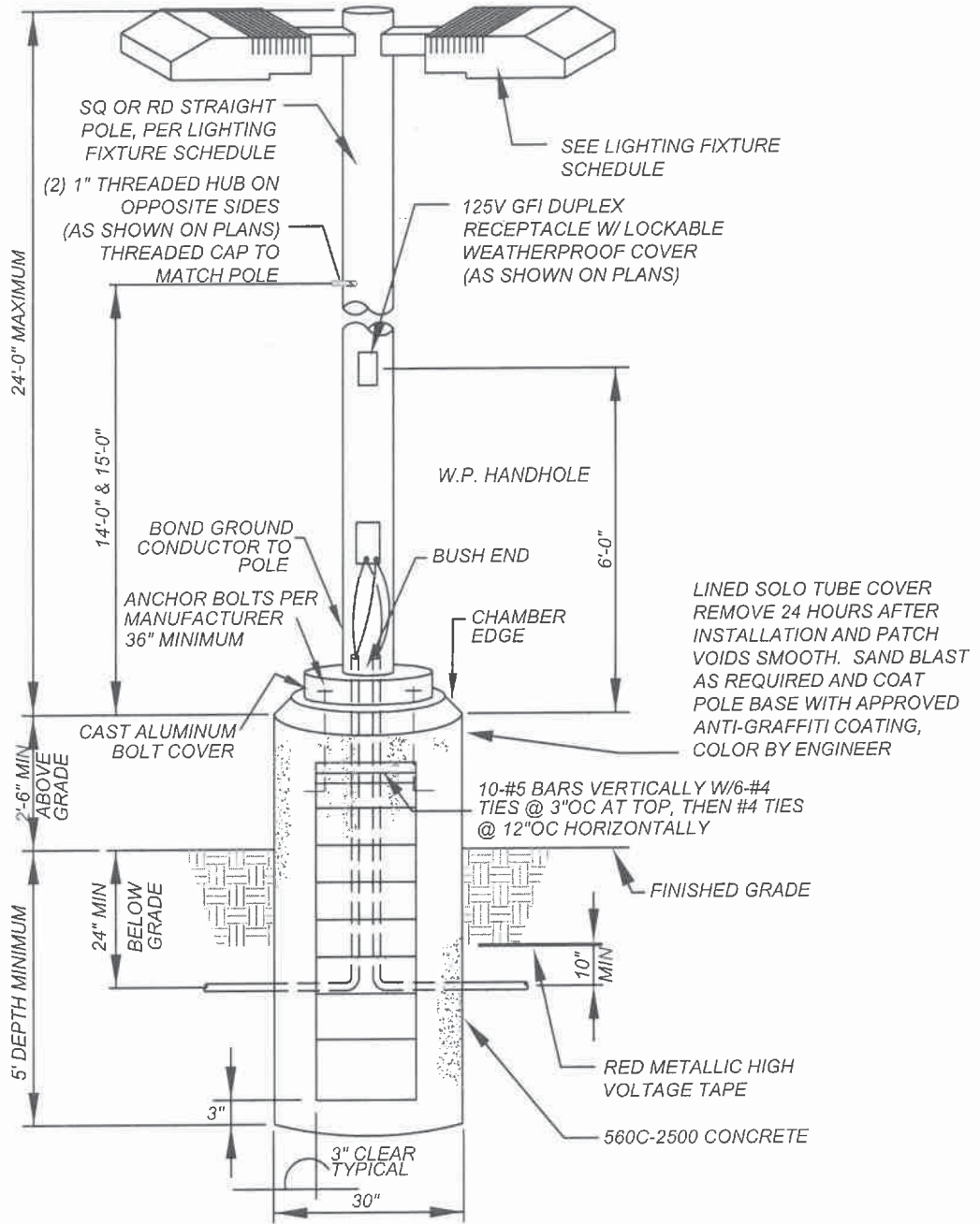



**NOTES:**

1. VERIFY BOLT PLACEMENT WITH POLE MANUFACTURER PRIOR TO ROUGH-IN.
2. THIS STANDARD PLAN WAS REVIEWED AND APPROVED BY THE COMMUNITY DEVELOPMENT DEPARTMENT, PLANNING AND BUILDING AND SAFETY DIVISIONS. COPY OF THE STAMP APPROVED STANDARD AND STRUCTURAL CALCULATIONS ARE ON FILE WITH THE CAPITAL PROJECTS DIVISION.

NOT TO SCALE

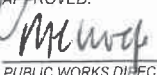
	RECOMMENDED:  DIVISION MANAGER DATE: 9/20/19	<b>CITY OF MORENO VALLEY</b> PARKS AND COMMUNITY SERVICES DEPARTMENT	
	APPROVED:  PUBLIC WORKS DIRECTOR / DATE: 10/14/19 CITY ENGINEER	<b>LIGHT POLE WITH ABOVE GRADE POLE BASE</b>	





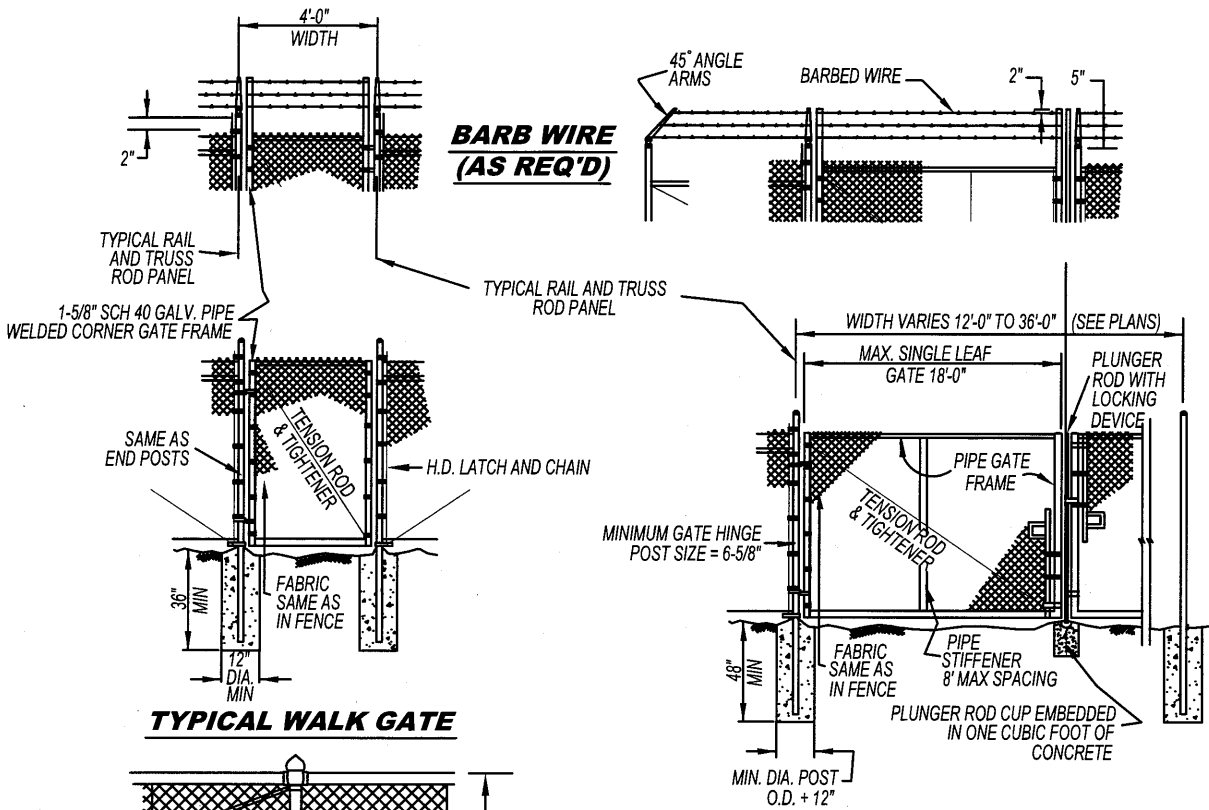

**TYPICAL WALK GATE**

**TYPICAL DRIVE GATE**

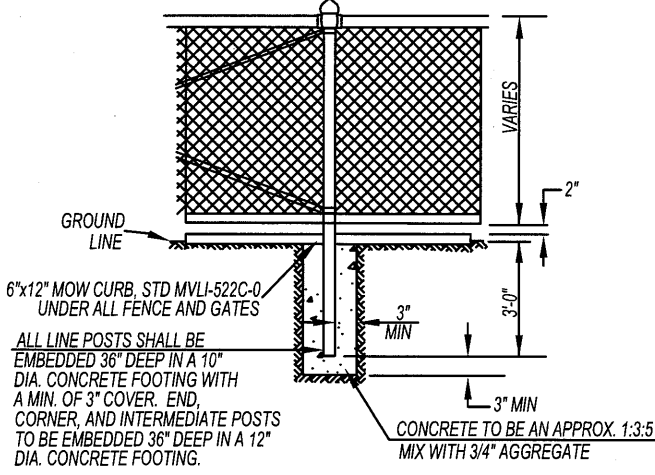

**TYPICAL FENCE POST FOOTING EMBEDMENT DETAIL**

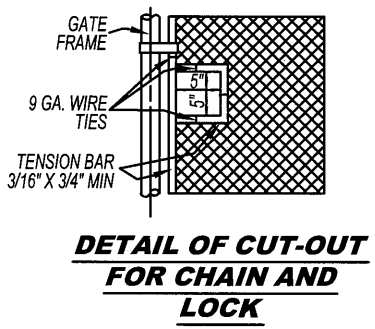



**DETAIL OF CUT-OUT FOR CHAIN AND LOCK**

**NOTES:**

- 1.) SECURE DRIVE FIT GALVANIZED CAP TO POST WITH 1/4" ROUND HEAD RIVET.
- 2.) TYPICAL HEIGHT IS 6'-0" UNLESS OTHERWISE SPECIFIED. MID RAILS ARE REQUIRED ON FENCE OVER 6'.
- 3.) 6' CHAIN LINK FENCE TO HAVE TOP AND BOTTOM RAIL. RAILS AT INTERMEDIATE, END, AND ANY CHANGE OF DIRECTION.
- 4.) TYPICAL FABRIC IS 2", 9 GA. GAW, WITH KNUCKLED (KK) SELVAGED ENDS. 3 GA. COLOR VINYL OVER FABRIC AS SPECIFIED.
- 5.) ALL DATA SHOWN ON TYPICAL DETAILS SHALL BE APPLICABLE TO OTHER PERTINENT DETAILS AND PARK SPECIFICATIONS.
- 6.) THE GALVANIZING OF THE FENCE FABRIC SHALL PRODUCE A ZINC COATING WEIGHING NOT LESS THAN 1.2 OZ. PER SQ. FT.
- 7.) POSTS AND RAILS TO BE SCH 40 OR SS 40 (UNLESS OTHERWISE SPECIFIED).
- 8.) VINYL COATED FENCING REQUIRES VINYL COATED POSTS AND FITTINGS OVER GALVANIZED COATING
- 9.) MINIMUM LINE POST SIZE IS 2-3/8". MINIMUM TERMINAL POST SIZE IS 2-7/8".

NOT TO SCALE

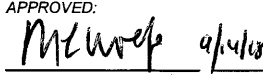
	RECOMMENDED:  DIVISION MANAGER      DATE 3/5/18	<h2 style="margin: 0;">CITY OF MORENO VALLEY</h2> <p style="margin: 0;">PARKS AND COMMUNITY SERVICES DEPARTMENT</p>	STANDARD PLAN <h3 style="margin: 0;">MVGF-641-0</h3>
	APPROVED:  PUBLIC WORKS DIRECTOR / DATE CITY ENGINEER	<h3 style="margin: 0;">PARK PROJECTS CHAIN LINK FENCE AND GATES</h3>	

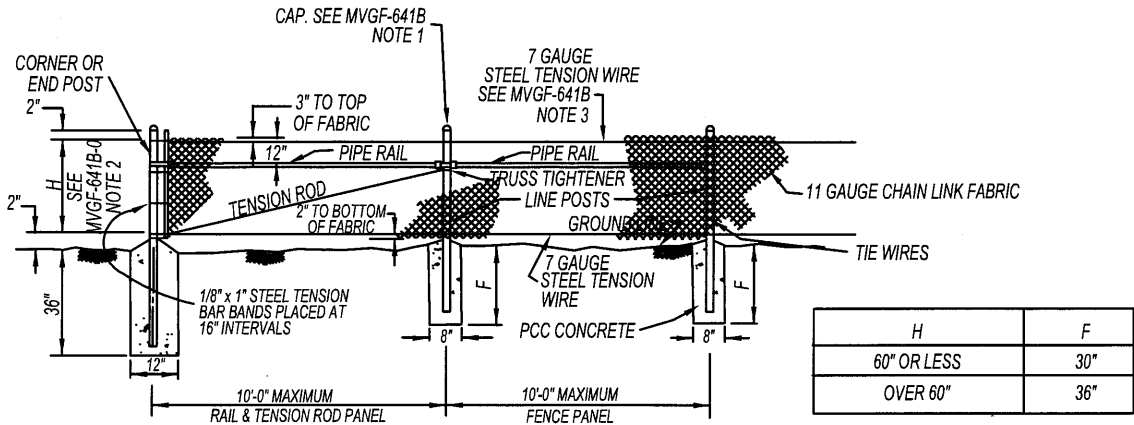

H	F
60" OR LESS	30"
OVER 60"	36"

**TYPICAL FENCE ELEVATION**

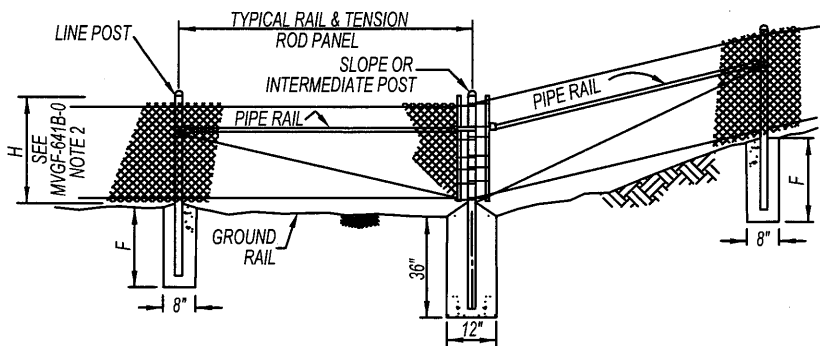

INTERMEDIATE AND SLOPE POSTS SHALL BE INSTALLED AT NOT MORE THAN 300' INTERVALS ALONG FENCE LINE AND AT GRADE CHANGES EXCEEDING 5% ALSO APPLICABLE TO CHANNEL FENCE

**INTERMEDIATE POST DETAIL**

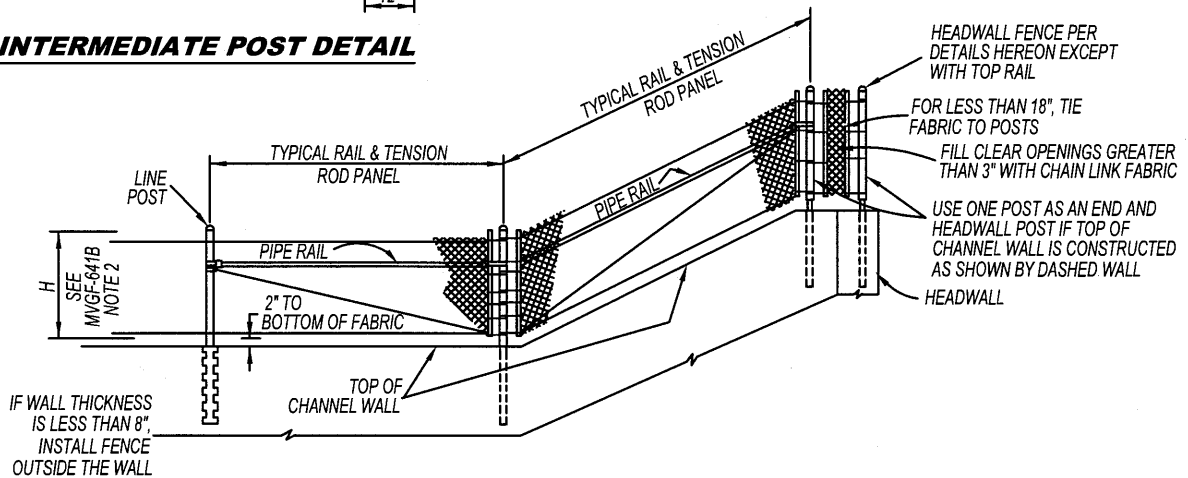

**CHANNEL WALL AND WINGWALL DETAIL AT HEADWALL**

NOT TO SCALE

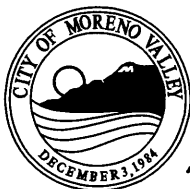

RECOMMENDED: *[Signature]*  
 DIVISION MANAGER DATE  
 APPROVED: *[Signature]*  
 PUBLIC WORKS DIRECTOR / DATE  
 CITY ENGINEER

**CITY OF MORENO VALLEY**

PARKS AND COMMUNITY SERVICES DEPARTMENT

**FENCE AND GATES FOR WALL AND CHANNEL**

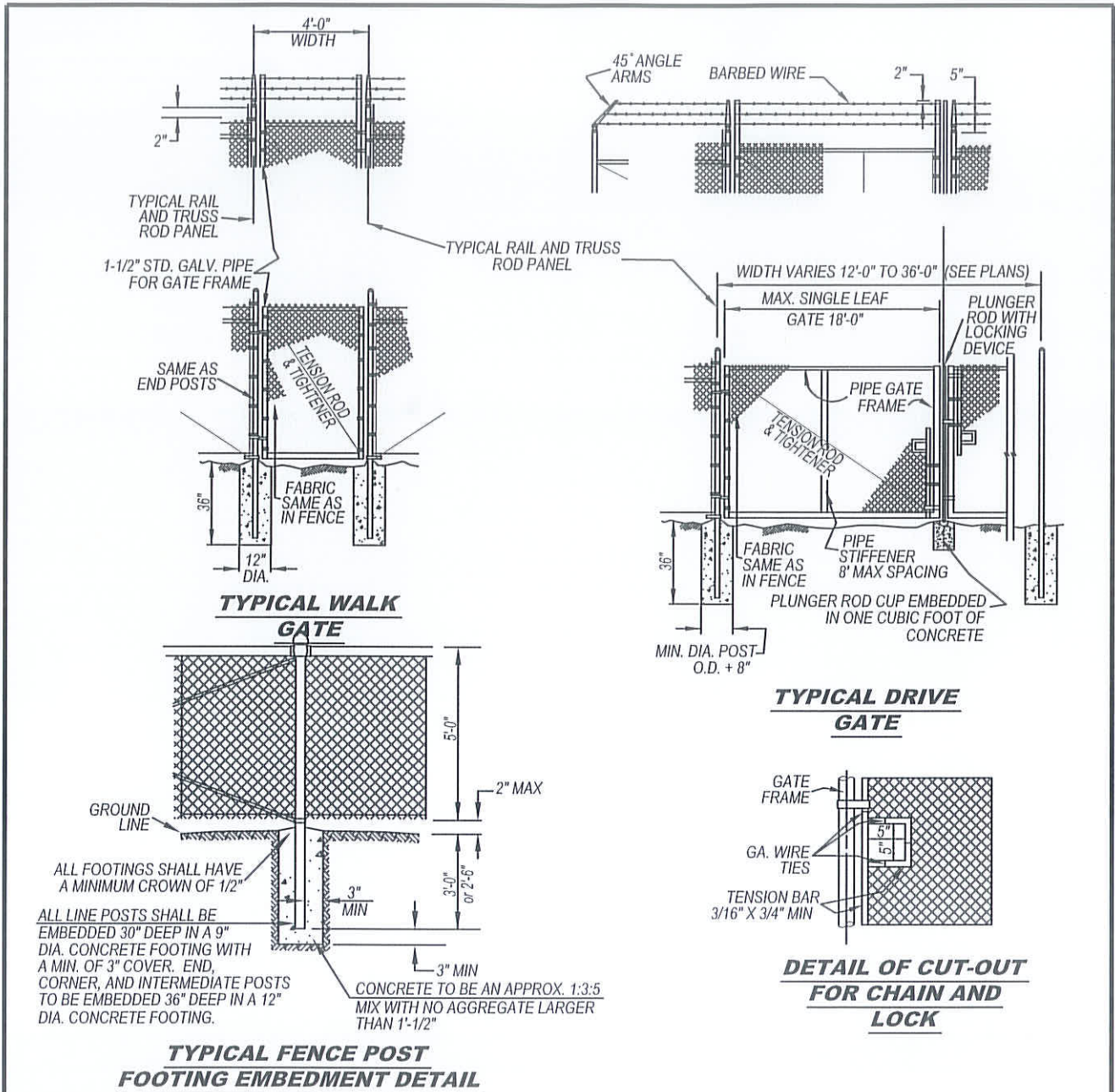

STANDARD PLAN  
**MVGF-641A-0**  
 SHEET 1 OF 3



**NOTES:**

- 1.) SECURE DRIVE FIT GALVANIZED CAP TO POST WITH 1/4" ROUND HEAD RIVET.
- 2.) H DENOTES FABRIC WIDTH AND NORMAL FENCE HEIGHT. H SHALL BE 5'-0" UNLESS OTHERWISE SPECIFIED.
- 3.) IF CHAIN LINK FENCE WITH TOP RAIL IS SPECIFIED. DELETE STEEL TENSION WIRE AT THE TOP AND THE PIPE RAILS AT THE INTERMEDIATE, END AND CORNER POSTS. EXTEND TENSION ROD TO THE TOP RAIL.
- 4.) BARBED WIRE SHALL BE USED ONLY WHEN SPECIFIED.
- 5.) ALL DATA SHOWN ON TYPICAL DETAILS SHALL BE APPLICABLE TO OTHER PERTINENT DETAILS.
- 6.) THE GALVANIZING OF THE FENCE FABRIC SHALL PRODUCE A ZINC COATING WEIGHING NOT LESS THAN 1.2 OZ. PER SQ. FT..

NOT TO SCALE



	RECOMMENDED:  DIVISION MANAGER DATE 1/21/14	<h2 style="margin: 0;">CITY OF MORENO VALLEY</h2> <p style="margin: 0;">PARKS AND COMMUNITY SERVICES DEPARTMENT</p>	STANDARD PLAN <h3 style="margin: 0;">MVGF-641B-0</h3>
	APPROVED:  PUBLIC WORKS DIRECTOR / CITY ENGINEER DATE 1/29/14	<h3 style="margin: 0;">HIGHWAY CHAIN LINK FENCE AND GATES</h3>	SHEET 2 OF 3

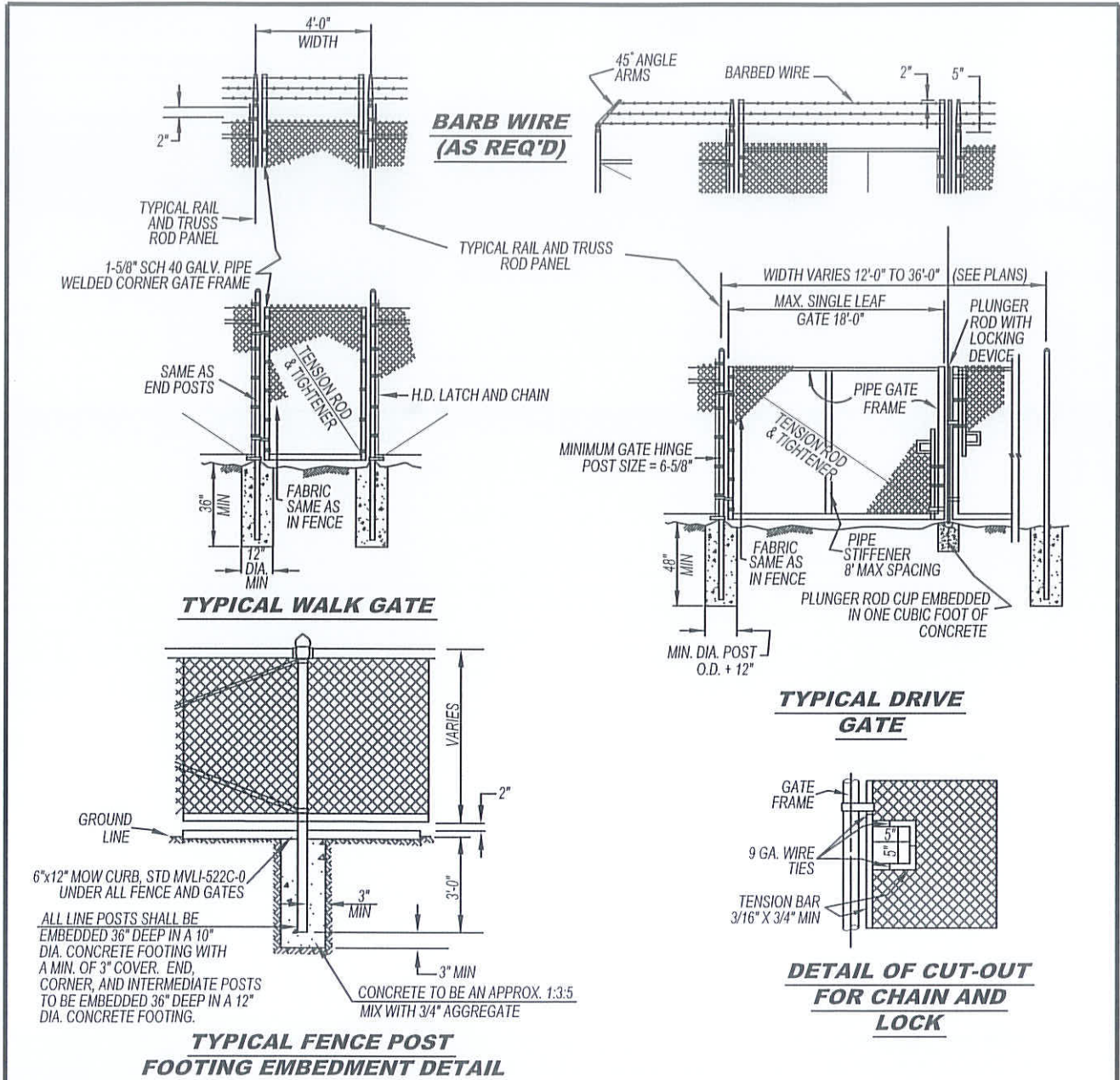



- NOTES:**
- 1.) SECURE DRIVE FIT GALVANIZED CAP TO POST WITH 1/4" ROUND HEAD RIVET.
  - 2.) TYPICAL HEIGHT IS 6'-0" UNLESS OTHERWISE SPECIFIED. MID RAILS ARE REQUIRED ON FENCE OVER 6'.
  - 3.) 6" CHAIN LINK FENCE TO HAVE TOP AND BOTTOM RAIL. RAILS AT INTERMEDIATE, END, AND ANY CHANGE OF DIRECTION.
  - 4.) TYPICAL FABRIC IS 2", 9 GA. GAW, WITH KNUCKLED (KK) SELVAGED ENDS. 3 GA. COLOR VINYL OVER FABRIC AS SPECIFIED.
  - 5.) ALL DATA SHOWN ON TYPICAL DETAILS SHALL BE APPLICABLE TO OTHER PERTINENT DETAILS AND PARK SPECIFICATIONS.
  - 6.) THE GALVANIZING OF THE FENCE FABRIC SHALL PRODUCE A ZINC COATING WEIGHING NOT LESS THAN 1.2 OZ. PER SQ. FT.
  - 7.) POSTS AND RAILS TO BE SCH 40 OR SS 40 (UNLESS OTHERWISE SPECIFIED).
  - 8.) VINYL COATED FENCING REQUIRES VINYL COATED POSTS AND FITTINGS OVER GALVANIZED COATING
  - 9.) MINIMUM LINE POST SIZE IS 2-3/8". MINIMUM TERMINAL POST SIZE IS 2-7/8".

NOT TO SCALE

	RECOMMENDED:  DIVISION MANAGER DATE 1/21/14	<b>CITY OF MORENO VALLEY</b> PARKS AND COMMUNITY SERVICES DEPARTMENT <b>PARK PROJECTS          CHAIN LINK FENCE          AND GATES</b>	STANDARD PLAN <b>MVGF-641C-0</b>
	APPROVED:  PUBLIC WORKS DIRECTOR / CITY ENGINEER DATE 1/29/14		SHEET 3 OF 3



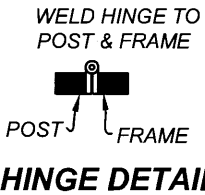

NTS

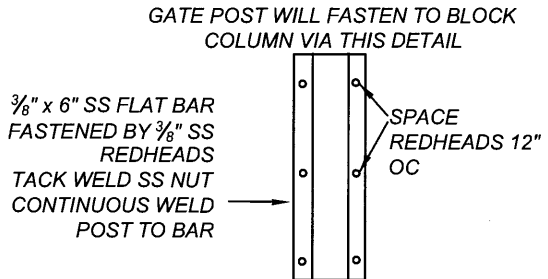

**GATE POST EMBEDDED DETAIL**

NTS

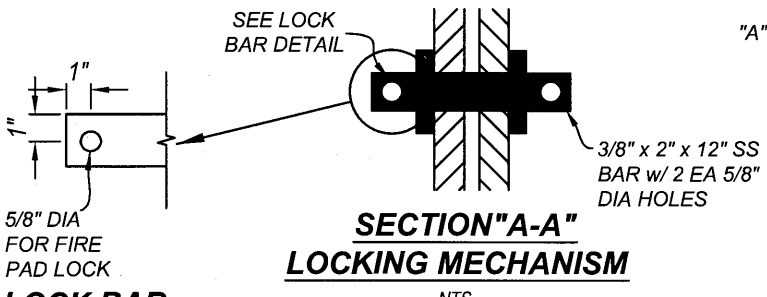
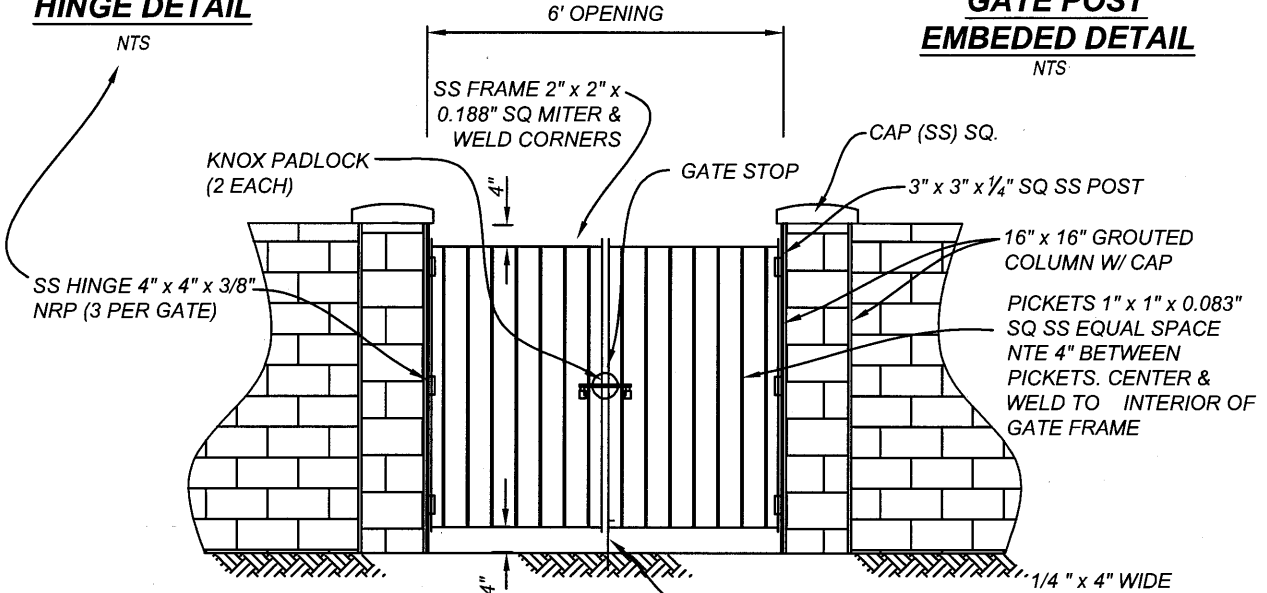

**LOCK BAR**

NTS

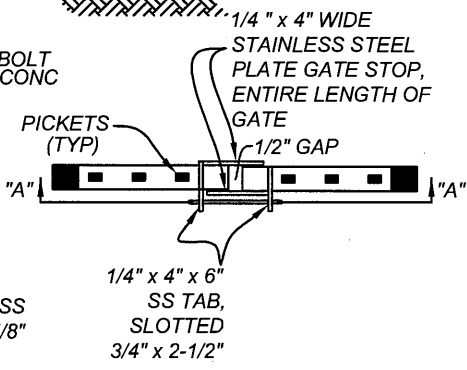

**TOP VIEW OF GATE**

NTS

**FIRE ACCESS GATE**

NTS

**NOTES:**

- 1.) ALL METAL IS TO BE STAINLESS STEEL No 304, SAND BLAST FINISH, NATURAL COLOR.
- 2.) COLUMN PER FENCE/WALL PLAN.

NOT TO SCALE

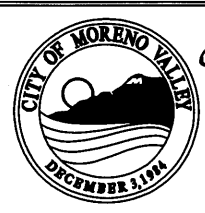

RECOMMENDED:  
*[Signature]* 8/21/18  
 DIVISION MANAGER DATE

APPROVED:  
*[Signature]* 9/14/18  
 PUBLIC WORKS DIRECTOR/ DATE  
 CITY ENGINEER

**CITY OF MORENO VALLEY**  
 PUBLIC WORKS DEPARTMENT - LAND DEVELOPMENT DIVISION

**FIRE ACCESS GATE**

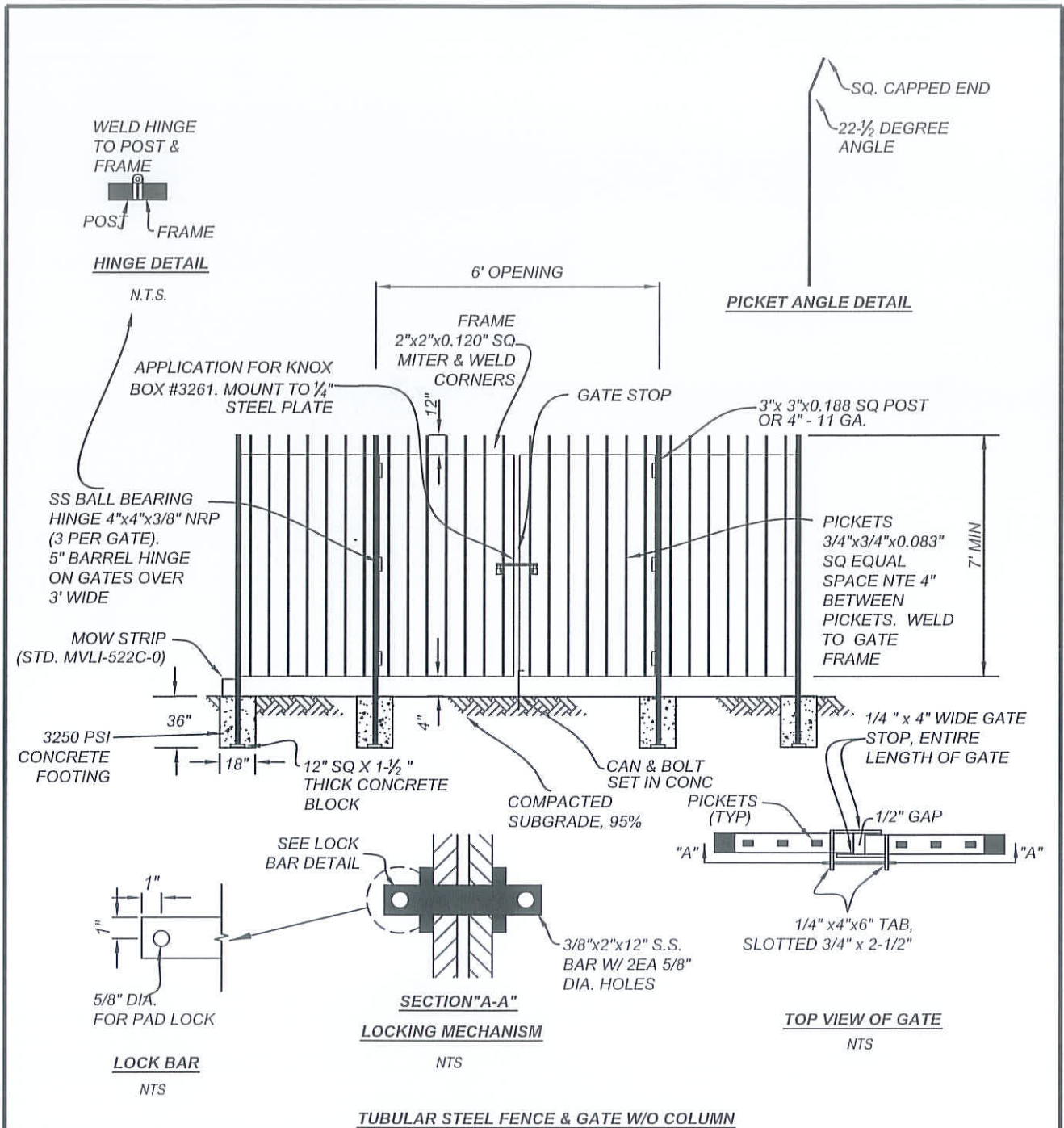

STANDARD PLAN  
**MVGF-642-0**  
 SHEET 1 OF 1



**NOTES:**

- 1.) ALL METAL IS TO BE STEEL AS INDICATED AND HOT DIPPED GALVANIZED.
- 2.) FINISH SHALL BE VITROCEM FOR METAL. COLOR PER SPECIFICATION.

NOT TO SCALE

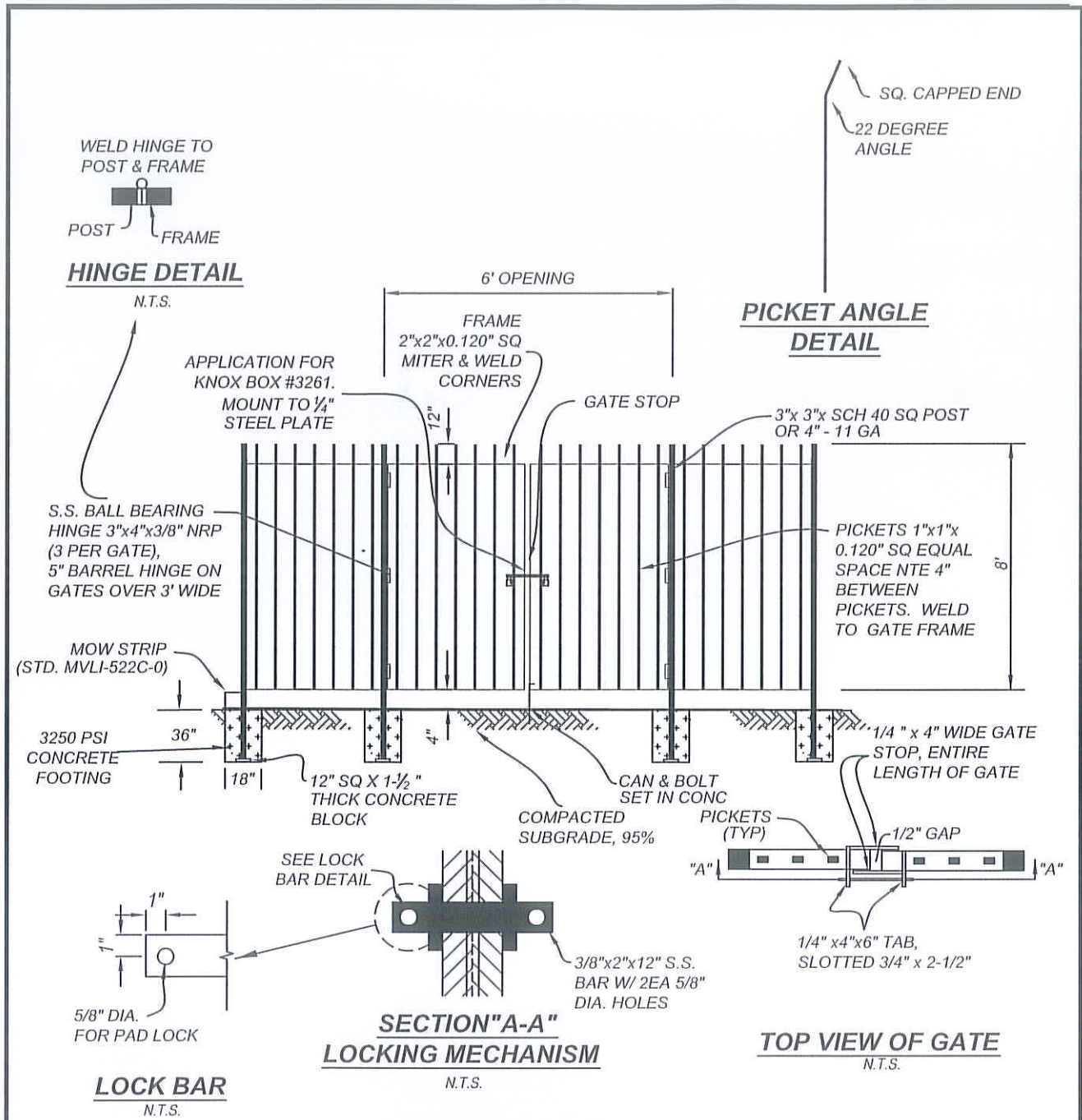

	RECOMMENDED:  DIVISION MANAGER DATE 11/21/14	<b>CITY OF MORENO VALLEY</b> PARKS AND COMMUNITY SERVICES DEPARTMENT	
	APPROVED:  PUBLIC WORKS DIRECTOR / DATE CITY ENGINEER	<b>STEEL FENCE &amp; GATE</b>	



**NOTES:**

- 1.) ALL METAL IS TO BE HOT DIPPED GALVANIZED STEEL.
- 2.) FINISH SHALL BE VITROCEM FOR METAL. COLOR PER SPECIFICATION.

NOT TO SCALE

	RECOMMENDED:  DIVISION MANAGER DATE 1/21/14	<b>CITY OF MORENO VALLEY</b> PARKS AND COMMUNITY SERVICES DEPARTMENT	
	APPROVED:  PUBLIC WORKS DIRECTOR / DATE CITY ENGINEER 1/29/14	<b>STEEL FENCE &amp; GATE FOR CELL SITES</b>	



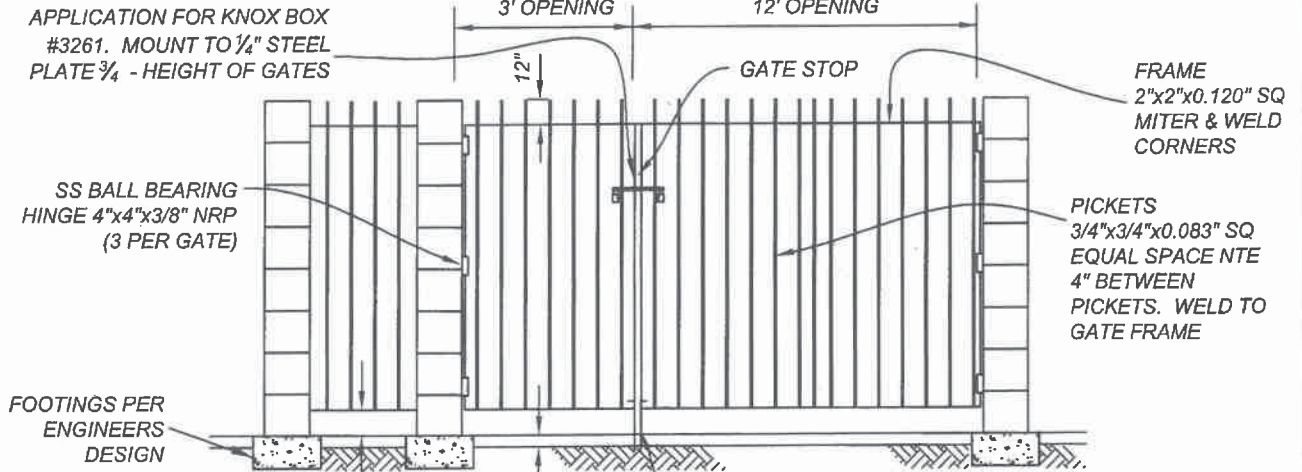

2" OR HEIGHT CAN BE INCREASED TO 4" IF A MOW STRIP IS USED

6" DRIVEWAY MIN

(2) CAN & BOLT SET IN CONC TO LOCK BOTTOM OF GATE

GATE POST WILL FASTEN TO BLOCK COLUMN VIA THIS DETAIL

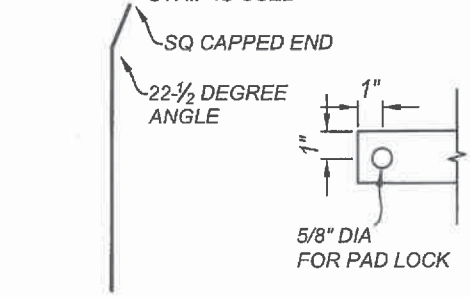

**PICKET ANGLE DETAIL**

**LOCK BAR**  
NTS

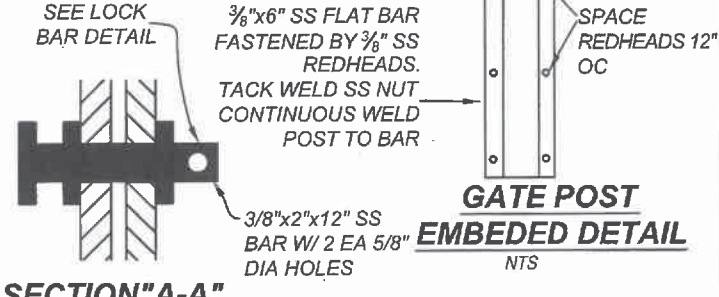

**SECTION "A-A" LOCKING MECHANISM**  
NTS

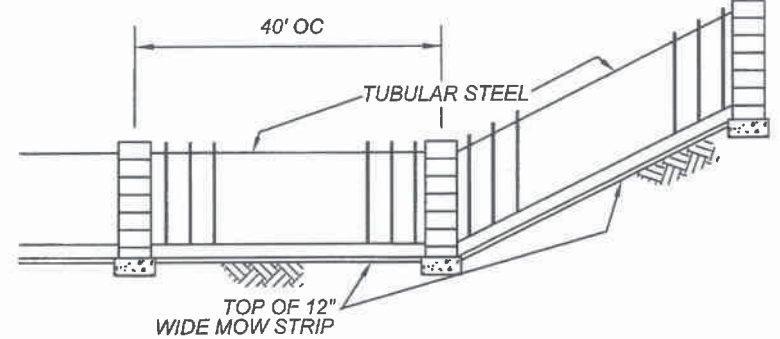

**ALTERNATE PLAN VIEW**  
NTS

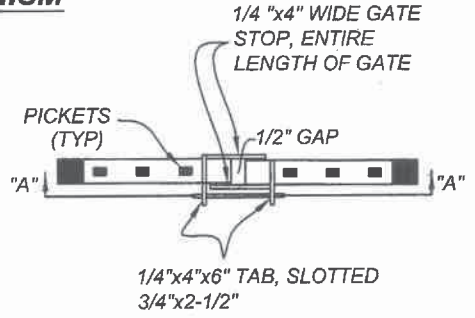

**TOP VIEW OF GATE**  
NTS

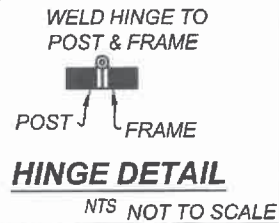

**HINGE DETAIL**  
NTS NOT TO SCALE

**NOTES:**

- 1.) ALL METAL IS TO BE STEEL AS INDICATED AND HOT DIPPED GALVANIZED.
- 2.) FINISH SHALL BE EPOXY PRIMER POLYURETHANE PAINT. COLOR PER SPECIFICATION.
- 3.) MOW STRIPE SHALL BE A MINIMUM 6" WIDE BY 6" THICK WITH ONE #4 REBAR.

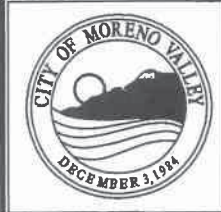

RECOMMENDED: *[Signature]* *[Signature]*  
 DIVISION MANAGER DATE  
 APPROVED: *[Signature]* 7/30/19  
 PUBLIC WORKS DIRECTOR / DATE  
 CITY ENGINEER

**CITY OF MORENO VALLEY**  
 PARKS AND COMMUNITY SERVICES DEPARTMENT

**MODIFIED EXTENDED  
 DETENTION BASIN FENCE  
 AND GATE DETAIL GUIDE**

STANDARD PLAN  
**MVGF-644-0**  
 SHEET 1 OF 1



**GENERAL NOTES:**



1. ALL WORK SHALL CONFORM TO THE LATEST EDITION OF THE CALIFORNIA BUILDING CODE (CBC) AS ADOPTED BY THE CITY OF MORENO VALLEY.
2. THE CONCRETE BLOCK SHALL BE DECORATIVE AND REQUIRE APPROVAL FROM THE PLANNING DIVISION.
3. CONCRETE BLOCK MASONRY SHALL COMPLY WITH THE FOLLOWING:
  - A. CONCRETE MASONRY SHALL CONFORM TO ASTM C-90, GRADE - N.
  - B. MORTAR: TYPE M OR TYPE S.
  - C. GROUT ALL CELLS W/2000 PSI CONCRETE.
4. THE ULTIMATE COMPRESSIVE STRENGTH REQUIRED FOR FOUNDATION CONCRETE SHALL BE OF 2000 PSI.
5. ALL REINFORCING STEEL SHALL BE INTERMEDIATE GRADE ASTM A615 - 40.
6. INSTALL A RETAINING WALL DRAINAGE SYSTEM AS FOLLOWS  
 FOR WALLS OVER 4'-0" HIGH  
 PROVIDE 1 CF/FT OF CLEAN COURSE GRAVEL WITH  
 4" DIA PERFORATED PVC. PIPE W/1% GRADIENT TO DRAIN OR  
 OMIT HEAD JOINTS IN FIRST COURSE.
7. INSPECTION SHALL BE OF THE FOLLOWING STEPS:
  - 1ST. FOUNDATION TRENCH WITH SECURED REINFORCING STEEL.
  - 2ND. BLOCK WALL WITH REINFORCING STEEL BEFORE GROUT.
  - 3RD. GROUTED WALL AND DRAINAGE SYSTEM.  
 (NO BACK FILL IS ALLOWED) BEFORE DRAIN SYSTEM INSPECTION.
  - 4TH. BACK FILL AND FINAL.
8. SITE PLAN SHALL BE SUBMITTED FOR REVIEW BEFORE THE WALL PERMIT CAN BE ISSUED. THE HEIGHT OF PROPOSED WALL SHALL BE DETERMINED ON THE SITE PLAN.
9. WALLS SHALL NOT OBSTRUCT OR CONCENTRATE DRAINAGE.
10. ALL FOOTINGS SHALL BE A MINIMUM 5' TO A DAYLIGHT SLOPE.
11. WALLS WITH FENCES OR OTHER NEARBY SURCHARGES REQUIRE SPECIAL ANALYSIS USE ORCO WALL SYSTEM ICBO ER 5020 AS AN OPTION.
12. WALLS OVER 6' HIGH REQUIRE SPECIAL DESIGN AND APPROVAL.
13. WALLS ARE DESIGNED WITH 6" SOIL OVER TOE.
14. ALL WALL CONSTRUCTION SHALL BE PER BUILDING AND SAFETY PERMIT.

**WALL CONSTRUCTION NOTES**

1. ALL FOOTINGS TO BE PLACED AGAINST UNDISTURBED SOIL SOIL BEARING VALUE BASED ON 1000 PSF.
2. ALL REINFORCING STEEL SHALL BE GRADE 40 WITH A MINIMUM OF 24" LAP.
3. ALL REINFORCING STEEL SHALL MAINTAIN 3" CLEAR TO EARTH.
4. MAXIMUM CONTROL JOINTS SHALL BE AT 20' INTERVALS.

NOT TO SCALE



RECOMMENDED:  
 1-17  
 DIVISION MANAGER DATE  
 APPROVED:  
 1/20/17  
 PUBLIC WORKS DIRECTOR / DATE  
 CITY ENGINEER

**CITY OF MORENO VALLEY**  
 FINANCIAL & MANAGEMENT SERVICES DEPARTMENT - ELECTRIC UTILITY DIVISION

**RETAINING WALL NOTES  
 FOR ELECTRICAL FACILITIES**

STANDARD PLAN  
**MVGF-650A-0**  
 SHEET 1 OF 2

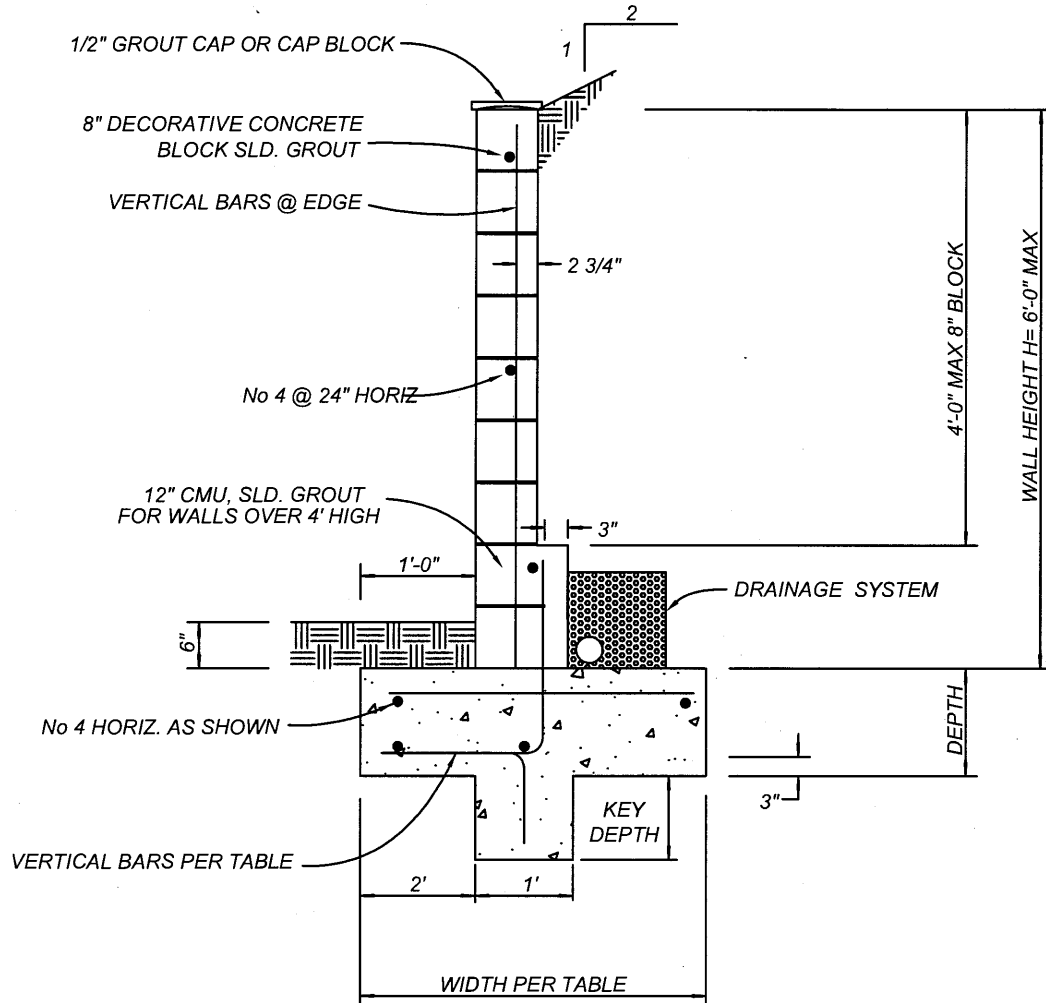

WALL WITH 2:1 BACKFILL SLOPE				
WALL HEIGHT	FOOTING WIDTH	VERTICAL BARS	FOOTING DEPTH	KEY WIDTH/DEPTH
3'-0"	1'-10"	No 4 @ 32" OC	12"	6" x 6"
4'-0"	2'-9"	No 4 @ 32" OC	12"	12" x 12"
4'-8"	3'-3"	No 4 @ 24" OC	14"	12" x 14"
6'-0"	4'-6"	No 4 @ 24" OC	14"	12" x 22"

WALL WITH LEVEL BACKFILL				
WALL HEIGHT	FOOTING WIDTH	VERTICAL BARS	FOOTING DEPTH	KEY WIDTH/DEPTH
3'-0"	1'-9"	No 4 @ 32" OC	12"	6" x 6"
4'-0"	2'-9"	No 4 @ 32" OC	12"	6" x 8"
4'-8"	3'-0"	No 4 @ 24" OC	14"	12" x 12"
6'-0"	3'-9"	No 4 @ 24" OC	14"	12" x 20"

NOT TO SCALE

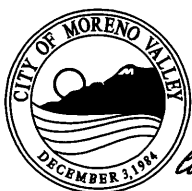

RECOMMENDED:

*[Signature]*  
DIVISION MANAGER

1.9.17  
DATE

APPROVED:

*[Signature]*  
PUBLIC WORKS DIRECTOR / DATE  
CITY ENGINEER

# CITY OF MORENO VALLEY

FINANCIAL & MANAGEMENT SERVICES DEPARTMENT - ELECTRIC UTILITY DIVISION

## RETAINING WALL SECTIONS FOR ELECTRICAL FACILITIES

STANDARD PLAN

**MVGF-650B-0**

SHEET 2 OF 2

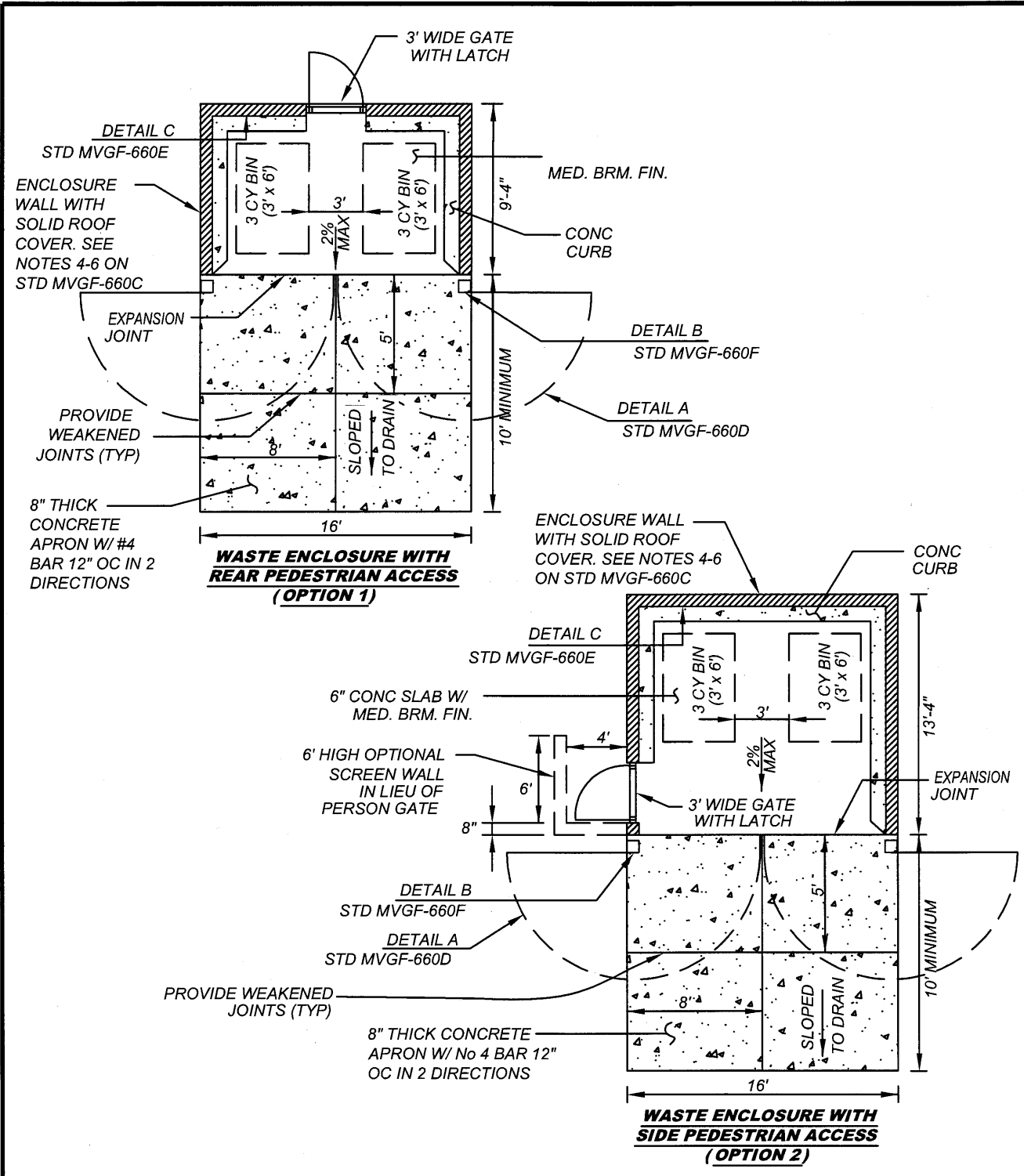

**FOR MORENO VALLEY PARKS ONLY**

NOT TO SCALE

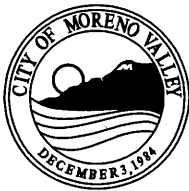
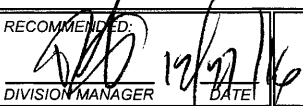
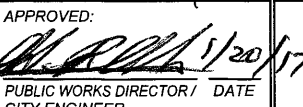
	RECOMMENDED:  DIVISION MANAGER DATE	<b>CITY OF MORENO VALLEY</b> PARKS AND COMMUNITY SERVICES DEPARTMENT	STANDARD PLAN <b>MVGF-660A-1</b>
	APPROVED:  PUBLIC WORKS DIRECTOR / DATE CITY ENGINEER		<b>DUAL BIN COVERED WASTE ENCLOSURE FOR PARKS CASE A</b>

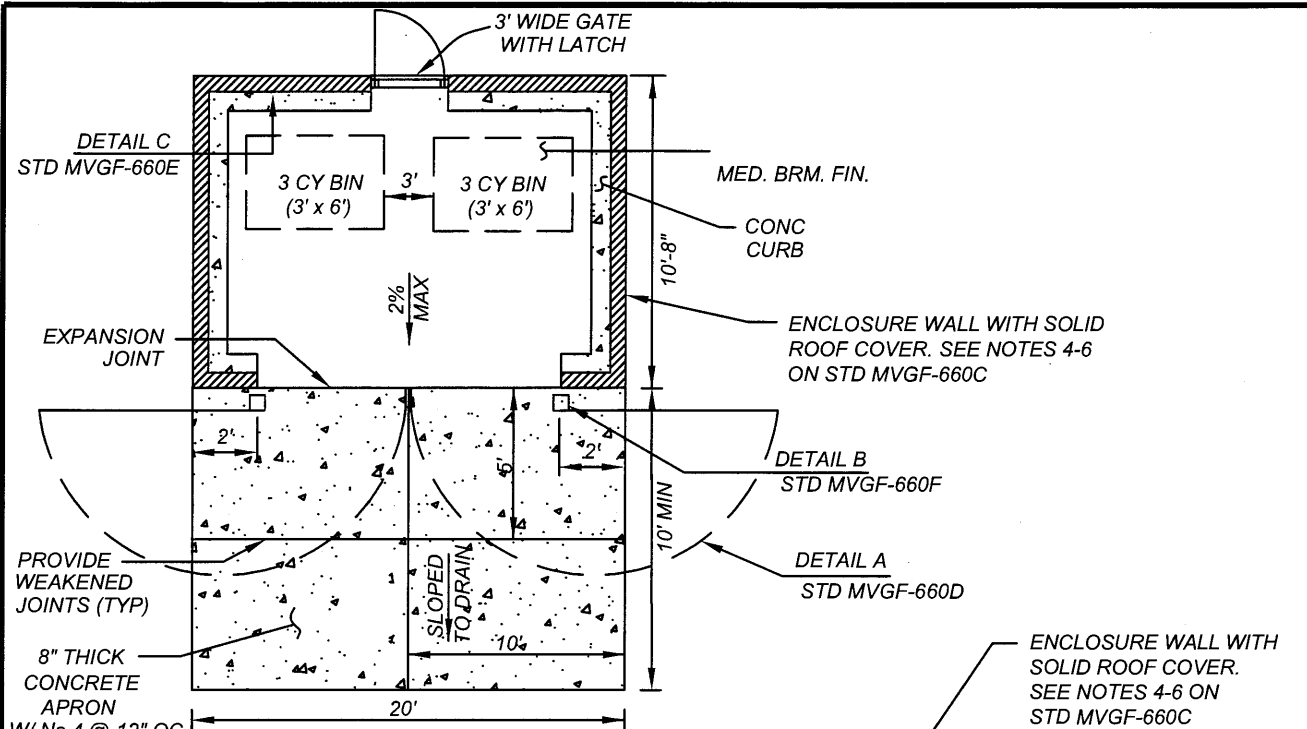

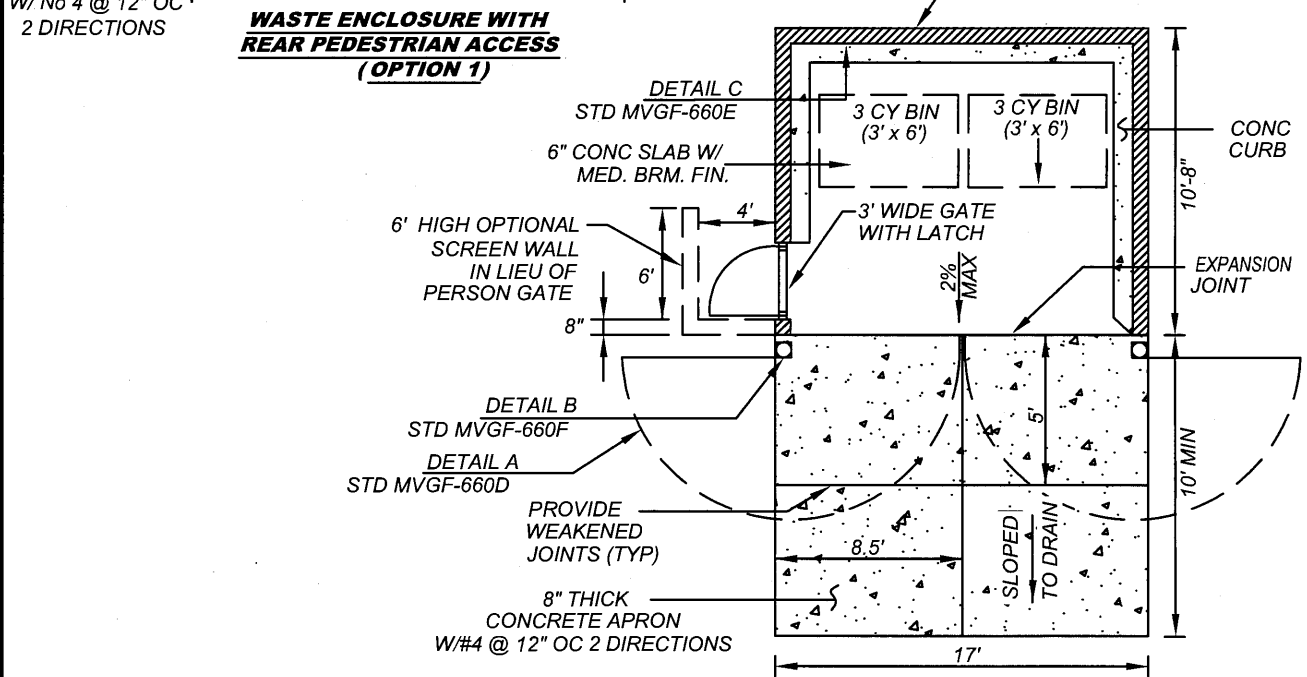

**WASTE ENCLOSURE WITH REAR PEDESTRIAN ACCESS (OPTION 1)**



**WASTE ENCLOSURE WITH SIDE PEDESTRIAN ACCESS (OPTION 2)**

**FOR MORENO VALLEY PARKS ONLY**

NOT TO SCALE

	RECOMMENDED:  DIVISION MANAGER DATE: 12/1/17	<b>CITY OF MORENO VALLEY</b> PARKS AND COMMUNITY SERVICES DEPARTMENT <b>DUAL BIN COVERED WASTE ENCLOSURE FOR PARKS CASE B</b>	STANDARD PLAN <b>MVGF-660B-1</b>
	APPROVED:  PUBLIC WORKS DIRECTOR / DATE CITY ENGINEER		SHEET 2 OF 6





**NOTES**

1. THIS STANDARD IS FOR WASTE ENCLOSURES FOR USE IN MORENO VALLEY PARKS ONLY.
2. LOCATION OF THE WASTE ENCLOSURE SHOULD BE APPROVED BY PARKS AND COMMUNITY SERVICES DIVISION.
3. PROVIDE A MINIMUM OF 3' ON 3 SIDES OF THE ENCLOSURE WALLS TO ACCOMMODATE CLIMBING VINES AND SCREENING SHRUBS.
4. CONCRETE SHALL BE CLASS 560-C-3250.
5. ENCLOSURE SHALL HAVE A FULLY COVERED SOLID ROOF. HEIGHT, ARCHITECTURAL STYLE, ETC. WILL BE AT THE DISCRETION OF THE DEVELOPER, AS APPROVED BY PARKS AND COMMUNITY SERVICES DIVISION.
6. THE ENCLOSURE ROOF SHALL SLOPE TOWARD A LANDSCAPED AREA, WHERE POSSIBLE.
7. ENCLOSURE ROOF SHALL SLOPE AT 1% MINIMUM.
8. ONE BIN SHALL BE FOR REGULAR TRASH AND ONE BIN SHALL BE FOR RECYCLABLES.
9. THIS STANDARD DOES NOT CONSTITUTE CONSTRUCTION DRAWINGS. A SEPARATE ENGINEERED SUBMITTAL TO THE CITY'S BUILDING AND SAFETY DIVISION IS REQUIRED.

**FOR MORENO VALLEY PARKS ONLY**

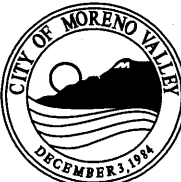
NOT TO SCALE

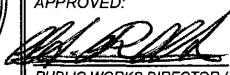
	RECOMMENDED: 	<b>CITY OF MORENO VALLEY</b> PARKS AND COMMUNITY SERVICES DEPARTMENT	STANDARD PLAN <b>MVGF-660C-1</b>
	DIVISION MANAGER 		
APPROVED: 		PUBLIC WORKS DIRECTOR / DATE CITY ENGINEER	SHEET 3 OF 6

**DETAIL A  
ELEVATION AT GATE**

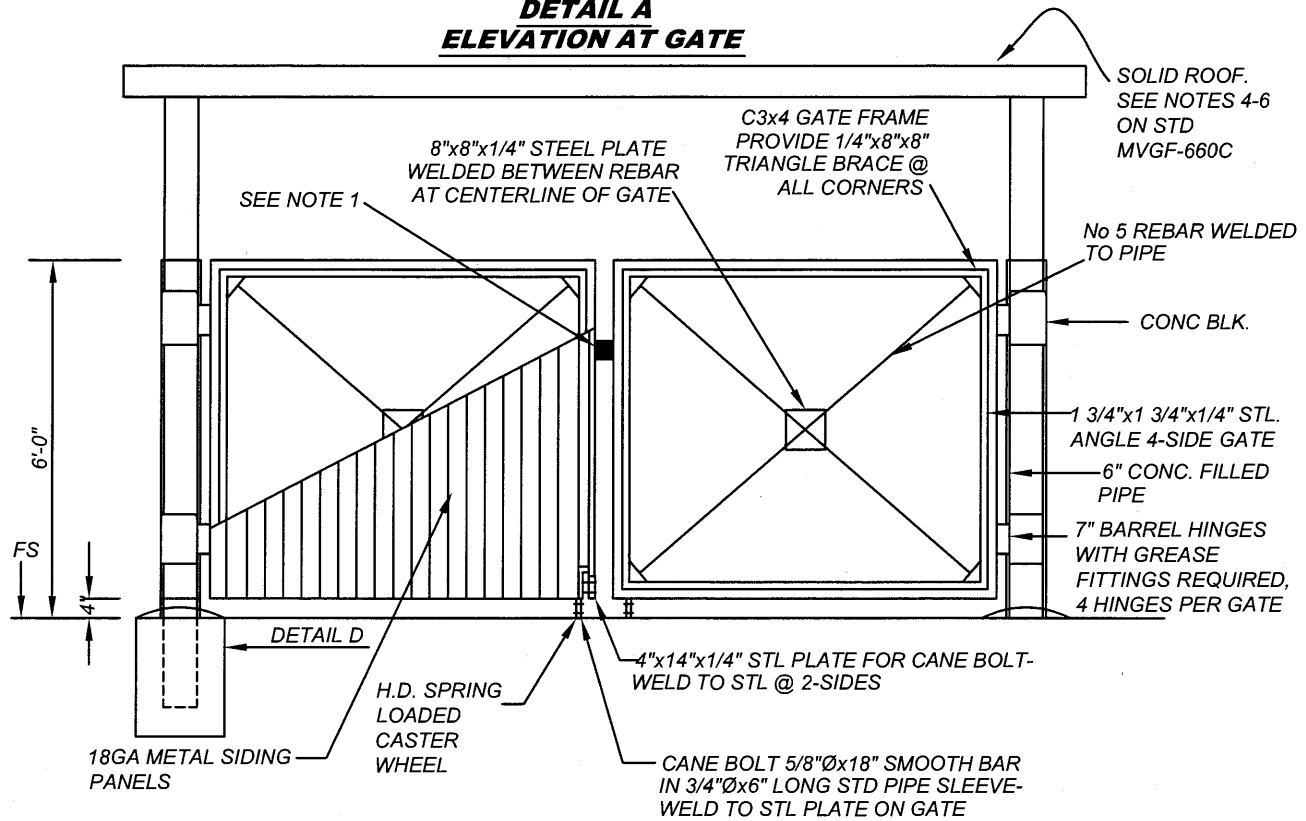

6" SQ STEEL SCH 40 GALVANIZED PIPE FILL IN CONC ROUND AND TROWEL EXPOSED CONC

1/2" PREMOLDED JOINT FILLER W/SEALANT

6" CONC SLAB

18" CONC FOOTING FOR PIPE BOLLARD

10" x 10" PAVING STONE

**DETAIL D  
PIPE FOOTING**



**NOTES:**

- 1.) PROVIDE GATE LATCH. 3/8" Ø PAD LOCKABLE SS TYPE 304, FLUSH MOUNT GATE LATCH (BOLT TO FRAME WITH VANDAL PROOF NUTS & BOLTS).
- 2.) CONTRACTOR SHALL PROVIDE SHOP DRAWINGS FOR GATE ASSEMBLY.
- 3.) PAINT ALL STEEL, COLOR TO MATCH BLDG 1 COAT EPOXY PRIMER, 2 COATS POLYURETHANE PAINT.
- 4.) GATES SHOULD BE ABLE TO OPEN MORE THAN 90 DEGREES AND SHOULD BE EQUIPPED TO PREVENT ACCIDENTAL SWINGING, WHICH CAN RESULT IN INJURY TO PERSONS OR EQUIPMENT.
- 5.) HARDWARE SHALL BE OF SUFFICIENT STRENGTH TO ACCOMMODATE REPETITIVE SWINGING.
- 6.) WHEN USED, LOCKS SHALL BE STANDARD, A MINIMUM 2" BRASS RESETTABLE COMBINATION LOCK (4 DIGIT DIALING ON BOTTOM OF LOCK). LOCK COMBINATIONS WILL BE SET BY ENCLOSURE USER AND THAT INFORMATION WILL BE GIVEN TO THE FRANCHISED HAULER.
- 7.) HOT DIP GALVANIZED FRAME AND PANELS.

**FOR MORENO VALLEY PARKS ONLY**

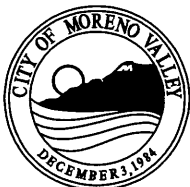
NOT TO SCALE

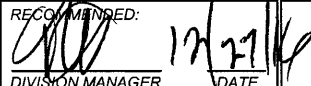

RECOMMENDED:  
  
 DIVISION MANAGER DATE  
 APPROVED:  
  
 PUBLIC WORKS DIRECTOR/ DATE  
 CITY ENGINEER

**CITY OF MORENO VALLEY**

PARKS AND COMMUNITY SERVICES DEPARTMENT

**WASTE ENCLOSURE GATE  
FOR PARKS**

STANDARD PLAN  
**MVGF-660D-1**  
 SHEET 4 OF 6

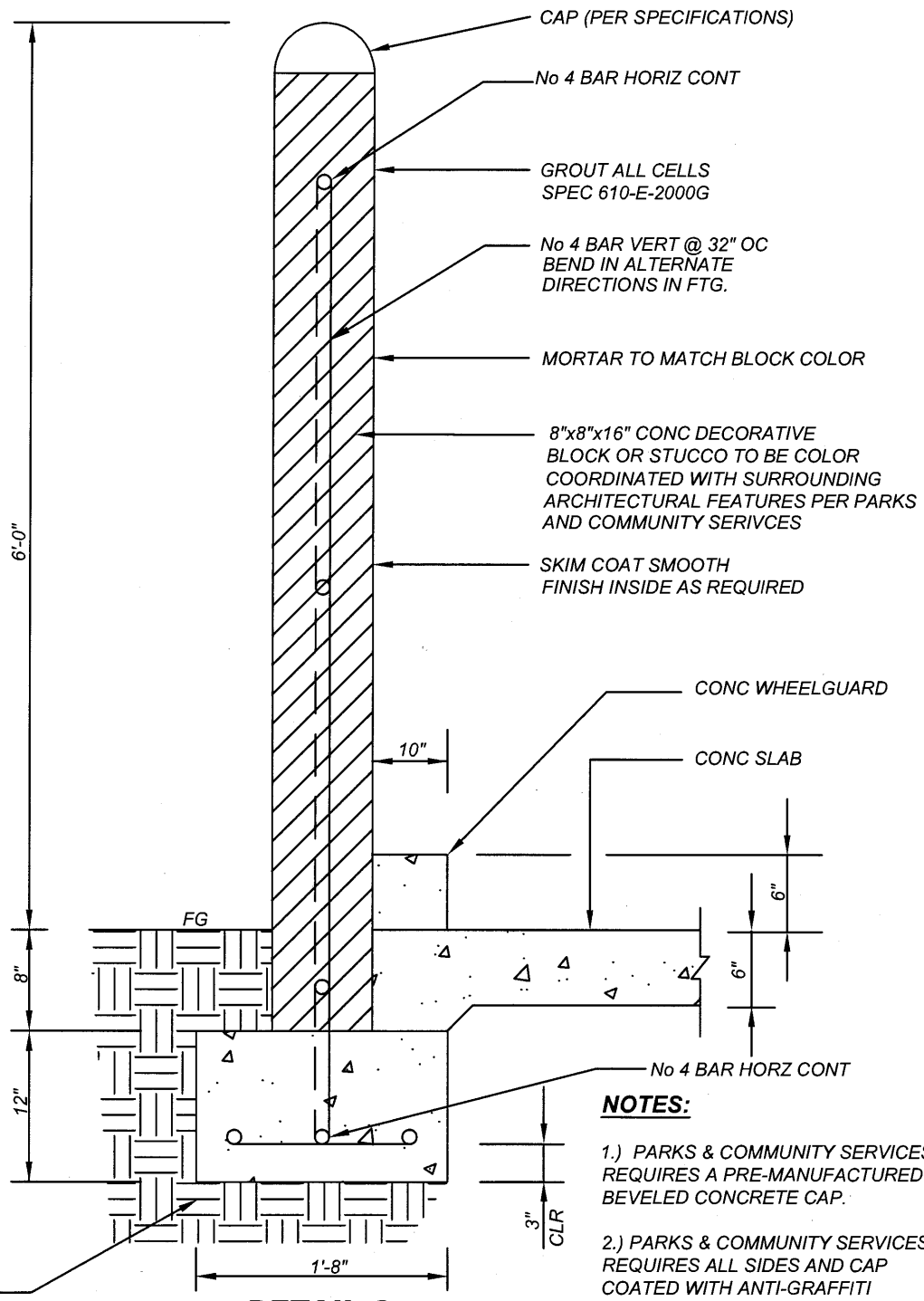



**NOTES:**

- 1.) PARKS & COMMUNITY SERVICES REQUIRES A PRE-MANUFACTURED BEVELED CONCRETE CAP.
- 2.) PARKS & COMMUNITY SERVICES REQUIRES ALL SIDES AND CAP COATED WITH ANTI-GRAFFITI COATING PER SPECIFICATIONS.
- 3.) FLOOR MUST BE SEALED WITH APPROVED SEALER.

NOT TO SCALE

**DETAIL C**

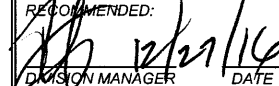
**FOR MORENO VALLEY PARKS ONLY**

	RECOMMENDED:  DIVISION MANAGER      DATE	<h2 style="margin: 0;">CITY OF MORENO VALLEY</h2> <p style="margin: 0;">PARKS AND COMMUNITY SERVICES DEPARTMENT</p>	
	APPROVED:  PUBLIC WORKS DIRECTOR / DATE CITY ENGINEER	<h3 style="margin: 0;">WASTE ENCLOSURE WALL &amp; FOOTING FOR PARKS</h3>	

**NOTES:**

- 1.) STEEL SLEEVE SIZE SHOULD BE DETERMINED BY EASE OF SWING ACTION, WHILE MAINTAINING A SECURE FIT.
- 2.) PAINT EPOXY PRIMER PAINT - 2 COATS WITH A DRY FILM THICKNESS OF 10 MILS.
- 3.) PAINT ALL STEEL COLOR TO MATCH BUILDING WITH 2 COATS POLYURETHANE. MINIMUM DRY FILM THICKNESS OF 4 MILS.

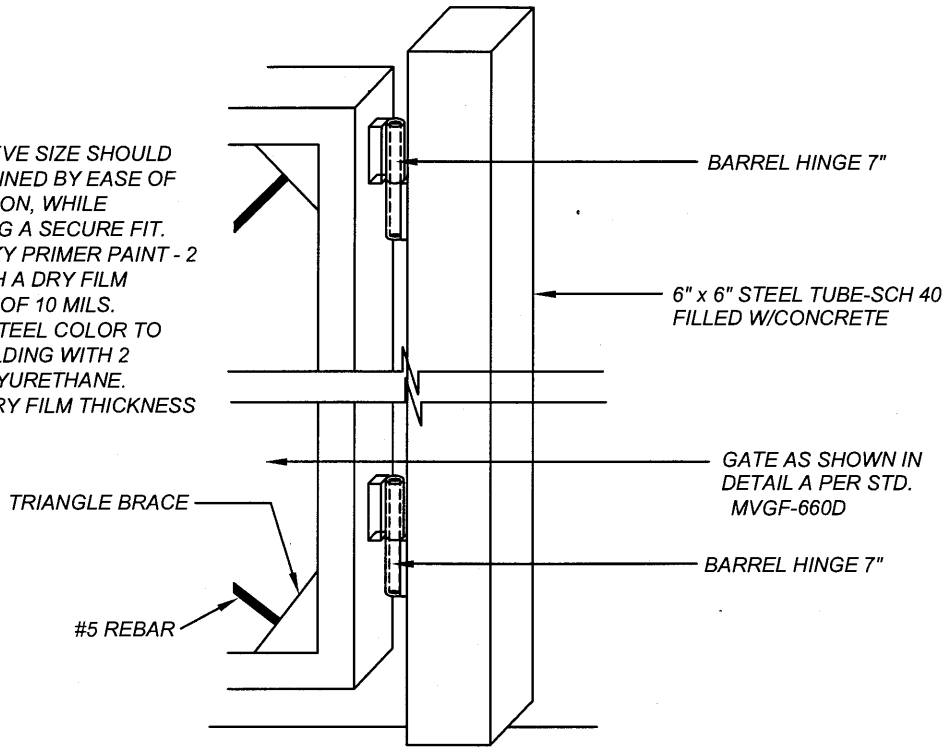

**ELEVATION**

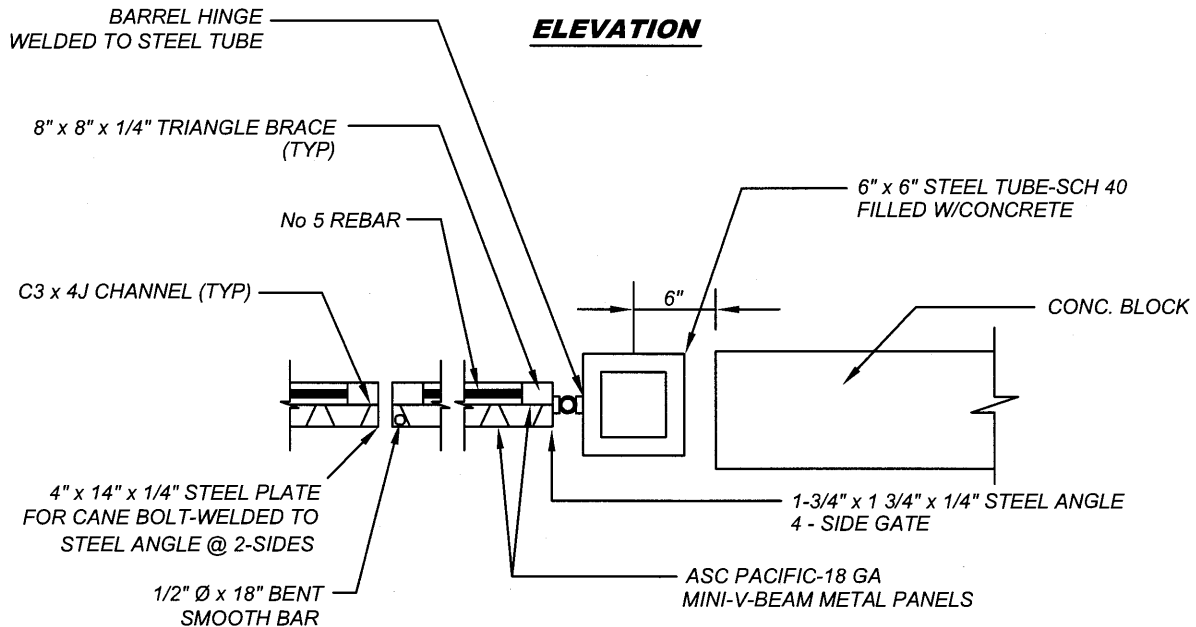

**DETAIL B**

NOTE:  
ALL STEEL TO BE HOT DIPPED GALVANIZED.  
NOT TO SCALE

**FOR MORENO VALLEY PARKS ONLY**

	RECOMMENDED:  DIVISION MANAGER      DATE	<h2 style="margin: 0;">CITY OF MORENO VALLEY</h2> <p style="margin: 0;">PARKS AND COMMUNITY SERVICES DEPARTMENT</p>
	APPROVED:  PUBLIC WORKS DIRECTOR / DATE CITY ENGINEER	<h3 style="margin: 0;">WASTE ENCLOSURE GATE HINGE FOR PARKS</h3>



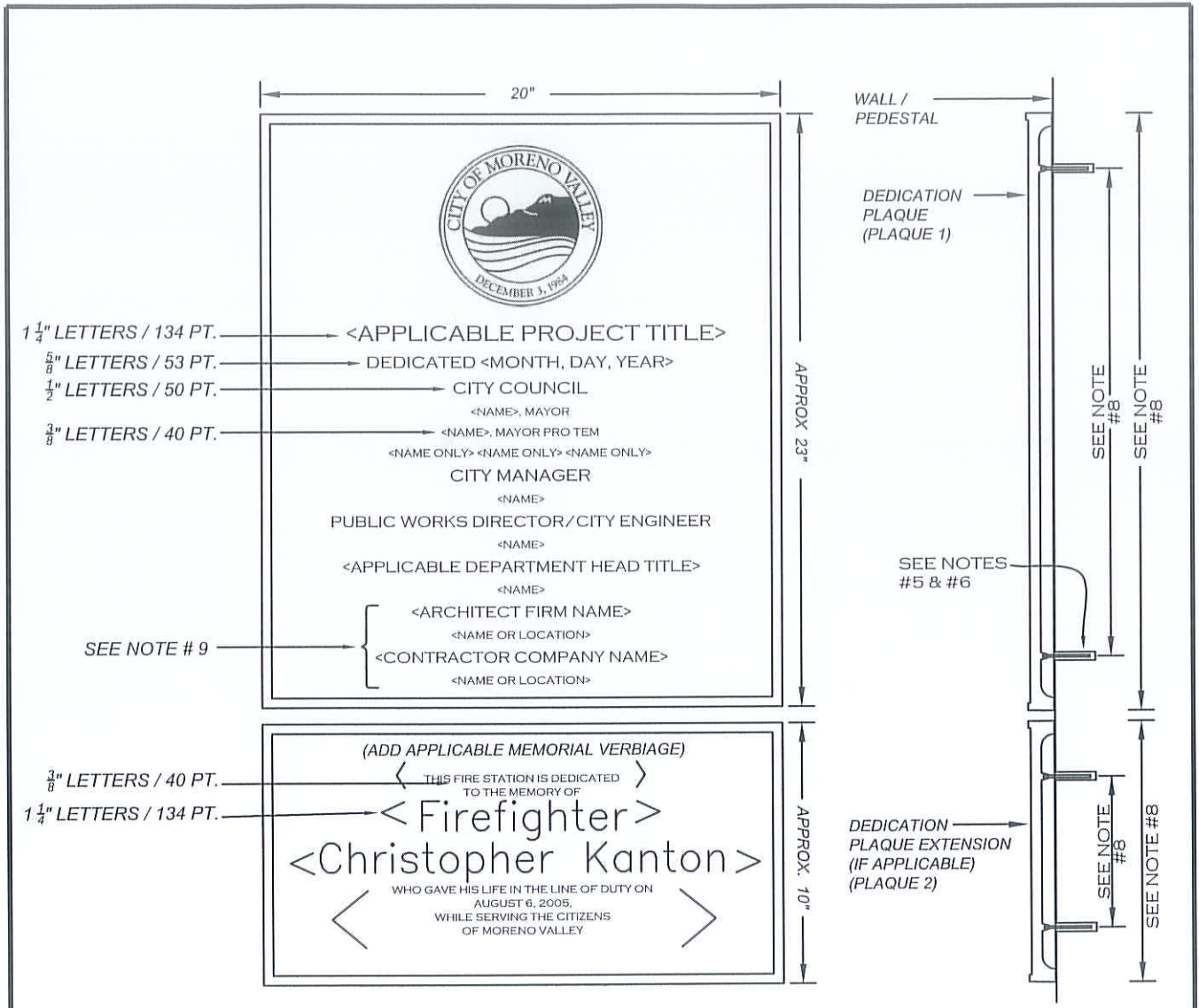



PLAQUE LAYOUT DETAIL

PLAQUE MOUNTING DETAIL

**NOTES:**

1. PLAQUE SHALL HAVE A SATIN FINISH WITH BROWN BACKGROUND AND LEATHERETTE TEXTURE AND PROTECTED WITH A CLEAR ACRYLIC COATING (THIS INCLUDES THE CITY SEAL).
2. THE TYPE/STYLES USED FOR THESE PLAQUES ARE TIMES BOLD AND COPPERPLATE.
3. THE LOCATION FOR THE PLAQUE TO BE DETERMINED BY APPLICABLE DEPARTMENT.
4. PLAQUE EXTENSION (BELOW MAIN PLAQUE) IS TO BE USED WHEN APPLICABLE.
5. MOUNTING STUDS MUST BE EMBEDDED A MINIMUM OF 1 1/2".
6. MOUNTING STUDS SET IN WALL / PEDESTAL WITH SILICONE.
7. SEE STANDARD MVGF-670B-0 FOR PLAQUE DIMENSIONS AND MAY BE MODIFIED ON A CASE BY CASE BASIS.
8. DIMENSIONS AS RECOMMENDED BY MANUFACTURER.
9. THE NAME OF THE ARCHITECT OR CONTRACTOR (OR BOTH) SHALL ONLY BE SHOWN ON THE PLAQUE IF THE ARCHITECT OR CONTRACTOR (OR BOTH) AGREES TO PAY FOR THE MATERIALS AND INSTALLATION COSTS OF THE PLAQUE.

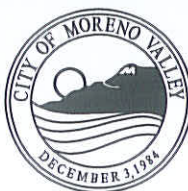
NOT TO SCALE

	RECOMMENDED:  DIVISION MANAGER DATE: 1/21/14	<h2 style="margin: 0;">CITY OF MORENO VALLEY</h2> <p style="margin: 0;">PUBLIC WORKS DEPARTMENT - CAPITAL PROJECTS DIVISION</p>	STANDARD PLAN
	APPROVED:  PUBLIC WORKS DIRECTOR / CITY ENGINEER DATE: 1/29/14	<h3 style="margin: 0;">FACILITY DEDICATION PLAQUE</h3>	<h3 style="margin: 0;">MVGF-670A-0</h3>

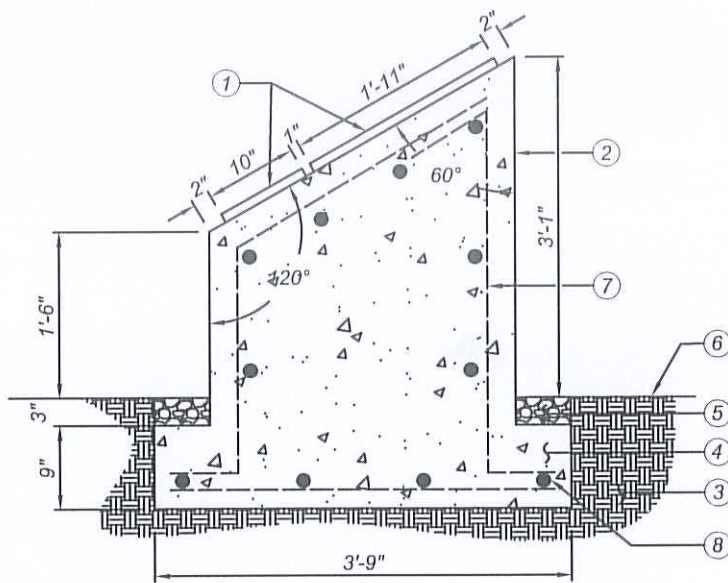

**SIDE ELEVATION**

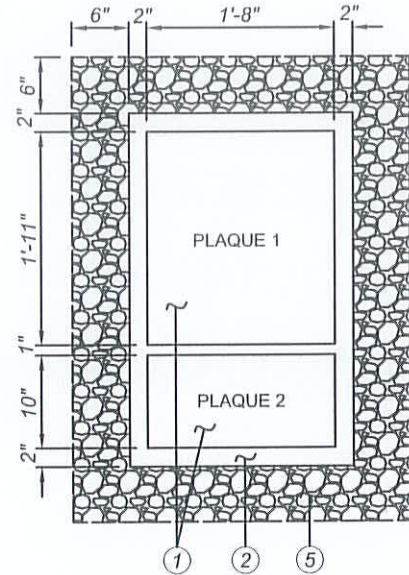

**PLAN VIEW**

**LEGEND:**

- ① DEDICATION PLAQUE
- ② FINISH TYPICALLY TO BE CONCRETE.
- ③ BASE MATERIAL & COMPACTED SUB-GRADE.
- ④ STRUCTURAL FOOTING - 3'-9" x 3'-0".
- ⑤ ROCK MULCH - 1"-2" BUFF COLOR MEXICAN PEBBLE.
- ⑥ ALUMINUM EDGE - BLACK ANODIZED
- ⑦ No 4 @ 12" OC EA WAY, TYP.
- ⑧ 4- No 4 EA WAY, TYP.

**NOTES:**

- 1. ADJUST SURROUNDING IRRIGATION ACCORDINGLY, IF PLACED IN EXISTING LANDSCAPED AREA.
- 2. SEAL ALL CONCRETE WITH APPROPRIATE SEALER MATERIAL.
- 3. 1/8" RADIUS AT ALL CONCRETE EDGES/CORNERS.

NOT TO SCALE

	RECOMMENDED:  DIVISION MANAGER / DATE 1/21/14	<h2 style="margin: 0;">CITY OF MORENO VALLEY</h2> <p style="margin: 0;">PUBLIC WORKS DEPARTMENT - CAPITAL PROJECTS DIVISION</p>	STANDARD PLAN <b>MVGF-670B-0</b>
	APPROVED:  PUBLIC WORKS DIRECTOR / DATE 1/29/14 CITY ENGINEER	<h3 style="margin: 0;">DEDICATION PLAQUE PEDESTAL</h3>	SHEET 2 OF 2

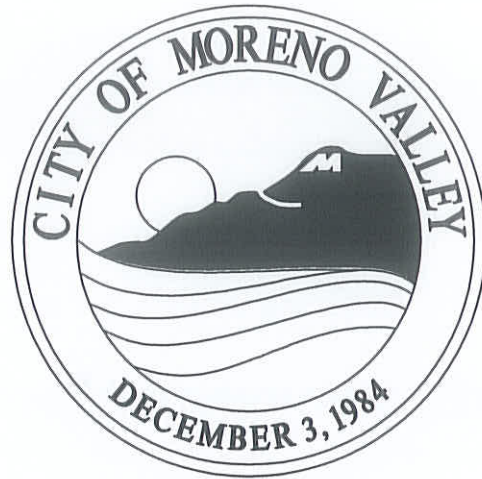

# **CITY OF MORENO VALLEY STANDARD PLANS**

## **SECTION 7**

### **ELECTRIC UTILITY**

# City of Moreno Valley

## Standard Plans Index - 2022 Edition

---

### **SECTION 6:      General Facilities (Continued)**

#### Building Facilities

<i>MVGF-670A-0</i>	<i>Facility Dedication Plaque</i>
<i>MVGF-670B-0</i>	<i>Dedication Plaque Pedestal</i>

### **SECTION 7:      Electric Utility**

<i>MVEU-700-0</i>	<i>Title Sheet Base (for Electric Utility Division)</i>
<i>MVEU-701-0</i>	<i>Conduits &amp; Cable Call-Outs</i>
<i>MVEU-702-0</i>	<i>Structure &amp; Equipment Symbols</i>
<i>MVEU-703-1</i>	<i>Equipment Legends</i>
<i>MVEU-704-0</i>	<i>Vicinity &amp; Project Map</i>
<i>MVEU-705-0</i>	<i>Approved Status Stamp</i>
<i>MVEU-706A-0</i>	<i>Designer Declaration</i>
<i>MVEU-706B-0</i>	<i>Engineer's Notice to Contractor</i>
<i>MVEU-707A-0</i>	<i>Statement of Plan Review</i>
<i>MVEU-707B-0</i>	<i>Statement of Plan Review</i>
<i>MVEU-708-0</i>	<i>Design Information</i>
<i>MVEU-709-1</i>	<i>Dry Utilities Trench Section</i>
<i>MVEU-710A-0</i>	<i>Electrical Singleline Diagram Residential</i>
<i>MVEU-710B-0</i>	<i>Electrical Singleline Diagram Backbone</i>
<i>MVEU-711A-0</i>	<i>48" x 54" Pad for Pad Mounted &amp; Mini Pad Mounted Transformer</i>
<i>MVEU-711B-0</i>	<i>Mini Pad Mounted Transformer Cable Connections</i>
<i>MVEU-712-1</i>	<i>66" x 72" Pad for 75kVA - 300kVA Pad Mounted Transformers</i>
<i>MVEU-713-0</i>	<i>72" x 94" Pad for 75kVA - 500kVA Pad Mounted Transformers</i>
<i>MVEU-714-0</i>	<i>6' x 8'-6" Pad with Box for 75kVA-500kVA Pad Mounted Transformers</i>
<i>MVEU-715-0</i>	<i>8' x 10' Pad with Box for 750kVA-1000kVA Pad Mounted Transformers</i>
<i>MVEU-716-0</i>	<i>10' x 12' Pad with Box for 1500kVA - 2500kVA Pad Mounted Transformers</i>
<i>MVEU-717-0</i>	<i>72" x 94" Pad for Pad-Mounted Capacitors</i>
<i>MVEU-718-0</i>	<i>Pad Mounted Switch Enclosure Detail 5' x 10'-6" x 7'</i>
<i>MVEU-719-0</i>	<i>17" x 30" x 24" Pull Box for Service Connection</i>
<i>MVEU-720-0</i>	<i>10.5" x 17" x 24" Pull Box for Street Light Connection</i>
<i>MVEU-721-0</i>	<i>Precast Concrete Parkway Enclosure 2' x 3' x 5' and 3' x 5' x 5'</i>
<i>MVEU-722-0</i>	<i>Protective Barriers for Equipment and Structures Subject to Traffic Locations</i>
<i>MVEU-723-0</i>	<i>Retaining Walls for Pad-Mounted Switches and Transformers</i>
<i>MVEU-724A-2</i>	<i>Joint Trench Details for Conduit Installations</i>
<i>MVEU-724B-2</i>	<i>Electric Only Trench Details for Conduit Installations</i>
<i>MVEU-725-0</i>	<i>Surface Operable Enclosure 5' x 8.5' x 5'</i>
<i>MVEU-726-0</i>	<i>Vault 6' x 12' x 7'</i>
<i>MVEU-727A-0</i>	<i>Conduit Bank Requirements - Installation in a Bore</i>



# City of Moreno Valley

## Standard Plans Index - 2022 Edition

---

### **SECTION 7: Electric Utility (Continued)**

<i>MVEU-727B-0</i>	<i>Conduit Bank Requirements</i>
<i>MVEU-728A-0</i>	<i>Manhole 5' x 10.5' x 7'</i>
<i>MVEU-728B-0</i>	<i>Manhole 4' x 6.5' x 7'</i>
<i>MVEU-729A-0</i>	<i>Project Sign- Electrical Distribution Project</i>
<i>MVEU-729B-0</i>	<i>Project Completion Sign- Electrical Distribution Project</i>
<i>MVEU-730A-0</i>	<i>Vault 7' x 14' x 8'</i>
<i>MVEU-730B-0</i>	<i>Vault 7' x 18' x 8'</i>
<i>MVEU-730C-0</i>	<i>4' x 6' Pad w/ 2.5' x 4' Box for PMH-4 or PMH-5 Switchgear</i>
<i>MVEU-731-0</i>	<i>Support for Conduits on Bridges</i>
<i>MVEU-732A-0</i>	<i>Alternate Supports for Conduits on Bridges</i>
<i>MVEU-732B-0</i>	<i>Alternate Supports for Conduits on Bridges</i>
<i>MVEU-733-0</i>	<i>Expansion Joint for Plastic Conduit</i>

CITY OF MORENO VALLEY APPROVALS				STAMP	ENGINEER'S APPROVAL	CITY OF MORENO VALLEY	ACCT No
LEANETTE SAO ELECTRIC UTILITY MANAGER DATE _____					SIGNATURE _____ ENGINEER # _____ EXP. _____	TYPE OF DESIGN TRACT OR PARCEL No CROSS STREETS	SHEET OF X CITY ID No XXXX
PUBLIC WORKS DIRECTOR/CITY ENGINEER RES. APPROV. DATE _____							
MARK	DATE	INITIAL	FOR	DESCRIPTION	REVISION		

1. ALL WORK SHALL BE DONE IN ACCORDANCE WITH THE CITY OF MORENO VALLEY STANDARD SPECIFICATIONS FOR PUBLIC WORKS.

**DISCLAIMER**  
 CALL FOR PERMITS  
 \*PERMITS OBTAIN FROM PVU.ORG

NOT TO SCALE

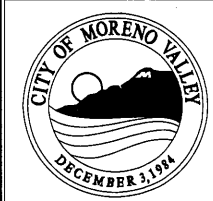

RECOMMENDED:  
  
 DIVISION MANAGER      DATE 12-27-16

APPROVED:  
  
 PUBLIC WORKS DIRECTOR / DATE 1/20/17  
 CITY ENGINEER

**CITY OF MORENO VALLEY**  
 PUBLIC WORKS DEPARTMENT - ELECTRIC UTILITY DIVISION

**TITLE SHEET BASE**  
**(FOR ELECTRIC UTILITY DIVISION)**

STANDARD PLAN  
**MVEU-700-0**

**CONDUIT & CABLE CALL-OUT DESIGNATION**

**PRIMARY CONDUIT SYSTEM**

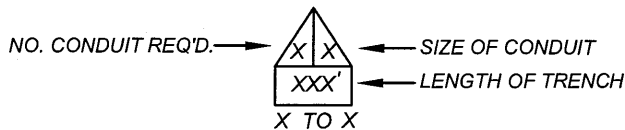

LENGTH OF CABLE - SIZE OF CABLE

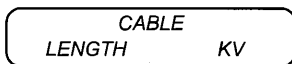

S-XXX TO S-XXX  
RUN  
EQ PULL= X,XXX

**SECONDARY CONDUIT SYSTEM**

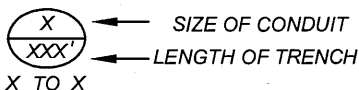

LENGTH OF CABLE - SIZE OF CABLE

**STREET LIGHT SYSTEM**

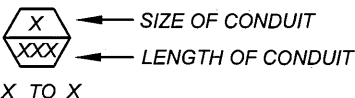

LENGTH OF CABLE - SIZE OF CABLE

SL NUMBERING = SL - YYY - # - MV  
 YYY = TRANSFORMER NUMBER  
 # = SL SEQUENCE NUMBER  
 MV = MORENO VALLEY DESIGNATOR

NOT TO SCALE

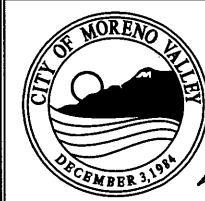

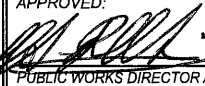









RECOMMENDED:  
 12-27-16  
 DIVISION MANAGER DATE  
 APPROVED:  
 1/20/17  
 PUBLIC WORKS DIRECTOR / DATE  
 CITY ENGINEER

**CITY OF MORENO VALLEY**  
 PUBLIC WORKS DEPARTMENT - ELECTRIC UTILITY DIVISION











**CONDUIT & CABLE CALL-OUTS**

STANDARD PLAN  
**MVEU-701-0**  
 SHEET 1 OF 1

LEGEND OF STRUCTURES



VAULT	
MANHOLE	
SOE	
PULL BOX	
STREET LIGHT	
HANDHOLE	
PAD	
PME/SUBSURFACE STRUCTURE	
PAD MOUNTED TRANSFORMER/SLAB BOX	
METER PEDESTAL	

LEGEND OF EQUIPMENT SYMBOLS

PM TRANSFORMER-1PH	
PM TRANSFORMER-3PH-RADIAL	
PM TRANSFORMER-3PH-LOOPING	
SWITCH-PME9	
SWITCH-PME10	
SWITCH-PME11	
LBFC (LOAD BREAK FUSE CABINET)	
CAPACITOR BANK	
SWITCH-GAS INSULATED	
INTERCONNECT PANEL	
METER PEDESTAL	

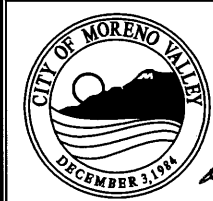
NOT TO SCALE



RECOMMENDED:  
 12.27.16  
 DIVISION MANAGER DATE  
 APPROVED:  
 1/20/17  
 PUBLIC WORKS DIRECTOR / DATE  
 CITY ENGINEER

**CITY OF MORENO VALLEY**  
 PUBLIC WORKS DEPARTMENT - ELECTRIC UTILITY DIVISION

**STRUCTURE & EQUIPMENT SYMBOLS**

STANDARD PLAN  
**MVEU-702-0**  
 SHEET 1 OF 1



## EQUIPMENT LEGEND AND NOTES

### FOR ELECTRICAL DRAWINGS

- SL \_\_\_ = STREET LIGHT
- T \_\_\_ = TRANSFORMER PAD  
& XFMR NUMBER
- X \_\_\_ = SPLICE BOX
- S \_\_\_ = PAD MOUNT SWITCH ENCLOSURE  
& SWITCH NUMBER
- C \_\_\_ = CAPACITOR
- H \_\_\_ = HANDHOLE
- LBFC \_\_\_ = LOAD BREAK FUSE CABINET
- M \_\_\_ = MANHOLE/SOE
- V \_\_\_ = VAULT

### RESIDENTIAL APPLICATIONS:

- TRANSFORMERS ARE 6.9 kV NF 120/240V 1ph, PAD MOUNTED WITH LOAD BREAK BUSHINGS.
- NON-FUSED HV CABLES IS 1/0 AWG AL 6.9kV JCN OR CIC.
- FUSED HV CABLE IS #2 AWG AL 6.9kV JCN OR CIC.
- SECONDARY CABLE IS 2-350 & 1-4/0 AL OR 2 4/0 & 1 1/0, 600V CLP UNLESS OTHERWISE SPECIFIED.
- SERVICE CABLE IS 2-1/0 & 1/#2 AL 600V CLP UNLESS OTHERWISE SPECIFIED.
- PRIMARY & SECONDARY CONDUITS ARE 3" UNLESS OTHERWISE SPECIFIED.
- SERVICE CONDUITS ARE 2 1/2" OR 3"
- BACKBONE SYSTEMS ARE AS DESIGNED PER NON-RESIDENTIAL CRITERIA.
- STREET LIGHTING SYSTEMS REQUIRE 2" CONDUIT BETWEEN SPLICE BOXES UNLESS OTHERWISE SPECIFIED.
- ALL 200A CABLE TERMINATIONS ARE LOAD BREAK ELBOWS.



### COMMERCIAL, INDUSTRIAL AND OTHER NON-RESIDENTIAL APPLICATIONS:

- TRANSFORMERS ARE NEW 12kV, FUSED SWITCHED 1ph OR 3ph (AS END USER REQUIREMENTS) PAD MOUNTED WITH LOAD BREAK ELBOWS.
- SWITCHES ARE 14.4kV NOMINAL PAD MOUNTED TYPE.
- CAPACITORS ARE 1200kVAR OR 1800kVAR, 12kV PAD MOUNTED, SWITCHED WITH FLOATING WYE CONNECTION WITH CONTROLLER.
- NON-FUSED HV CABLES ARE 1000 kcmil, 750 kcmil, 350 kcmil, 1/0 AWG AL 12kV JCN.
- FUSED HV CABLE IS #2 AWG AL 12kV JCN UNLESS OTHERWISE SPECIFIED.
- SECONDARY CABLE IS 3-350 & 1-4/0 AL 600V CLP UNLESS OTHERWISE SPECIFIED.
- SECONDARY & SERVICE CABLE IS 700kcmil, 350kcmil, 4/0kcmil, 1/0 AWG OR #2 AWG AL 600V CLP (AS PER END USER REQUIREMENTS).
- STRUCTURES ARE SUBSURFACE TYPE.
- PRIMARY CONDUITS ARE 5". UNLESS OTHERWISE SPECIFIED.
- SERVICE CONDUITS ARE 4" OR 5" AS SPECIFIED IN THE DISTRIBUTION DESIGN STANDARDS.
- COMMUNICATION CONDUITS ARE 2" AND INCLUDED WITH ALL BACKBONE (MAIN LINE) SYSTEMS.
- STREET LIGHTING SYSTEMS REQUIRE 2" CONDUIT BETWEEN SPLICE BOXES UNLESS SPECIFIED OTHERWISE.

### NOTE:

1. CONDUITS ARE DB-100 OR SCH 40-80 WHERE EXPOSED TO SUNLIGHT.
2. THE ABOVE CRITERIA DEFINE THE GENERAL REQUIREMENTS FOR THE DESIGN OF THE ELECTRICAL SYSTEMS. FOR SPECIFIC DESIGN APPLICATIONS REFER TO THE CITY OF MORENO VALLEY DISTRIBUTION DESIGN CRITERIA. IT CAN BE OBTAINED AT THE MORENO VALLEY UTILITY OFFICE.
3. ORANGE INSULATED COPPER CLAD STEEL TRACER WIRE PER KRISTECH SPECIFICATIONS SHEET, OR EQUAL. TRACER WIRE TO BE INSTALLED 2" ABOVE COMMUNICATION CONDUIT PER "THE COMPLETE UTILITY LOCATING SYSTEM SPECIFICATIONS FOR TELECOMMUNICATIONS" BY COPPERHEAD INDUSTRIES, OR EQUIVALENT.

NOT TO SCALE

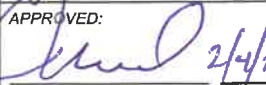
	RECOMMENDED:  1-20-22 DIVISION MANAGER      DATE	<h2 style="margin: 0;">CITY OF MORENO VALLEY</h2> <p style="margin: 0;">FINANCIAL &amp; MANAGEMENT SERVICES DEPARTMENT - ELECTRIC UTILITY DIVISION</p>	STANDARD PLAN
	APPROVED:  2/4/22 PUBLIC WORKS DIRECTOR / DATE CITY ENGINEER	<h3 style="margin: 0;">EQUIPMENT LEGENDS</h3>	<h3 style="margin: 0;">MVEU-703-1</h3>

**EXAMPLE-VICINITY MAP**

NO SCALE RIV CO. 807 H2 (THOMAS GUIDE REFERENCE)

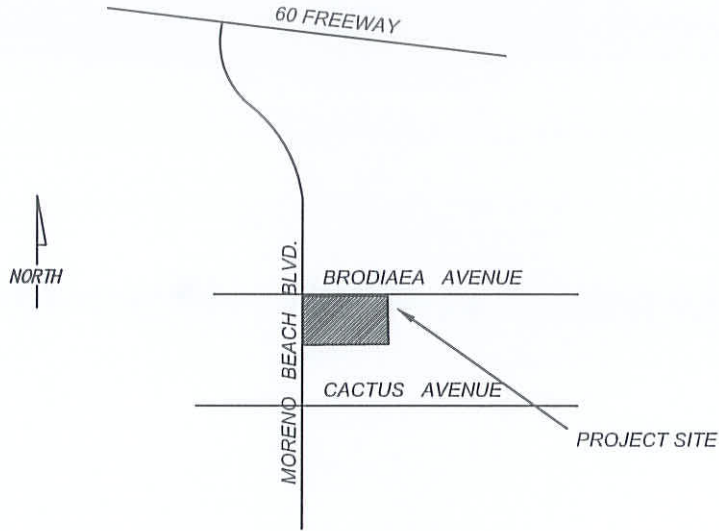

**EXAMPLE-PROJECT MAP**

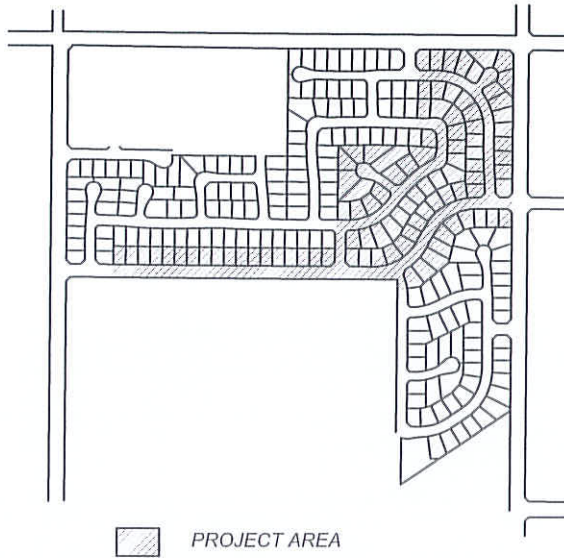

NOT TO SCALE

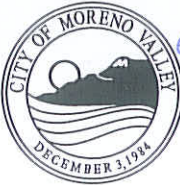
	RECOMMENDED: <i>[Signature]</i> 1-15-14 DIVISION MANAGER DATE	<b>CITY OF MORENO VALLEY</b> PUBLIC WORKS DEPARTMENT - ELECTRIC UTILITY DIVISION	STANDARD PLAN
	APPROVED: <i>[Signature]</i> 1/29/14 PUBLIC WORKS DIRECTOR / DATE CITY ENGINEER		<b>VICINITY &amp; PROJECT MAP</b>
			SHEET 1 OF 1

*PLANS ARE  
APPROVED FOR CONSTRUCTION  
WHEN SIGNED BY  
THE PUBLIC WORKS DIRECTOR/CITY ENGINEER*

NOT TO SCALE

	RECOMMENDED: <i>[Signature]</i> <u>1-15-14</u> DIVISION MANAGER      DATE	<b>CITY OF MORENO VALLEY</b> PUBLIC WORKS DEPARTMENT - ELECTRIC UTILITY DIVISION	STANDARD PLAN
	APPROVED: <i>[Signature]</i> <u>1/29/14</u> PUBLIC WORKS DIRECTOR / DATE CITY ENGINEER		<b>APPROVED STATUS STAMP</b>
			SHEET 1 OF 1

**DECLARATION OF DESIGN**

THE DESIGN OF THE ELECTRICAL POWER SYSTEM AS SHOWN ON THESE PLANS COMPLIES WITH PROFESSIONAL ENGINEERING STANDARDS AND PRACTICES INCLUDING OBSERVANCE OF MINIMUM VERTICAL AND HORIZONTAL DISTANCES, IN ACCORDANCE WITH APPLICABLE REGULATIONS, FROM EXISTING FACILITIES INCLUDING BUT NOT LIMITED TO WATER AND SEWER LINES, STORM DRAINS, TELECOMMUNICATIONS AND CABLE TELEVISION SYSTEMS. THE DESIGN INCORPORATES PROPER SEPARATION FROM SUCH FACILITIES TO BE INSTALLED AS PART OF THE DEVELOPMENT.

NAME \_\_\_\_\_ DATE \_\_\_\_\_  
ADDRESS \_\_\_\_\_ PHONE \_\_\_\_\_

NOT TO SCALE

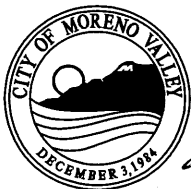

RECOMMENDED:  
*gdo* 12-27-16  
DIVISION MANAGER DATE

APPROVED:  
*[Signature]* 1/20/17  
PUBLIC WORKS DIRECTOR / DATE  
CITY ENGINEER

**CITY OF MORENO VALLEY**

PUBLIC WORKS DEPARTMENT - ELECTRIC UTILITY DIVISION

**DESIGNER DECLARATION**

STANDARD PLAN

**MVEU-706A-0**

SHEET 1 OF 2



**ENGINEER'S NOTICE TO CONTRACTORS**

THE EXISTENCE AND LOCATION OF ANY UNDERGROUND UTILITY PIPES OF STRUCTURES SHOWN ON THESE PLANS WERE OBTAINED BY A SEARCH OF AVAILABLE RECORDS. THESE LOCATIONS ARE APPROXIMATE AND SHALL BE CONFIRMED IN FIELD BY THE CONTRACTOR, SO THAT ANY NECESSARY ADJUSTMENT CAN BE MADE IN ALIGNMENT AND/OR GRADE OF THE PROPOSED IMPROVEMENT. THE CONTRACTOR IS REQUIRED TO TAKE DUE PRECAUTIONARY MEASURE TO PROTECT ANY UTILITY LINES SHOWN AND ANY OTHER LINES NOT OF RECORD OR NOT SHOWN ON THESE PLANS.

NOT TO SCALE

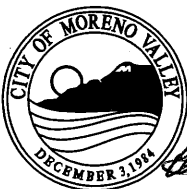

RECOMMENDED:

*go* 12-27-16  
DIVISION MANAGER DATE

APPROVED:

*[Signature]* 1/20/17  
PUBLIC WORKS DIRECTOR / DATE  
CITY ENGINEER

**CITY OF MORENO VALLEY**

PUBLIC WORKS DEPARTMENT - ELECTRIC UTILITY DIVISION

**ENGINEER'S NOTICE  
TO CONTRACTORS**

STANDARD PLAN

**MVEU-706B-0**

SHEET 2 OF 2

*Statement of Plan Review*

*Electrical Distribution Plan Check.*

*ENCO Utility Services, an agent for the City of Moreno Valley, has reviewed the electrical distribution plans on Tract # \_\_\_\_\_ for conformance to City Standards and general electrical design. ENCO recommends these plans for City approval.*

*Name: \_\_\_\_\_  
ENCO Utility Services*

*Signed \_\_\_\_\_ Date \_\_\_\_\_*

NOT TO SCALE

	RECOMMENDED: <i>[Signature]</i> <i>1-15-14</i> DIVISION MANAGER / DATE	<b>CITY OF MORENO VALLEY</b> PUBLIC WORKS DEPARTMENT - ELECTRIC UTILITY DIVISION	STANDARD PLAN
	APPROVED: <i>[Signature]</i> <i>1/29/14</i> PUBLIC WORKS DIRECTOR / DATE CITY ENGINEER		<b>STATEMENT OF PLAN REVIEW</b> <b>MVEU-707A-0</b> SHEET 1 OF 2

*Statement of Plan Review*

*Electrical Distribution Plan Check.*

*Moreno Valley Electric Utility (MVU) has reviewed the electrical distribution plans on Tract # \_\_\_\_\_ for conformance to City Standards and general electrical design. MVU recommends these plans for approval.*

Name: \_\_\_\_\_

*MVU Electric Engineering*

\_\_\_\_\_  
Signed Date

NOT TO SCALE

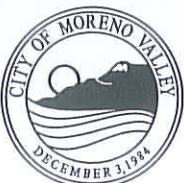

RECOMMENDED:  
*[Signature]* 1-15-14  
DIVISION MANAGER DATE  
APPROVED:  
*[Signature]* 1/29/14  
PUBLIC WORKS DIRECTOR / DATE  
CITY ENGINEER

**CITY OF MORENO VALLEY**  
PUBLIC WORKS DEPARTMENT - ELECTRIC UTILITY DIVISION

**STATEMENT OF PLAN REVIEW**

STANDARD PLAN  
**MVEU-707B-0**

SHEET 2 OF 2

**LOAD INFORMATION**

AVG. HOME SIZE                    SQ FEET  
AVG. A/C                            TON(s)  
LARGEST A/C UNIT                TON(s)  
PANEL SIZE                        AMPS  
DESIGN KW/UNIT                 KW  
NUMBER OF UNITS                \_\_\_\_\_  
NO. OF STREET LIGHTS         \_\_\_\_\_

**XFMR DESIGN PARAMETERS**

CUST/50 KVA XFMR               MAX. UNITS  
CUST/75 KVA XFMR               MAX. UNITS  
CUST/100 KVA XFMR\*           MAX. UNITS  
\* MULTI-FAMILY ONLY.

NOT TO SCALE

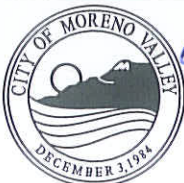

RECOMMENDED:  
*[Signature]* 1-15-14  
DIVISION MANAGER                DATE

APPROVED:  
*[Signature]* 1/29/14  
PUBLIC WORKS DIRECTOR/        DATE  
CITY ENGINEER

**CITY OF MORENO VALLEY**  
PUBLIC WORKS DEPARTMENT - ELECTRIC UTILITY DIVISION

**DESIGN INFORMATION**

STANDARD PLAN  
**MVEU-708-0**

SHEET 1 OF 1



**MORENO VALLEY STANDARD NO. MVEU-709-1**

3,800 LUMENS, LED, 120v, FLAT CUT-OFF  
WITH MARBELITE POLES  
SEE STD PLAN MVL-400A

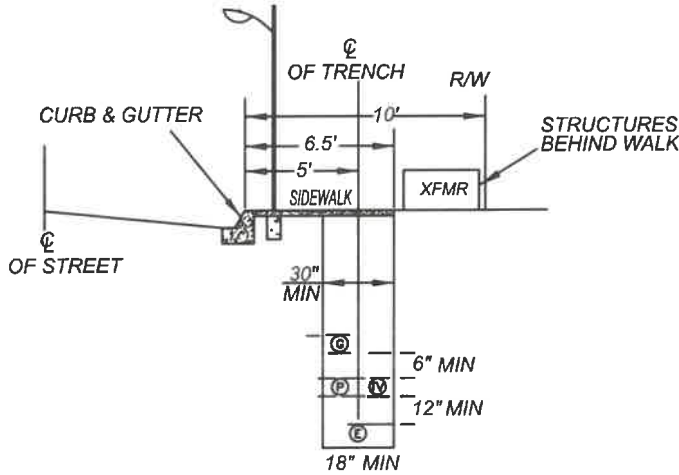

NOTE:  
XFMR - TRANSFORMER  
PMH - PAD MOUNT ENCLOSE

**TRENCH DETAIL  
RESIDENTIAL & COLLECTOR STREETS**

11,500 LUMENS, LED, 120v FLAT CUT-OFF  
WITH MARBELITE POLES  
SEE STD PLAN MVL-400B AND/OR MVL-400C

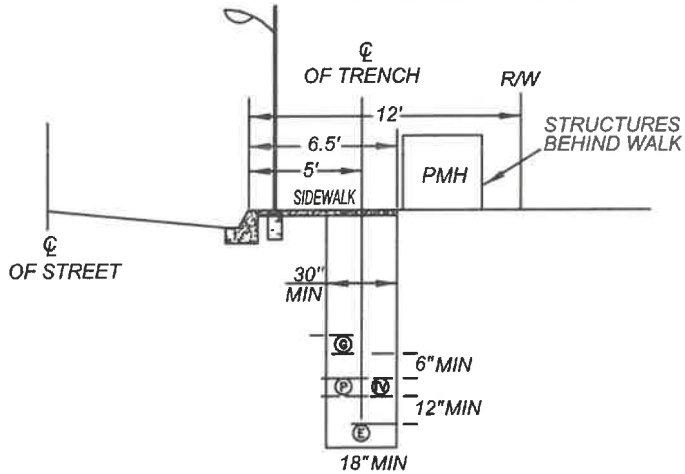

**TRENCH DETAIL  
ARTERIAL STREET**

**NOTE:**

1. ORANGE INSULATED COPPER GLAD STEEL TRACER WIRE PER KRISTECH SPECIFICATIONS SHEET, OR EQUAL. TRACER WIRE TO BE INSTALLED 2" ABOVE COMMUNICATION CONDUIT PER "THE COMPLETE UTILITY LOCATING SYSTEM SPECIFICATIONS FOR TELECOMMUNICATIONS" BY COPPERHEAD INDUSTRIES, OR EQUIVALENT.

NOT TO SCALE



RECOMMENDED:  
*[Signature]* 12-21-2021  
DIVISION MANAGER DATE  
APPROVED:  
*[Signature]* 2/4/22  
PUBLIC WORKS DIRECTOR / DATE  
CITY ENGINEER

**CITY OF MORENO VALLEY**  
FINANCIAL & MANAGEMENT SERVICES DEPARTMENT - ELECTRIC UTILITY DIVISION

**DRY UTILITIES TRENCH  
SECTION**

STANDARD PLAN  
**MVEU-709-1**

SHEET 1 OF 1

MORENO VALLEY STANDARD NO. MVEU-710A-0

RESIDENTIAL SINGLELINE

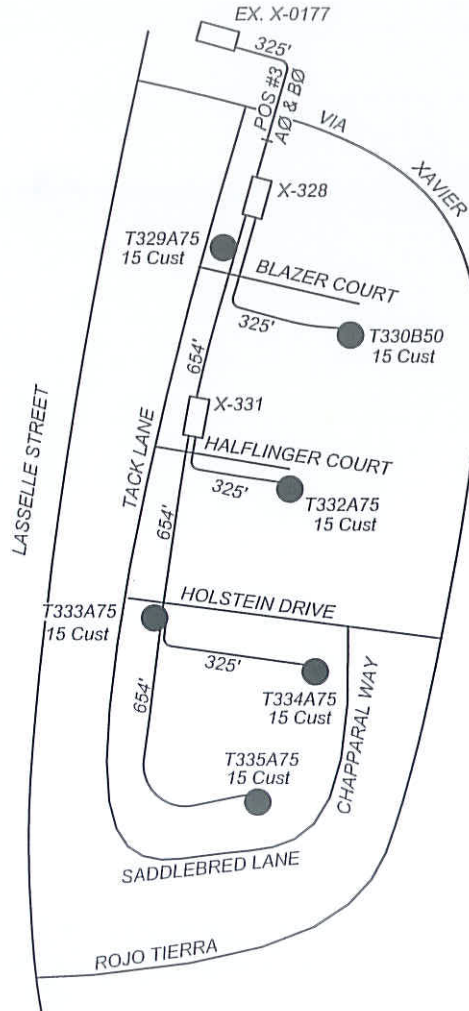

NOTES:

1. SEE STD MVUE-702-0

NOT TO SCALE

	RECOMMENDED: <i>[Signature]</i> 1/5/14 DIVISION MANAGER DATE	<b>CITY OF MORENO VALLEY</b> PUBLIC WORKS DEPARTMENT - ELECTRIC UTILITY DIVISION	
	APPROVED: <i>[Signature]</i> 1/29/14 PUBLIC WORKS DIRECTOR / DATE CITY ENGINEER	<b>ELECTRIC SINGLELINE DIAGRAM</b> <b>RESIDENTIAL</b>	

MORENO VALLEY STANDARD NO. MVEU-710B-0

**BACKBONE RESIDENTIAL SINGLELINE**

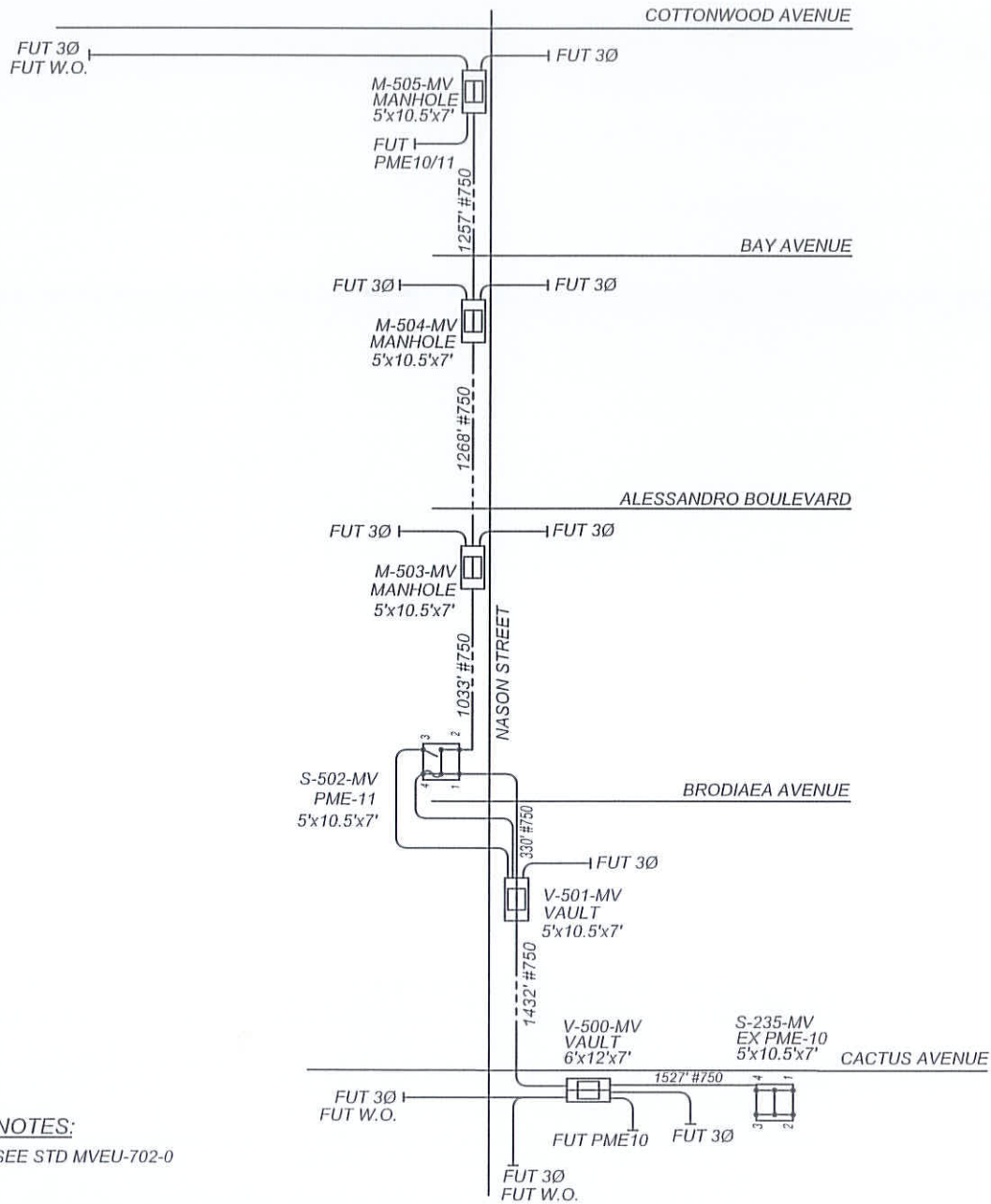

**NOTES:**

1. SEE STD MVEU-702-0

NOT TO SCALE

	RECOMMENDED: <i>[Signature]</i> 1/15/14 DIVISION MANAGER DATE	<b>CITY OF MORENO VALLEY</b> PUBLIC WORKS DEPARTMENT - ELECTRIC UTILITY DIVISION	
	APPROVED: <i>[Signature]</i> 1/29/14 PUBLIC WORKS DIRECTOR / DATE CITY ENGINEER	<b>ELECTRICAL SINGLELINE                  DIAGRAM BACKBONE</b>	

MORENO VALLEY STANDARD No MVEU-711A-0

**48" x 54" PAD FOR  
PAD MOUNTED &  
MINI PAD MOUNTED TRANSFORMER**

PAD MOUNTED & MINI PAD  
MOUNTED TRANSFORMERS  
SECONDARY AREA  
SECONDARY AND SERVICE  
CABLES MUST BE INSTALLED  
IN UNSHADED AREA

PAD MOUNTED & MINI PAD  
MOUNTED TRANSFORMERS  
PRIMARY AREA  
PRIMARY CABLES MUST  
BE INSTALLED IN SHADED  
AREA

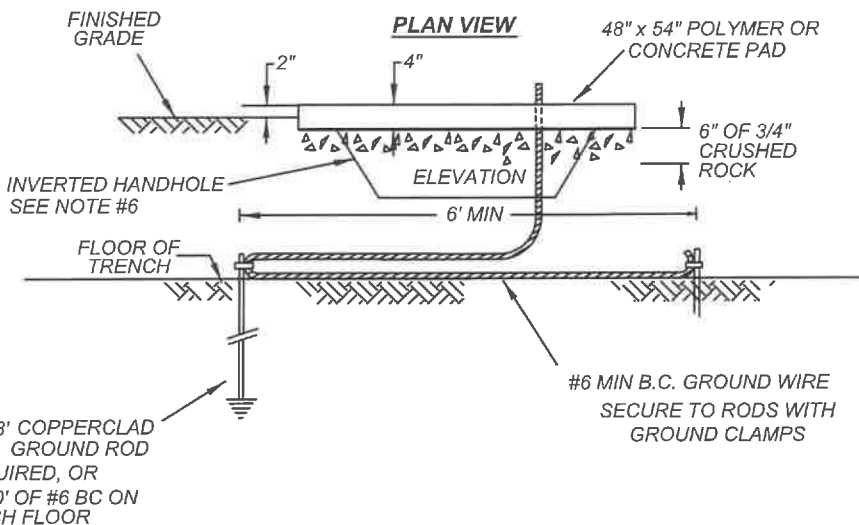
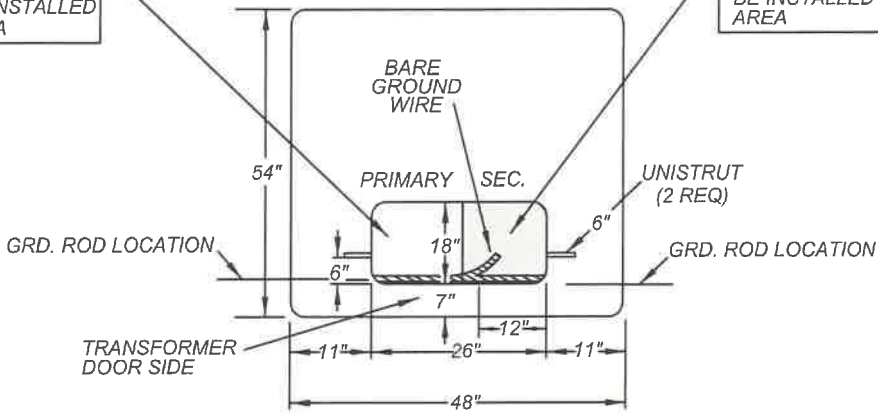

\*GROUNDING MATERIALS FURNISHED  
AND INSTALLED BY CONTRACTOR.

**NOTES:**

1. 8' UNOBSTRUCTED FLAT WORKING CLEARANCE IS REQUIRED AT FRONT OF PAD. (MEASURED FROM EDGE OF PAD)
2. 3' UNOBSTRUCTED CLEARANCE IS REQUIRED AT BACK OF PAD. (MEASURED FROM EDGE OF PAD)
3. 3' CLEARANCE IS REQUIRED ON BOTH SIDES OF PAD. (MEASURED FROM EDGE OF PAD)
4. MASTIC SEALANT REQUIRED AT JOINTS AND GAPS AROUND TRANSFORMER ENCLOSURE.
5. SEE STDS MVEU-711B-0, MVEU-722-0, & MVEU-723-0 FOR ADDITIONAL DETAILS.
6. INVERTED HH 13"x24"x15" REQUIRED FOR ALL MINI PAD MOUNTED TRANSFORMERS AND ALL DUCT INSTALLATIONS

NOT TO SCALE

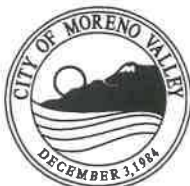

RECOMMENDED:  
*[Signature]* 6-20-19  
DIVISION MANAGER DATE  
APPROVED:  
*[Signature]* 7/30/19  
PUBLIC WORKS DIRECTOR / DATE  
CITY ENGINEER

**CITY OF MORENO VALLEY**  
FINANCIAL & MANAGEMENT SERVICES DEPARTMENT - ELECTRIC UTILITY DIVISION

**48" x 54" PAD FOR PAD  
MOUNTED & MINI PAD  
MOUNTED TRANSFORMER**

STANDARD PLAN  
**MVEU-711A-0**

SHEET 1 OF 1



MORENO VALLEY STANDARD NO. MVEU-711B-0

**TYPICAL REQUIREMENTS FOR 6.9 KV  
SINGLE-PHASE MINI-PAD MOUNTED TRANSFORMER**

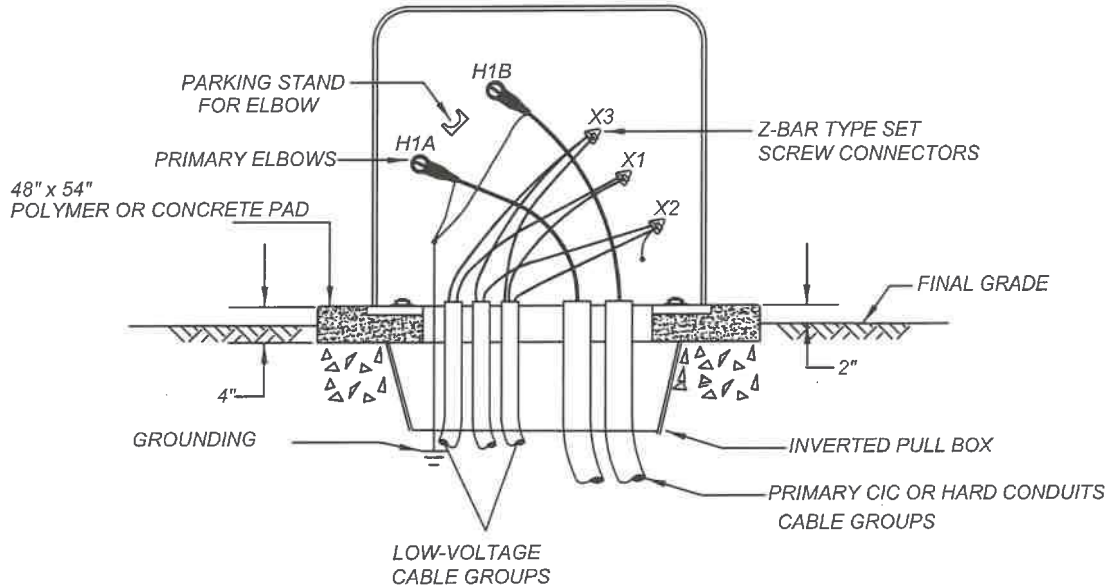

**NOTES:**

1. A MAXIMUM OF 6 LOW-VOLTAGE CABLES CAN BE PLACED INTO A MINI-PAD MOUNT TRANSFORMER. ONE CABLE RUN IS EITHER ONE SECONDARY OR ONE SERVICE RUN (MAXIMUM 350 KCMIL), UP TO TWO ADDITIONAL #8 STREET LIGHT RUNS MAY BE ADDED.
2. USE ALUMINUM BAR-TYPE SET-SCREW CONNECTORS.
3. USE OF MINI-PAD MOUNT TRANSFORMER REQUIRES A 13"x24"x 15" INVERTED PLASTIC PULL BOX UNDER THE CABLE OPENING IN THE PAD. THIS IS NECESSARY TO PROVIDE ADEQUATE CABLE SLACK FOR OPERATION OF THE LOADBREAK/DEADBREAK ELBOWS. SEAL THE BOTTOM OF THE HANDHOLE OPENING AROUND THE CIC OR CONDUITS WITH A THIN LAYER OF REDI-CRETE (OR EQUIVALENT) FOR RODENT OR WEED CONTROL.
4. GAPS BETWEEN CONCRETE OR POLYMER PADS AND PAD-MOUNTED EQUIPMENT SHALL BE SEALED TO PREVENT A PERSON FROM PASSING A WIRE OR OTHER CONDUCTING MATERIAL INTO THE COMPARTMENT WITH EXPOSED LIVE PARTS. (G.O. 128, 34.3). THIS WILL ALSO PREVENT TAMPERING, REDUCE MOISTURE ENTRY, AND DETER RODENT/VERMINE NESTING INSIDE THE EQUIPMENT.

NOT TO SCALE

	RECOMMENDED:  <span style="float: right;">6/20/19</span> DIVISION MANAGER / DATE	<h2 style="margin: 0;">CITY OF MORENO VALLEY</h2> <p style="margin: 0;">FINANCIAL &amp; MANAGEMENT SERVICES DEPARTMENT - ELECTRIC UTILITY DIVISION</p>	
	APPROVED:  <span style="float: right;">7/30/19</span> PUBLIC WORKS DIRECTOR / DATE CITY ENGINEER	<h3 style="margin: 0;">MINI PAD MOUNTED TRANSFORMER CABLE CONNECTIONS</h3>	
			SHEET 1 OF 1

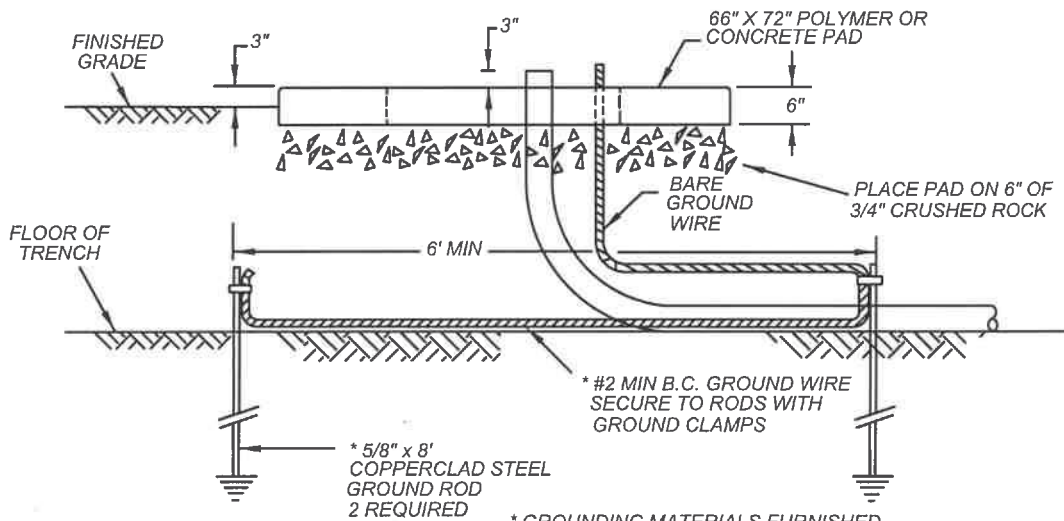
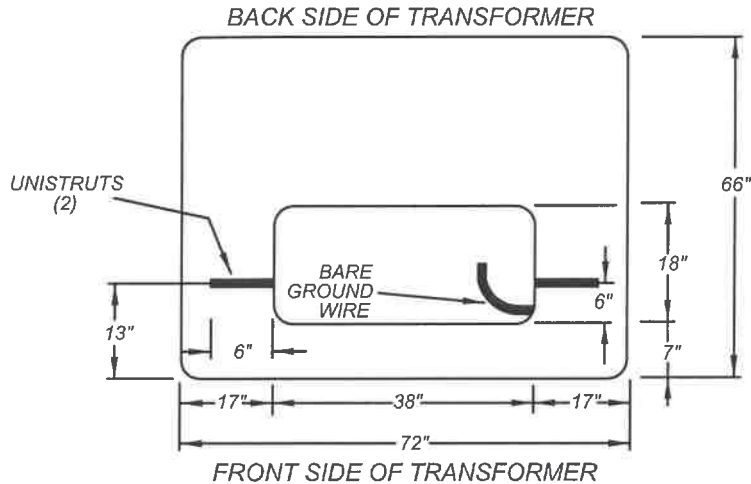

**MORENO VALLEY STANDARD No MVEU-712-1**  
**66" x 72" PAD FOR 75kVA-300kVA**  
**PAD MOUNTED TRANSFORMERS**



**NOTES:**

1. 8' UNOBSTRUCTED FLAT WORKING CLEARANCE IS REQUIRED AT FRONT OF PAD. (MEASURED FROM EDGE OF PAD)
2. 3' UNOBSTRUCTED CLEARANCE IS REQUIRED AT BACK OF PAD. (MEASURED FORM EDGE OF PAD)
3. 3' CLEARANCE IS REQUIRED ON BOTH SIDES OF PAD. (MEASURED FROM EDGE OF PAD)
4. MASTIC SEALANT REQUIRED AT JOINTS AND GAPS AROUND TRANSFORMER ENCLOSURE.
5. REFER TO STDS MVEU-722-0 & MVEU-723-0 FOR ADDITIONAL DETAILS.
6. THE THREE-PHASE TRANSFORMER SHOULD ONLY BE USED ON A PAD WHEN FOUR OR FEWER SERVICES ARE TO BE INSTALLED. A SLAB BOX SHOULD BE USED WHEN MORE THAN FOUR SERVICES WILL BE INSTALLED.

NOT TO SCALE

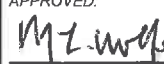
	RECOMMENDED:  DIVISION MANAGER	8-1-19 DATE	<h2 style="margin: 0;">CITY OF MORENO VALLEY</h2> <p style="margin: 0;">FINANCIAL &amp; MANAGEMENT SERVICES DEPARTMENT - ELECTRIC UTILITY DIVISION</p>	STANDARD PLAN <b>MVEU-712-1</b>
	APPROVED:  PUBLIC WORKS DIRECTOR / CITY ENGINEER	8/1/19 DATE	<h3 style="margin: 0;">66" x 72" PAD</h3> <h3 style="margin: 0;">FOR 75kVA - 300kVA</h3> <h3 style="margin: 0;">PAD MOUNTED TRANSFORMERS</h3>	SHEET 1 OF 1







MORENO VALLEY STANDARD NO. MVEU-715-0

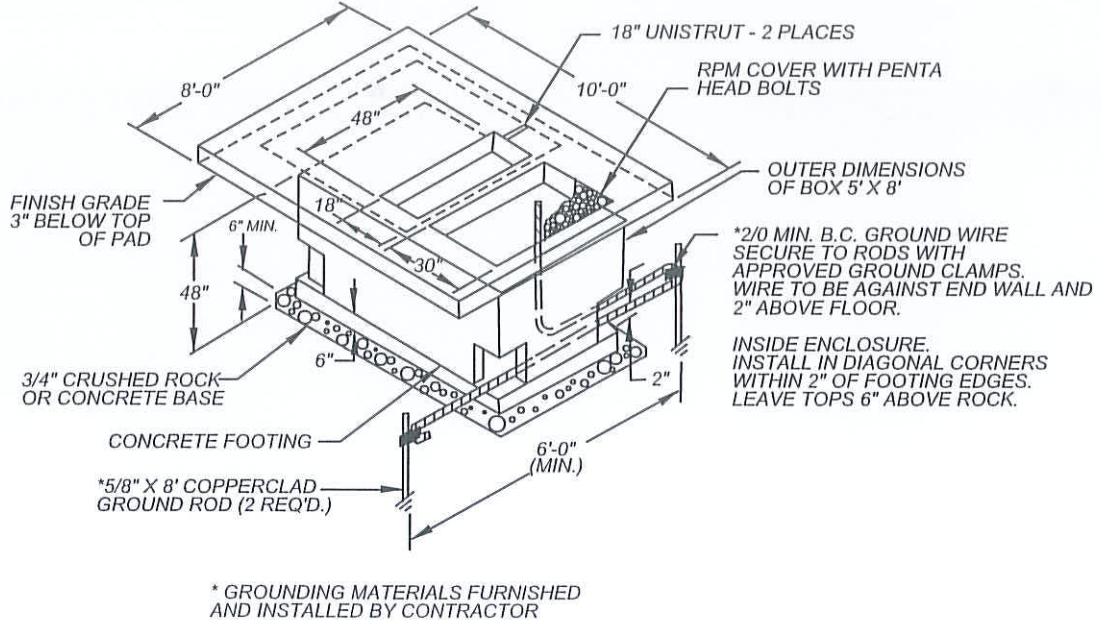

**8' x 10' PAD WITH  
4'-10" x 7'-10" x 4' BOX FOR  
750kVA - 1000kVA PAD MOUNTED TRANSFORMERS**



**NOTES:**

1. 8' UNOBSTRUCTED FLAT WORKING CLEARANCE IS REQUIRED AT FRONT OF PAD. (MEASURED FROM EDGE OF PAD)
2. 3' UNOBSTRUCTED CLEARANCE IS REQUIRED AT BACK OF PAD. (MEASURED FORM EDGE OF PAD)
3. 3' CLEARANCE IS REQUIRED ON BOTH SIDES OF PAD. (MEASURED FROM EDGE OF PAD)
4. MASTIC SEALANT REQUIRED AT JOINTS AND GAPS AROUND TRANSFORMER ENCLOSURE.
5. REFER TO STDS MVEU-722-0 & MVEU-723-0 FOR ADDITIONAL DETAILS.

NOT TO SCALE

	RECOMMENDED:  1-15-14 DIVISION MANAGER DATE	<b>CITY OF MORENO VALLEY</b> PUBLIC WORKS DEPARTMENT - ELECTRIC UTILITY DIVISION	
	APPROVED:  1/29/14 PUBLIC WORKS DIRECTOR / DATE CITY ENGINEER	<b>8' x 10' PAD WITH BOX FOR 750kVA - 1000kVA PAD MOUNTED TRANSFORMERS</b>	

MORENO VALLEY STANDARD NO. MVEU-716-0

**10' x 12' PAD WITH  
5'-10" x 9'-4" x 5'-7" BOX FOR  
1500kVA - 2500 kVA PAD MOUNTED TRANSFORMERS**

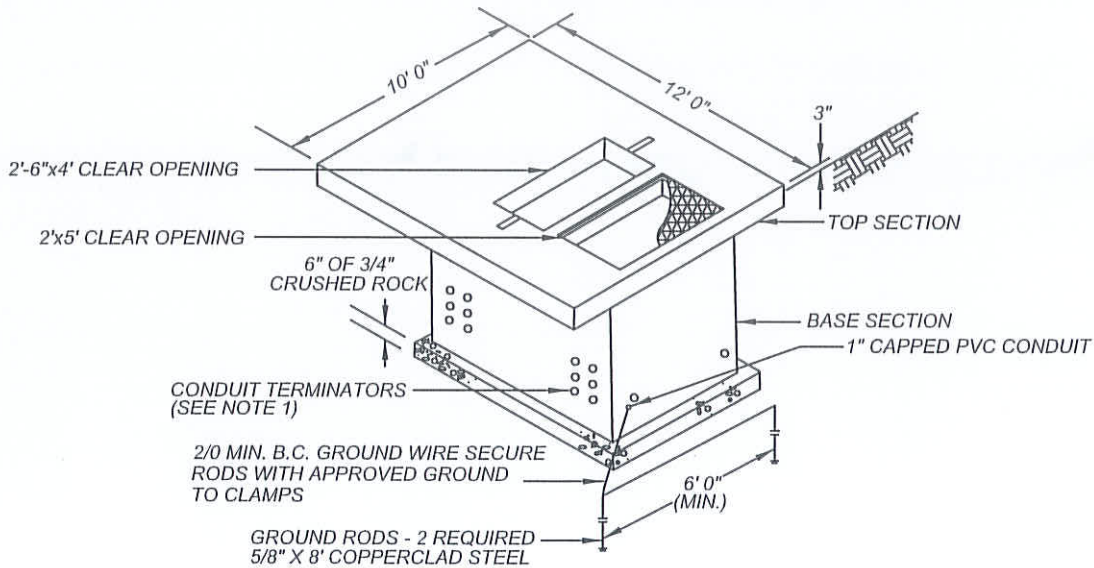

**NOTES:**

1. CONDUIT TERMINATORS TO BE LOCATED AS SHOWN. STANDARD CONDUIT ENTRANCE SHALL BE A FLATWALL DESIGN. SLIGHT VARIATIONS BY MANUFACTURERS MAY BE ALLOWED WITH CITY APPROVAL.
2. WHEN CABLE TRENCH OPENINGS ARE REQUIRED IN A SLAB BOX, THEY CAN BE SPECIAL ORDERED FROM THE CONCRETE PRECASTER.
3. CONSULT MANUFACTURER'S INSTALLATION GUIDES FOR EXCAVATION DIMENSIONS.
4. AN EIGHT FOOT MINIMUM CLEARANCE IS REQUIRED DIRECTLY IN FRONT OF TRANSFORMER FOR OPERATION.
5. GROUND RODS, CLAMPS, AND WIRE WILL BE FURNISHED BY CONTRACTOR. GROUND WIRE TO BE A MINIMUM OF 2/0 BARE COPPER. GROUND WIRE TO BE PLACED THROUGH ONE-INCH PVC CONDUIT AT EITHER END OF SLAB BOX. A MINIMUM THREE-FOOT LENGTH OF GROUND WIRE SHALL BE PLACED IN SLAB BOX.
6. MASTIC SEALANT REQUIRED AT JOINTS AND GAPS AROUND TRANSFORMER ENCLOSURE.
7. TOP SURFACE OF SLAB BOX SHALL BE SET THREE INCHES ABOVE FINISHED GRADE.
8. 8' UNOBSTRUCTED FLAT WORKING CLEARANCE IS REQUIRED AT FRONT OF PAD. (MEASURED FROM EDGE OF PAD)
9. 3' UNOBSTRUCTED CLEARANCE IS REQUIRED AT BACK OF PAD. (MEASURED FORM EDGE OF PAD)
10. 3' CLEARANCE IS REQUIRED ON BOTH SIDES OF PAD. (MEASURED FROM EDGE OF PAD)
11. REFER TO STDS MVEU-722-0 & MVEU-723-0 FOR ADDITIONAL DETAILS.

NOT TO SCALE

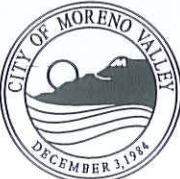
	RECOMMENDED: <i>[Signature]</i> 1-15-14 DIVISION MANAGER      DATE	<b>CITY OF MORENO VALLEY</b> PUBLIC WORKS DEPARTMENT - ELECTRIC UTILITY DIVISION	
	APPROVED: <i>[Signature]</i> 1/29/14 PUBLIC WORKS DIRECTOR / DATE CITY ENGINEER	<b>10' x 12' PAD WITH BOX FOR 1500kVA - 2500kVA PAD MOUNTED TRANSFORMERS</b>	



MORENO VALLEY STANDARD NO. MVEU-717-0

72" X 94" PAD FOR PAD MOUNTED CAPACITORS

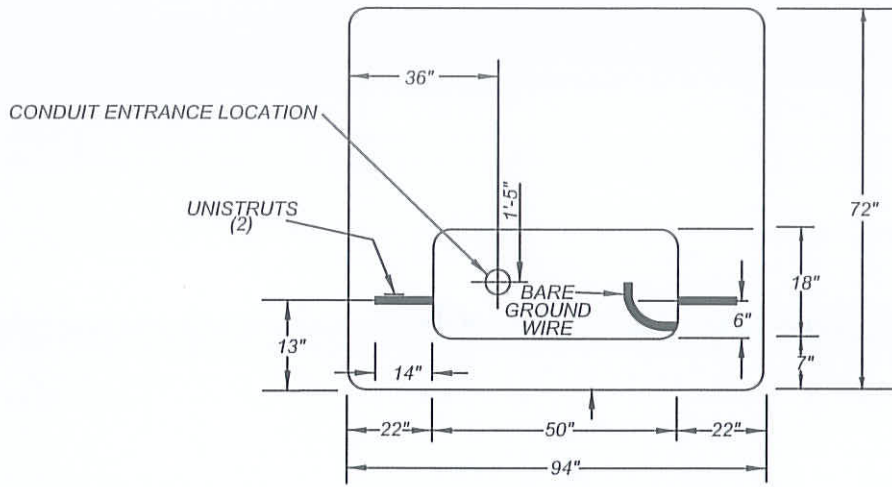

**BACK SIDE OF CAPACITOR**

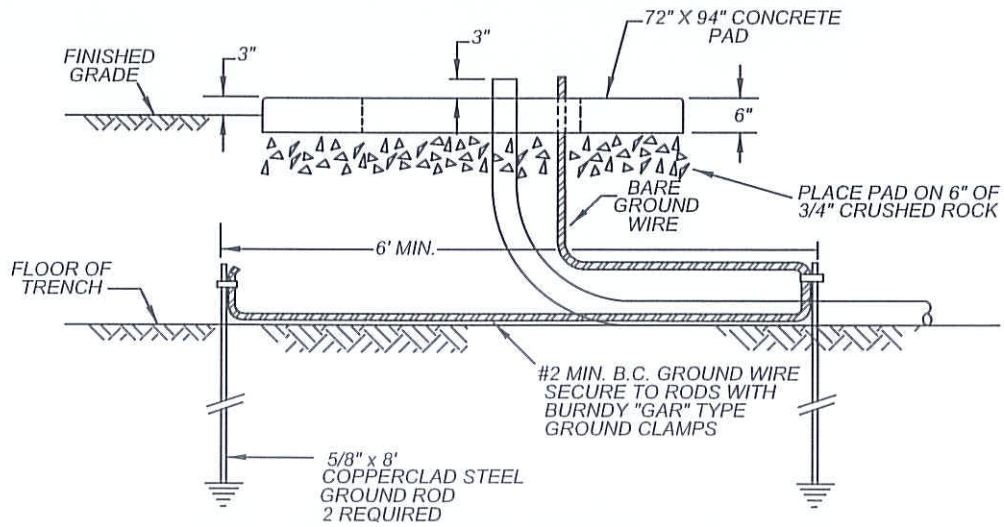

**FRONT SIDE OF CAPACITOR**

(\*) - AS MEASURED FROM EDGE OF PAD

**NOTES:**

1. 8' UNOBSTRUCTED FLAT WORKING CLEARANCE (\*) IS REQUIRED AT FRONT OF PAD.
2. 8' UNOBSTRUCTED FLAT WORKING CLEARANCE (\*) IS REQUIRED AT BACK OF PAD.
3. 3' CLEARANCE (\*) IS REQUIRED ON BOTH SIDES OF PAD.
4. REFER TO STDS MVEU-722-0 & MVEU-723-0 FOR ADDITIONAL DETAILS.

NOT TO SCALE

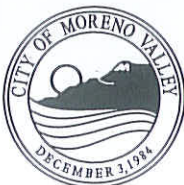

RECOMMENDED:  
*[Signature]* 1-15-14  
 DIVISION MANAGER DATE

APPROVED:  
*[Signature]* 1/29/14  
 PUBLIC WORKS DIRECTOR / DATE  
 CITY ENGINEER

**CITY OF MORENO VALLEY**  
 PUBLIC WORKS DEPARTMENT - ELECTRIC UTILITY DIVISION

**72" X 94" PAD  
 FOR PAD-MOUNTED  
 CAPACITORS**

STANDARD PLAN  
**MVEU-717-0**

SHEET 1 OF 1

MORENO VALLEY STANDARD NO. MVEU-718-0  
**PMH TUB-STYLE CONCRETE ENCLOSURE**  
**5' x 10'-6" x 7'**  
**(PMH-6 THRU PMH-14)**

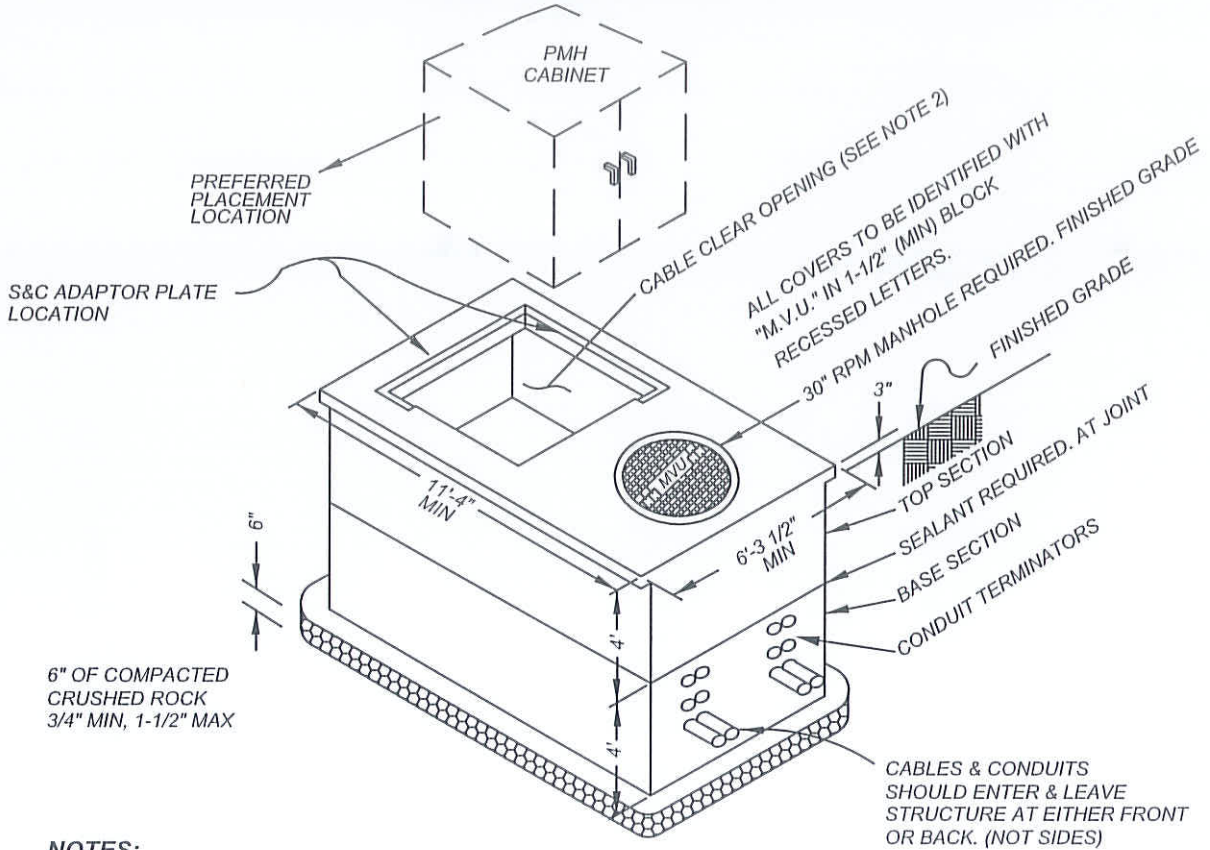

**NOTES:**

1. TOP & BOTTOM SECTIONS PROVIDED WITH GROUNDING INSERTS.
2. CABLE CLEAR OPENING SHALL BE COVERED WITH AN ELECTRICAL-APPROVED COVER AT THE TIME OF STRUCTURE PLACEMENT.
3. KEEP BARRIER PLATES BANDED AND PLACE IN BOTTOM OF BASE SECTION.
4. BACKFILL AROUND THE STRUCTURE SHALL BE WITH A MINIMUM OF ONE SACK PER YARD SAND CEMENT SLURRY TO WITHIN ONE FOOT OF FINISHED GRADE. THE SURFACE ELEVATION OF THE SLURRY SHALL NOT VARY MORE THAN 1'-0" AROUND THE PERIMETER OF THE STRUCTURE AS IT IS BEING PLACED.
5. 8' UNOBSTRUCTED FLAT WORKING CLEARANCE IS REQUIRED AT DOOR SIDES OF CABINET. (MEASURED FROM EDGE OF PAD)
6. 3' UNOBSTRUCTED CLEARANCE IS REQUIRED AT NON-DOOR SIDES OF CABINET. (MEASURED FROM EDGE OF PAD)
7. MINIMUM EXCAVATION PER MANUFACTURER'S RECOMMENDATIONS.
8. REFER TO STDS MVEU-722-0 & MVEU-723-0 FOR ADDITIONAL DETAILS.
9. ENCLOSURE TO BE INSTALLED WITH PRIMARY GROUND ASSEMBLY.
10. ENCLOSURE TO BE INSTALLED WITH CABLE RACK ASSEMBLY.
11. PRIMARY GROUND HALO TO BE #4 /O BC AND ATTACHED TO ALL GROUND INSERTS.

NOT TO SCALE

	RECOMMENDED: <i>[Signature]</i> 1-15-14 DIVISION MANAGER DATE	<b>CITY OF MORENO VALLEY</b> PUBLIC WORKS DEPARTMENT - ELECTRIC UTILITY DIVISION	STANDARD PLAN
	APPROVED: <i>[Signature]</i> 1/29/14 PUBLIC WORKS DIRECTOR / DATE CITY ENGINEER		<b>PAD MOUNTED SWITCH ENCLOSURE DETAIL</b> <b>5' x 10'-6" x 7'</b>
			SHEET 1 OF 1



MORENO VALLEY STANDARD NO. MVEU-719-0

17" x 30" x 24"

**SERVICE CONNECTION PULL BOX**

(FOR RESIDENTIAL ELECTRICAL SYSTEMS)

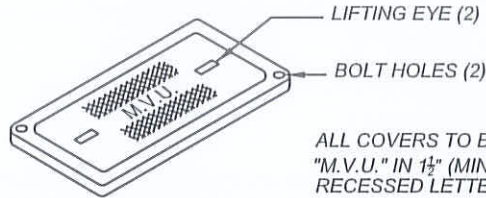

ALL COVERS TO BE IDENTIFIED WITH "M.V.U." IN 1½" (MIN) BLOCK RECESSED LETTERS.

**TYPICAL COVER**  
(CONCRETE OR PLASTIC)

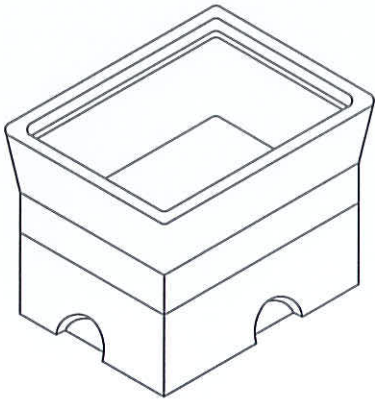

**TYPICAL ASSEMBLY WITHOUT COVER**  
(CONCRETE OR PLASTIC)

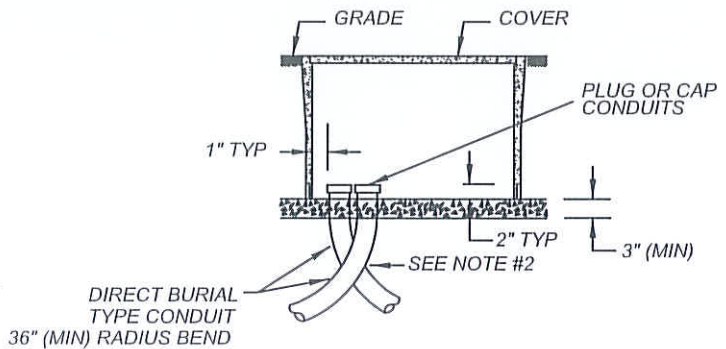

**SECTION A-A**

**ALL CONDUITS**



CONDUIT LOCATIONS

**NOTES:**

1. RADIUS ANGLE MAY BE REDUCED TO LESS THAN 90° PROVIDING THE PROJECTED CENTER LINE OF THE CONDUIT CLEARS HANDHOLE OPENING.
2. TWO HOLD DOWN DEVICES TO BE SUPPLIED WITH EACH HANDHOLE.

NOT TO SCALE



RECOMMENDED:  
*[Signature]* 1-15-14  
DIVISION MANAGER DATE  
APPROVED:  
*[Signature]* 1/29/14  
PUBLIC WORKS DIRECTOR / DATE  
CITY ENGINEER

**CITY OF MORENO VALLEY**

PUBLIC WORKS DEPARTMENT - ELECTRIC UTILITY DIVISION

**17" x 30" x 24"  
PULL BOX  
FOR SERVICE CONNECTION**

STANDARD PLAN  
**MVEU-719-0**

SHEET 1 OF 1

MORENO VALLEY STANDARD NO. MVEU-720-0

10.5" x 17" x 24"

STREET LIGHT CONNECTION PULL BOX

(STREET LIGHT SYSTEM ONLY)

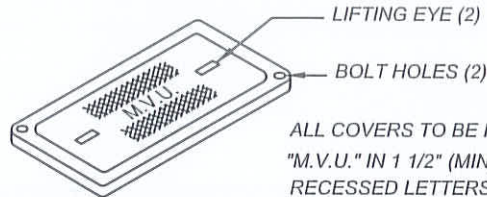

TYPICAL COVER

(PLASTIC OR CONCRETE IF IN SIDEWALK)

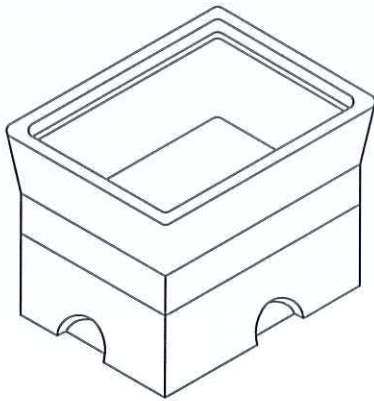

TYPICAL ASSEMBLY WITHOUT COVER

(PLASTIC OR CONCRETE IF IN SIDEWALK)

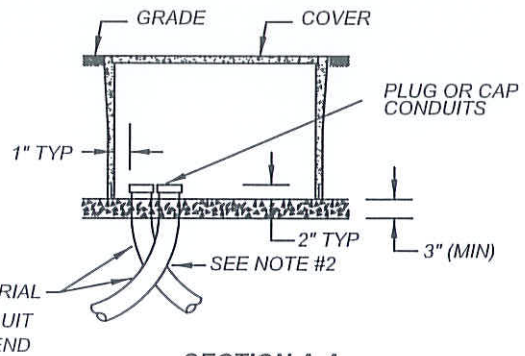

SECTION A-A

ALL CONDUITS



CONDUIT LOCATIONS

NOTES:

1. RADIUS ANGLE MAY BE REDUCED TO LESS THAN 90° PROVIDING THE PROJECTED CENTER LINE OF THE CONDUIT CLEARS HANDHOLE OPENING.
2. TWO HOLD DOWN DEVICES TO BE SUPPLIED WITH EACH HANDHOLE.

NOT TO SCALE

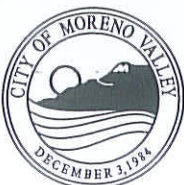

RECOMMENDED:  
 [Signature] 1-15-14  
 DIVISION MANAGER DATE  
 APPROVED:  
 [Signature] 1/29/14  
 PUBLIC WORKS DIRECTOR / DATE  
 CITY ENGINEER

**CITY OF MORENO VALLEY**

PUBLIC WORKS DEPARTMENT - ELECTRIC UTILITY DIVISION

**10.5" x 17" x 24"  
 PULL BOX  
 FOR STREET LIGHT CONNECTION**

STANDARD PLAN  
**MVEU-720-0**

SHEET 1 OF 1

MORENO VALLEY STANDARD NO. MVEU-721-0

**PRECAST CONCRETE PARKWAY ENCLOSURE**

**2' x 3' x 5' & 3' x 5' x 5'**

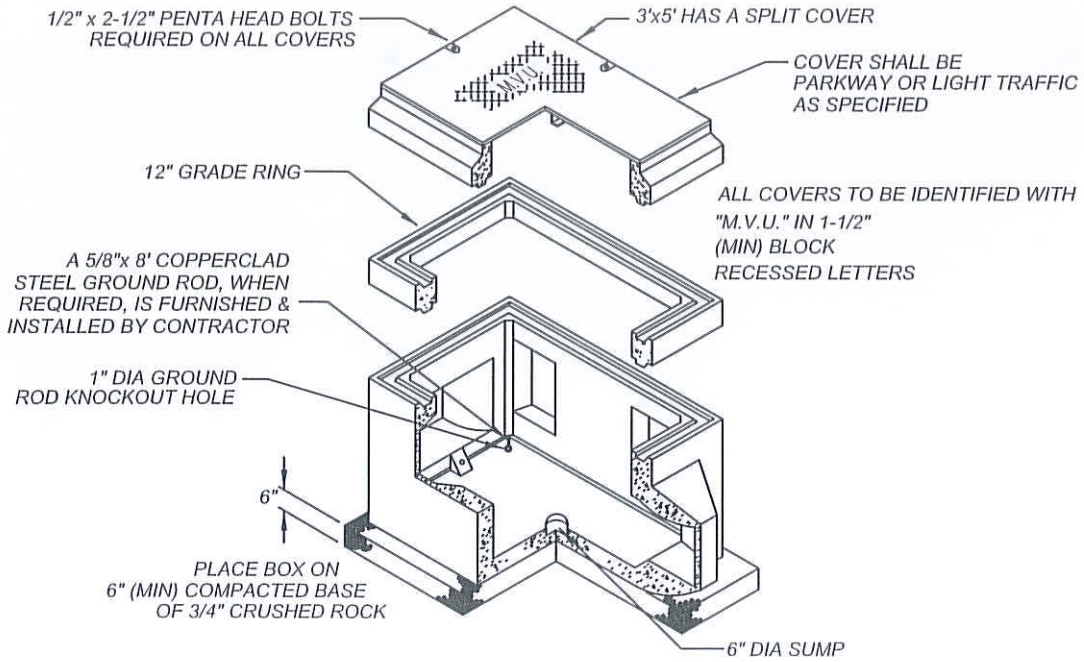

\* MIN EXCAVATION 36" x 72" x DEPTH OF BOX

**NOTES:**

1. USE A 2'x3'x5' FOR UP TO THREE (3) STRAIGHT SPLICES.
2. USE A 3'x5'x5' PULL BOX FOR UP TO THREE (3) JBAR SPLICES.

NOT TO SCALE

	RECOMMENDED:  1-15-10 DIVISION MANAGER      DATE	<b>CITY OF MORENO VALLEY</b> PUBLIC WORKS DEPARTMENT - ELECTRIC UTILITY DIVISION	
	APPROVED:  1/29/14 PUBLIC WORKS DIRECTOR / DATE CITY ENGINEER	<b>PRECAST CONCRETE                  PARKWAY ENCLOSURE</b> <b>2' x 3' x 5' AND 3' x 5' x 5'</b>	



MORENO VALLEY STANDARD NO. MVEU-722-0

**PROTECTIVE BARRIERS FOR EQUIPMENT AND STRUCTURES  
SUBJECT TO TRAFFIC LOCATIONS**

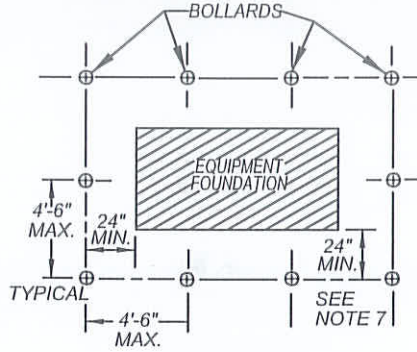

**PLAN VIEW**  
EQUIPMENT FOUNDATION

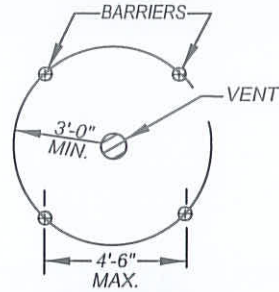

**PLAN VIEW**  
VAULT VENT PIPE

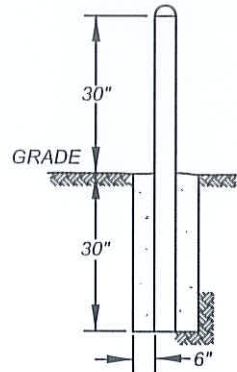

**ELEVATION VIEW**  
BOLLARD DETAIL

**BARRIER**

TO BE ONE OF THE FOLLOWING:

- 1) 4" GALV. STEEL PIPE (1/4" MIN. WALL) FILLED WITH CONCRETE
- 2) RAILROAD RAIL (90 LB. MIN.), or 51 14 75 AMERICAN STD. BEAM (5"x3"x1/2")
- 3) 8"x8" REINF. CONCRETE
- 4) SPECIAL BARRIERS BY PRIOR CITY APPROVAL

**NOTES:**

1. STRUCTURES WILL NORMALLY BE INSTALLED ONLY IN NON-TRAFFIC AREAS. BARRIERS TO BE USED WHEN EQUIPMENT IS LESS THAN 5' FROM TRAFFIC LANE (WITH CURB), 10' FROM TRAFFIC LANE (WITHOUT CURB), OR IN PARKING LOTS WHERE WITHIN 5' OF ANY VEHICULAR TRAFFIC AREA.
2. TOP OF BARRIERS TO BE SMOOTH CUT AND TOP EDGES TO BE ROUNDED.
3. ONE BARRIER TO BE REMOVABLE WHEN OVERHEAD OBSTACLES PREVENT EQUIPMENT REMOVAL BY CRANE.
4. ADEQUATE CLEARANCE MUST BE PROVIDED FOR DOORS, COOLING COILS, ETC.
5. BARRIERS, AS SHOWN, INDICATE TYPICAL REQUIREMENTS. FIELD CONDITIONS WILL NECESSITATE CHANGES FOR ADEQUATE EQUIPMENT PROTECTION. APPROVAL IN THE FIELD FROM THE UNDERGROUND INSPECTOR IS REQUIRED FOR ALL BARRICADE INSTALLATIONS.
6. WHEN SPECIFIED ON WORKING DRAWING, A 6" (MINIMUM HEIGHT) CURB MAY BE INSTALLED IN PLACE OF BARRIERS. THIS CURB MUST BE AT LEAST 6" THICK AND ITS FRONT FACE LOCATED 60" MINIMUM (OR AS SPECIFIED ON DRAWING) FROM THE EQUIPMENT FOUNDATION.
7. INCREASE TO 44" MINIMUM AT FRONT OF PADMOUNT 3 Ø TRANSFORMERS AND CAPACITORS, AND 36" MINIMUM AT BACK OF CAPACITORS (DOOR SIDE ONLY), WHEN A 72" x 94" PAD IS BEING INSTALLED.

NOT TO SCALE

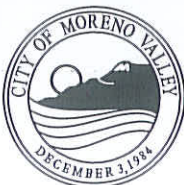

RECOMMENDED:  
*[Signature]* 1-5-14  
 DIVISION MANAGER DATE  
 APPROVED:  
*[Signature]* 1/29/14  
 PUBLIC WORKS DIRECTOR / DATE  
 CITY ENGINEER

**CITY OF MORENO VALLEY**

PUBLIC WORKS DEPARTMENT - ELECTRIC UTILITY DIVISION

**PROTECTIVE BARRIERS FOR  
EQUIPMENT AND STRUCTURES  
SUBJECT TO TRAFFIC LOCATIONS**

STANDARD PLAN  
**MVEU-722-0**

SHEET 1 OF 1



MORENO VALLEY STANDARD NO. MVEU-723-0

**RETAINING WALLS FOR  
PAD MOUNTED SWITCHES & TRANSFORMERS**

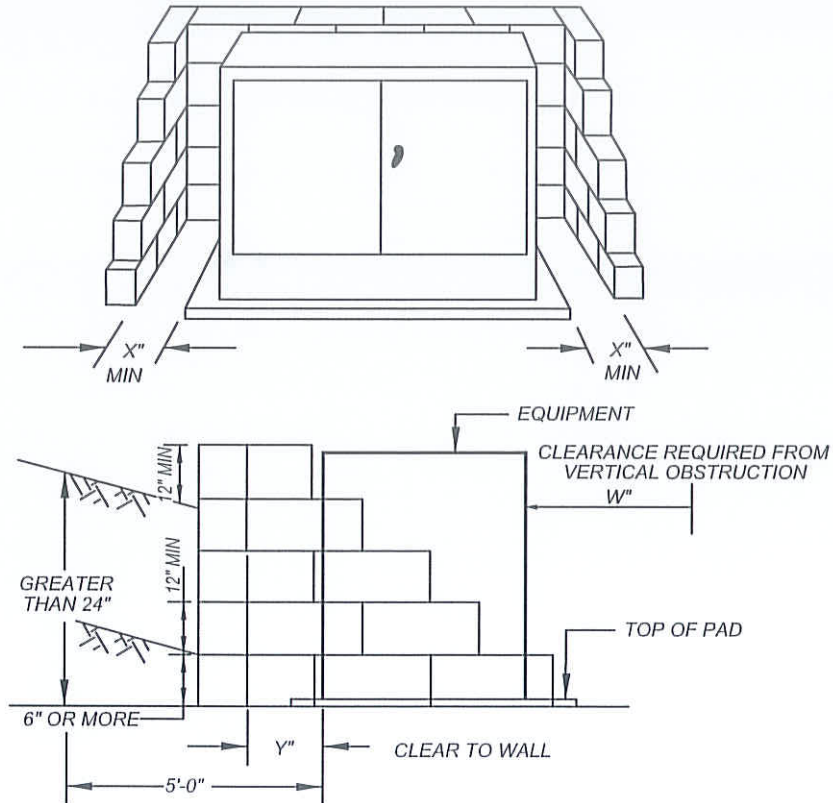

EQUIPMENT TYPE MINIMUM CLEARANCES	"W"	"X"	"Y"
TRANSFORMERS FRONT DOOR WORKING CLEARANCE	72"	---	---
TRANSFORMERS SIDE(S) CLEARANCE	---	18"	---
TRANSFORMERS REAR CLEARANCE	---	---	12"
SWITCHGEAR FRONT DOOR WORKING CLEARANCE	72"	---	---
SWITCHGEAR REAR DOORS WORKING CLEARANCE	---	---	72"
SWITCHGEAR SIDE(S) WORKING CLEARANCE	---	60"	---

**NOTES:**

1. RETAINING WALLS ARE REQUIRED WHERE A SLOPING GRADE RISES 24" OR MORE AT A HORIZONTAL DISTANCE OF 5' OR LESS FROM THE EDGE OF PAD OR ENCLOSURE.
2. RETAINING WALLS ARE ALSO REQUIRED WHENEVER THE GRADE RISES 6" ABOVE THE TOP OF PAD (SEE DRAWING DETAILS).
3. RETAINING WALLS MUST BE APPROVED BY BUILDING DEPARTMENT AND REQUIRES A SEPARATE PERMIT(S) . SEE STANDARD MVGF-650A-0 AND MVGF-650B-0.

NOT TO SCALE

	RECOMMENDED: <i>[Signature]</i> 1-15-14 DIVISION MANAGER DATE	<b>CITY OF MORENO VALLEY</b> PUBLIC WORKS DEPARTMENT - ELECTRIC UTILITY DIVISION	
	APPROVED: <i>[Signature]</i> 1/29/14 PUBLIC WORKS DIRECTOR / DATE CITY ENGINEER	<b>RETAINING WALLS FOR PAD-MOUNTED SWITCHES &amp; TRANSFORMERS</b>	

MORENO VALLEY STANDARD No MVEU-724A

**TRENCH DETAILS FOR  
CONDUIT INSTALLATIONS**

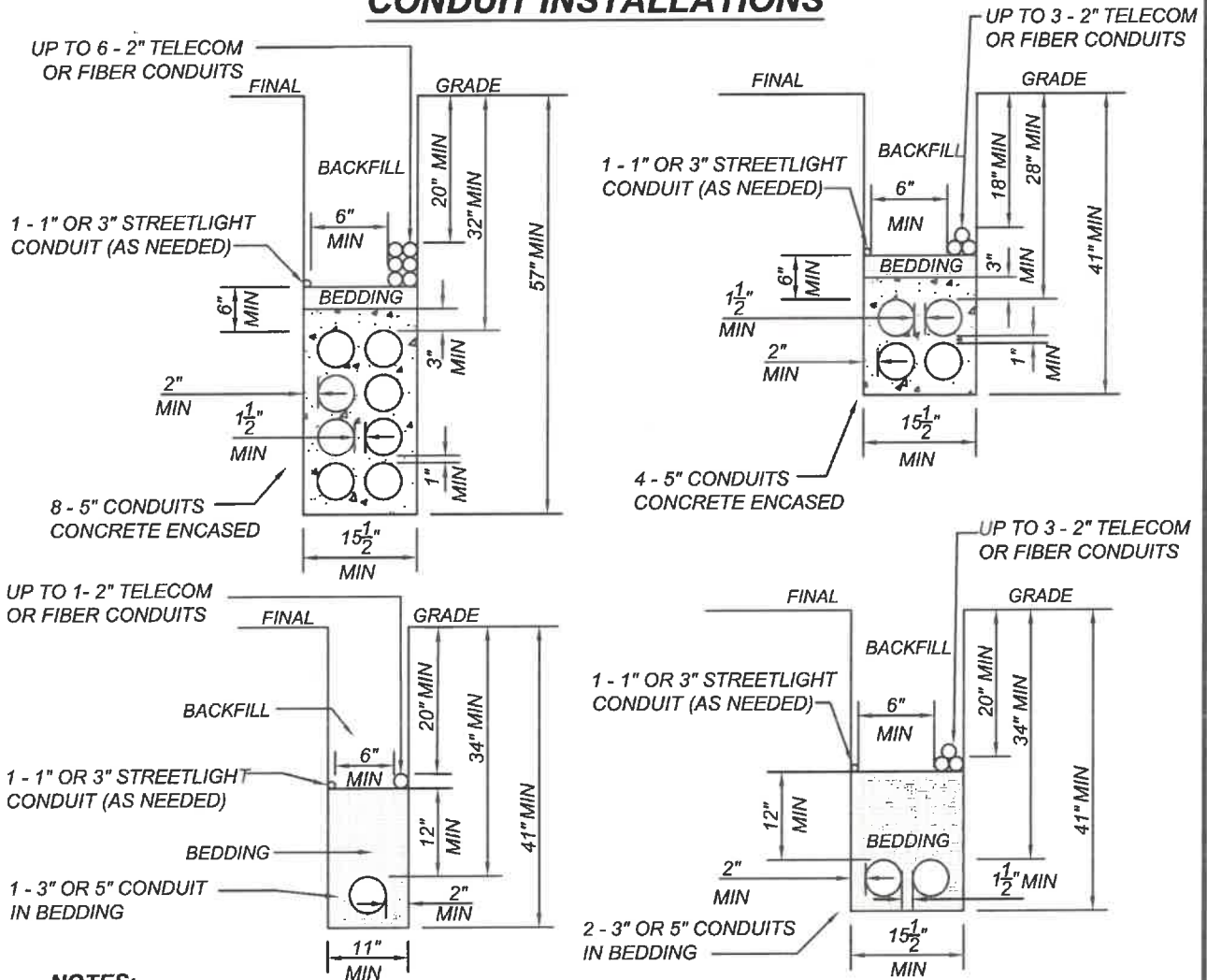

**NOTES:**

- 1.) BEDDING MATERIAL SHALL BE CLEAN SAND OR PEA GRAVEL. OTHERWISE, NATIVE MATERIALS MAY BE USED PROVIDED THEY MEET PUBLIC WORKS CONSTRUCTION (GREEN BOOK) STANDARDS PER SUBSECTION 306.1.2.1 AND MUST HAVE A SAND EQUIVALENT OF NOT LESS THAN 30 OR HAVING A COEFFICIENT OF PERMEABILITY GREATER THAN 1.4 INCHES/HR.
- 2.) ALL CONDUITS AND CONDUIT ELBOWS SHALL BE SCH-40, SCH-80, OR FIBERGLASS.
- 3.) FOR CONDUIT INSTALLATION IN A BORE, SEE STD PLANS MVEU-727A & MVEU-727B.
- 4.) FOR CONDUIT INSTALLATION IN EXISTING ROADWAYS, SEE STD PLANS MVS1-132A, MVS1-132B, & MVS1-132C FOR SURFACE RESTORATION AND BACKFILL REQUIREMENTS.
- 5.) CONCRETE SHALL BE TWO SACK ENCASEMENT
- 6.) ORANGE INSULATED COPPER GLAD STEEL TRACER WIRE PER KRISTECH SPECIFICATIONS SHEET, OR EQUAL. TRACER WIRE TO BE INSTALLED 2" ABOVE COMMUNICATION CONDUIT PER "THE COMPLETE UTILITY LOCATING SYSTEM SPECIFICATIONS FOR TELECOMMUNICATIONS" BY COPPERHEAD INDUSTRIES, OR EQUIVALENT.

NOT TO SCALE



RECOMMENDED:  
*pautilter* 6-21-23  
DIVISION MANAGER DATE

APPROVED:  
*M. Williams* 6/21/23  
PUBLIC WORKS DIRECTOR / DATE  
CITY ENGINEER

**CITY OF MORENO VALLEY**

PUBLIC WORKS DEPARTMENT - ELECTRIC UTILITY DIVISION

**TRENCH DETAILS  
FOR  
CONDUIT INSTALLATIONS**

STANDARD PLAN  
**MVEU-724A-2**

SHEET 1 OF 2

MORENO VALLEY STANDARD No MVEU-724B

**TRENCH DETAILS FOR  
CONDUIT INSTALLATIONS JOINT WITH GAS**

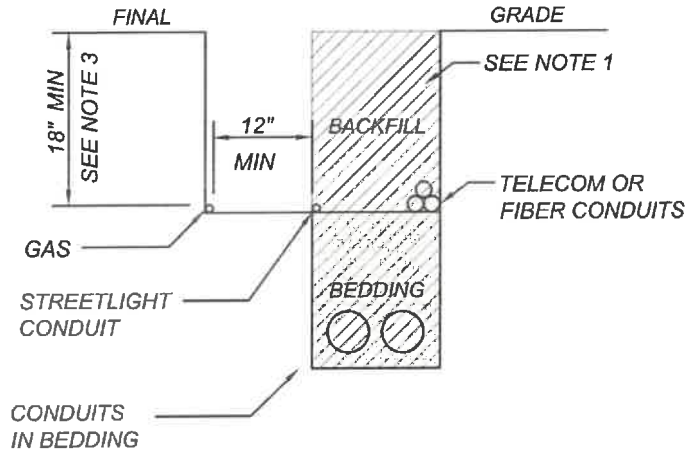

**NOTES:**

- 1.) SEE MVEU-724A FOR MINIMUM DEPTHS AND CLEARANCES FOR COMMUNICATION AND POWER CONDUIT CONFIGURATIONS.
- 2.) GAS LINES IN THE JOINT TRENCH SHALL BE STEPPED OUT HORIZONTALLY AT LEAST 12" FROM COMMUNICATION OR POWER CONDUITS.
- 3.) THE MINIMUM DEPTH OF THE GAS LINE SHALL BE AT LEAST 18" FROM FINAL GRADE, OR AS DETERMINED FROM THE LOCAL GAS PURVEYOR'S STANDARDS, WHICHEVER IS DEEPER.
- 4.) BEDDING MATERIAL SHALL BE CLEAN SAND OR PEA GRAVEL. OTHERWISE, NATIVE MATERIALS MAY BE USED PROVIDED THEY MEET PUBLIC WORKS CONSTRUCTION (GREEN BOOK) STANDARDS PER SUBSECTION 306.1.2.1 AND MUST HAVE A SAND EQUIVALENT OF NOT LESS THAN 30 OR HAVING A COEFFICIENT OF PERMEABILITY GREATER THAN 1.4 INCHES/HR.
- 5.) CONDUITS AND CONDUIT ELBOWS SHALL BE SCH-40, SCH-80, OR FIBERGLASS.
- 6.) FOR CONDUIT INSTALLATION IN A BORE, SEE STD PLANS MVEU-727A & MVEU-727B.
- 7.) FOR CONDUIT INSTALLATION IN EXISTING ROADWAYS, SEE STD PLANS MVSI-132A, MVSI-132B, & MVSI-132C FOR SURFACE RESTORATION AND BACKFILL REQUIREMENTS.
- 8.) CONCRETE SHALL BE TWO SACK ENCASEMENT.
- 9.) ORANGE INSULATED COPPER CLAD STEEL TRACER WIRE PER KRISTECH SPECIFICATIONS SHEET, OR EQUAL. TRACER WIRE TO BE INSTALLED 2" ABOVE COMMUNICATION CONDUIT PER "THE COMPLETE UTILITY LOCATING SYSTEM SPECIFICATIONS FOR TELECOMMUNICATIONS" BY COPPERHEAD INDUSTRIES, OR EQUIVALENT.

NOT TO SCALE

	RECOMMENDED: <i>J. J. J. 6-21</i> DIVISION MANAGER      DATE <i>23</i>	<b>CITY OF MORENO VALLEY</b> PUBLIC WORKS DEPARTMENT - ELECTRIC UTILITY DIVISION	
	APPROVED: <i>[Signature]</i> 6/21/23 PUBLIC WORKS DIRECTOR / DATE CITY ENGINEER	<b>TRENCH DETAILS FOR CONDUIT INSTALLATIONS JOINT WITH GAS</b>	



MORENO VALLEY STANDARD NO. MVEU-725-0

**PRECAST SURFACE OPERABLE PARKWAY ENCLOSURE**  
**(5' x 8'-6" x 5')**

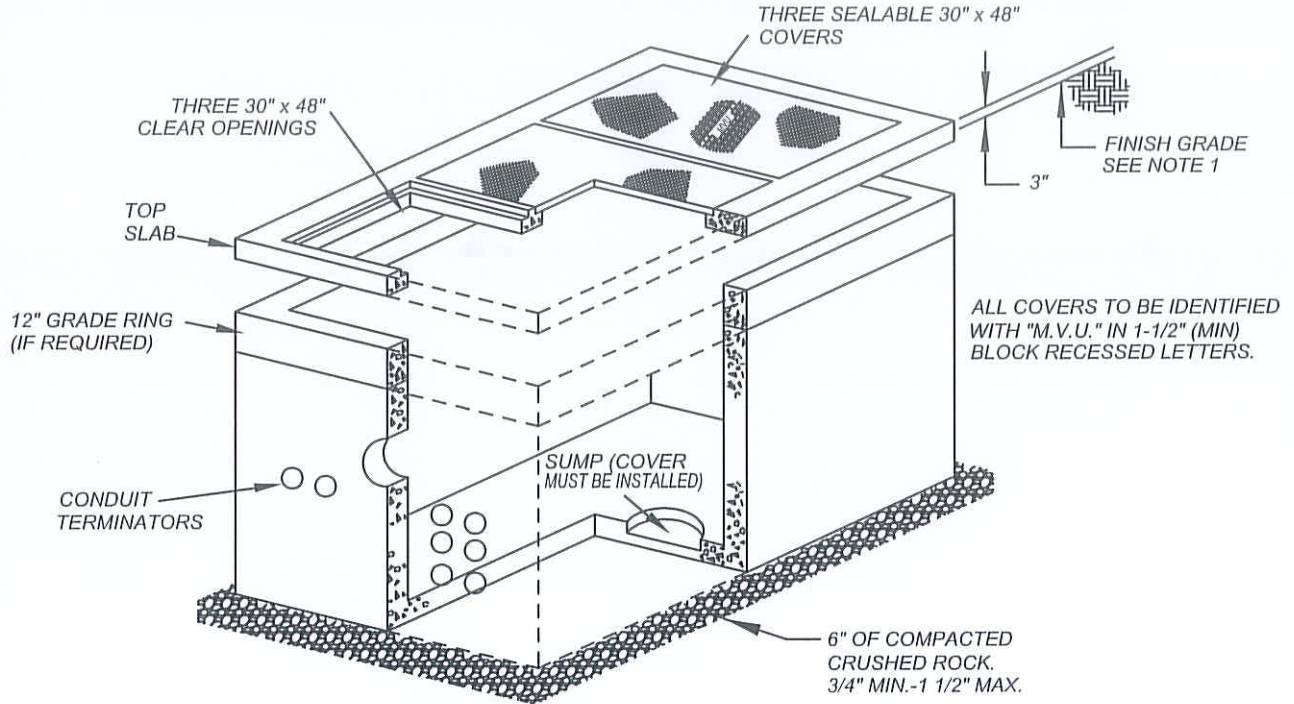

EXCAVATION SIZE:  
 CONSULT MANUFACTURERS' GUIDES FOR EXACT EXCAVATION DIMENSION

**NOTES:**

- 1.) TOP SURFACE OF ENCLOSURE SLAB SHALL BE SET 3" ABOVE FINISH GRADE WHEN INSTALLED IN A LANDSCAPED AREA.
- 2.) ENCLOSURE SHALL BE FURNISHED WITH 1/2" THREADED BRONZE GROUNDING INSERTS.
- 3.) INSIDE WALLS ARE TO BE PAINTED WHITE.
- 4.) ENCLOSURE PROVIDED WITH THREE HOT-DIPPED GALVANIZED 30"x 48" STEEL PULL BOX FRAMES. A ONE PIECE EPDM GASKET SHALL BE PERMANENTLY GLUED IN PLACE TO EACH FRAME.
- 5.) THREE 30"x 48" POLYMER CONCRETE PARKWAY COVERS SHALL BE FLAT AND SMOOTH WITH NO SURFACE POCKETS FOR A MINIMUM OF 2" BACK FROM THE OUTER PERIMETER OF COVER.
- 6.) ENCLOSURE TO BE INSTALLED WITH PRIMARY GROUND ASSEMBLY.
- 7.) 13" DIA x 12" DIA SUMP x 4-1/2" DEEP WITH COVER, LOCATE AS FOLLOWS: BOTTOM SECTION (1) CORE MTD.
- 8.) ENCLOSURE TO BE INSTALLED WITH CABLE RACK ASSEMBLY.
- 9.) PRIMARY GROUND HALO TO BE #4 /O BC AND ATTACHED TO ALL GROUND INSERTS.

NOT TO SCALE

	RECOMMENDED: <i>[Signature]</i> 1-22-14 DIVISION MANAGER      DATE	<b>CITY OF MORENO VALLEY</b> PUBLIC WORKS DEPARTMENT - ELECTRIC UTILITY DIVISION	STANDARD PLAN
	APPROVED: <i>[Signature]</i> 1/29/14 PUBLIC WORKS DIRECTOR/      DATE CITY ENGINEER	<b>SURFACE OPERABLE ENCLOSURE</b> <b>5' x 8'-6" x 5'</b>	<b>MVEU-725-0</b>



MORENO VALLEY STANDARD NO. MVEU-726-0

**PRECAST VAULT ENCLOSURE**

**6' x 12' x 7'**

ALL COVERS TO BE IDENTIFIED WITH  
"M.V.U." IN 1-1/2" (MIN) BLOCK  
RECESSED LETTERS.

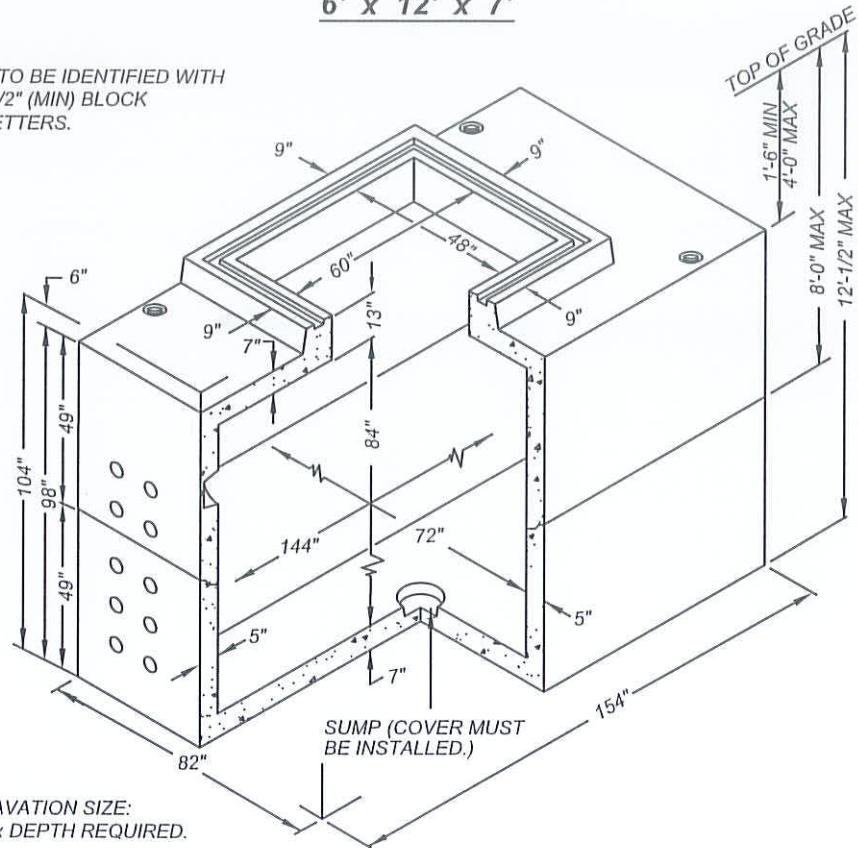

MINIMUM EXCAVATION SIZE:  
7'-10" x 13'-10" x DEPTH REQUIRED.

**NOTES:**

- 1.) VAULT DESIGNED IN ACCORDANCE WITH AASHTO H-20-44 TRAFFIC BRIDGE LOADING USING 5,500 PSI COMPRESSIVE STRENGTH CONCRETE AND 60,000 PSI YIELD STRENGTH ASTM A-706 STEEL REINFORCEMENT.
- 2.) VAULT TO BE PLACED ON A MIN 6" BASE OF CRUSHER RUN FOR EASE OF INSTALLATION AND EVEN LOAD DISTRIBUTION.
- 3.) LIMIT OF COVER OVER ROOF SECTION IS 1'-6" TO 4'-0".
- 4.) LIMIT OF EMBEDMENT OF BOTTOM SECTION IS 10'-8" TO 13'-2".
- 5.) ALL WALLS AND CEILINGS TO BE PAINTED WITH WHITE PAINT.
- 6.) STEEL LADDER TO BE SUPPLIED WITH EACH VAULT.
- 7.) ADJUST TO GRADE WITH GRADE RINGS.
- 8.) ENCLOSURE TO BE INSTALLED WITH PRIMARY GROUND ASSEMBLY.
- 9.) 13" DIA x 12" DIA SUMP x 4-1/2" DEEP WITH COVER, LOCATE AS FOLLOWS: BOTTOM OF SECTION (1) CORE MTD.
- 10.) ENCLOSURE TO BE INSTALLED WITH CABLE RACK ASSEMBLY
- 11.) PRIMARY GROUND HALO TO BE #4 /O BC AND ATTACHED TO ALL GROUND INSERTS.

NOT TO SCALE

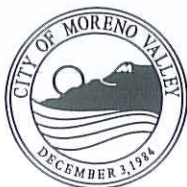

RECOMMENDED:  
*[Signature]* 1-15-14  
DIVISION MANAGER DATE

APPROVED:  
*[Signature]* 1/29/14  
PUBLIC WORKS DIRECTOR / DATE  
CITY ENGINEER

**CITY OF MORENO VALLEY**  
PUBLIC WORKS DEPARTMENT - ELECTRIC UTILITY DIVISION

**VAULT**  
**6' x 12' x 7'**

STANDARD PLAN  
**MVEU-726-0**

SHEET 1 OF 1

MORENO VALLEY STANDARD NO. MVEU-727A-0

**CONDUIT BANK REQUIREMENTS**  
**INSTALLATION IN A BORE**

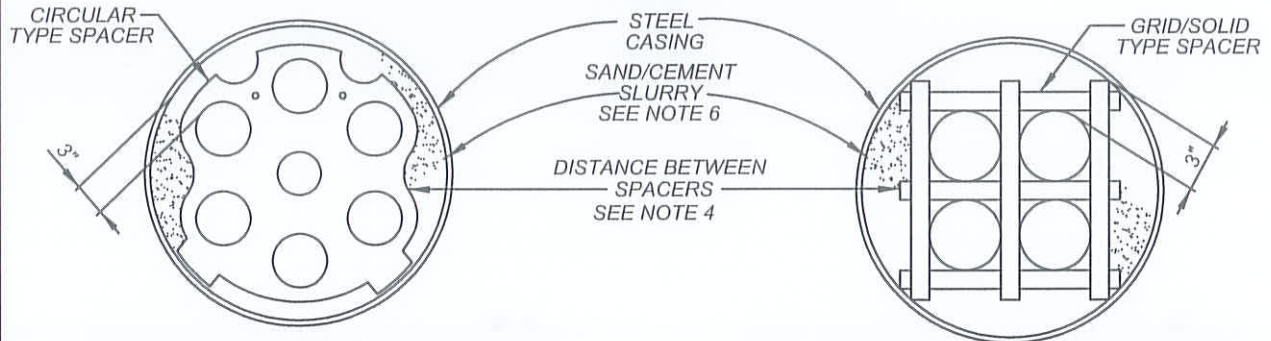

**METHOD A CIRCULAR SPACER**  
**FOR RIGID SCH. 40 PVC CONDUIT**

**METHOD B GRID/SOLID SPACER**  
**FOR RIGID SCH. 40 PVC CONDUIT**



**CONDUIT BANK REQUIREMENT- INSTALLATION IN A BORE**

METHOD	NO. OF 5" CONDUITS	RECOMMENDED CASING SIZE	METHOD	NO. OF 5" CONDUITS	RECOMMENDED CASING SIZE
-	-	-	B	4	20" OD
A	6	22" OD	B	6	28" OD
A	8	28" OD	B	8	32" OD
-	-	-	B	10	38" OD
-	-	-	B	12	44" OD

**NOTES:**

- 1.) INSTALLATION SHALL BE MADE BY MACHINE BORING OR BY JACKING. SLUICING AND JETTING WITH WATER IS NOT PERMITTED. A LIMITED USE OF WATER FOR LUBRICATION OF DRILLS MAY BE PERMITTED, HOWEVER, BY SPECIAL ARRANGEMENT WITH THE CITY ENGINEER.
- 2.) A NEW STEEL CASING WILL NORMALLY BE USED. USED CASING, WHICH SHOWS LITTLE OR NO DETERIORATION, MAY BE USED IF JUDGED SATISFACTORY BY THE CITY ENGINEER. THE MINIMUM ALLOWABLE THICKNESS IS 1/4". USE A 1/4" WALL THICKNESS IF UNDER 30" IN DIAMETER; A 3/8" WALL THICKNESS FOR DIAMETERS UP TO 48" AND A 1/2" THICKNESS FOR DIAMETERS 42" AND GREATER. THE TYPE OF CONSTRUCTION SHOULD GOVERN THE WALL THICKNESS. THE CONTRACTOR SHALL BE SOLELY RESPONSIBLE FOR THE SUFFICIENCY OF THE CASING DURING CONSTRUCTION, AND ALSO THE METHOD OF INSTALLATION.
- 3.) CONDUITS INSTALLED IN THE CASING AS IN "METHOD A" OR "METHOD B" ABOVE SHALL BE RIGID SCH. 40 PVC.
- 4.) SPACERS SHALL BE OF THE TYPE AND DESIGN AS APPROVED BY THE CITY ENGINEER. SPACERS SHALL BE INSTALLED AND MAINTAINED IN A VERTICAL POSITION, AND THE DISTANCE BETWEEN SPACERS SHALL BE LIMITED TO A MAXIMUM OF FIVE FEET.
- 5.) THE INSTALLATION OF FOREIGN UTILITIES IN BORE CASINGS IS NOT PERMITTED.
- 6.) CONDUITS SHALL MAINTAIN THE SAME POSITION ENTERING AND LEAVING THE CASING. AFTER THE CONDUITS ARE IN PLACE, A SAND/ CEMENT SLURRY (MINIMUM OF ONE SACK OF CEMENT PER CUBIC YARD) AND VIBRATORS SHALL BE USED TO MINIMIZE VOIDS.
- 7.) WHEN SPECIFIED ON WORKING DRAWING, CONTRACTOR SHALL INSTALL INSULATED COPPER NEUTRAL WIRE IN CASING PER SEPARATE PLAN.
- 8.) THE CALIFORNIA DIVISION OF INDUSTRIAL SAFETY, MINING AND TUNNELING UNIT SHALL BE NOTIFIED BY THE CONTRACTOR AND AN UNDERGROUND CLASSIFICATION PERMIT BE ISSUED PRIOR TO THE INSTALLATION OF ANY BORE CASING 30" IN DIAMETER OR LARGER.

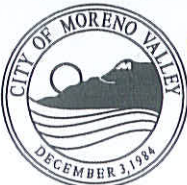
NOT TO SCALE

 <p>CITY OF MORENO VALLEY DECEMBER 3, 1984</p>	RECOMMENDED:  DIVISION MANAGER      DATE 1-22-14	<h2>CITY OF MORENO VALLEY</h2> PUBLIC WORKS DEPARTMENT - ELECTRIC UTILITY DIVISION	
	APPROVED:  PUBLIC WORKS DIRECTOR/ CITY ENGINEER      DATE 1/29/14	<h3>CONDUIT BANK REQUIREMENTS</h3> <h3>INSTALLATION IN A BORE</h3>	



MORENO VALLEY STANDARD No MVEU-727B-0

**CONDUIT SPACERS METHOD B**

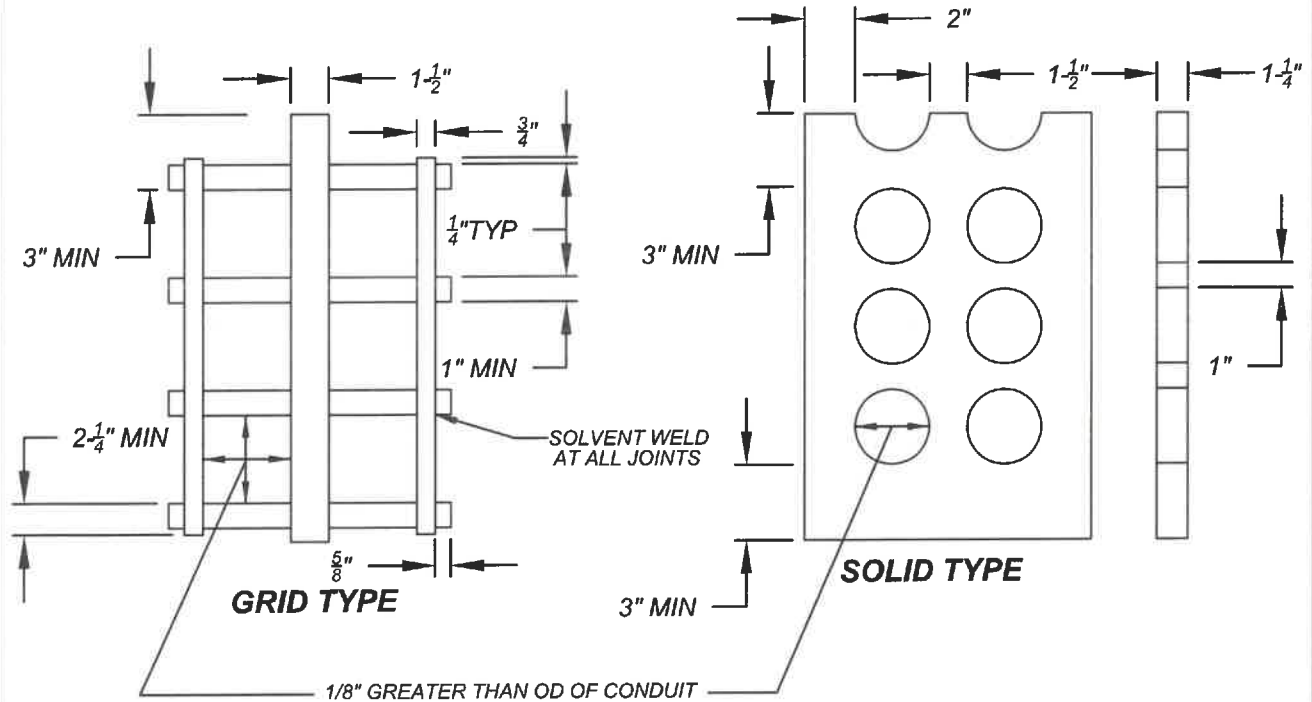

**NOTES:**

- 1.) MATERIAL:
  - A. GRID-TYPE SPACER TO BE FABRICATED TO PLASTIC CONDUIT WITH MINIMUM WALL THICKNESS OF 0.09 INCHES.
  - B. SOLID-TYPE SPACER TO BE FORMED OF POLYURETHANE WITH A MINIMUM DENSITY OF 4lb/cf.
- 2.) TIERS MAY BE ADDED OR DELETED AS REQUIRED. CLEARANCE AS SHOWN MUST BE MAINTAINED BETWEEN CONDUITS.
- 3.) FOR FULL ENCASEMENT IN A TRENCH, A THREE-INCH MINIMUM CLEARANCE BETWEEN THE TRENCH BOTTOM AND THE LOWER TIER OF DUCTS SHALL BE MAINTAINED. TO MEET THIS REQUIREMENT, THE GRID-TYPE SPACER MUST BE SET UPON A BASE OF SUCH THICKNESS TO PROVIDE THREE INCHES OF CLEARANCE. THE SPACERS SHALL BE ANCHORED TO THE GROUND TO AVOID FLOATING DURING PLACEMENT OF SAND/CEMENT SLURRY.
- 4.) FOR TRENCH DETAILS FOR CONDUIT INSTALLATIONS, SEE STD PLAN MVEU-724A & MVEU-724B.

NOT TO SCALE

	RECOMMENDED: <i>[Signature]</i> 12-27-2021 DIVISION MANAGER DATE	<b>CITY OF MORENO VALLEY</b> FINANCIAL & MANAGEMENT SERVICES DEPARTMENT - ELECTRIC UTILITY DIVISION		
	APPROVED: <i>[Signature]</i> 2/4/22 PUBLIC WORKS DIRECTOR / DATE CITY ENGINEER	<b>CONDUIT BANK REQUIREMENTS MVEU-727B-0</b>		STANDARD PLAN
				SHEET 2 OF 2

**MORENO VALLEY STANDARD No MVEU-728A-0**

**5' x 10'-6" x 7' MANHOLE**

ALL COVERS TO BE IDENTIFIED WITH  
"M.V.U." IN 1 1/2" (MIN) BLOCK  
RECESSED LETTERS.

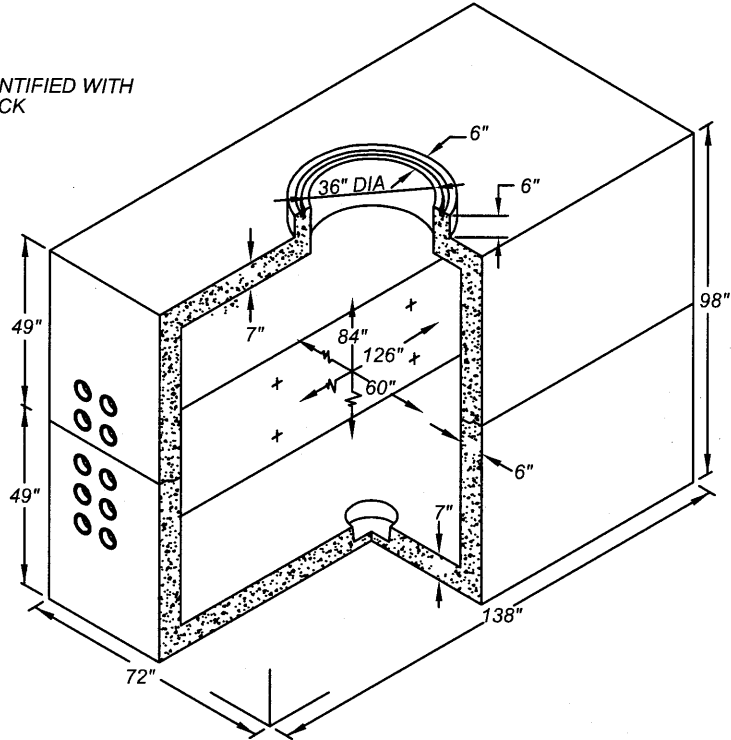



MINIMUM EXCAVATION SIZE:  
7'-10" x 12'-10" x DEPTH REQUIRED.

**NOTES:**

1. MANHOLE DESIGNED IN ACCORDANCE WITH AASHTO H-20-44 TRAFFIC BRIDGE LOADING USING 5,500 PSI CONCRETE COMPRESSIVE STRENGTH AND 60,000 PSI YIELD STRENGTH ASTM A-706 STEEL REINFORCEMENT.
2. MANHOLE TO BE PLACED ON A MIN 6" CRUSHER RUN FOR EASE OF INSTALLATION AND EVEN LOAD DISTRIBUTION.
3. LIMIT OF COVER OVER TOP SECTION IS 1'-6" TO 4'-0".
4. 13" DIA x 12" DIA SUMP x 4 1/2" DEEP WITH COVER, LOCATE AS FOLLOWS: BOTTOM OF SECTION (1) CORE MTD.
5. INSIDE WALL AND CEILING TO BE PAINTED WHITE.
6. TAMP EXCAVATION FLOOR.
7. ADJUST TO GRADE WITH GRADE RINGS.
8. PRIMARY GROUND HALO TO BE #4 /O BC AND ATTACHED TO ALL GROUND INSERTS.

NOT TO SCALE

	RECOMMENDED:  12-27-16 DIVISION MANAGER      DATE	<h2 style="margin: 0;">CITY OF MORENO VALLEY</h2> <p style="margin: 0;">PUBLIC WORKS DEPARTMENT - ELECTRIC UTILITY DIVISION</p>	
	APPROVED:  1/20/17 PUBLIC WORKS DIRECTOR / DATE CITY ENGINEER	<h3 style="margin: 0;">MANHOLE</h3> <h3 style="margin: 0;">5' x 10'-6" x 7'</h3>	



**MORENO VALLEY STANDARD No MVEU-728B-0**

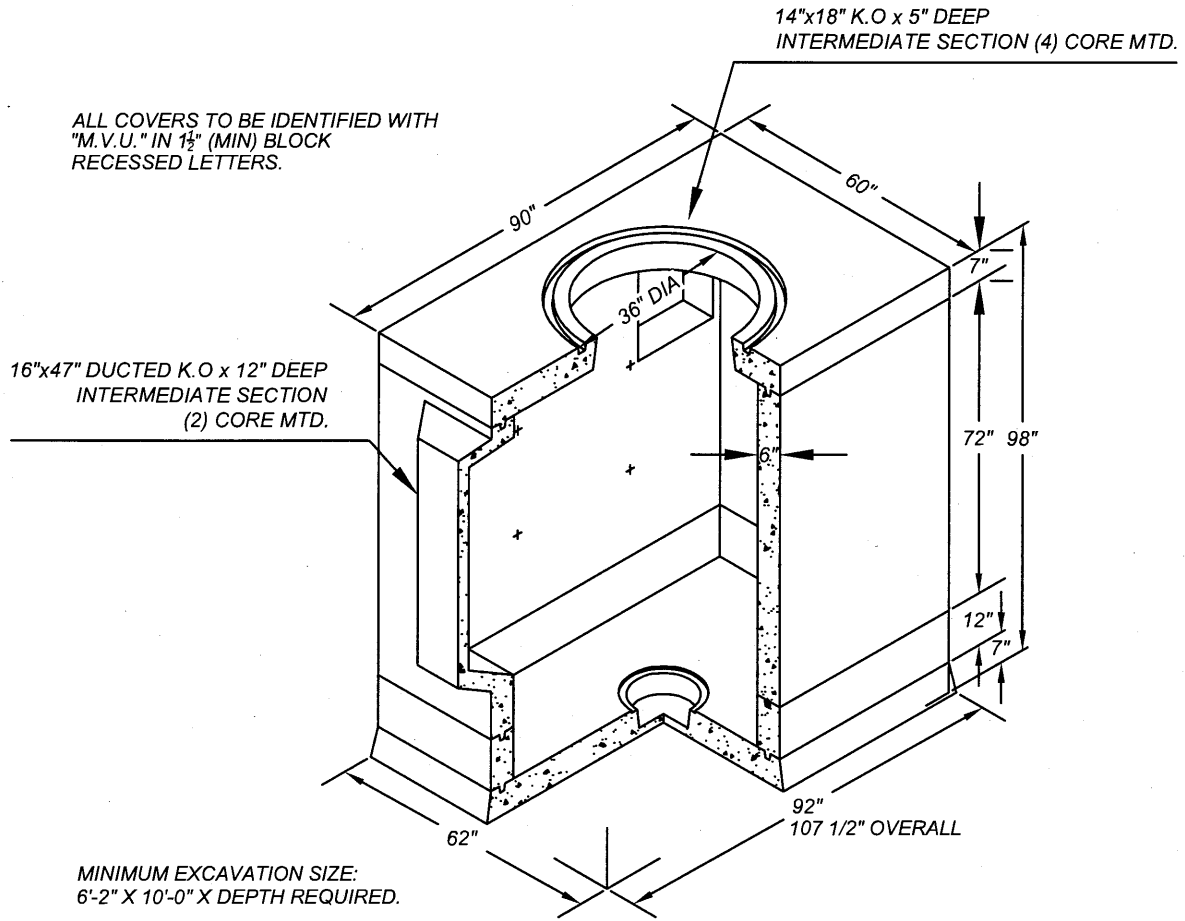

**4' x 6'-6" x 7' MANHOLE**



**NOTES:**

1. MANHOLE DESIGNED IN ACCORDANCE WITH AASHTO H-20-44 TRAFFIC BRIDGE LOADING USING 5,500 PSI CONCRETE COMPRESSIVE STRENGTH AND 60,000 PSI YIELD STRENGTH ASTM A-706 STEEL REINFORCEMENT.
2. MANHOLE TO BE PLACED ON A MIN. 6" CRUSHER RUN FOR EASE OF INSTALLATION AND EVEN LOAD DISTRIBUTION.
3. LIMIT OF COVER OVER TOP SECTION IS 1'-6" TO 4'-0".
4. 13" DIA x 14" DIA SUMP x 5" DEEP WITH RECESS, LOCATE AS FOLLOWS: BASE SLAB (1) TABLE MTD.
5. INSIDE WALL AND CEILING TO BE PAINTED WHITE.
6. TAMP EXCAVATION FLOOR.
7. ADJUST TO GRADE WITH GRADE RINGS.
8. PRIMARY GROUND HALO TO BE #4 /O BC AND ATTACHED TO ALL GROUND INSERTS.

NOT TO SCALE

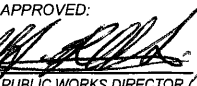
	RECOMMENDED: 	12-27-16 DATE	<h2 style="margin: 0;">CITY OF MORENO VALLEY</h2> PUBLIC WORKS DEPARTMENT - ELECTRIC UTILITY DIVISION
	DIVISION MANAGER	APPROVED: 	1/20/17 DATE
	PUBLIC WORKS DIRECTOR / CITY ENGINEER		STANDARD PLAN <h3 style="margin: 0;">MVEU-728B-0</h3> SHEET 2 OF 2



# City of Moreno Valley Electric Utility

## Electrical Distribution Project

Project Description  
and Limits

Start - Completion Date

City Council:  
<Name>, Mayor  
<Name>, Mayor Pro Tem  
<Name Only>  
<Name Only>  
<Name Only>

Moreno Valley Public Works  
951.413.3500  
www.moval.org

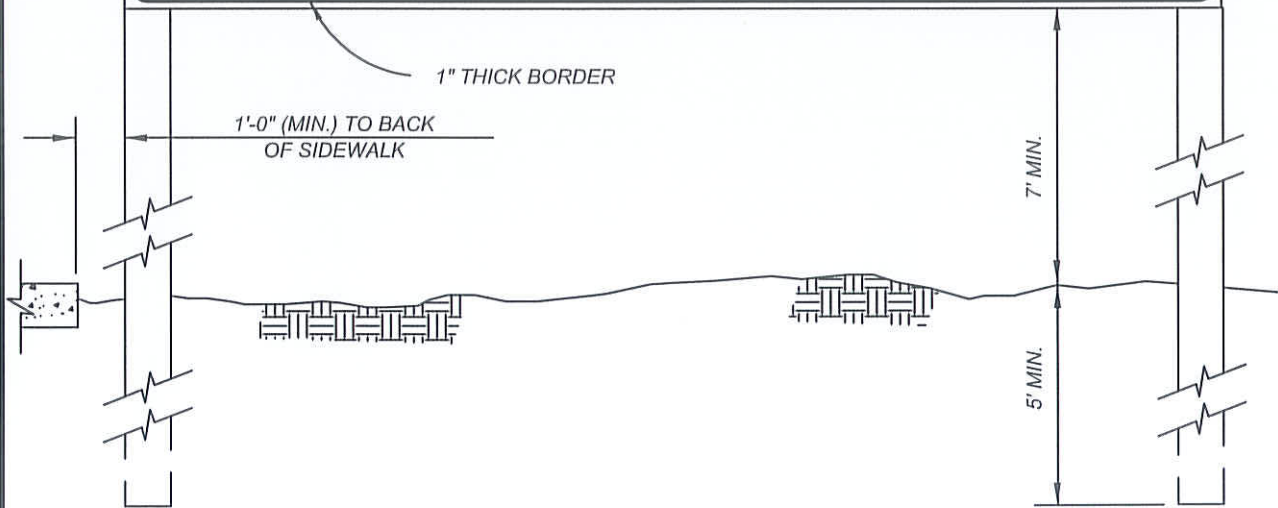



### NOTES:

- 1.) SIGNS SHALL BE SECURELY MOUNTED ON (2) 4" x 4" POSTS.
- 2.) OUTSIDE DIMENSIONS SHALL BE 4' x 8'.
- 3.) LETTERS AND BORDER SHALL BE BLACK ON WHITE BACKGROUND.
- 4.) ENGINEER TO PROVIDE PROJECT DESCRIPTION, LIMITS, NAMES OF CURRENT CITY COUNCIL MEMBERS AND GRAPHICS.
- 5.) CITY CAN PROVIDE "PROOF" LAYOUT IN DIGITAL FORMAT.
- 6.) CONTRACTOR / DEVELOPER TO PROVIDE FINAL "PROOF" ON 11" x 17" PAPER FROM VENDOR FOR CITY APPROVAL PRIOR TO MANUFACTURING THE SIGN.
- 7.) CONTRACTOR / DEVELOPER TO PROVIDE PHOTOGRAPH OF ACTUAL 4' x 8' SIGN FOR CITY APPROVAL PRIOR TO INSTALLATION.

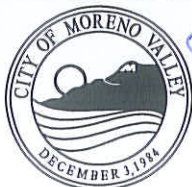
NOT TO SCALE



RECOMMENDED:  
 1-22-14  
 DIVISION MANAGER DATE  
 APPROVED:  
 1/29/14  
 PUBLIC WORKS DIRECTOR / DATE  
 CITY ENGINEER

CITY OF MORENO VALLEY  
PUBLIC WORKS DEPARTMENT - ELECTRIC UTILITY DIVISION

**PROJECT SIGN  
ELECTRICAL DISTRIBUTION  
PROJECT**

STANDARD PLAN  
**MVEU-729A-0**  
SHEET 1 OF 2



City of Moreno Valley Electric Utility

# Project Completion

## Electrical Distribution Project

### Thank you for your cooperation

City Council:  
<Name>, Mayor  
<Name>, Mayor Pro Tem  
<Name Only>  
<Name Only>  
<Name Only>

Moreno Valley Public Works  
951.413.3500  
www.moval.org

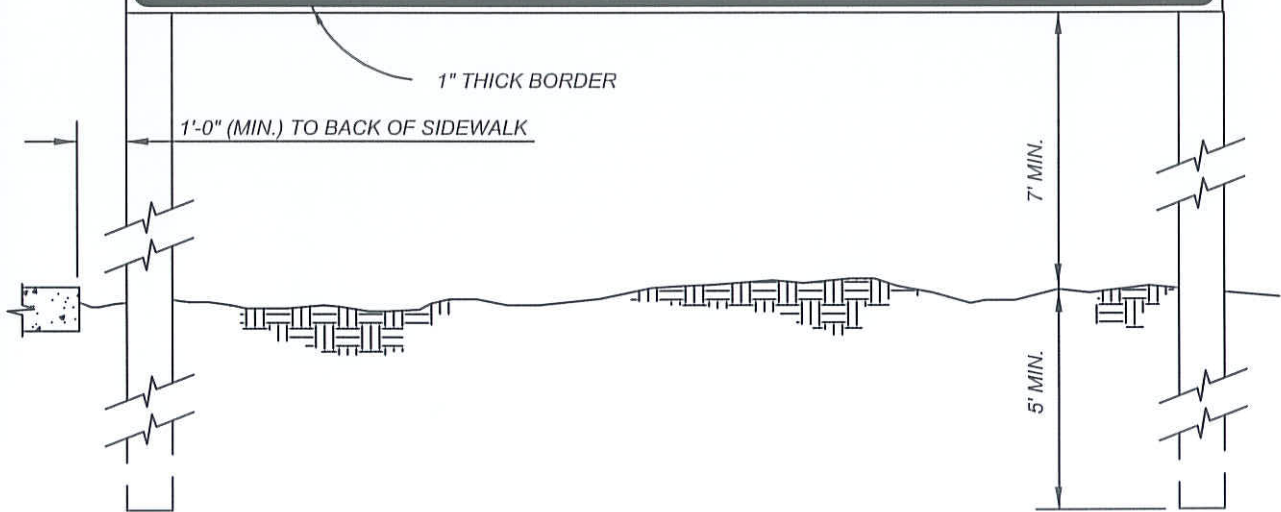



#### NOTES:

- 1.) SIGNS SHALL BE SECURELY MOUNTED ON (2) 4" x 4" POSTS.
- 2.) OUTSIDE DIMENSIONS SHALL BE 4' x 8'.
- 3.) LETTERS AND BORDER SHALL BE BLACK ON WHITE BACKGROUND.
- 4.) ENGINEER TO PROVIDE PROJECT DESCRIPTION, LIMITS, NAMES OF CURRENT CITY COUNCIL MEMBERS AND GRAPHICS.
- 5.) CITY CAN PROVIDE "PROOF" LAYOUT IN DIGITAL FORMAT.
- 6.) CONTRACTOR / DEVELOPER TO PROVIDE FINAL "PROOF" ON 11" x 17" PAPER FROM VENDOR FOR CITY APPROVAL PRIOR TO MANUFACTURING THE SIGN.
- 7.) CONTRACTOR / DEVELOPER TO PROVIDE PHOTOGRAPH OF ACTUAL 4' x 8' SIGN FOR CITY APPROVAL PRIOR TO INSTALLATION.

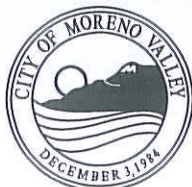
NOT TO SCALE



RECOMMENDED:  
  
 DIVISION MANAGER DATE  
 APPROVED:  
  
 PUBLIC WORKS DIRECTOR/ DATE  
 CITY ENGINEER

## CITY OF MORENO VALLEY

PUBLIC WORKS DEPARTMENT - ELECTRIC UTILITY DIVISION

### PROJECT COMPLETION SIGN ELECTRICAL DISTRIBUTION PROJECT

STANDARD PLAN  
**MVEU-729B-0**  
SHEET 2 OF 2

MORENO VALLEY STANDARD No MVEU-730A-0

PRECAST VAULT ENCLOSURE

7' x 14' x 8'

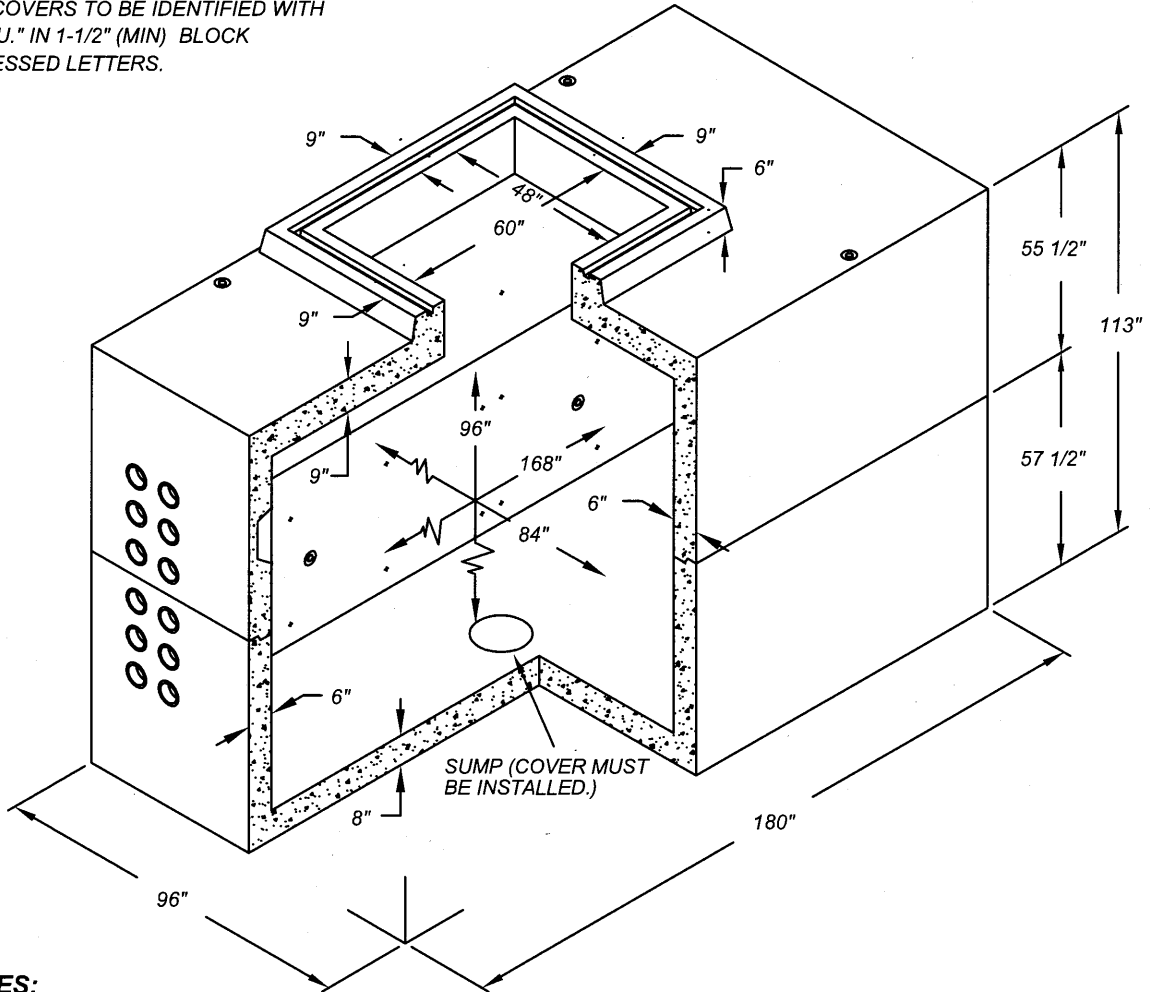

ALL COVERS TO BE IDENTIFIED WITH  
"M.V.U." IN 1-1/2" (MIN) BLOCK  
RECESSED LETTERS.



**NOTES:**

- 1.) VAULT DESIGNED IN ACCORDANCE WITH AASHTO H-20-44 TRAFFIC BRIDGE LOAD USING 5,500 PSI COMPRESSIVE STRENGTH CONCRETE AND 60,000 PSI YIELD STRENGTH ASTM 1-706 STEEL REINFORCEMENT.
- 2.) VAULT TO BE PLACED ON A MIN 6" BASE OF CRUSHER RUN FOR EASE OF INSTALLATION AND EVEN LOAD DISTRIBUTION.
- 3.) LIMIT OF COVER OVER ROOF SECTION IS 1'-6" TO 4'-0".
- 4.) LIMIT OF EMBEDMENT OF BOTTOM SECTION IS 10'-8" TO 13'-2".
- 5.) ALL WALLS AND CEILINGS TO BE PAINTED WITH WHITE PAINT.
- 6.) STEEL LADDER TO BE SUPPLIED WITH EACH VAULT.
- 7.) ADJUST TO GRADE WITH GRADE RINGS.
- 8.) ENCLOSURE TO BE INSTALLED WITH PRIMARY GROUND ASSEMBLY.
- 9.) ENCLOSURE TO BE INSTALLED WITH CABLE RACK ASSEMBLY.
- 10.) 13" DIA x 12" DIA SUMP x 4-1/2" DEEP WITH COVER, LOCATE AS FOLLOWS: BOTTOM OF SECTION (1) CORE MTD.
- 11.) PRIMARY GROUND TO BE #4 /O BC AND ATTACHED TO ALL GROUND INSERTS.

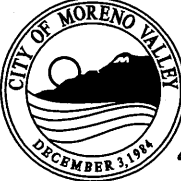
NOT TO SCALE

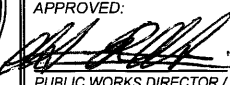
	RECOMMENDED:  12-27-16 DIVISION MANAGER DATE	<b>CITY OF MORENO VALLEY</b> PUBLIC WORKS DEPARTMENT - ELECTRIC UTILITY DIVISION	STANDARD PLAN
	APPROVED:  1/20/17 PUBLIC WORKS DIRECTOR / DATE CITY ENGINEER		VAULT <b>7' x 14' x 8'</b>



MORENO VALLEY STANDARD No MVEU-730B-0

PRECAST VAULT ENCLOSURE

7' x 18' x 8'

ALL COVERS TO BE IDENTIFIED WITH  
"M.V.U." IN 1-1/2" (MIN) BLOCK  
RECESSED LETTERS.

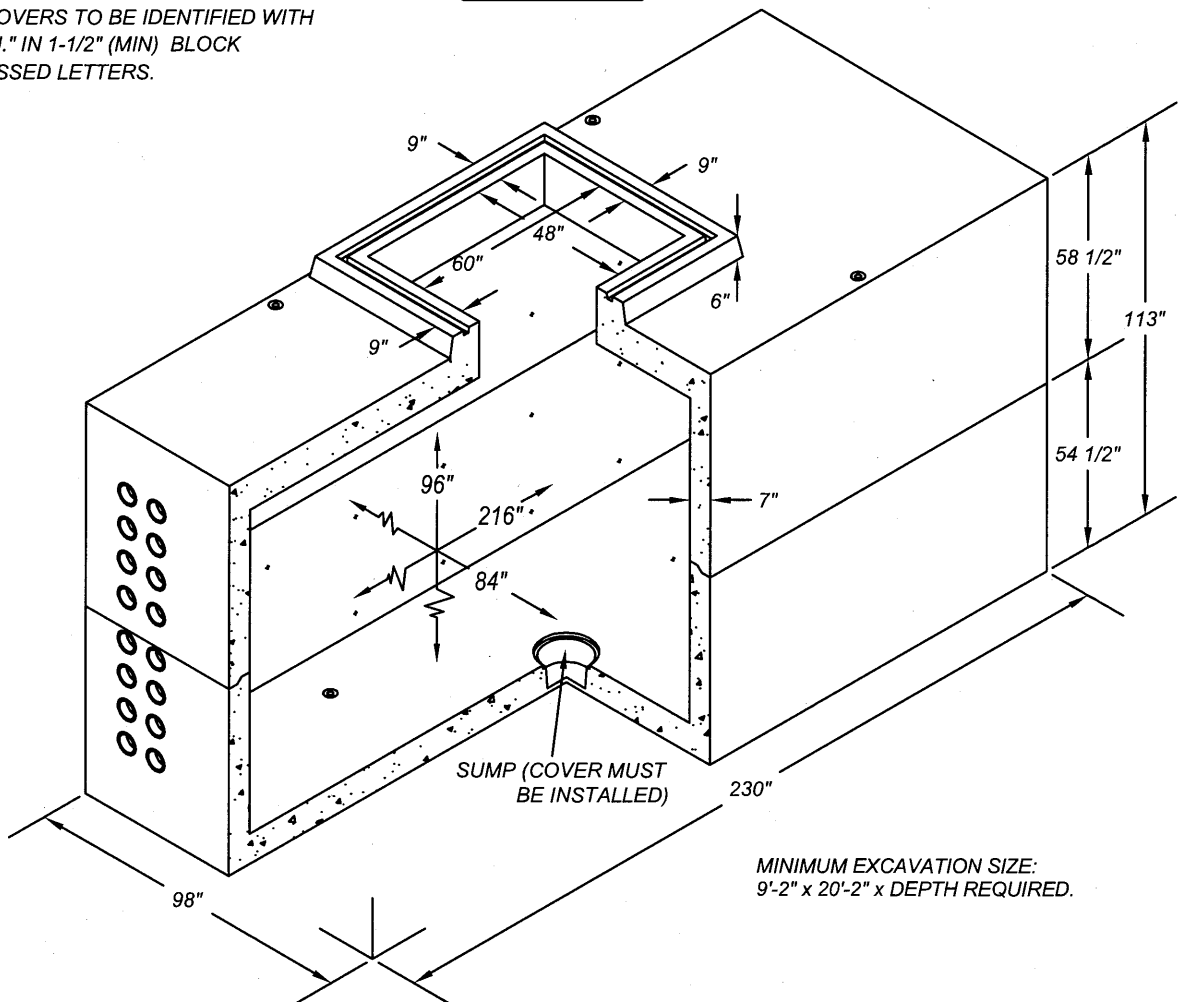

MINIMUM EXCAVATION SIZE:  
9'-2" x 20'-2" x DEPTH REQUIRED.

NOTES:

- 1.) VAULT DESIGNED IN ACCORDANCE WITH AASHTO H-20-44 TRAFFIC BRIDGE LOAD USING 5,500 PSI COMPRESSIVE STRENGTH CONCRETE AND 60,000 PSI YIELD STRENGTH ASTM 1-706 STEEL REINFORCEMENT.
- 2.) VAULT TO BE PLACED ON A MIN. 6" BASE OF CRUSHER RUN FOR EASE OF INSTALLATION AND EVEN LOAD DISTRIBUTION.
- 3.) LIMIT OF COVER OVER ROOF SECTION IS 1'-6" TO 4'-0".
- 4.) LIMIT OF EMBEDMENT OF BOTTOM SECTION IS 10'-8" TO 13'-2".
- 5.) ALL WALLS AND CEILINGS TO BE PAINTED WITH WHITE PAINT.
- 6.) STEEL LADDER TO BE SUPPLIED WITH EACH VAULT.
- 7.) ADJUST TO GRADE WITH GRADE RINGS.
- 8.) ENCLOSURE TO BE INSTALLED WITH PRIMARY GROUND ASSEMBLY.
- 9.) ENCLOSURE TO BE INSTALLED WITH CABLE RACK ASSEMBLY.
- 10.) 13" DIA x 14" DIA SUMP x 5" DEEP WITH RECESS, LOCATE AS FOLLOWS: BOTTOM OF SECTION (1) CORE MTD.
- 11.) PRIMARY GROUND TO BE #4 /O BC AND ATTACHED TO ALL GROUND INSERTS.

NOT TO SCALE

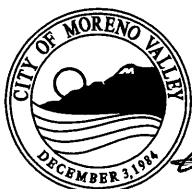

RECOMMENDED:

*[Signature]* 12-27-16  
DIVISION MANAGER DATE

APPROVED:

*[Signature]* 1/20/17  
PUBLIC WORKS DIRECTOR / DATE  
CITY ENGINEER

**CITY OF MORENO VALLEY**

PUBLIC WORKS DEPARTMENT - ELECTRIC UTILITY DIVISION

**VAULT  
7' x 18' x 8'**

STANDARD PLAN

**MVEU-730B-0**

SHEET 2 OF 3

**MORENO VALLEY STANDARD No MVEU-730C-0**

**4' x 6' PAD WITH 2.5' x 4' BOX FOR PMH-4 OR PMH-5 SWITCHGEAR**

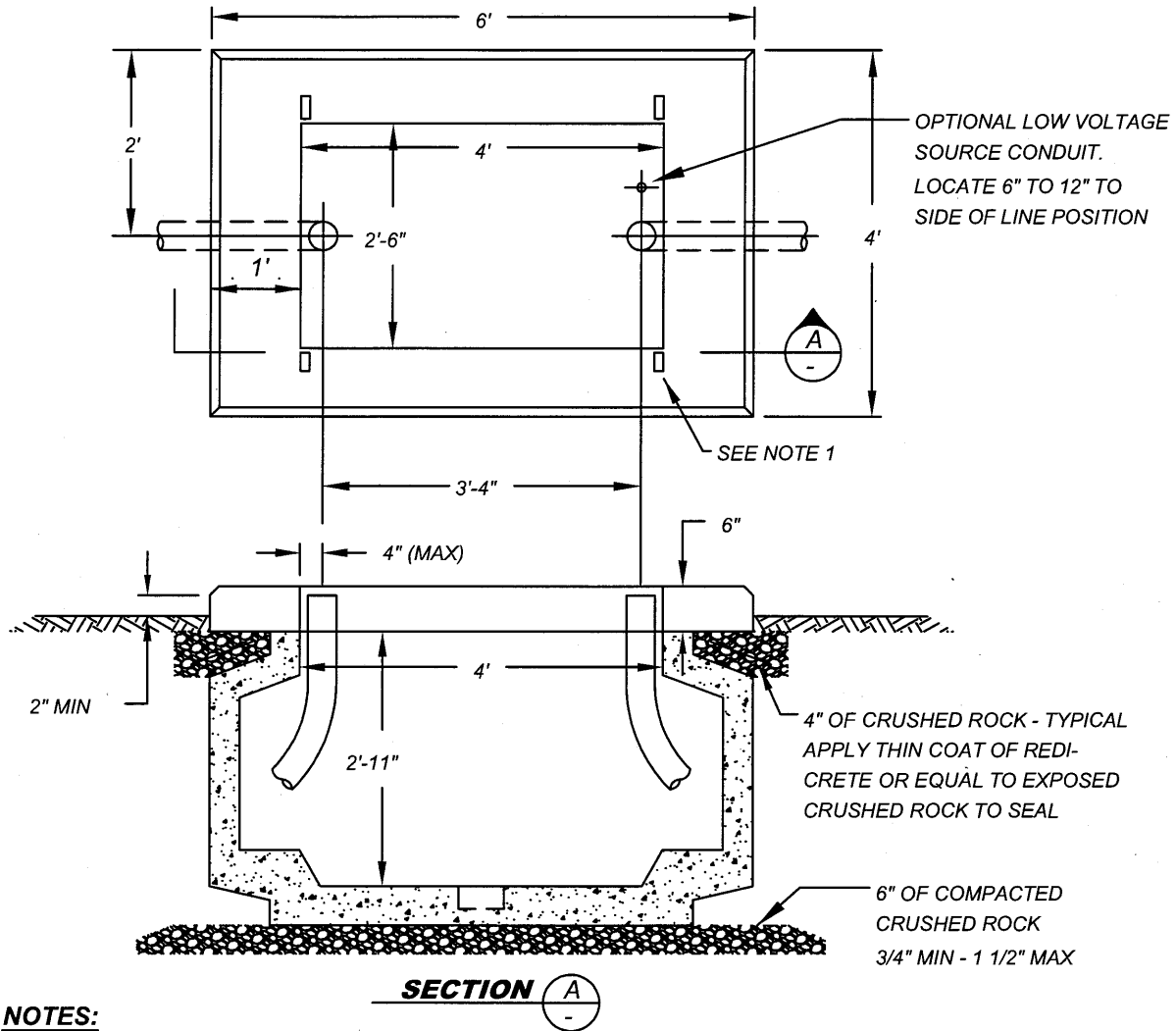

**NOTES:**

1. IDENTIFY BUS, OR FUSE POSITION ON DRAWING.
2. RISER BEND MUST TERMINATE VERTICALLY.
3. GALVANIZED UNISTRUT CHANNEL FOR SECURING SWITCH TO PAD.
4. SWITCHGEAR CAN ONLY BE INSTALLED WITH CABINET DOORS FACING ENDS. CABINET CAN BE ROTATED 180 DEGREES.
5. CABLE CLEAR OPENING SHALL BE COVERED WITH AN ELECTRICAL-APPROVED COVER AT THE TIME OF STRUCTURE PLACEMENT.
6. BACKFILL AROUND THE STRUCTURE SHALL BE WITH A MINIMUM OF ONE SACK PER YARD SAND CEMENT SLURRY TO WITHIN ONE FOOT OF FINISHED GRADE. THE SURFACE ELEVATION OF THE SLURRY SHALL NOT VARY MORE THAN ONE FOOT AROUND THE PERIMETER OF THE STRUCTURE AS IT IS BEING PLACED.
7. MINIMUM EXCAVATION PER MANUFACTURES RECOMMENDATIONS.
8. REFER TO STDS MVEU-722 & MVEU-723 FOR ADDITIONAL DETAILS.
9. ENCLOSURE TO BE INSTALLED WITH PRIMARY GROUND ASSEMBLY AND CABLE RACK ASSEMBLY.

NOT TO SCALE

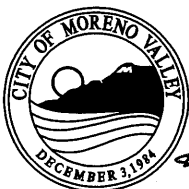

RECOMMENDED:  
 [Signature] 12-27-16  
 DIVISION MANAGER DATE  
 APPROVED:  
 [Signature] 1/20/17  
 PUBLIC WORKS DIRECTOR / DATE  
 CITY ENGINEER

**CITY OF MORENO VALLEY**

PUBLIC WORKS DEPARTMENT - ELECTRIC UTILITY DIVISION

**4' x 6' PAD WITH 2.5' x 4' BOX  
 FOR PMH-4 OR PMH-5  
 SWITCHGEAR**

STANDARD PLAN  
**MVEU-730C-0**  
 SHEET 3 OF 3

MORENO VALLEY STANDARD NO. MVEU-731-0

SUPPORT FOR CONDUITS ON BRIDGES

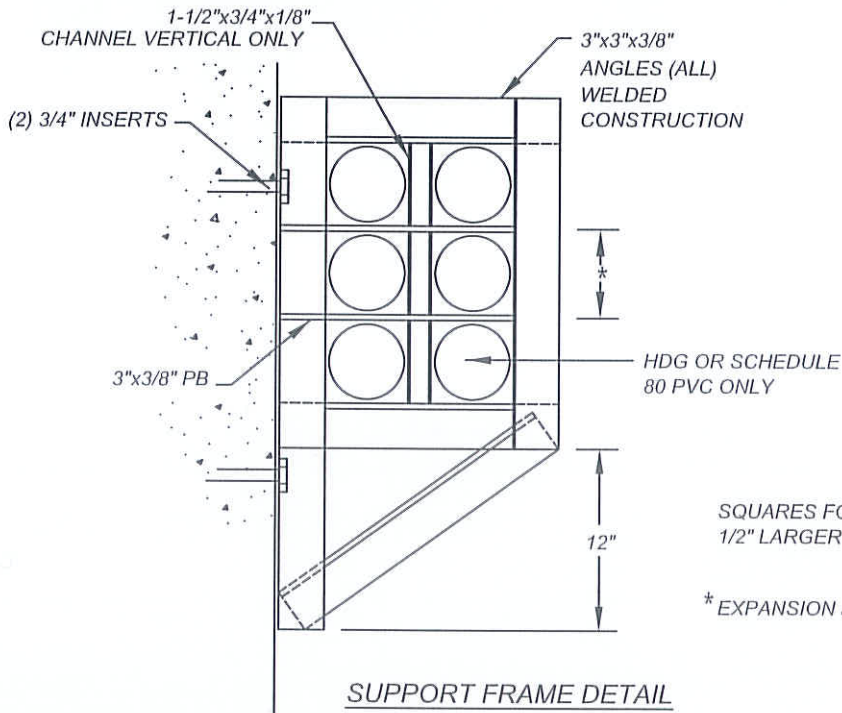
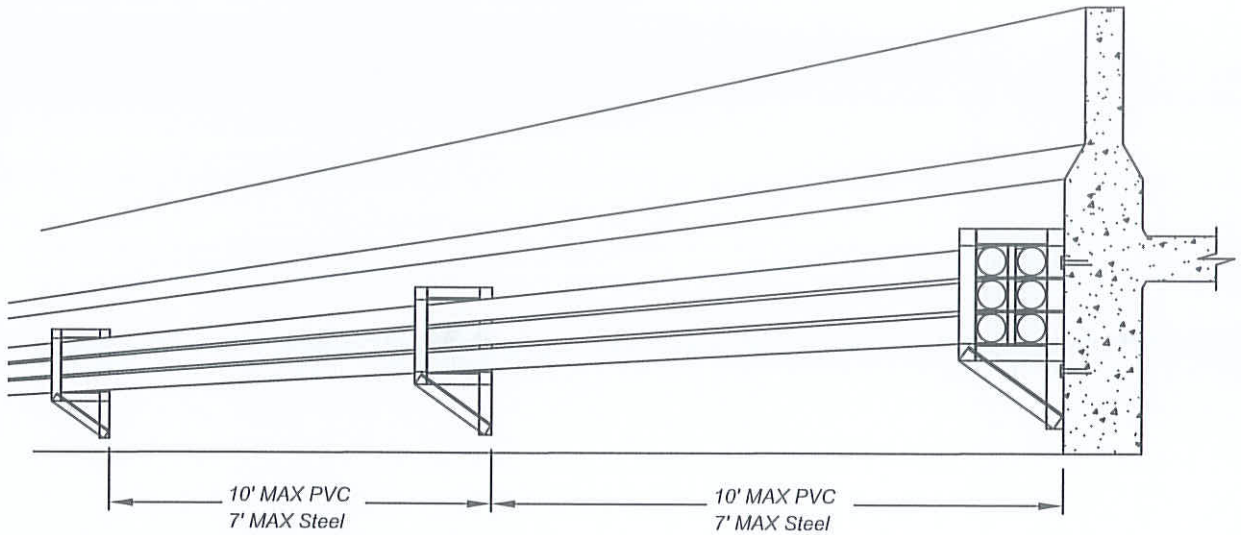

SUPPORT FRAME DETAIL

NOT TO SCALE

	RECOMMENDED: <i>[Signature]</i> 1-15-14 DIVISION MANAGER / DATE	<b>CITY OF MORENO VALLEY</b> PUBLIC WORKS DEPARTMENT - ELECTRIC UTILITY DIVISION	
	APPROVED: <i>[Signature]</i> 1/29/14 PUBLIC WORKS DIRECTOR / DATE CITY ENGINEER	<b>SUPPORT FOR CONDUITS ON BRIDGES</b>	

**MORENO VALLEY STANDARD NO. MVEU-732A-0**  
**SUPPORTS FOR CONDUITS ON BRIDGES**

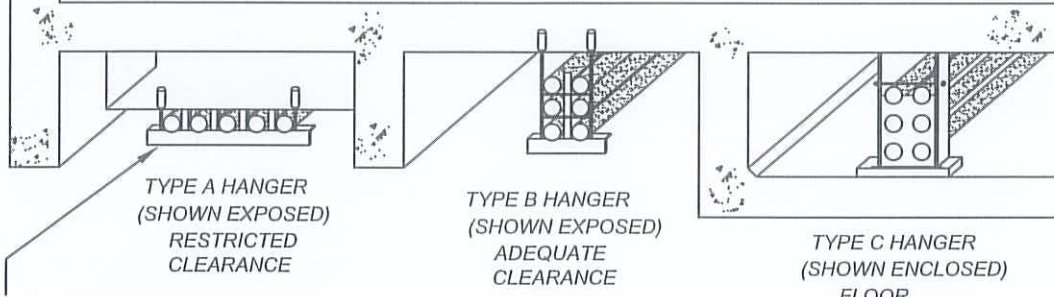

CONDUIT MAY BE SINGLE OR DOUBLE TIER (CENTER SUPPORT REQUIRED IF IN EXCESS OF 8 CONDUITS TOTAL)

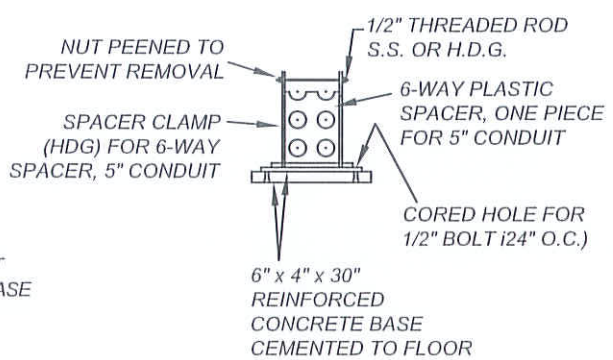
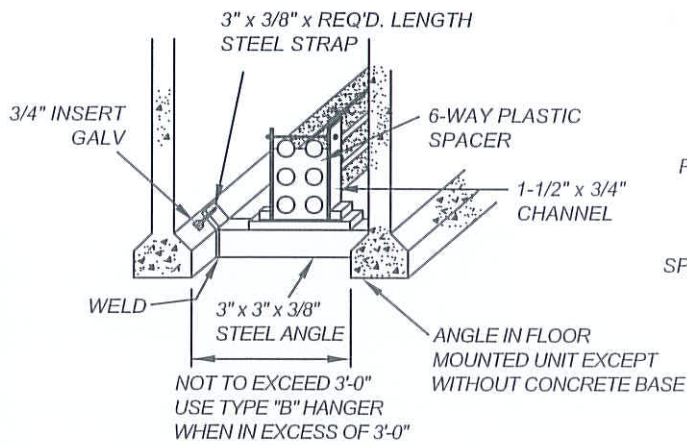
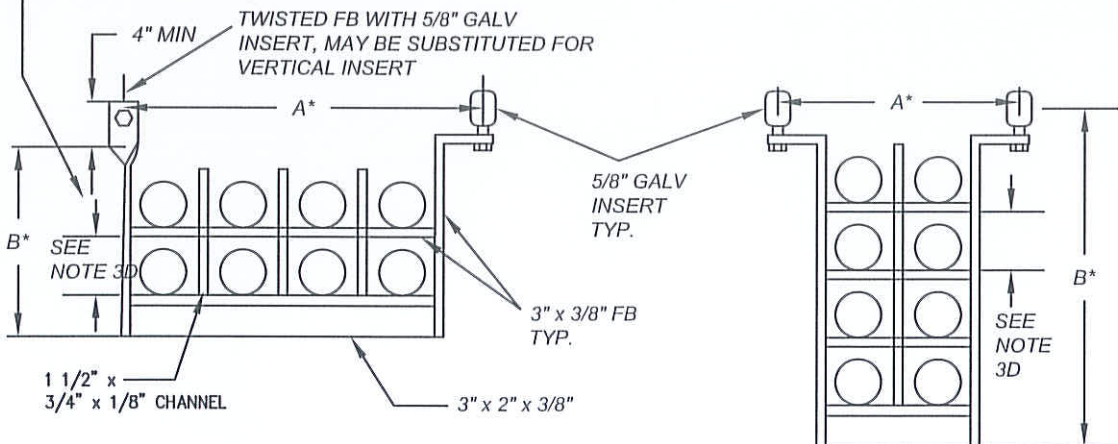

TYPE D HANGER  
 ALTERNATE TO HANGER SUPPORT (SHOWN EXPOSED)

NOT TO SCALE

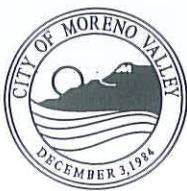
	RECOMMENDED: <i>[Signature]</i> 1-15-14 DIVISION MANAGER DATE	<b>CITY OF MORENO VALLEY</b> PUBLIC WORKS DEPARTMENT - ELECTRIC UTILITY DIVISION	STANDARD PLAN <b>MVEU-732A-0</b>
	APPROVED: <i>[Signature]</i> 1/29/14 PUBLIC WORKS DIRECTOR / DATE / CITY ENGINEER		<b>ALTERNATE SUPPORTS FOR CONDUITS ON BRIDGES</b>



MORENO VALLEY STANDARD NO. MVEU-732B-0  
SUPPORTS FOR CONDUITS ON BRIDGES

I. CONDUIT

- A. FOR EXPOSED INSTALLATIONS-SCHEDULE 80 PVC OR STANDARD HDG STEEL.
- B. FOR ENCLOSED INSTALLATIONS-PVC, OR HDG STEEL.
- C. CONDUIT CONFIGURATION TO BE SHOWN ON WORKING DRAWING.
- D. FOLLOWING ARE THE DIMENSIONS OF THE MINIMUM OPENING IN BRIDGE ABUTMENTS FOR CONDUIT BANK ENTRANCE AND EXIT. ALL FIGURES ARE BASED ON 5-INCH PLASTIC CONDUIT, VERTICAL CONFIGURATION, AND SPACED.
  - 4 CONDUIT BANK ..... 18" WIDE BY 18" HIGH
  - 6 CONDUIT BANK ..... 18" WIDE BY 26" HIGH
  - 8 CONDUIT BANK ..... 18" WIDE BY 33" HIGH
  - 10 CONDUIT BANK ..... 18" WIDE BY 41" HIGH

II. EXPANSION JOINTS

EXPANSION JOINT SHOULD BE INSTALLED AS FOLLOWS:

- 1. HDG STEEL-AT EACH BRIDGE EXPANSION JOINT.
- 2. PLASTIC-AT 200' MAXIMUM INTERVALS OR, IF BRIDGE IS SHORTER THAN 200',ONE JOINT.
- 3. CONDUIT TO BE ANCHORED AT EACH EXPANSION JOINT BY SOLVENT WELDING COLLARS ON CONDUIT AT EACH SIDE OF HANGER SUPPORT.

III. HANGER SUPPORT

- A. 10' MAXIMUM SPACING FOR SCHEDULE 80 PLASTIC CONDUIT.
- B. SUPPORTS TO BE HOT DIPPED GALVANIZED AFTER FABRICATION. (ALL BOLTS, STUDS, NUTS, ETC., TO BE STAINLESS STEEL.
- C. SUPPORTS SHOULD BE LOOSE ENOUGH TO ALLOW CONDUIT TO EXPAND AND CONTRACT WITH TEMPERATURE CHANGES.
- D. SQUARES THAT ENCLOSE CONDUIT IN SUPPORTS SHOULD BE APPROXIMATELY 1/2" LARGER THAN THE O.D. OF THE CONDUIT.

WEIGHTS FOR MATERIALS:	BOLTS:
SCH 80 PVC	1/2" Ø = 0.7 # FT
2.8 # FT	5/8" Ø = 1.1 # FT
3.9 # FT	3/4" Ø = 1.5 # FT
5.3 # FT	
3" x 3" x 3/8 STEEL ANGLE = 7.2 # FT	
1-1/2" x 3/4" STEEL CHANNEL = 2.5 # FT	
2' x 4" WOOD = 1.6 # FT	
CONCRETE BASE = 40 #	

NOT TO SCALE

	RECOMMENDED:  DIVISION MANAGER / DATE	<b>CITY OF MORENO VALLEY</b> PUBLIC WORKS DEPARTMENT - ELECTRIC UTILITY DIVISION	STANDARD PLAN <b>MVEU-732B-0</b>
	APPROVED:  PUBLIC WORKS DIRECTOR / CITY ENGINEER / DATE		<b>ALTERNATE SUPPORTS FOR CONDUITS ON BRIDGES</b>

MORENO VALLEY STANDARD NO. MVEU-733-0

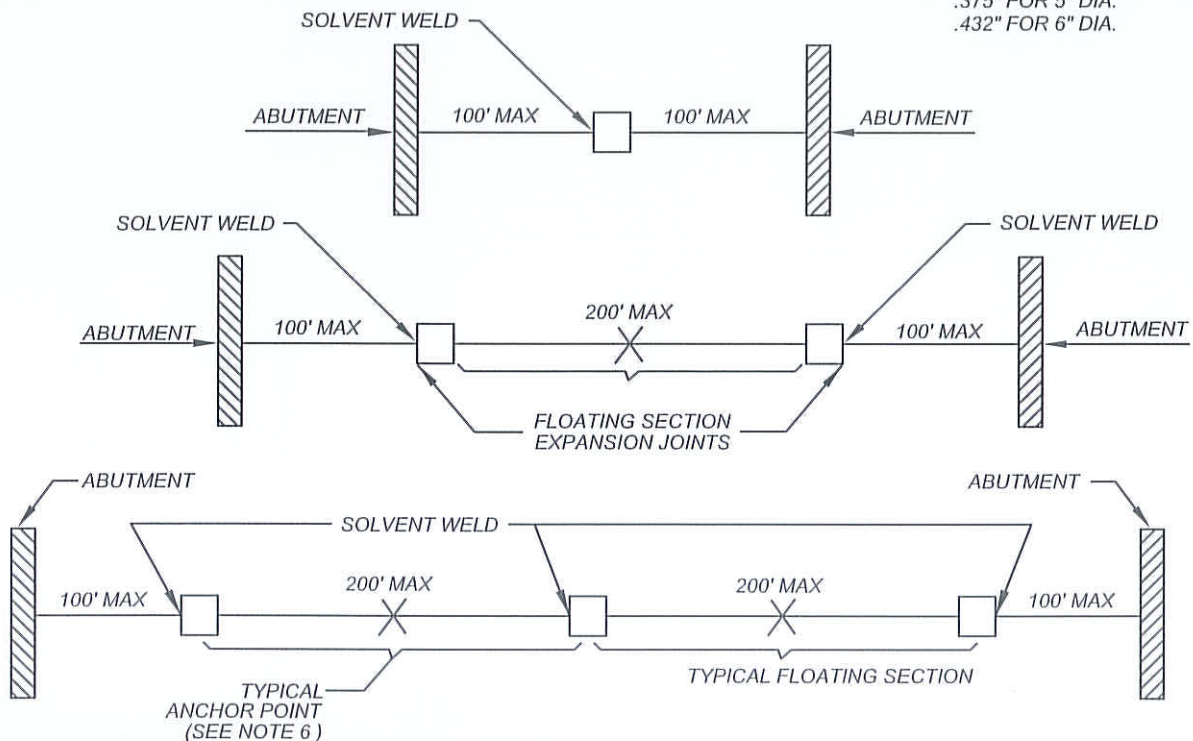
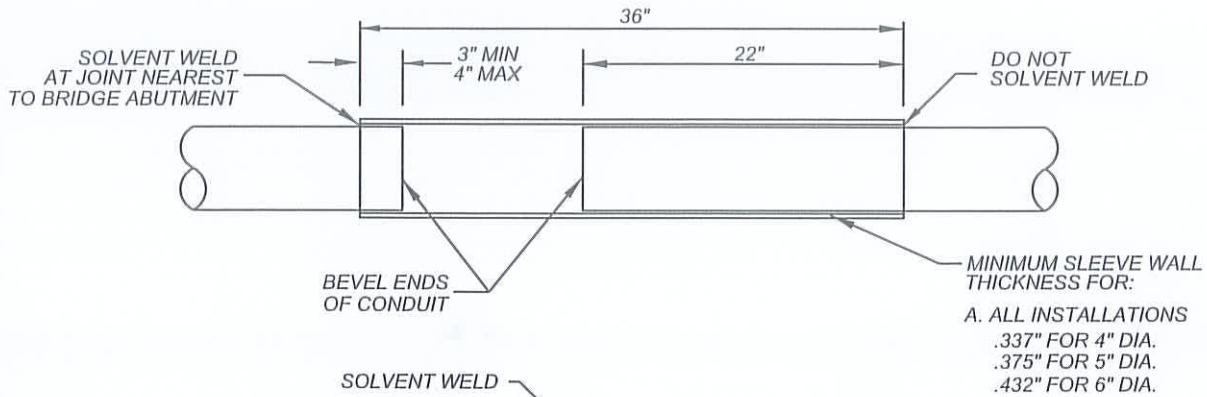

EXPANSION JOINT FOR PLASTIC CONDUIT



**NOTES:**

1. THE EXPANSION JOINT IS A LENGTH OF COUPLING STOCK EXTRUDED FROM THE SAME MATERIAL AS THE CONDUIT THAT IT JOINS.
2. THE MATING ENDS OF CONDUIT SHALL BE BEVELED TO PROVIDE A SMOOTH TRANSITION WITHIN THE JOINT.
3. THE EXPANSION JOINT SHALL BE SOLVENT WELDED 3 TO 4 INCHES ONTO ONE END OF THE CONDUIT.
4. THE MATING END OF THE CONDUIT SHALL THEN BE POSITIONED 22" INTO THE FREE END OF THE EXPANSION JOINT. DO NOT SOLVENT WELD.
5. INSTALL ALL EXPANSION JOINTS AT THE MIDWAY POINT BETWEEN CONDUIT SUPPORTS SO THE MAXIMUM DISTANCE CAN BE MAINTAINED FROM ALL SPACERS, SUPPORTS, OR STRAPS.
6. INSTALL THE EXPANSION JOINT WITHIN 100' OF THE BRIDGE ABUTMENT. WHEN ONLY ONE EXPANSION JOINT IS REQUIRED, DO NOT ANCHOR THE EXPANSION JOINT OR CONDUIT. WHEN TWO OR MORE EXPANSION JOINTS ARE REQUIRED, EACH SECTION OF FLOATING CONDUIT MUST BE ANCHORED AT MID-POINT BETWEEN THE EXPANSION JOINTS TO PREVENT EXCESSIVE LONGITUDINAL MOVEMENT. CONDUIT TO BE ANCHORED BY SOLVENT WELDING COLLARS AT EACH SIDE OF HANGER SUPPORT.

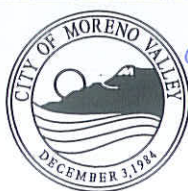
NOT TO SCALE

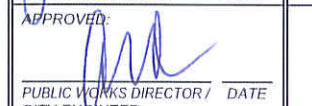
	RECOMMENDED:  DIVISION MANAGER      DATE	<h2 style="margin: 0;">CITY OF MORENO VALLEY</h2> <p style="margin: 0;">- PUBLIC WORKS DEPARTMENT - ELECTRIC UTILITY DIVISION -</p>	STANDARD PLAN <h3 style="margin: 0;">MVEU-733-0</h3>
	APPROVED:  PUBLIC WORKS DIRECTOR / DATE CITY ENGINEER	<h3 style="margin: 0;">EXPANSION JOINT FOR PLASTIC CONDUIT</h3>	SHEET 1 OF 1